

General-Purpose AC Servo

MITSUBISHI SERVO AMPLIFIERS & MOTORS
MELSERV/o-JE

**SSCNETIII/H Interface AC Servo
SERVO AMPLIFIER INSTRUCTION MANUAL**

-MR-JE-_B

● Safety instructions ●

Please read the instructions carefully before using the equipment.

To use the equipment correctly, do not attempt to install, operate, maintain, or inspect the equipment until you have read through this Instruction Manual, Installation guide, and appended documents carefully. Do not use the equipment until you have a full knowledge of the equipment, safety information and instructions. In this Instruction Manual, the safety instruction levels are classified into "WARNING" and "CAUTION".



Indicates that incorrect handling may cause hazardous conditions, resulting in death or severe injury.



Indicates that incorrect handling may cause hazardous conditions, resulting in medium or slight injury to personnel or may cause physical damage.

Note that the  CAUTION level may lead to a serious consequence according to conditions.

Please follow the instructions of both levels because they are important to personnel safety.

What must not be done and what must be done are indicated by the following diagrammatic symbols.



Indicates what must not be done. For example, "No Fire" is indicated by .



Indicates what must be done. For example, grounding is indicated by .

In this Instruction Manual, instructions at a lower level than the above, instructions for other functions, and so on are classified into "POINT".

After reading this Instruction Manual, keep it accessible to the operator.

1. To prevent electric shock, note the following.

WARNING

- Before wiring and inspections, turn off the power and wait for 15 minutes or more until the charge lamp turns off. Otherwise, an electric shock may occur. In addition, when confirming whether the charge lamp is off or not, always confirm it from the front of the servo amplifier.
- Ground the servo amplifier and servo motor securely.
- Any person who is involved in wiring and inspection should be fully competent to do the work.
- Do not attempt to wire the servo amplifier and servo motor until they have been installed. Otherwise, it may cause an electric shock.
- Do not operate switches with wet hands. Otherwise, it may cause an electric shock.
- The cables should not be damaged, stressed, loaded, or pinched. Otherwise, it may cause an electric shock.
- To prevent an electric shock, always connect the protective earth (PE) terminal (marked \oplus) of the servo amplifier to the protective earth (PE) of the cabinet.
- To avoid an electric shock, insulate the connections of the power supply terminals.

2. To prevent fire, note the following.

CAUTION

- Install the servo amplifier, servo motor, and regenerative resistor on incombustible material. Installing them directly or close to combustibles will lead to smoke or a fire.
- Always connect a magnetic contactor between the power supply and the power supply (L1/L2/L3) of the servo amplifier, in order to configure a circuit that shuts down the power supply on the side of the servo amplifier's power supply. If a magnetic contactor is not connected, continuous flow of a large current may cause smoke or a fire when the servo amplifier malfunctions.
- Always connect a molded-case circuit breaker, or a fuse to each servo amplifier between the power supply and the power supply (L1/L2/L3) of the servo amplifier, in order to configure a circuit that shuts down the power supply on the side of the servo amplifier's power supply. If a molded-case circuit breaker or fuse is not connected, continuous flow of a large current may cause smoke or a fire when the servo amplifier malfunctions.
- When using the regenerative resistor, switch power off with the alarm signal. Otherwise, a regenerative transistor malfunction or the like may overheat the regenerative resistor, causing smoke or a fire.
- When you use a regenerative option with an MR-JE-40B to MR-JE-100B, remove the built-in regenerative resistor and wiring from the servo amplifier.
- Provide adequate protection to prevent screws and other conductive matter, oil and other combustible matter from entering the servo amplifier and servo motor.

3. To prevent injury, note the following.

CAUTION

- Only the power/signal specified in the Instruction Manual must be supplied/applied to each terminal. Otherwise, an electric shock, fire, injury, etc. may occur.
- Connect cables to the correct terminals. Otherwise, a burst, damage, etc. may occur.
- Ensure that polarity (+/-) is correct. Otherwise, a burst, damage, etc. may occur.
- The servo amplifier heat sink, regenerative resistor, servo motor, etc., may be hot while the power is on and for some time after power-off. Take safety measures such as providing covers to avoid accidentally touching them by hands and parts such as cables.

4. Additional instructions

The following instructions should also be fully noted. Incorrect handling may cause a malfunction, injury, electric shock, fire, etc.

(1) Transportation and installation

CAUTION

- Transport the products correctly according to their mass.
- Stacking in excess of the specified number of product packages is not allowed.
- Do not hold the lead of the built-in regenerative resistor, cables, or connectors when carrying the servo amplifier. Otherwise, it may drop.
- Install the servo amplifier and the servo motor in a load-bearing place in accordance with the Instruction Manual.
- Do not get on or put heavy load on the equipment. Otherwise, it may cause injury.
- The equipment must be installed in the specified direction.
- Leave specified clearances between the servo amplifier and the cabinet walls or other equipment.
- Do not install or operate the servo amplifier and servo motor which have been damaged or have any parts missing.
- Do not block the intake and exhaust areas of the servo amplifier. Otherwise, it may cause a malfunction.
- Do not drop or apply heavy impact on the servo amplifiers and the servo motors. Otherwise, injury, malfunction, etc. may occur.
- Do not strike the connector. Otherwise, a connection failure, malfunction, etc. may occur.
- When you keep or use the equipment, please fulfill the following environment.

Item		Environment
Ambient temperature	Operation	0 °C to 55 °C (non-freezing)
	Storage	-20 °C to 65 °C (non-freezing)
Ambient humidity	Operation	5 %RH to 90 %RH (non-condensing)
	Storage	
Ambience		Indoors (no direct sunlight), free from corrosive gas, flammable gas, oil mist, dust, and dirt
Altitude		2000 m or less above sea level (Contact your local sales office for the altitude for options.)
Vibration resistance		5.9 m/s ² , at 10 Hz to 55 Hz (directions of X, Y and Z axes)

- When the product has been stored for an extended period of time, contact your local sales office.
- When handling the servo amplifier, be careful about the edged parts such as corners of the servo amplifier.
- The servo amplifier must be installed in a metal cabinet.
- When fumigants that contain halogen materials such as fluorine, chlorine, bromine, and iodine are used for disinfecting and protecting wooden packaging from insects, they cause malfunction when entering our products. Please take necessary precautions to ensure that remaining materials from fumigant do not enter our products, or treat packaging with methods other than fumigation (heat method). Additionally, disinfect and protect wood from insects before packing products.
- To prevent a fire or injury from occurring in case of an earthquake or other natural disasters, securely install, mount, and wire the servo motor in accordance with the Instruction Manual.

(2) Wiring

⚠ CAUTION

- Before removing the CNP1 connector of MR-JE-40B to MR-JE-100B, disconnect the lead wires of the regenerative resistor from the CNP1 connector.
- Wire the equipment correctly and securely. Otherwise, the servo motor may operate unexpectedly.
- Make sure to connect the cables and connectors by using the fixing screws and the locking mechanism. Otherwise, the cables and connectors may be disconnected during operation.
- Do not install a power capacitor, surge killer, or radio noise filter (optional FR-BIF) on the servo amplifier output side.
- To avoid a malfunction, connect the wires to the correct phase terminals (U/V/W) of the servo amplifier and servo motor.
- Connect the servo amplifier power output (U/V/W) to the servo motor power input (U/V/W) directly. Do not let a magnetic contactor, etc. intervene. Otherwise, it may cause a malfunction.

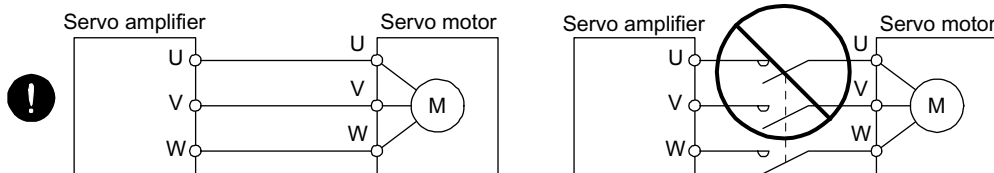

- The connection diagrams in this instruction manual are shown for sink interfaces, unless stated otherwise.
- The surge absorbing diode installed to the DC relay for control output should be fitted in the specified direction. Otherwise, the emergency stop and other protective circuits may not operate.

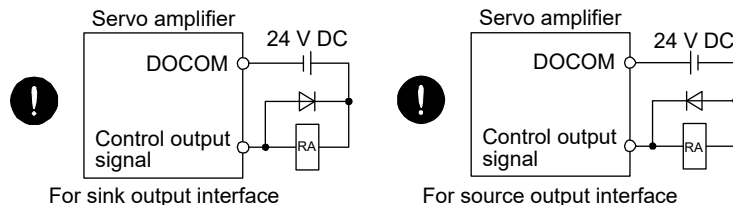

- When the cable is not tightened enough to the terminal block, the cable or terminal block may generate heat because of the poor contact. Be sure to tighten the cable with specified torque.
- Connecting a servo motor of the wrong axis to U, V, W, or CN2 of the servo amplifier may cause a malfunction.
- Configure a circuit to turn off EM2 or EM1 when the power supply is turned off to prevent an unexpected restart of the servo amplifier.
- To prevent malfunction, avoid bundling power lines (input/output) and signal cables together or running them in parallel to each other. Separate the power lines from the signal cables.

(3) Test run and adjustment

⚠ CAUTION

- When executing a test run, follow the notice and procedures in this instruction manual. Otherwise, it may cause a malfunction, damage to the machine, or injury.
- Before operation, check the parameter settings. Improper settings may cause some machines to operate unexpectedly.

CAUTION

- Never adjust or change the parameter values extremely as it will make operation unstable.
- Do not get close to moving parts during the servo-on status.

(4) Usage

CAUTION

- When it is assumed that a hazardous condition may occur due to a power failure or product malfunction, use a servo motor with an external brake to prevent the condition.
- For equipment in which the moving part of the machine may collide against the load side, install a limit switch or stopper to the end of the moving part. The machine may be damaged due to a collision.
- Do not disassemble, repair, or modify the product. Otherwise, an electric shock, fire, injury, etc. may occur. Disassembled, repaired, and/or modified products are not covered under warranty.
- Before resetting an alarm, make sure that the run signal of the servo amplifier is off in order to prevent a sudden restart. Otherwise, it may cause an accident.
- Use a noise filter, etc. to minimize the influence of electromagnetic interference. Electromagnetic interference may be given to the electronic equipment used near the servo amplifier.
- Burning or breaking a servo amplifier may cause a toxic gas. Do not burn or break it.
- Use the servo amplifier with the specified servo motor.
- Correctly wire options and peripheral equipment, etc. in the correct combination. Otherwise, an electric shock, fire, injury, etc. may occur.
- The electromagnetic brake on the servo motor is designed to hold the motor shaft and should not be used for ordinary braking.
- For such reasons as incorrect wiring, service life, and mechanical structure (e.g. where a ball screw and the servo motor are coupled via a timing belt), the electromagnetic brake may not hold the motor shaft. To ensure safety, install a stopper on the machine side.
- If the dynamic brake is activated at power-off, alarm occurrence, etc., do not rotate the servo motor by an external force. Otherwise, it may cause a fire.

(5) Corrective actions

CAUTION

- Ensure safety by confirming the power off, etc. before performing corrective actions. Otherwise, it may cause an accident.
- If it is assumed that a power failure, machine stoppage, or product malfunction may result in a hazardous situation, use a servo motor with an electromagnetic brake or provide an external brake system for holding purpose to prevent such hazard.
- When any alarm has occurred, eliminate its cause, ensure safety, and deactivate the alarm before restarting operation.
- If the molded-case circuit breaker or fuse is activated, be sure to remove the cause and secure safety before switching the power on. If necessary, replace the servo amplifier and recheck the wiring. Otherwise, it may cause smoke, fire, or an electric shock.
- Provide an adequate protection to prevent unexpected restart after an instantaneous power failure.

⚠ CAUTION

- Configure an electromagnetic brake circuit which is interlocked with an external emergency stop switch.

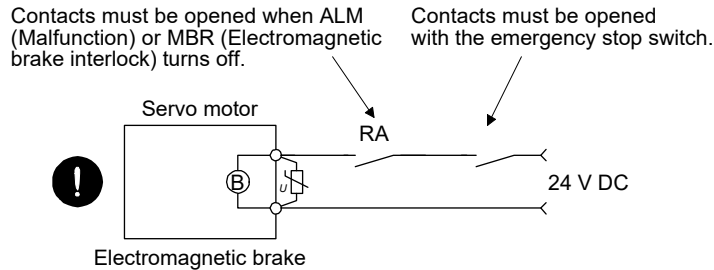

- A failure of MBR (Electromagnetic brake interlock) or ALM (Malfunction) leads to the malfunction of a brake.
- To prevent an electric shock, injury, or fire from occurring after an earthquake or other natural disasters, ensure safety by checking conditions, such as the installation, mounting, wiring, and equipment before switching the power on.

(6) Maintenance, inspection and parts replacement

⚠ CAUTION

- Make sure that the emergency stop circuit operates properly such that an operation can be stopped immediately and a power is shut off by the emergency stop switch.
- It is recommended that the servo amplifier be replaced every 10 years when it is used in general environment.
- When using a servo amplifier whose power has not been turned on for a long time, contact your local sales office.

(7) General instruction

- To illustrate details, the equipment in the diagrams of this Instruction Manual may have been drawn without covers and safety guards. When the equipment is operated, the covers and safety guards must be installed as specified. Operation must be performed in accordance with this Instruction Manual.

EEPROM life

The number of write times to the EEPROM, which stores parameter settings, etc., is limited to 100,000. If the total number of the following operations exceeds 100,000, the servo amplifier may malfunction when the EEPROM reaches the end of its useful life.

- Write to the EEPROM due to parameter setting changes
- Write to the EEPROM due to device changes

Compliance with global standards

Refer to app. 4 for the compliance with global standards.

«About the manual»

You must have this Instruction Manual and the following manuals to use this servo. Ensure to prepare them to use the servo safely.

Relevant manuals

Manual name	Manual No.
MELSERVO-JE Servo Amplifier Instruction Manual (Troubleshooting)	SH(NA)030166ENG
MELSERVO HG-KN_/HG-SN_ Servo Motor Instruction Manual	SH(NA)030135ENG
MELSERVO EMC Installation Guidelines	IB(NA)67310ENG

«Cables used for wiring»

Wires mentioned in this Instruction Manual are selected based on the ambient temperature of 40 °C.

«U.S. customary units»

U.S. customary units are not shown in this manual. Convert the values if necessary according to the following table.

Quantity	SI (metric) unit	U.S. customary unit
Mass	1 [kg]	2.2046 [lb]
Length	1 [mm]	0.03937 [inch]
Torque	1 [N·m]	141.6 [oz·inch]
Moment of inertia	1 [(× 10 ⁻⁴ kg·m ²)]	5.4675 [oz·inch ²]
Load (thrust load/axial load)	1 [N]	0.2248 [lbf]
Temperature	N [°C] × 9/5 + 32	N [°F]

Global standards and regulations

Compliance with the indicated global standards and regulations is current as of the release date of this manual. Some standards and regulations may have been modified or withdrawn.

CONTENTS

1. FUNCTIONS AND CONFIGURATION	1- 1 to 1-12
1.1 Summary.....	1- 1
1.2 Function block diagram.....	1- 2
1.3 Servo amplifier standard specifications	1- 4
1.4 Combinations of servo amplifiers, servo motors, and controllers.....	1- 5
1.4.1 Combinations of servo amplifiers and servo motors.....	1- 5
1.4.2 Compatible controller	1- 5
1.5 Function list.....	1- 6
1.6 Model designation.....	1- 8
1.7 Structure	1- 9
1.7.1 Parts identification.....	1- 9
1.8 Configuration including peripheral equipment	1-11
2. INSTALLATION	2- 1 to 2- 8
2.1 Installation direction and clearances	2- 2
2.2 Keep out foreign materials.....	2- 3
2.3 Encoder cable stress	2- 4
2.4 SSCNET III cable laying	2- 4
2.5 Inspection items.....	2- 6
2.6 Parts having service life.....	2- 7
2.7 Restrictions when using this product at altitude exceeding 1000 m and up to 2000 m above sea level.....	2- 8
3. SIGNALS AND WIRING	3- 1 to 3-44
3.1 Input power supply circuit	3- 2
3.2 I/O signal connection example.....	3-11
3.2.1 For sink I/O interface.....	3-11
3.2.2 For source I/O interface	3-13
3.3 Explanation of power supply system	3-14
3.3.1 Signal explanations	3-14
3.3.2 Power-on sequence	3-15
3.3.3 Wiring CNP1 and CNP2.....	3-16
3.4 Connectors and pin assignment.....	3-18
3.5 Signal (device) explanations.....	3-19
3.5.1 Input device	3-19
3.5.2 Output device	3-20
3.5.3 Power supply.....	3-21
3.6 Forced stop deceleration function	3-22
3.6.1 Forced stop deceleration function.....	3-22
3.6.2 Base circuit shut-off delay time function	3-23
3.6.3 Vertical axis freefall prevention function	3-24
3.6.4 Residual risks of the forced stop function (EM2)	3-24
3.7 Alarm occurrence timing chart.....	3-25
3.7.1 When you use the forced stop deceleration function.....	3-25
3.7.2 When you do not use the forced stop deceleration function.....	3-26
3.7.3 Hot line forced stop function.....	3-27

3.8 Interfaces	3-33
3.8.1 Internal connection diagram.....	3-33
3.8.2 Detailed explanation of interfaces.....	3-34
3.8.3 Source I/O interfaces	3-35
3.9 SSCNET III cable connection	3-36
3.10 Servo motor with an electromagnetic brake	3-38
3.10.1 Safety precautions	3-38
3.10.2 Timing chart	3-40
3.11 Grounding	3-43

4. STARTUP	4- 1 to 4-16
-------------------	---------------------

4.1 Switching power on for the first time.....	4- 2
4.1.1 Startup procedure	4- 2
4.1.2 Wiring check.....	4- 3
4.1.3 Surrounding environment.....	4- 4
4.2 Startup	4- 5
4.3 Switch setting and display of the servo amplifier.....	4- 6
4.3.1 Axis selection rotary switch (SW1).....	4- 6
4.3.2 Scrolling display	4- 8
4.3.3 Status display of an axis	4- 9
4.4 Test operation	4-11
4.5 Test operation mode.....	4-11
4.5.1 Test operation mode in MR Configurator2.....	4-12
4.5.2 Motor-less operation in the controller.....	4-14

5. PARAMETERS	5- 1 to 5-42
----------------------	---------------------

5.1 Parameter list.....	5- 1
5.1.1 Basic setting parameters ([Pr. PA_ _]).....	5- 2
5.1.2 Gain/filter setting parameters ([Pr. PB_ _]).....	5- 3
5.1.3 Extension setting parameters ([Pr. PC_ _])	5- 4
5.1.4 I/O setting parameters ([Pr. PD_ _])	5- 6
5.1.5 Extension setting 2 parameters ([Pr. PE_ _]).....	5- 7
5.1.6 Extension setting 3 parameters ([Pr. PF_ _]).....	5- 8
5.2 Detailed list of parameters	5-10
5.2.1 Basic setting parameters ([Pr. PA_ _]).....	5-10
5.2.2 Gain/filter setting parameters ([Pr. PB_ _]).....	5-18
5.2.3 Extension setting parameters ([Pr. PC_ _])	5-31
5.2.4 I/O setting parameters ([Pr. PD_ _])	5-34
5.2.5 Extension setting 2 parameters ([Pr. PE_ _]).....	5-39
5.2.6 Extension setting 3 parameters ([Pr. PF_ _]).....	5-40

6. NORMAL GAIN ADJUSTMENT	6- 1 to 6-28
----------------------------------	---------------------

6.1 Different adjustment methods.....	6- 1
6.1.1 Adjustment on a single servo amplifier	6- 1
6.1.2 Adjustment using MR Configurator2	6- 2
6.2 One-touch tuning	6- 3
6.2.1 One-touch tuning flowchart.....	6- 5
6.2.2 Display transition and operation procedure of one-touch tuning	6- 7

6.2.3 Caution for one-touch tuning	6-18
6.3 Auto tuning	6-19
6.3.1 Auto tuning mode	6-19
6.3.2 Auto tuning mode basis	6-20
6.3.3 Adjustment procedure by auto tuning	6-21
6.3.4 Response level setting in auto tuning mode	6-22
6.4 Manual mode	6-23
6.5 2 gain adjustment mode	6-26

7. SPECIAL ADJUSTMENT FUNCTIONS	7- 1 to 7-30
--	---------------------

7.1 Filter setting	7- 1
7.1.1 Machine resonance suppression filter	7- 1
7.1.2 Adaptive filter II	7- 4
7.1.3 Shaft resonance suppression filter	7- 6
7.1.4 Low-pass filter	7- 7
7.1.5 Advanced vibration suppression control II	7- 7
7.1.6 Command notch filter	7-11
7.2 Gain switching function	7-13
7.2.1 Applications	7-13
7.2.2 Function block diagram	7-14
7.2.3 Parameter	7-15
7.2.4 Gain switching procedure	7-18
7.3 Tough drive function	7-22
7.3.1 Vibration tough drive function	7-22
7.3.2 Instantaneous power failure tough drive function	7-24
7.4 Model adaptive control disabled	7-26
7.5 Lost motion compensation function	7-27

8. TROUBLESHOOTING	8- 1 to 8- 8
---------------------------	---------------------

8.1 Explanation for the lists	8- 1
8.2 Alarm list	8- 2
8.3 Warning list	8- 6

9. DIMENSIONS	9- 1 to 9- 4
----------------------	---------------------

9.1 Servo amplifier	9- 1
9.2 Connector	9- 4

10. CHARACTERISTICS	10- 1 to 10- 8
----------------------------	-----------------------

10.1 Overload protection characteristics	10- 1
10.2 Power supply capacity and generated loss	10- 3
10.3 Dynamic brake characteristics	10- 5
10.3.1 Dynamic brake operation	10- 6
10.3.2 Permissible load to motor inertia when the dynamic brake is used	10- 7
10.4 Cable bending life	10- 7
10.5 Inrush current at power-on	10- 8

11. OPTIONS AND PERIPHERAL EQUIPMENT

11- 1 to 11-47

11.1	Cable/connector sets	11- 1
11.1.1	Combinations of cable/connector sets	11- 2
11.1.2	SSCNET III cable	11- 5
11.1.3	Battery cable and junction battery cable	11- 7
11.2	Regenerative option.....	11- 8
11.2.1	Combination and regenerative power	11- 8
11.2.2	Selection of regenerative option	11- 9
11.2.3	Parameter setting	11-10
11.2.4	Connection of regenerative option	11-11
11.2.5	Dimensions	11-15
11.3	Junction terminal block PS7DW-20V14B-F (recommended)	11-17
11.4	MR Configurator2	11-18
11.4.1	Engineering software	11-18
11.4.2	Precautions for using USB communication function.....	11-19
11.5	Battery	11-20
11.5.1	Selection of battery	11-20
11.5.2	MR-BAT6V1SET-A battery	11-21
11.5.3	MR-BT6VCASE battery case	11-25
11.5.4	MR-BAT6V1 battery	11-31
11.6	Selection example of wires	11-32
11.7	Molded-case circuit breakers, fuses, magnetic contactors	11-33
11.8	Power factor improving AC reactor.....	11-34
11.9	Relay (recommended)	11-35
11.10	Noise reduction techniques	11-36
11.11	Earth-leakage current breaker	11-42
11.12	EMC filter (recommended)	11-44

12. ABSOLUTE POSITION DETECTION SYSTEM

12- 1 to 12- 4

12.1	Summary.....	12- 1
12.1.1	Features	12- 1
12.1.2	Configuration.....	12- 2
12.1.3	Parameter setting.....	12- 2
12.1.4	Confirmation of absolute position detection data	12- 2
12.2	Battery	12- 3
12.2.1	Using the MR-BAT6V1SET-A battery	12- 3
12.2.2	Using the MR-BT6VCASE battery case.....	12- 4

APPENDIX

App. - 1 to App. -14

App. 1	Peripheral equipment manufacturer (for reference).....	App.- 1
App. 2	Handling of AC servo amplifier batteries for the United Nations Recommendations on the Transport of Dangerous Goods	App.- 1
App. 3	Symbol for the new EU Battery Directive	App.- 4
App. 4	Compliance with global standards	App.- 5
App. 5	SSCNET III cable (SC-J3BUS_M-C) manufactured by Mitsubishi Electric System & Service	App.-5
App. 6	Low-voltage directive	App.-6
App. 7	When turning on or off the input power supply with DC power supply	App.-7

App. 8	When using the hot line forced stop function in combination with MR-J4-_B servo amplifier and MR-J4W-_B servo amplifier	App.-8
App. 9	Optional data monitor function	App.-9
App. 10	Using the neutral point of a 3-phase 400 V AC class power supply for inputting a 1-phase 200 V AC class power supply	App.-10
App. 11	Status of general-purpose AC servo products for compliance with the China RoHS directive	App.- 12
App. 12	Error excessive alarm level adjustment method	App.- 14

1. FUNCTIONS AND CONFIGURATION

1. FUNCTIONS AND CONFIGURATION

1.1 Summary

POINT
<ul style="list-style-type: none">● Refer to section 1.4.2 for compatible controllers.● The MR-JE-_B servo amplifier is connectable only through SSCNETIII/H. Do not connect the servo amplifier through SSCNETIII. When the servo amplifier is connected through SSCNETIII, reset the mode to the factory setting using the application software "MR-J4(W)-B mode selection", and then connect the servo amplifier through SSCNETIII/H.

The Mitsubishi Electric general-purpose AC servo MELSERVO-JE series have limited functions with keeping high performance based on MELSERVO-J4 series.

The MR-JE-_B servo amplifier is connected to controllers, including a servo system controller, on the high-speed synchronous network SSCNET III/H. The servo amplifier directly receives a command from a controller to drive a servo motor.

SSCNET III/H achieves high-speed communication of 150 Mbps full duplex with high noise tolerance due to the SSCNET III optical cables. Large amounts of data can be exchanged in real-time between the controller and the servo amplifier. Servo monitor information can be stored in the upper information system and used for control.

With one-touch tuning and real-time auto tuning, you can easily and automatically adjust the servo gains according to the machine.

The tough drive function, drive recorder function, and preventive maintenance support function strongly support machine maintenance.

The servo amplifier has a USB communication interface. Therefore, you can connect the servo amplifier to the personal computer with MR Configurator2 installed to perform the parameter setting, test operation, gain adjustment, and others.

The servo motor equipped with an absolute position encoder whose resolution is 131072 pulses/rev will enable a high-accuracy positioning.

1. FUNCTIONS AND CONFIGURATION

1.2 Function block diagram

The function block diagram of this servo is shown below.

(1) MR-JE-100B or less

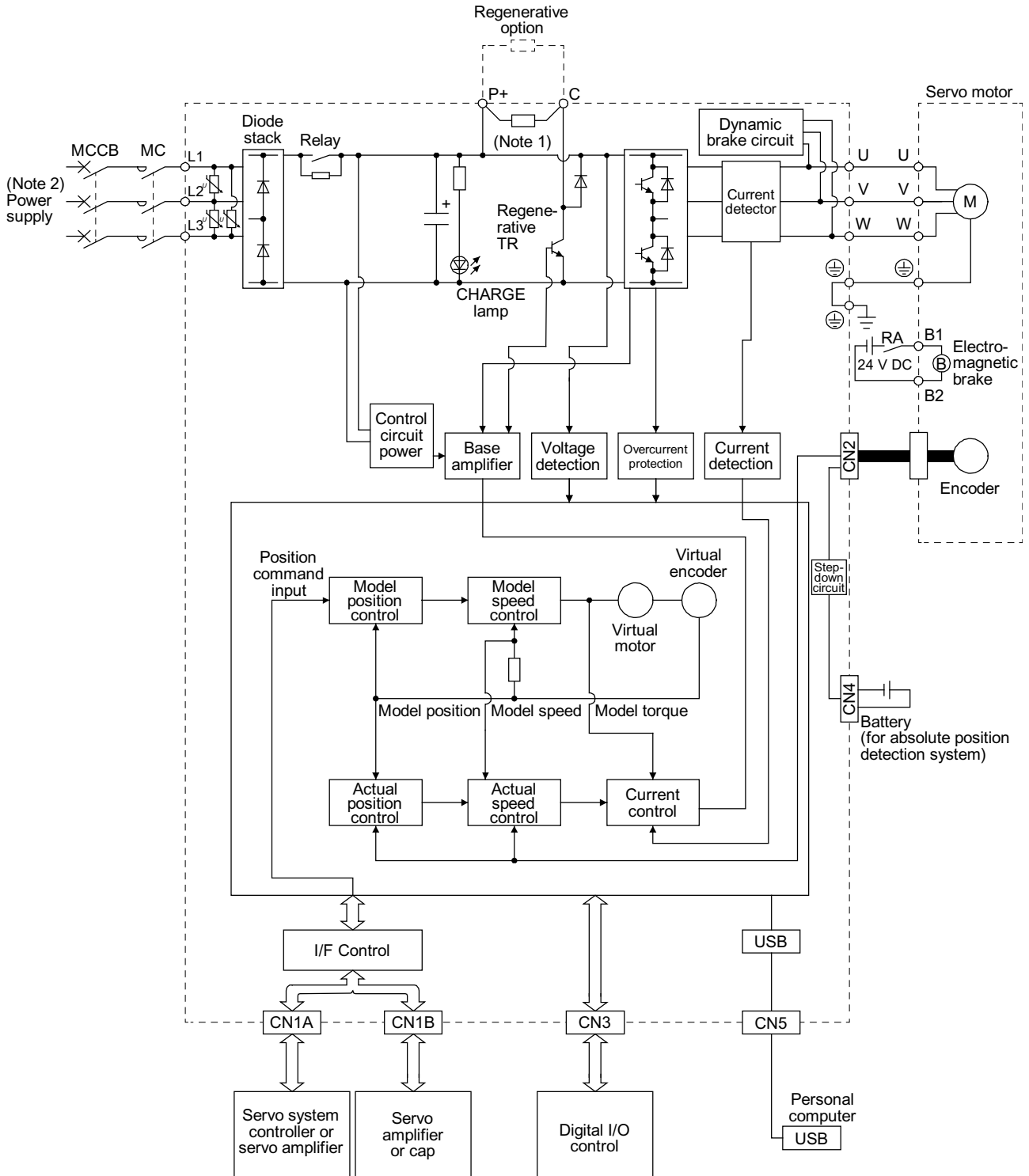

Note 1. The built-in regenerative resistor is not provided for MR-JE-10B and MR-JE-20B.

Note 2. For 1-phase 200 V AC to 240 V AC, connect the power supply to L1 and L3. Leave L2 open.

For the power supply specifications, refer to section 1.3.

1. FUNCTIONS AND CONFIGURATION

(2) MR-JE-200B or more

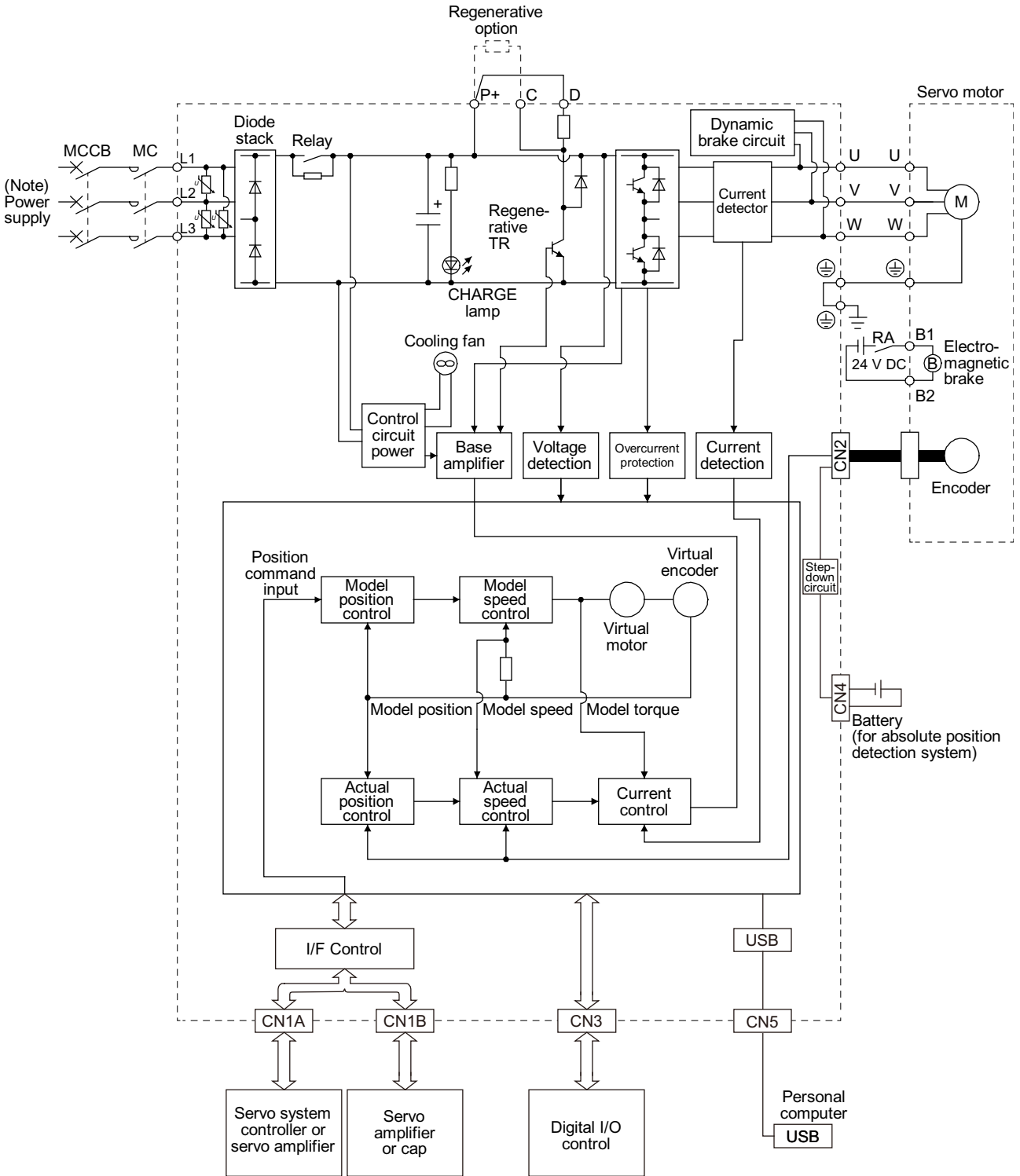

Note. A 1-phase 200 V AC to 240 V AC power supply may be used with the servo amplifier of MR-JE-200B. For 1-phase 200 V AC to 240 V AC, connect the power supply to L1 and L2. Leave L3 open. For the power supply specifications, refer to section 1.3.

1. FUNCTIONS AND CONFIGURATION

1.3 Servo amplifier standard specifications

Model: MR-JE-		10B	20B	40B	70B	100B	200B	300B	
Output	Rated voltage	3-phase 170 V AC							
	Rated current [A]	1.1	1.5	2.8	5.8	6.0	11.0	11.0	
Power supply input	Voltage/frequency	3-phase or 1-phase 200 V AC to 240 V AC, 50 Hz/60 Hz			3-phase or 1-phase 200 V AC to 240 V AC, 50 Hz/60 Hz (Note 5)			3-phase 200 V AC to 240 V AC, 50 Hz/60 Hz	
	Rated current (Note 1) [A]	0.9	1.5	2.6	3.8	5.0	10.5	14.0	
	Permissible voltage fluctuation	3-phase or 1-phase 170 V AC to 264 V AC			3-phase or 1-phase 170 V AC to 264 V AC (Note 5)			3-phase 170 V AC to 264 V AC	
	Permissible frequency fluctuation	Within $\pm 5\%$							
	Power supply capacity [kVA]	Refer to section 10.2.							
	Inrush current [A]	Refer to section 10.5.							
Interface power supply	Voltage	24 V DC $\pm 10\%$							
	Current capacity [A]	0.3 (Note 2)							
Control method	Sine-wave PWM control, current control method								
Dynamic brake	Built-in								
SSCNET III/H communication cycle (Note 3)	0.444 ms, 0.888 ms								
Communication function	USB: Connection to a personal computer or others (MR Configurator2-compatible)								
Protective functions	Overcurrent shut-off, regenerative overvoltage shut-off, overload shut-off (electronic thermal), servo motor overheat protection, encoder error protection, regenerative error protection, undervoltage protection, instantaneous power failure protection, overspeed protection, and error excessive protection								
Compliance with global standards	CE marking	LVD: EN 61800-5-1, EMC: EN 61800-3							
	UL standard	UL 508C							
Structure (IP rating)	Natural cooling, open (IP20)						Force cooling, open (IP20)		
Close mounting (Note 4)	3-phase power supply input	Possible							
	1-phase power supply input	Possible				Impossible			
Environment	Ambient temperature	Operation	0 °C to 55 °C (non-freezing)						
		Storage	-20 °C to 65 °C (non-freezing)						
	Ambient humidity	Operation	5 %RH to 90 %RH (non-condensing)						
		Storage							
	Ambience	Indoors (no direct sunlight); no corrosive gas, inflammable gas, oil mist or dust							
	Altitude	2000 m or less above sea level (Note 6)							
Vibration resistance	5.9 m/s ² , at 10 Hz to 55 Hz (directions of X, Y and Z axes)								
Mass [kg]	0.8		1.5			2.1			

- Note
1. This value is applicable when a 3-phase power supply is used.
 2. The current capacity 0.3 A is applicable when all I/O signals are used. The current capacity can be decreased by reducing the number of I/O points. For the servo amplifiers manufactured in April 2016 or earlier (or manufactured in China in May 2016 or earlier), the current capacity 0.1 A is applicable.
 3. The communication cycle depends on the controller specifications and the number of axes connected.
 4. When closely mounting the servo amplifiers, operate them at the ambient temperature of 0 °C to 45 °C or at 75% or smaller effective load ratio.
 5. When using 1-phase 200 V AC to 240 V AC power supply, operate the servo amplifier at 75% or smaller effective load ratio.
 6. Follow the restrictions in section 2.7 when using this product at altitude exceeding 1000 m and up to 2000 m above sea level.

1. FUNCTIONS AND CONFIGURATION

1.4 Combinations of servo amplifiers, servo motors, and controllers

1.4.1 Combinations of servo amplifiers and servo motors

Servo amplifier	Servo motor
MR-JE-10B	HG-KN13_
MR-JE-20B	HG-KN23_
MR-JE-40B	HG-KN43_
MR-JE-70B	HG-KN73_ HG-SN52_
MR-JE-100B	HG-SN102_
MR-JE-200B	HG-SN152_ HG-SN202_
MR-JE-300B	HG-SN302_

1.4.2 Compatible controller

For the compatible controllers, refer to the user's manual of each controller.

1. FUNCTIONS AND CONFIGURATION

1.5 Function list

The following table lists the functions of this servo. For details of the functions, refer to each section indicated in the detailed explanation field.

Function	Description	Detailed explanation
Model adaptive control	This function realizes a high response and stable control following the ideal model. The two-degrees-of-freedom model adaptive control enables you to set a response to the command and response to the disturbance separately. Additionally, this function can be disabled. Refer to section 7.4 to disable this function.	
Position control mode	This servo amplifier is used as a position control servo.	
Speed control mode	This servo amplifier is used as a speed control servo.	
Torque control mode	This servo amplifier is used as a torque control servo.	
High-resolution encoder	A high-resolution encoder of 131072 pulses/rev is used as the encoder of the rotary servo motor compatible with the MELSERVO-JE series.	
Absolute position detection system	Setting a home position once makes home position return unnecessary at every power-on.	Chapter 12
Gain switching function	You can switch gains during rotation and during stop, and can use input devices to switch gains during operation.	Section 7.2
Advanced vibration suppression control II	This function suppresses vibration at the arm end or residual vibration.	Section 7.1.5
Machine resonance suppression filter	This filter function (notch filter) decreases the gain of the specific frequency to suppress the resonance of the mechanical system.	Section 7.1.1
Shaft resonance suppression filter	When a load is mounted to the servo motor shaft, resonance by shaft torsion during driving may generate a mechanical vibration at high frequency. The shaft resonance suppression filter suppresses the vibration.	Section 7.1.3
Adaptive filter II	The servo amplifier detects mechanical resonance and sets filter characteristics automatically to suppress mechanical vibration.	Section 7.1.2
Low-pass filter	This function suppresses high-frequency resonance which occurs as servo system response is increased.	Section 7.1.4
Machine analyzer function	This function analyzes the frequency characteristic of the mechanical system by simply connecting an MR Configurator2 installed personal computer and servo amplifier. MR Configurator2 is necessary for this function.	
Robust filter	This function enhances the disturbance response when the response level remains low because the load to motor inertia ratio of axes, such as a roll feed axis, is high.	[Pr. PE41]
Slight vibration suppression control	This function suppresses vibration of ± 1 pulse generated at a servo motor stop.	[Pr. PB24]
Auto tuning	This function automatically adjusts the gain to an optimum value if load applied to the servo motor shaft varies.	Section 6.3
Regenerative option	Used when the built-in regenerative resistor of the servo amplifier does not have sufficient regenerative capability for the regenerative power generated.	Section 11.2
Alarm history clear	This function clears the alarm history.	[Pr. PC21]
Output signal selection (device settings)	The output devices including MBR (Electromagnetic brake interlock) and ALM (Malfunction) can be assigned to certain pins of the CN3 connector.	[Pr. PD07]
Output signal (DO) forced output	Output signal can be forced on/off independently of the servo status. Use this function for checking output signal wiring, etc.	Section 4.5.1 (1) (d)
Test operation mode	Jog operation, positioning operation, motor-less operation, DO forced output, and program operation MR Configurator2 is necessary for this function.	Section 4.5
MR Configurator2	Using a personal computer, you can perform the parameter setting, test operation, monitoring, and others.	Section 11.4
One-touch tuning	Gain adjustment is performed just by one click on a certain button on MR Configurator2. MR Configurator2 is necessary for this function.	Section 6.2
Tough drive function	This function makes the equipment continue operating even under the condition that an alarm occurs. The tough drive function includes two types: the vibration tough drive and the instantaneous power failure tough drive.	Section 7.3

1. FUNCTIONS AND CONFIGURATION

Function	Description	Detailed explanation
Drive recorder function	<p>This function continuously monitors the servo status and records the status transition before and after an alarm for a fixed period of time. You can check the recorded data on the drive recorder window on MR Configurator2 by clicking the "Graph" button. However, the drive recorder will not operate on the following conditions.</p> <ol style="list-style-type: none"> 1. You are using the graph function of MR Configurator2. 2. You are using the machine analyzer function. 3. [Pr. PF21] is set to "-1". 4. The controller is not connected (except the test operation mode). 5. An alarm related to the controller is occurring. 	[Pr. PA23]
Servo amplifier life diagnosis function	<p>You can check the cumulative energization time and the number of on/off times of the inrush relay. This function gives an indication of the replacement time for parts of the servo amplifier including a capacitor and a relay before they malfunction. MR Configurator2 is necessary for this function.</p>	
Power monitoring function	<p>This function calculates the power running energy and the regenerative power from the data in the servo amplifier such as speed and current. Power consumption and others are displayed on MR Configurator2. Since the servo amplifier sends data to a servo system controller, you can analyze the data and display the data on a display with the SSCNET III/H system.</p>	
Machine diagnosis function	<p>From the data in the servo amplifier, this function estimates the friction and vibrational component of the drive system in the equipment and recognizes an error in the machine parts, including a ball screw and bearing. MR Configurator2 is necessary for this function.</p>	
Continuous operation to torque control mode	<p>This function allows smooth switching of the mode from the position control mode or speed control mode to the torque control mode without stopping. This function eliminates rapid change of speed and torque, contributing to reduction in load to the machine and high-quality product molding. For details of the continuous operation to torque control mode, refer to the manuals for servo system controllers.</p>	[Pr. PB03] [Pr. PB09] Manuals of servo system controllers
Lost motion compensation function	<p>This function corrects response delays caused when the machine travel direction is reversed.</p>	Section 7.5
Hot line forced stop function	<p>When an alarm occurs in the MR-JE-_B servo amplifier, this function enables all the servo motors connected to normally operating MR-JE-_B servo amplifiers to decelerate to a stop by transmitting hot line forced stop signals via a controller.</p>	Section 3.7.3

1. FUNCTIONS AND CONFIGURATION

1.6 Model designation

(1) Rating plate

The following shows an example of the rating plate for explanation of each item.

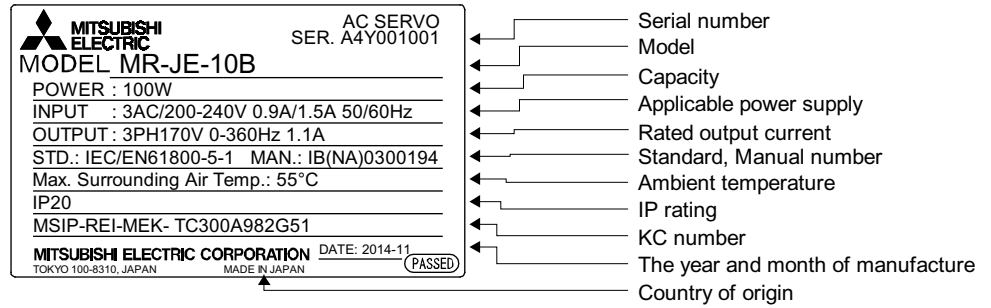

(2) Model

The following describes what each block of a model name indicates.

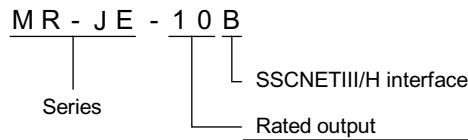

Symbol	Rated output [kW]
10	0.1
20	0.2
40	0.4
70	0.75
100	1
200	2
300	3

1. FUNCTIONS AND CONFIGURATION

1.7 Structure

1.7.1 Parts identification

(1) MR-JE-100B or less

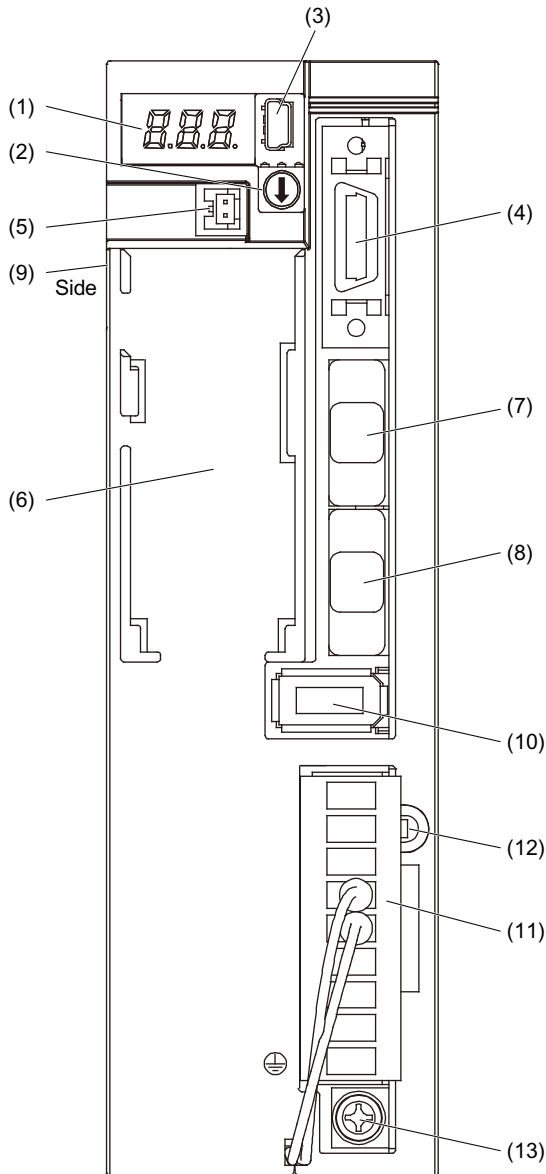

No.	Name/Application	Detailed explanation
(1)	Display The 3-digit, 7-segment LED shows the servo status and the alarm number.	Section 4.3
(2)	Axis selection rotary switch (SW1) Used to set the axis number of the servo amplifier.	
(3)	USB communication connector (CN5) Used to connect this connector to a personal computer.	Section 11.4
(4)	I/O signal connector (CN3) Used to connect digital I/O signals.	Section 3.2 Section 3.4
(5)	Battery connector (CN4) Used to connect the battery for absolute position data backup.	Chapter 12
(6)	Battery holder Used to house the battery for absolute position data backup.	
(7)	SSCNET III cable connector (CN1A) Used to connect the servo system controller or the previous axis servo amplifier.	Section 3.2
(8)	SSCNET III cable connector (CN1B) Used to connect the next axis servo amplifier. For the final axis, put a cap.	Section 3.4
(9)	Rating plate	Section 1.6
(10)	Encoder connector (CN2) Used to connect the servo motor encoder.	Section 3.4
(11)	Power connector (CNP1) Used to connect the input power supply, built-in regenerative resistor, regenerative option, and servo motor.	Section 3.1 Section 3.3
(12)	Charge lamp When the main circuit is charged, this lamp will light up. While this lamp is lit, do not reconnect the cables.	
(13)	Protective earth (PE) terminal	Section 3.1 Section 3.3

1. FUNCTIONS AND CONFIGURATION

(2) MR-JE-200B or more

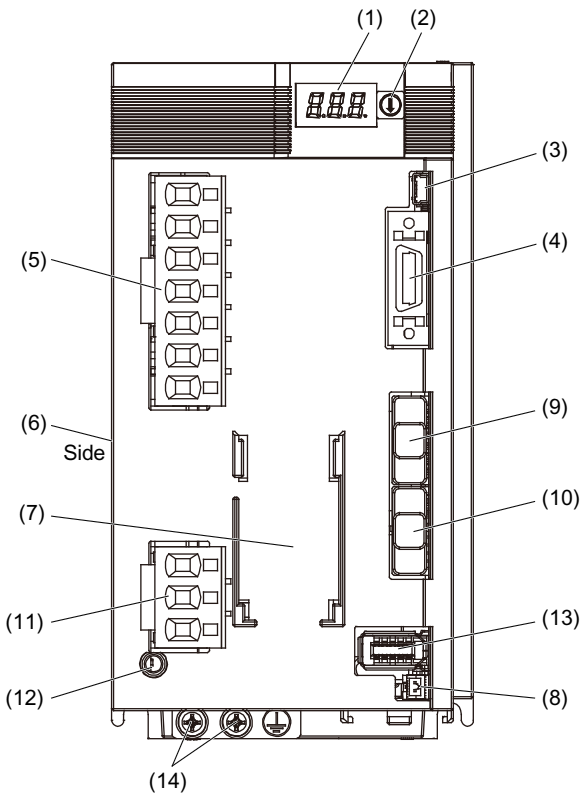

No.	Name/Application	Detailed explanation
(1)	Display The 3-digit, 7-segment LED shows the servo status and the alarm number.	Section 4.3
(2)	Axis selection rotary switch (SW1) Used to set the axis number of the servo amplifier.	
(3)	USB communication connector (CN5) Used to connect this connector to a personal computer.	Section 11.4
(4)	I/O signal connector (CN3) Used to connect digital I/O signals.	Section 3.2 Section 3.4
(5)	Power connector (CNP1) Used to connect the input power supply and regenerative option.	Section 3.1 Section 3.3
(6)	Rating plate	Section 1.6
(7)	Battery holder Used to house the battery for absolute position data backup.	Chapter 12
(8)	Battery connector (CN4) Used to connect the battery for absolute position data backup.	
(9)	SSCNET III cable connector (CN1A) Used to connect the servo system controller or the previous axis servo amplifier.	Section 3.2
(10)	SSCNET III cable connector (CN1B) Used to connect the next axis servo amplifier. For the final axis, put a cap.	Section 3.4
(11)	Servo motor power connector (CNP2) Used to connect the servo motor.	Section 3.1 Section 3.3
(12)	Charge lamp When the main circuit is charged, this lamp will light up. While this lamp is lit, do not reconnect the cables.	
(13)	Encoder connector (CN2) Used to connect the servo motor encoder.	Section 3.4
(14)	Protective earth (PE) terminal	Section 3.1 Section 3.3

1. FUNCTIONS AND CONFIGURATION

1.8 Configuration including peripheral equipment



● Connecting a servo motor of the wrong axis to U, V, W, or CN2 of the servo amplifier may cause a malfunction.

POINT

● Equipment other than the servo amplifier and servo motor are optional or recommended products.

(1) MR-JE-100B or less

The diagram shows MR-JE-40B.

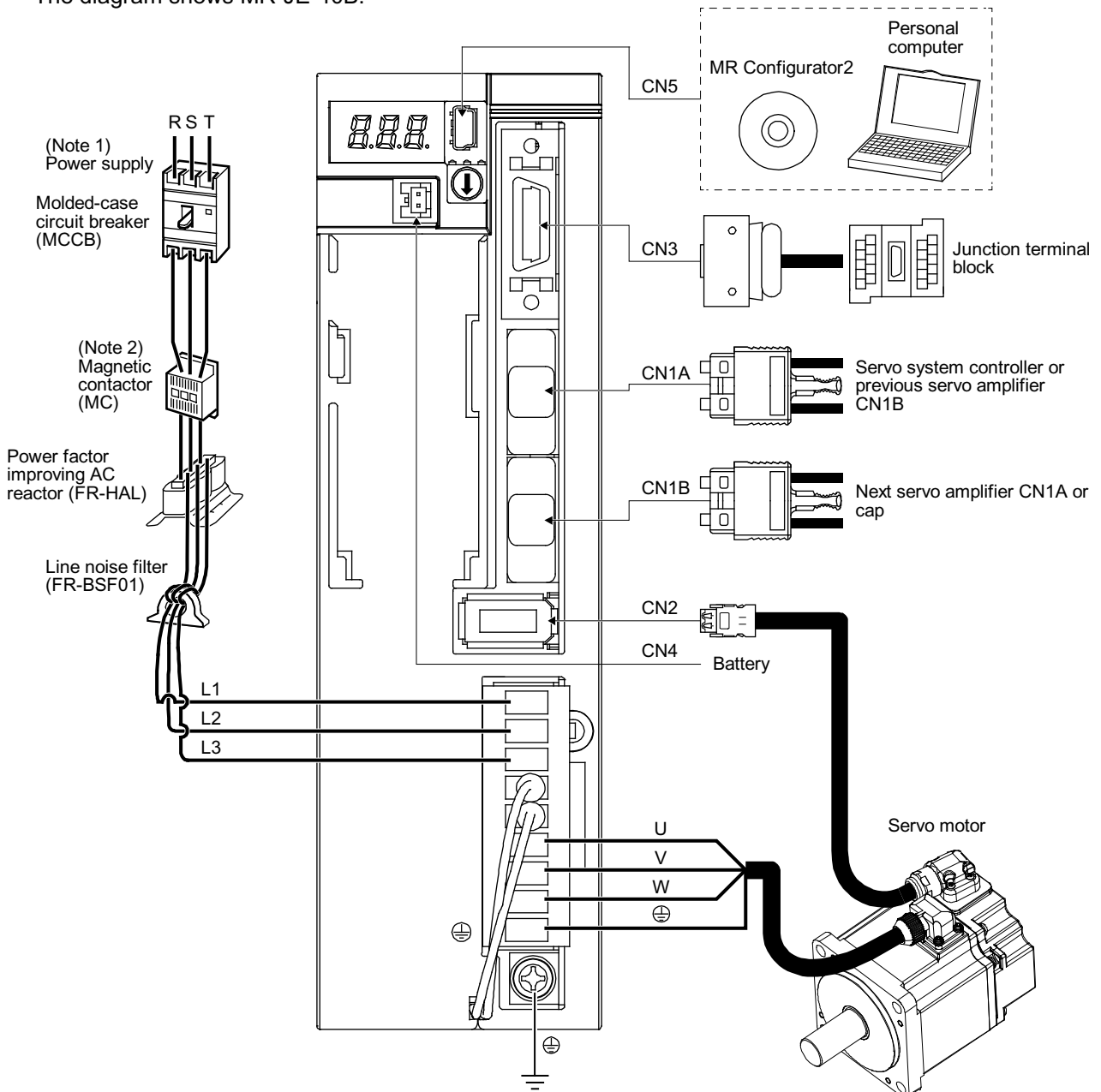

- Note 1. For 1-phase 200 V AC to 240 V AC, connect the power supply to L1 and L3. Leave L2 open. For the power supply specifications, refer to section 1.3.
- Note 2. Depending on the power supply voltage and operation pattern, bus voltage can decrease. This can shift the mode to the dynamic brake deceleration during forced stop deceleration. When dynamic brake deceleration is not required, slow the time to turn off the magnetic contactor.

1. FUNCTIONS AND CONFIGURATION

(2) MR-JE-200B or more

The diagram shows MR-JE-200B.

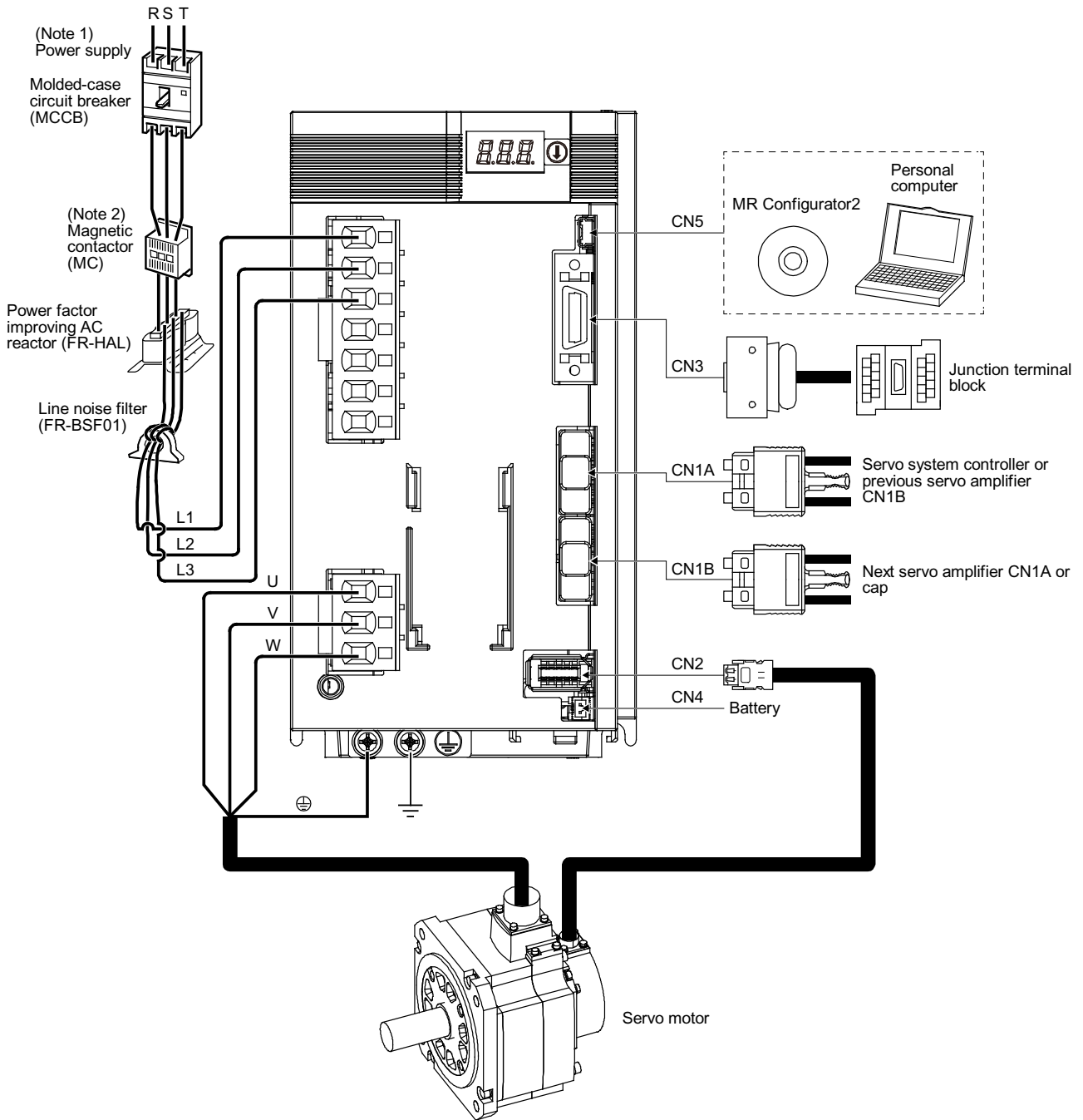

- Note 1. A 1-phase 200 V AC to 240 V AC power supply may be used with the servo amplifier of MR-JE-200B. For 1-phase 200 V AC to 240 V AC, connect the power supply to L1 and L2. Leave L3 open. For the power supply specifications, refer to section 1.3.
- Note 2. Depending on the power supply voltage and operation pattern, bus voltage can decrease. This can shift the mode to the dynamic brake deceleration during forced stop deceleration. When dynamic brake deceleration is not required, slow the time to turn off the magnetic contactor.

2. INSTALLATION

2. INSTALLATION



WARNING ● To prevent electric shock, ground each equipment securely.



CAUTION

- Stacking in excess of the specified number of product packages is not allowed.
- Do not hold the lead of the built-in regenerative resistor, cables, or connectors when carrying the servo amplifier. Otherwise, it may drop.
- Install the equipment on incombustible material. Installing them directly or close to combustibles will lead to smoke or a fire.
- Install the servo amplifier and the servo motor in a load-bearing place in accordance with the Instruction Manual.
- Do not get on or put heavy load on the equipment. Otherwise, it may cause injury.
- Use the equipment within the specified environment. For the environment, refer to section 1.3.
- Provide an adequate protection to prevent screws and other conductive matter, oil and other combustible matter from entering the servo amplifier.
- Do not block the intake and exhaust areas of the servo amplifier. Otherwise, it may cause a malfunction.
- Do not drop or apply heavy impact on the servo amplifiers and the servo motors. Otherwise, injury, malfunction, etc. may occur.
- Do not install or operate the servo amplifier which has been damaged or has any parts missing.
- When the product has been stored for an extended period of time, contact your local sales office.
- When handling the servo amplifier, be careful about the edged parts such as corners of the servo amplifier.
- The servo amplifier must be installed in a metal cabinet.
- When fumigants that contain halogen materials, such as fluorine, chlorine, bromine, and iodine, are used for disinfecting and protecting wooden packaging from insects, they cause malfunction when entering our products. Please take necessary precautions to ensure that remaining materials from fumigant do not enter our products, or treat packaging with methods other than fumigation, such as heat treatment. Additionally, disinfect and protect wood from insects before packing the products.

2. INSTALLATION

2.1 Installation direction and clearances



CAUTION

- The equipment must be installed in the specified direction. Otherwise, it may cause a malfunction.
- Leave specified clearances between the servo amplifier and the cabinet walls or other equipment. Otherwise, it may cause a malfunction.

MR-JE-40B to MR-JE-100B have a regenerative resistor on their back face. The regenerative resistor generates heat of 100 °C higher than the ambient temperature. Please fully consider heat dissipation, installation position, etc. when installing the servo amplifier.

(1) Installation clearances of the servo amplifier

(a) Installation of one servo amplifier

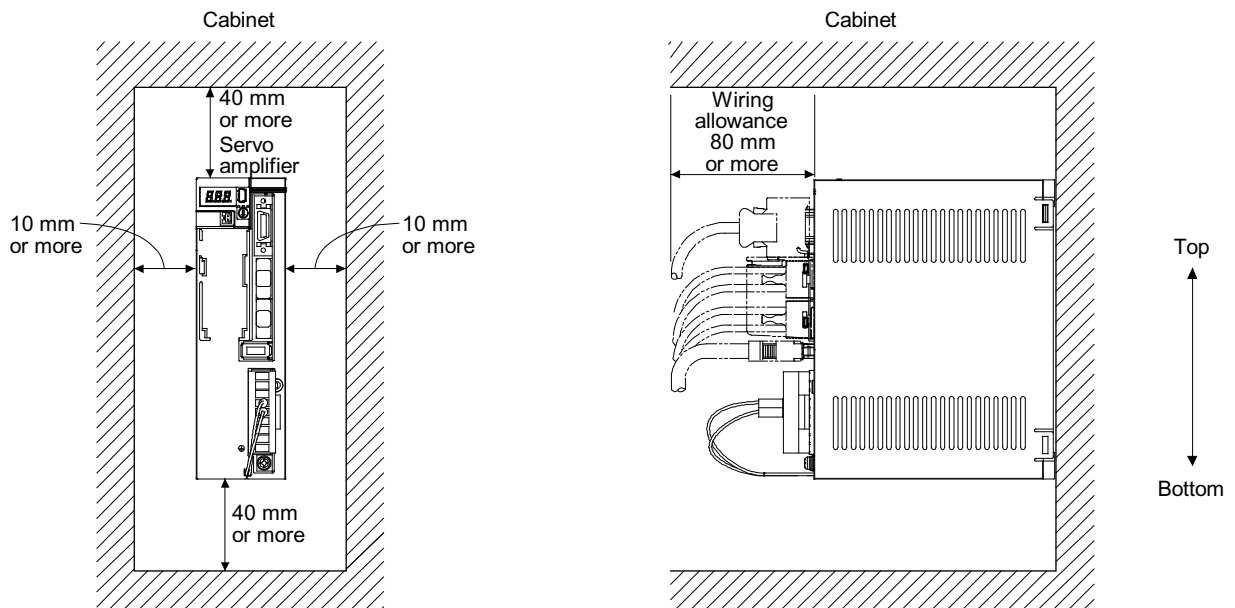

2. INSTALLATION

(b) Installation of two or more servo amplifiers

POINT
● Close mounting is possible depending on the capacity of the servo amplifier. Refer to section 1.3 for availability of close mounting.

Leave a large clearance between the top of the servo amplifier and the cabinet walls, and install a cooling fan to prevent the internal temperature of the cabinet from exceeding the environment. When mounting the servo amplifiers closely, leave a clearance of 1 mm between the adjacent servo amplifiers in consideration of mounting tolerances. In this case, keep the ambient temperature within 0 °C to 45 °C or use the servo amplifier with 75% or lower of the effective load ratio.

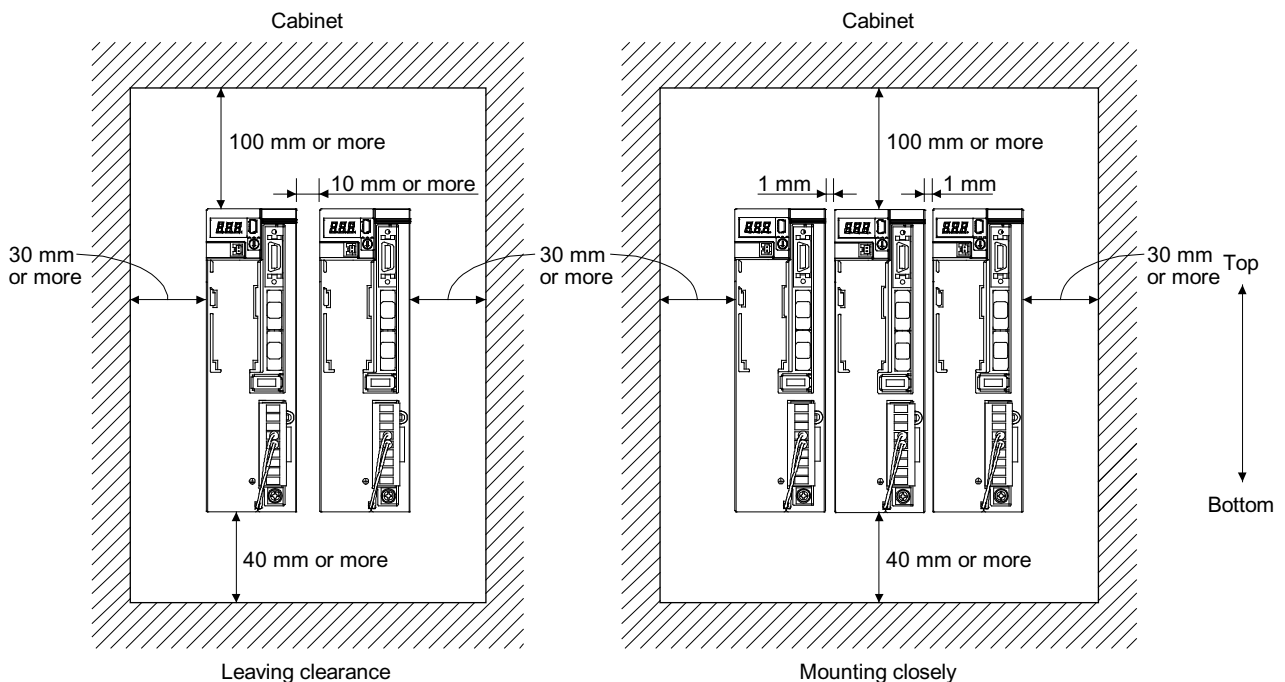

(2) Others

When using heat generating equipment such as the regenerative option, install them with full consideration of heat generation so that the servo amplifier is not affected.

Install the servo amplifier on a perpendicular wall in the correct vertical direction.

2.2 Keep out foreign materials

- (1) When drilling the cabinet, prevent drill chips and wire fragments from entering the servo amplifier.
- (2) Prevent oil, water, metallic dust, etc. from entering the servo amplifier through openings in the cabinet or a cooling fan installed on the ceiling.
- (3) When installing the cabinet in a place where toxic gas, dirt, and dust exist, conduct an air purge (force clean air into the cabinet from outside to make the internal pressure higher than the external pressure) to prevent such materials from entering the cabinet.

2. INSTALLATION

2.3 Encoder cable stress

- (1) The way of clamping the cable must be fully examined so that bending stress and cable's own weight stress are not applied to the cable connection.
- (2) For use in any application where the servo motor moves, fix the cables (encoder, power supply, and brake) with having some slack from the connector connection part of the servo motor to avoid putting stress on the connector connection part. Use the optional encoder cable within the bending life range. Use the power supply and brake wiring cables within the bending life of the cables.
- (3) Avoid any probability that the cable insulator might be cut by sharp chips, rubbed by a machine corner, or stamped by workers or vehicles.
- (4) For installation on a machine where the servo motor moves, the flexing radius should be made as large as possible. Refer to section 10.4 for the bending life.

2.4 SSCNET III cable laying

The SSCNET III cable is made from optical fiber. If power such as a major shock, lateral pressure, haul, sudden bending, or twist is applied to the optical fiber, its inside distorts or breaks, and optical transmission will not be available. Especially, as the optical fiber for MR-J3BUS_M/MR-J3BUS_M-A is made of synthetic resin, it melts down if being left near the fire or high temperature. Therefore, do not make it touch the part that can become hot such as heat sink or regenerative option of the servo amplifier.

Read described item in this section carefully and handle the SSCNET III cable with caution.

(1) Minimum bending radius

Make sure to lay the cable with greater radius than the minimum bending radius. Do not press the cable to edges of equipment or others. For the SSCNET III cable, the appropriate length should be selected with due consideration for the dimensions and arrangement of the servo amplifier. When closing the door of the cabinet, pay careful attention to avoid the case that the SSCNET III cable is held down by the door and the cable bend becomes smaller than the minimum bending radius. For the minimum bending radius, refer to section 11.1.2.

(2) Prohibition of vinyl tape use

Migrating plasticizer is used for vinyl tape. Keep the MR-J3BUS_M, and MR-J3BUS_M-A cables away from vinyl tape because the optical characteristic may be affected.

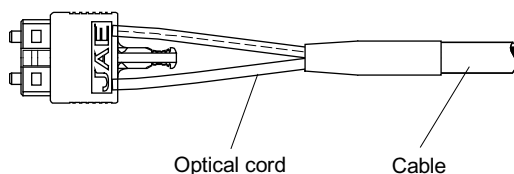

SSCNET III cable	Cord	Cable
MR-J3BUS_M	△	△
MR-J3BUS_M-A	△	△
MR-J3BUS_M-B	○	○

△: Phthalate ester plasticizer such as DBP and DOP may affect optical characteristic of the cable.

○: The cord and cable are not basically affected by plasticizer.

2. INSTALLATION

(3) Precautions for migrating plasticizer added materials

Generally, soft polyvinyl chloride (PVC), polyethylene resin (PE), and fluorine resin contain non-migrating plasticizer and they do not affect the optical characteristic of the SSCNET III cable. However, some wire sheaths and cable ties that contain migrating plasticizer (phthalate ester) may affect MR-J3BUS_M and MR-J3BUS_M-A cables (plastic).

In addition, the MR-J3BUS_M-B cable (silica glass) is not affected by plasticizer.

A chemical substance may affect its optical characteristic. Therefore, previously check that the cable is not affected by the environment.

(4) Bundle fixing

Fix the cable at the closest part to the connector with bundle material in order to prevent the SSCNET III cable from putting its own weight on the CN1A/CN1B connector of the servo amplifier. The optical cord should be given loose slack to avoid becoming smaller than the minimum bending radius, and it should not be twisted.

When bundling the cable, fix and hold it in position by using cushioning such as sponge or rubber which does not contain migratable plasticizers.

If adhesive tape for bundling the cable is used, fire resistant acetate cloth adhesive tape 570F (Teraoka Seisakusho Co., Ltd) is recommended.

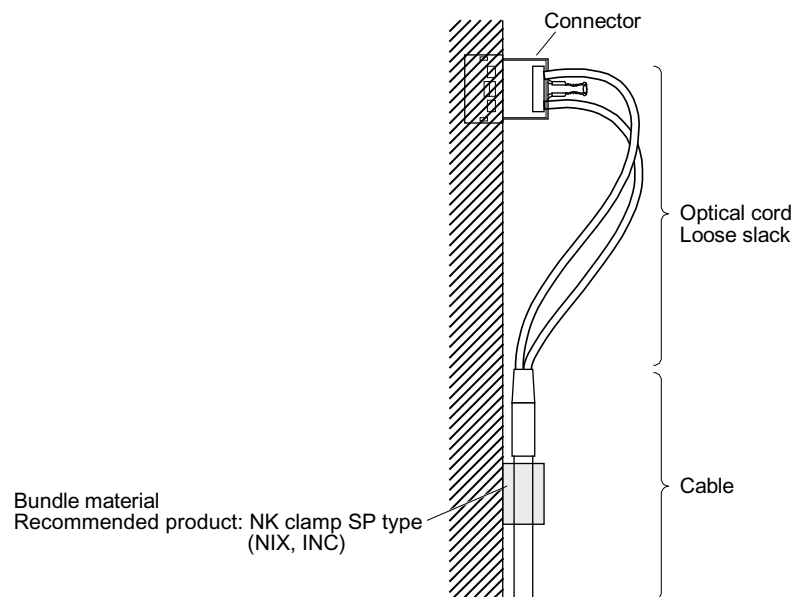

(5) Tension

If tension is added on an optical cable, the increase of transmission loss occurs because of external force which concentrates on the fixing part of the optical fiber or the connecting part of the optical connector. Doing so may cause the breakage of the optical fiber or damage of the optical connector. For cable laying, handle the cable without putting forced tension. For the tension strength, refer to section 11.1.2.

(6) Lateral pressure

If lateral pressure is added on an optical cable, the optical cable itself distorts, the internal optical fiber gets stressed, and then transmission loss will increase. Doing so may cause the breakage of the optical cable. As the same condition occurs when the cables are bundled, do not tighten the optical cable with a nylon band (cable tie) or a similar material.

Do not trample it down or tuck it down with the door of the cabinet or others.

2. INSTALLATION

(7) Twisting

If optical fiber is twisted, it will become the same stress added condition as when local lateral pressure or bend is added. Consequently, transmission loss increases, and the breakage of the optical fiber may occur.

(8) Disposal

When the optical cable (cord) used for an SSCNET III cable, hydrogen fluoride gas or hydrogen chloride gas which is corrosive and harmful may be generated. For disposal of optical fiber, request for specialized industrial waste disposal services who has incineration facility for disposing hydrogen fluoride gas or hydrogen chloride gas.

2.5 Inspection items

 WARNING	<ul style="list-style-type: none">● Before starting maintenance and/or inspection, turn off the power and wait for 15 minutes or more until the charge lamp turns off. Otherwise, an electric shock may occur. In addition, when confirming whether the charge lamp is off or not, always confirm it from the front of the servo amplifier.● To avoid an electric shock, only qualified personnel should attempt inspections. For repair and parts replacement, contact your local sales office.
--	---

 CAUTION	<ul style="list-style-type: none">● Do not perform insulation resistance test on the servo amplifier. Otherwise, it may cause a malfunction.● Do not disassemble and/or repair the equipment on customer side.
--	---

It is recommended that the following points periodically be checked.

- (1) Check for loose terminal block screws. Retighten any loose screws.
- (2) Check for scratches and cracks of cables and the like. Inspect them periodically according to operating conditions especially when the servo motor is movable.
- (3) Check that the connector is securely connected to the servo amplifier.
- (4) Check that the wires are not coming out from the connector.
- (5) Check for dust accumulation on the servo amplifier.
- (6) Check for unusual noise generated from the servo amplifier.
- (7) Make sure that the emergency stop circuit operates properly such that an operation can be stopped immediately and a power is shut off by the emergency stop switch.

2. INSTALLATION

2.6 Parts having service life

Service life of the following parts is listed below. However, the service life varies depending on operating methods and environment. If any fault is found in the parts, they must be replaced immediately regardless of their service life. For parts replacement, please contact your local sales office.

Part name	Life guideline
Smoothing capacitor	10 years
Relay	Number of power-on, forced stop by EM1 (Forced stop 1), and controller forced stop times: 100,000 times
Cooling fan	50,000 hours to 70,000 hours (7 years to 8 years)
Absolute position battery	Refer to section 12.2.

(1) Smoothing capacitor

The characteristic of a smoothing capacitor is deteriorated due to ripple currents, etc. The life of the capacitor greatly depends on ambient temperature and operating conditions. The capacitor will reach the end of its life in 10 years of continuous operation in normal air-conditioned environment (ambient temperature of 40 °C or less).

(2) Relays

Contact faults will occur due to contact wear arisen from switching currents. Relays will reach the end of their lives depending on their power supply capacity when the number of power-on times, number of forced stop times by EM1 (Forced stop 1), and number of controller forced stop times are 100,000 times in total.

(3) Servo amplifier cooling fan

The cooling fan bearings reach the end of their lives in 50,000 hours to 70,000 hours. Normally, therefore, the cooling fan must be replaced in seven to eight years of continuous operation as a guideline. If unusual noise or vibration is found during inspection, the cooling fan must also be replaced. The life indicates under the yearly average ambient temperature of 40 °C, free from corrosive gas, flammable gas, oil mist, dust, and dirt.

2. INSTALLATION

2.7 Restrictions when using this product at altitude exceeding 1000 m and up to 2000 m above sea level

(1) Effective load ratio and regenerative load ratio

As heat dissipation effects decrease in proportion to the decrease in air density, use the product within the effective load ratio and regenerative load ratio shown in the following figure.

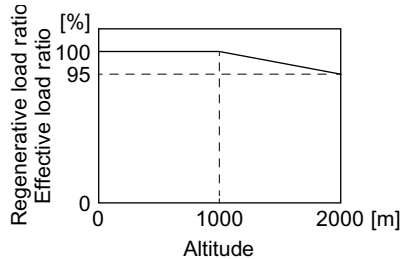

When closely mounting the servo amplifiers, operate them at the ambient temperature of 0 °C to 45 °C or at 75% or smaller effective load ratio. (Refer to section 2.1.)

(2) Input voltage

Generally, a withstand voltage decreases as the altitude increases; however, there is no restriction on the withstand voltage. Use in the same manner as in 1000 m or less. (Refer to section 1.3.)

(3) Parts having service life

(a) Smoothing capacitor

The capacitor will reach the end of its life in 10 years of continuous operation in air-conditioned environment (ambient temperature of 30 °C or less).

(b) Relay

There is no restriction. Use in the same manner as in 1000 m or less. (Refer to section 2.6.)

(c) Servo amplifier cooling fan

There is no restriction. Use in the same manner as in 1000 m or less. (Refer to section 2.6.)

3. SIGNALS AND WIRING

3. SIGNALS AND WIRING

⚠ WARNING

- Any person who is involved in wiring should be fully competent to do the work.
- Before wiring, turn off the power and wait for 15 minutes or more until the charge lamp turns off. Otherwise, an electric shock may occur. In addition, when confirming whether the charge lamp is off or not, always confirm it from the front of the servo amplifier.
- Ground the servo amplifier and servo motor securely.
- Do not attempt to wire the servo amplifier and servo motor until they have been installed. Otherwise, it may cause an electric shock.
- The cables should not be damaged, stressed, loaded, or pinched. Otherwise, it may cause an electric shock.
- To avoid an electric shock, insulate the connections of the power supply terminals.

- Before removing the CNP1 connector from MR-JE-40B to MR-JE-100B, disconnect the lead wires of the regenerative resistor from the CNP1 connector.
- Wire the equipment correctly and securely. Otherwise, the servo motor may operate unexpectedly, resulting in injury.
- Connect cables to the correct terminals. Otherwise, a burst, damage, etc. may occur.
- Ensure that polarity (+/-) is correct. Otherwise, a burst, damage, etc. may occur.
- The surge absorbing diode installed to the DC relay for control output should be fitted in the specified direction. Otherwise, the emergency stop and other protective circuits may not operate.

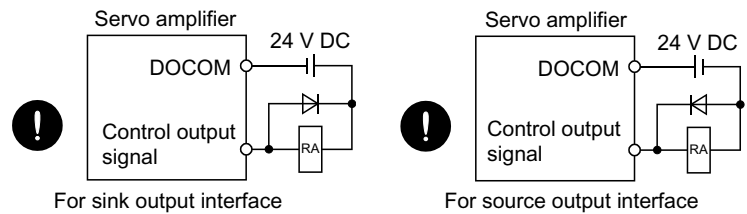

⚠ CAUTION

- Use a noise filter, etc. to minimize the influence of electromagnetic interference. Electromagnetic interference may be given to the electronic equipment used near the servo amplifier.
- Do not install a power capacitor, surge killer, or radio noise filter (optional FR-BIF) with the power line of the servo motor.
- When using a regenerative resistor, switch power off with the alarm signal. Otherwise, a transistor fault or the like may overheat the regenerative resistor, causing a fire.
- Do not modify the equipment.
- Connect the servo amplifier power output (U/V/W) to the servo motor power input (U/V/W) directly. Do not let a magnetic contactor, etc. intervene. Otherwise, it may cause a malfunction.

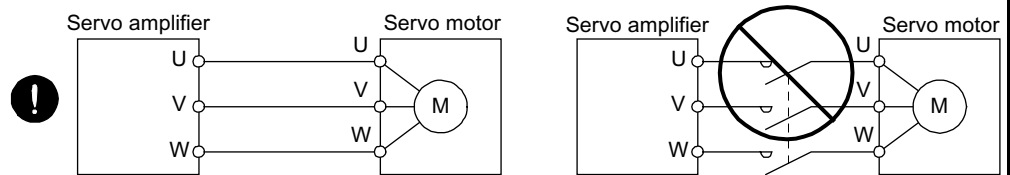

3. SIGNALS AND WIRING

CAUTION

- Connecting a servo motor of the wrong axis to U, V, W, or CN2 of the servo amplifier may cause a malfunction.
- Before wiring, switch operation, etc., eliminate static electricity. Otherwise, it may cause a malfunction.

3.1 Input power supply circuit

CAUTION

- Always connect a magnetic contactor between the power supply and the power supply (L1/L2/L3) of the servo amplifier, in order to configure a circuit that shuts down the power supply on the side of the servo amplifier's power supply. If a magnetic contactor is not connected, continuous flow of a large current may cause a fire when the servo amplifier malfunctions.
- Use an alarm to switch power off. Not doing so may cause a fire when a regenerative transistor malfunction or the like may overheat the regenerative resistor.
- Before removing the CNP1 connector from MR-JE-40B to MR-JE-100B, disconnect the lead wires of the regenerative resistor from the CNP1 connector. Not doing so may break the lead wires of the regenerative resistor.
- Check the servo amplifier model, and then input proper voltage to the servo amplifier power supply. If input voltage exceeds the upper limit of the specification, the servo amplifier will break down.
- The servo amplifier has a built-in surge absorber (varistor) to reduce exogenous noise and to suppress lightning surge. Exogenous noise or lightning surge deteriorates the varistor characteristics, and the varistor may be damaged. To prevent a fire, use a molded-case circuit breaker or fuse for input power supply.
- Connecting a servo motor of the wrong axis to U, V, W, or CN2 of the servo amplifier may cause a malfunction.
- N- terminal is not a neutral point of the power supply. Incorrect wiring will cause a burst, damage, etc. The servo amplifiers without the N- terminal will be available sequentially from the December 2016 production.

POINT

- EM2 has the same function as EM1 in the torque control mode.
- When a 1-phase 200 V AC to 240 V AC power supply is used, the connection destination differs depending on the servo amplifier. Ensure that the connection destination is correct.

Configure the wiring so that the power supply is shut off and the servo-on command is turned off after deceleration to a stop due to an alarm occurring, an enabled servo forced stop, or an enabled controller forced stop. A molded-case circuit breaker (MCCB) must be used with the input cables of the power supply.

3. SIGNALS AND WIRING

(1) Using 3-phase 200 V AC to 240 V AC power supply for MR-JE-10B to MR-JE-100B

POINT
<ul style="list-style-type: none"> ● For MR-JE-_B servo amplifiers, the hot line forced stop function is enabled at factory setting. For MR-J4-_B servo amplifiers, the hot line forced stop function is disabled at factory setting. ● If an alarm occurs, the hot line forced stop function outputs hot line forced stop signals to all servo amplifiers before a communication to the controller is cut. Then, the servo amplifiers will be in the [AL. E7.1 Controller forced stop input warning] state, and the servo motors will decelerate to a stop. ● The hot line forced stop function can be disabled with [Pr. PA27]. ● Configure the power supply circuit which turns off magnetic contactors of all servo amplifiers after detection of alarm occurrence on the controller side at alarm occurrence.

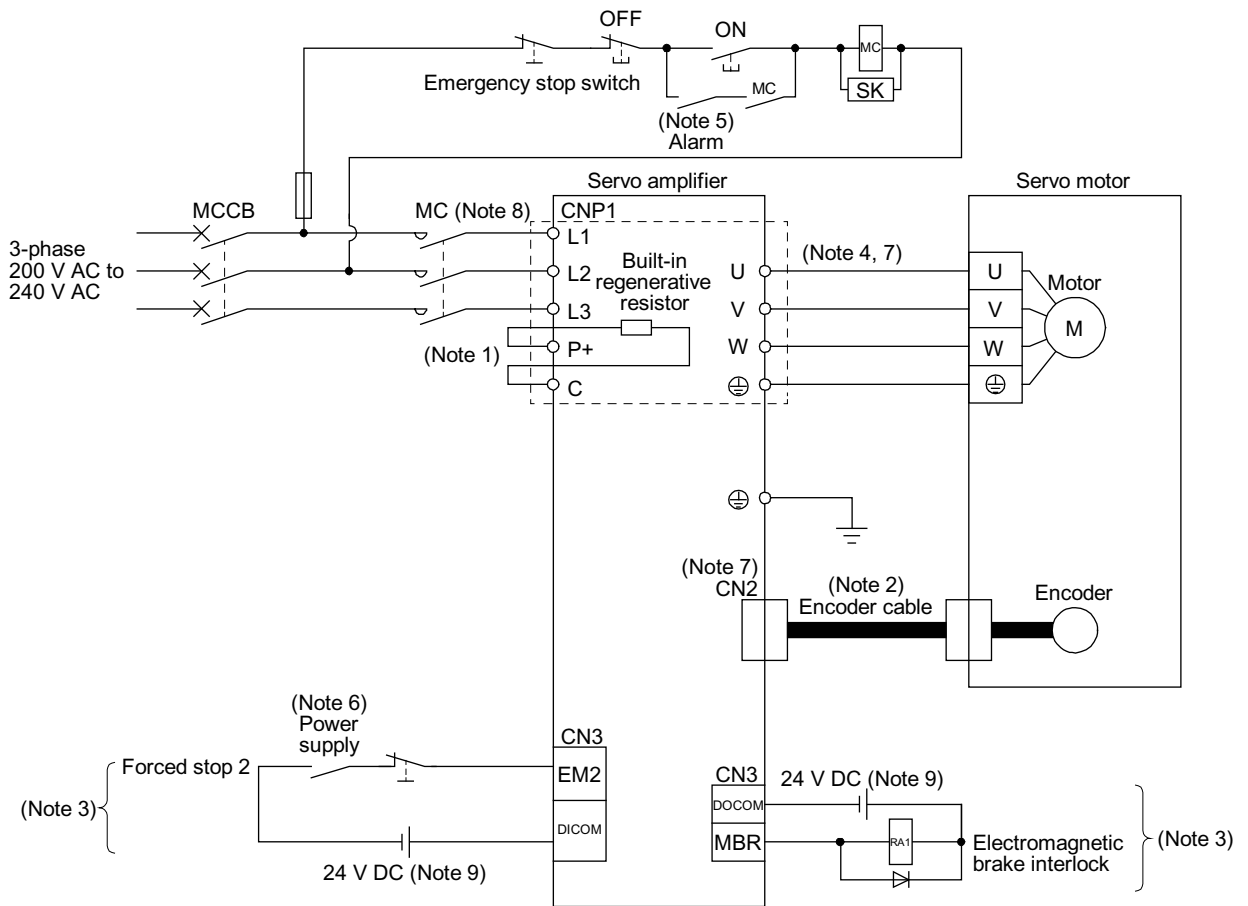

3. SIGNALS AND WIRING

- Note
1. MR-JE-40B to MR-JE-100B have a built-in regenerative resistor. (factory-wired) When using the regenerative option, refer to section 11.2.
 2. For the encoder cable, use of the option cable is recommended. For cable selection, refer to "HG-KN_/HG-SN_ Servo Motor Instruction Manual".
 3. This diagram shows sink I/O interface. For source I/O interface, refer to section 3.8.3.
 4. For connection of servo motor power wires, refer to "HG-KN_/HG-SN_ Servo Motor Instruction Manual".
 5. Configure the power supply circuit that turns off the magnetic contactor after an alarm occurs on the controller side. To assign ALM (Malfunction) to a pin of the CN3 connector, set [Pr. PD08] or [Pr. PD09] to "_ _ 0 3".
 6. Configure a circuit to turn off EM2 when the power is turned off to prevent an unexpected restart of the servo amplifier.
 7. Connecting a servo motor of the wrong axis to U, V, W, or CN2 of the servo amplifier may cause a malfunction.
 8. Use a magnetic contactor with an operation delay time (interval since a current is applied to the coil until the contact closes) of 80 ms or shorter. Depending on the power supply voltage and operation pattern, bus voltage can decrease. This can shift the mode to the dynamic brake deceleration during forced stop deceleration. When dynamic brake deceleration is not required, slow the time to turn off the magnetic contactor.
 9. The illustration of the 24 V DC power supply is divided between input signal and output signal for convenience. However, they can be configured by one.

3. SIGNALS AND WIRING

(2) Using 1-phase 200 V AC to 240 V AC power supply for MR-JE-10B to MR-JE-100B

POINT
<ul style="list-style-type: none"> ● For MR-JE-_B servo amplifiers, the hot line forced stop function is enabled at factory setting. For MR-J4-_B servo amplifiers, the hot line forced stop function is disabled at factory setting. ● If an alarm occurs, the hot line forced stop function outputs hot line forced stop signals to all servo amplifiers before a communication to the controller is cut. Then, the servo amplifiers will be in the [AL. E7.1 Controller forced stop input warning] state, and the servo motors will decelerate to a stop. ● The hot line forced stop function can be disabled with [Pr. PA27]. ● Configure the power supply circuit which turns off magnetic contactors of all servo amplifiers after detection of alarm occurrence on the controller side at alarm occurrence. ● Connect the 1-phase 200 V AC to 240 V AC power supply to L1 and L3. One of the connecting destinations is different from MR-JE-200B Servo Amplifier's. ● You can use the neutral point of a 3-phase 400 V AC class power supply to input a 1-phase 200 V AC class power supply to the servo amplifier. Refer to app. 10 for details.

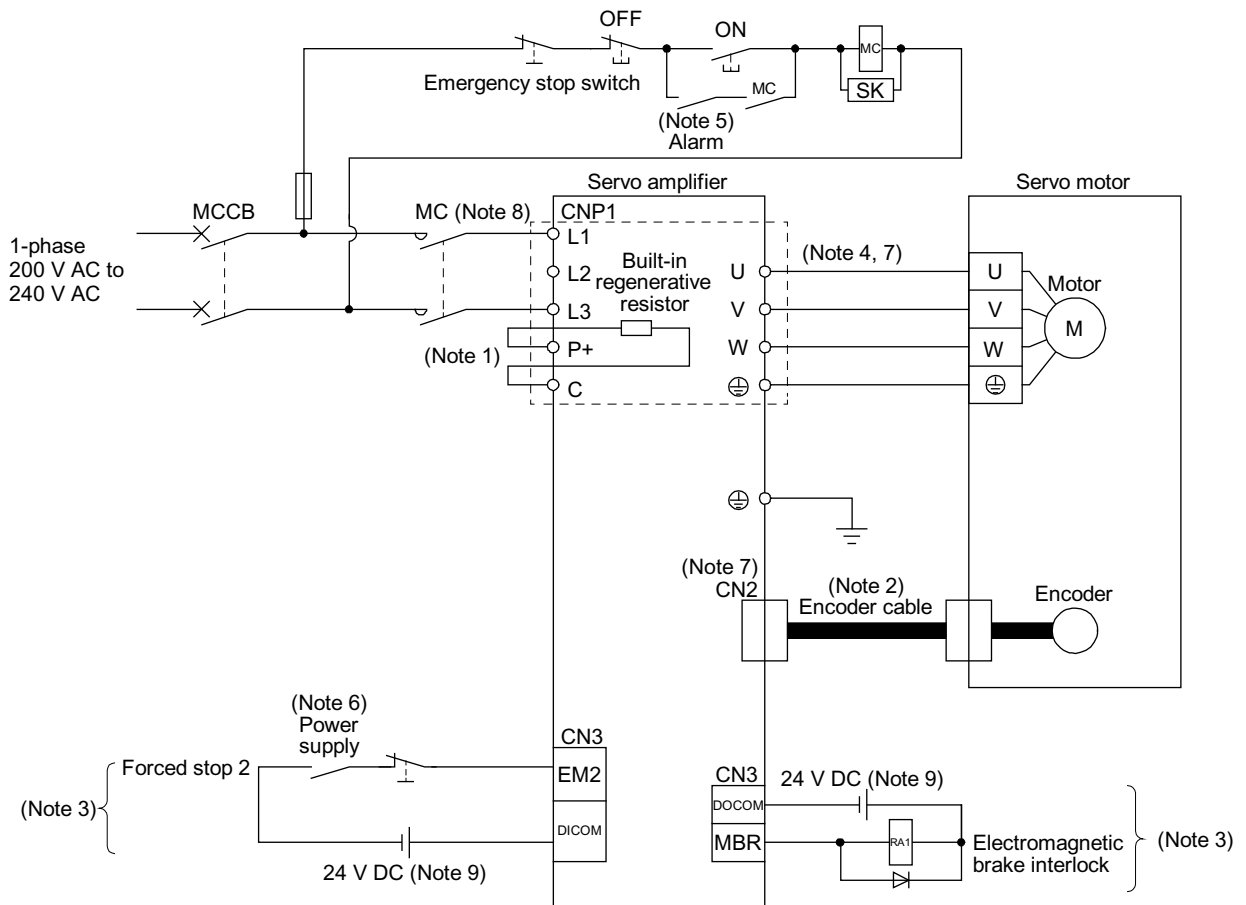

3. SIGNALS AND WIRING

- Note
1. MR-JE-40B to MR-JE-100B have a built-in regenerative resistor. (factory-wired) When using the regenerative option, refer to section 11.2.
 2. For the encoder cable, use of the option cable is recommended. For cable selection, refer to "HG-KN_/HG-SN_ Servo Motor Instruction Manual".
 3. This diagram shows sink I/O interface. For source I/O interface, refer to section 3.8.3.
 4. For connection of servo motor power wires, refer to "HG-KN_/HG-SN_ Servo Motor Instruction Manual".
 5. Configure the power supply circuit that turns off the magnetic contactor after an alarm occurs on the controller side. To assign ALM (Malfunction) to a pin of the CN3 connector, set [Pr. PD08] or [Pr. PD09] to "_ _ 0 3".
 6. Configure a circuit to turn off EM2 when the power is turned off to prevent an unexpected restart of the servo amplifier.
 7. Connecting a servo motor of the wrong axis to U, V, W, or CN2 of the servo amplifier may cause a malfunction.
 8. Use a magnetic contactor with an operation delay time (interval since a current is applied to the coil until the contact closes) of 80 ms or shorter. Depending on the power supply voltage and operation pattern, bus voltage can decrease. This can shift the mode to the dynamic brake deceleration during forced stop deceleration. When dynamic brake deceleration is not required, slow the time to turn off the magnetic contactor.
 9. The illustration of the 24 V DC power supply is divided between input signal and output signal for convenience. However, they can be configured by one.

3. SIGNALS AND WIRING

(3) Using 3-phase 200 V AC to 240 V AC power supply for MR-JE-200B or MR-JE-300B

- | POINT |
|--|
| <ul style="list-style-type: none"> ● For MR-JE-_B servo amplifiers, the hot line forced stop function is enabled at factory setting. For MR-J4-_B servo amplifiers, the hot line forced stop function is disabled at factory setting. ● If an alarm occurs, the hot line forced stop function outputs hot line forced stop signals to all servo amplifiers before a communication to the controller is cut. Then, the servo amplifiers will be in the [AL. E7.1 Controller forced stop input warning] state, and the servo motors will decelerate to a stop. ● The hot line forced stop function can be disabled with [Pr. PA27]. ● Configure the power supply circuit which turns off magnetic contactors of all servo amplifiers after detection of alarm occurrence on the controller side at alarm occurrence. |

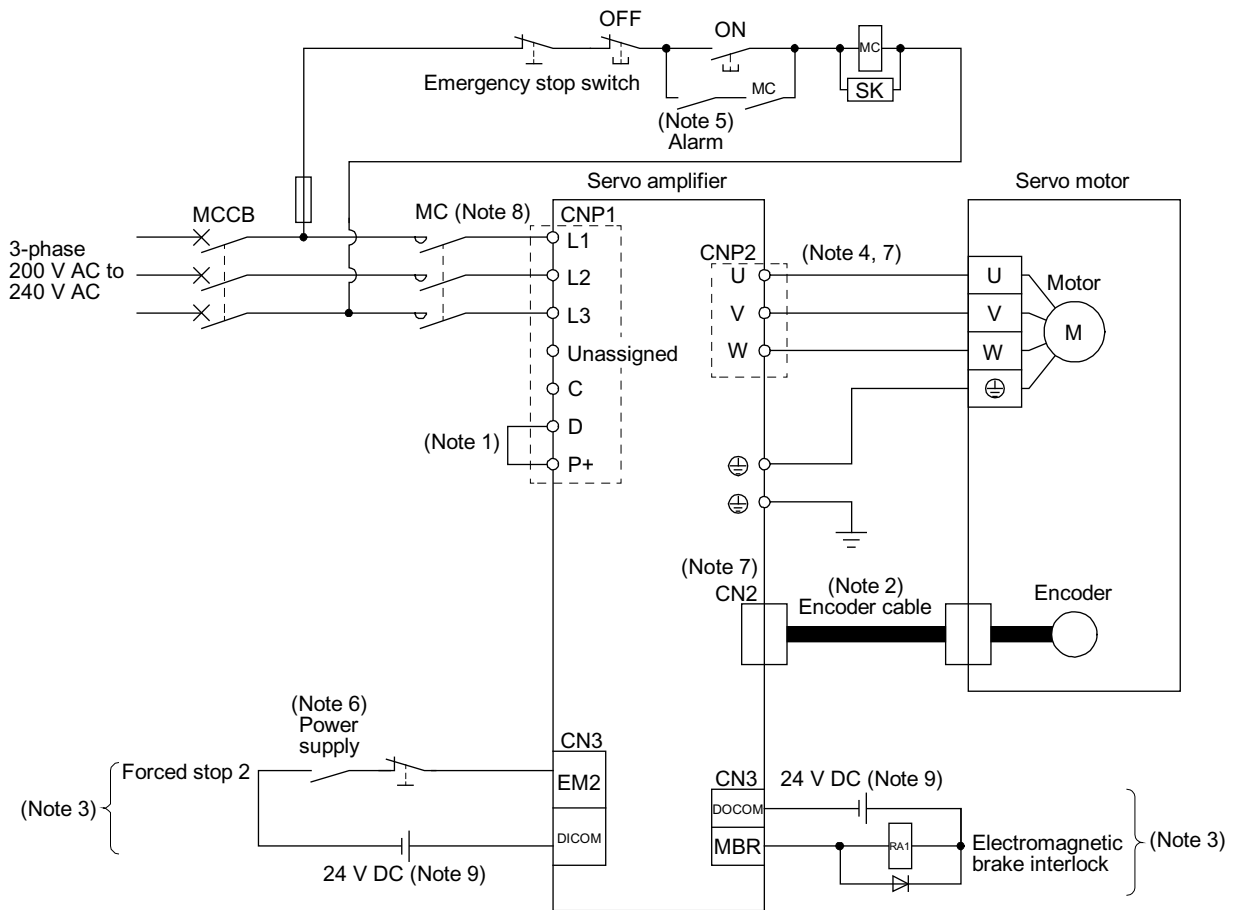

3. SIGNALS AND WIRING

- Note
1. Always connect between P+ and D terminals. (factory-wired) When using the regenerative option, refer to section 11.2.
 2. For the encoder cable, use of the option cable is recommended. For cable selection, refer to "HG-KN_/HG-SN_ Servo Motor Instruction Manual".
 3. This diagram shows sink I/O interface. For source I/O interface, refer to section 3.8.3.
 4. For connection of servo motor power wires, refer to "HG-KN_/HG-SN_ Servo Motor Instruction Manual".
 5. Configure the power supply circuit that turns off the magnetic contactor after an alarm occurs on the controller side. To assign ALM (Malfunction) to a pin of the CN3 connector, set [Pr. PD08] or [Pr. PD09] to "_ _ 0 3".
 6. Configure a circuit to turn off EM2 when the power is turned off to prevent an unexpected restart of the servo amplifier.
 7. Connecting a servo motor of the wrong axis to U, V, W, or CN2 of the servo amplifier may cause a malfunction.
 8. Use a magnetic contactor with an operation delay time (interval since a current is applied to the coil until the contact closes) of 80 ms or shorter. Depending on the power supply voltage and operation pattern, bus voltage can decrease. This can shift the mode to the dynamic brake deceleration during forced stop deceleration. When dynamic brake deceleration is not required, slow the time to turn off the magnetic contactor.
 9. The illustration of the 24 V DC power supply is divided between input signal and output signal for convenience. However, they can be configured by one.

3. SIGNALS AND WIRING

(4) Using 1-phase 200 V AC to 240 V AC power supply for MR-JE-200B

POINT
<ul style="list-style-type: none"> ● For MR-JE-_B servo amplifiers, the hot line forced stop function is enabled at factory setting. For MR-J4-_B servo amplifiers, the hot line forced stop function is disabled at factory setting. ● If an alarm occurs, the hot line forced stop function outputs hot line forced stop signals to all servo amplifiers before a communication to the controller is cut. Then, the servo amplifiers will be in the [AL. E7.1 Controller forced stop input warning] state, and the servo motors will decelerate to a stop. ● The hot line forced stop function can be disabled with [Pr. PA27]. ● Configure the power supply circuit which turns off magnetic contactors of all servo amplifiers after detection of alarm occurrence on the controller side at alarm occurrence. ● Connect the 1-phase 200 V AC to 240 V AC power supply to L1 and L2. One of the connecting destinations is different from MR-JE-100B or less Servo Amplifier's. ● You can use the neutral point of a 3-phase 400 V AC class power supply to input a 1-phase 200 V AC class power supply to the servo amplifier. Refer to app. 10 for details.

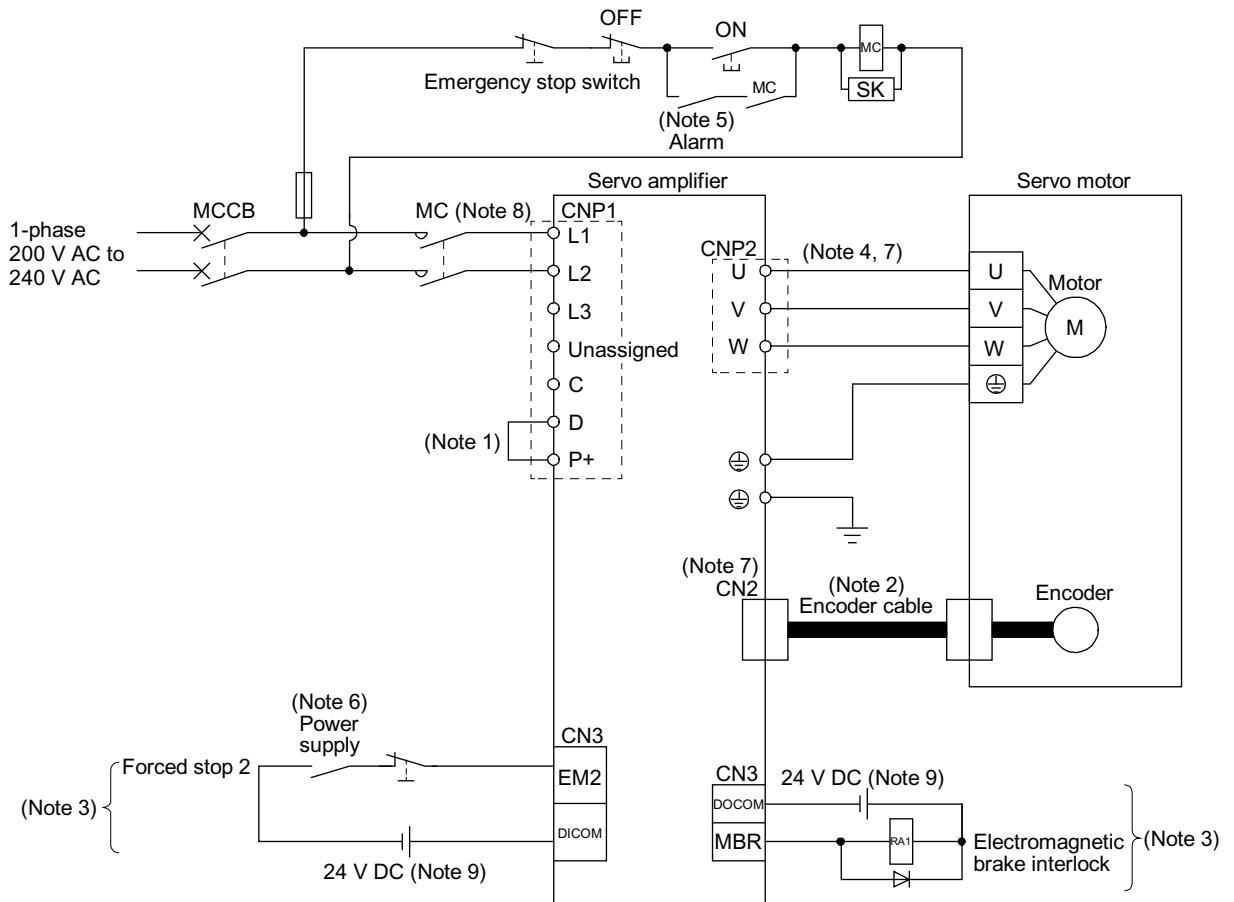

3. SIGNALS AND WIRING

- Note
1. Always connect between P+ and D terminals. (factory-wired) When using the regenerative option, refer to section 11.2.
 2. For the encoder cable, use of the option cable is recommended. For cable selection, refer to "HG-KN_/HG-SN_ Servo Motor Instruction Manual".
 3. This diagram shows sink I/O interface. For source I/O interface, refer to section 3.8.3.
 4. For connection of servo motor power wires, refer to "HG-KN_/HG-SN_ Servo Motor Instruction Manual".
 5. Configure the power supply circuit that turns off the magnetic contactor after an alarm occurs on the controller side. To assign ALM (Malfunction) to a pin of the CN3 connector, set [Pr. PD08] or [Pr. PD09] to "_ _ 0 3".
 6. Configure a circuit to turn off EM2 when the power is turned off to prevent an unexpected restart of the servo amplifier.
 7. Connecting a servo motor of the wrong axis to U, V, W, or CN2 of the servo amplifier may cause a malfunction.
 8. Use a magnetic contactor with an operation delay time (interval since a current is applied to the coil until the contact closes) of 80 ms or shorter. Depending on the power supply voltage and operation pattern, bus voltage can decrease. This can shift the mode to the dynamic brake deceleration during forced stop deceleration. When dynamic brake deceleration is not required, slow the time to turn off the magnetic contactor.
 9. The illustration of the 24 V DC power supply is divided between input signal and output signal for convenience. However, they can be configured by one.

3. SIGNALS AND WIRING

3.2 I/O signal connection example

POINT
●EM2 has the same function as EM1 in the torque control mode.

3.2.1 For sink I/O interface

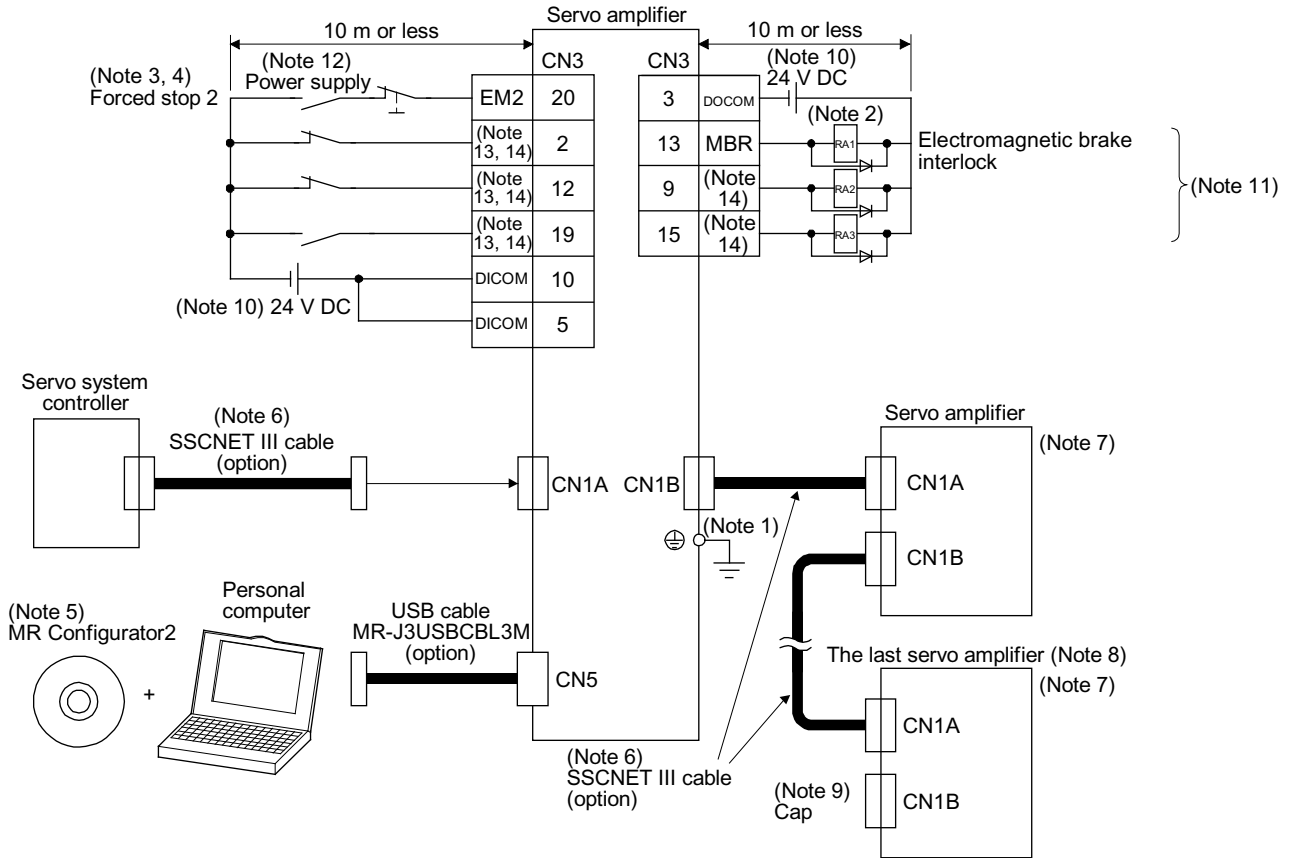

3. SIGNALS AND WIRING

- Note
1. To prevent an electric shock, always connect the protective earth (PE) terminal (marked with ⊕) of the servo amplifier to the protective earth (PE) of the cabinet.
 2. Connect the diode in the correct direction. If it is connected reversely, the servo amplifier will malfunction and will not output signals, disabling EM2 (Forced stop 2) and other protective circuits.
 3. If the controller does not have a forced stop function, always install the forced stop 2 switch (normally closed contact).
 4. When starting operation, always turn on EM2 (Forced stop 2). (normally closed contact)
 5. Use SW1DNC-MRC2-_. (Refer to section 11.4.)
 6. Use SSCNET III cables listed in the following table.

Cable	Cable model	Cable length
Standard cord inside cabinet	MR-J3BUS_M	0.15 m to 3 m
Standard cable outside cabinet	MR-J3BUS_M-A	5 m to 20 m
Long distance cable	MR-J3BUS_M-B	30 m to 50 m

7. The wiring after the second servo amplifier is omitted.
8. Up to 16 axes of servo amplifiers can be connected. The number of connectable axes depends on the controller you use. Refer to section 4.3.1 for setting of axis selection.
9. Make sure to cap the unused CN1B connector.
10. Supply 24 V DC \pm 10% to interfaces from outside. The total current capacity of these power supplies must be 300 mA or lower. For the servo amplifiers manufactured in April 2016 or earlier (or manufactured in China in May 2016 or earlier), the total current capacity must be 100 mA or lower. The current capacity 300 mA is applicable when all I/O signals are used. The current capacity can be decreased by reducing the number of I/O points. Refer to section 3.8.2 that gives the current value necessary for the interface. The illustration of the 24 V DC power supply is divided between input signal and output signal for convenience. However, they can be configured by one.
11. You can change devices of CN3-13, CN3-9, and CN3-15 pins with [Pr. PD07], [Pr. PD08], and [Pr. PD09]. No device is assigned to CN3-9 and CN3-15 pins by default. Set [Pr. PD08] or [Pr. PD09] to "_ _ 0 3", and assign ALM (Malfunction) to a pin of the CN3 connector.
12. Configure a circuit to turn off EM2 when the power is turned off to prevent an unexpected restart of the servo amplifier.
13. You can change devices of CN3-2, CN3-12, and CN3-19 pins with [Pr. PD03], [Pr. PD04], and [Pr. PD05]. When using external input signals (FLS, RLS, and DOG) of the servo amplifier with a controller, assign devices to CN3-2, CN3-12, and CN3-19 pins. No device is assigned to these pins by default. For devices that can be assigned, refer to the controller instruction manual.
14. The CN3-2, CN3-9, CN3-12, CN3-15, and CN3-19 pins are available with servo amplifiers having software version C5 or later, and manufactured in May 2016 or later. For the servo amplifiers manufactured in China, these pins have been available from the June 2016 production. Use MR Configurator2 with software version 1.60N or later.

3. SIGNALS AND WIRING

3.2.2 For source I/O interface

POINT
● For notes, refer to section 3.2.1.

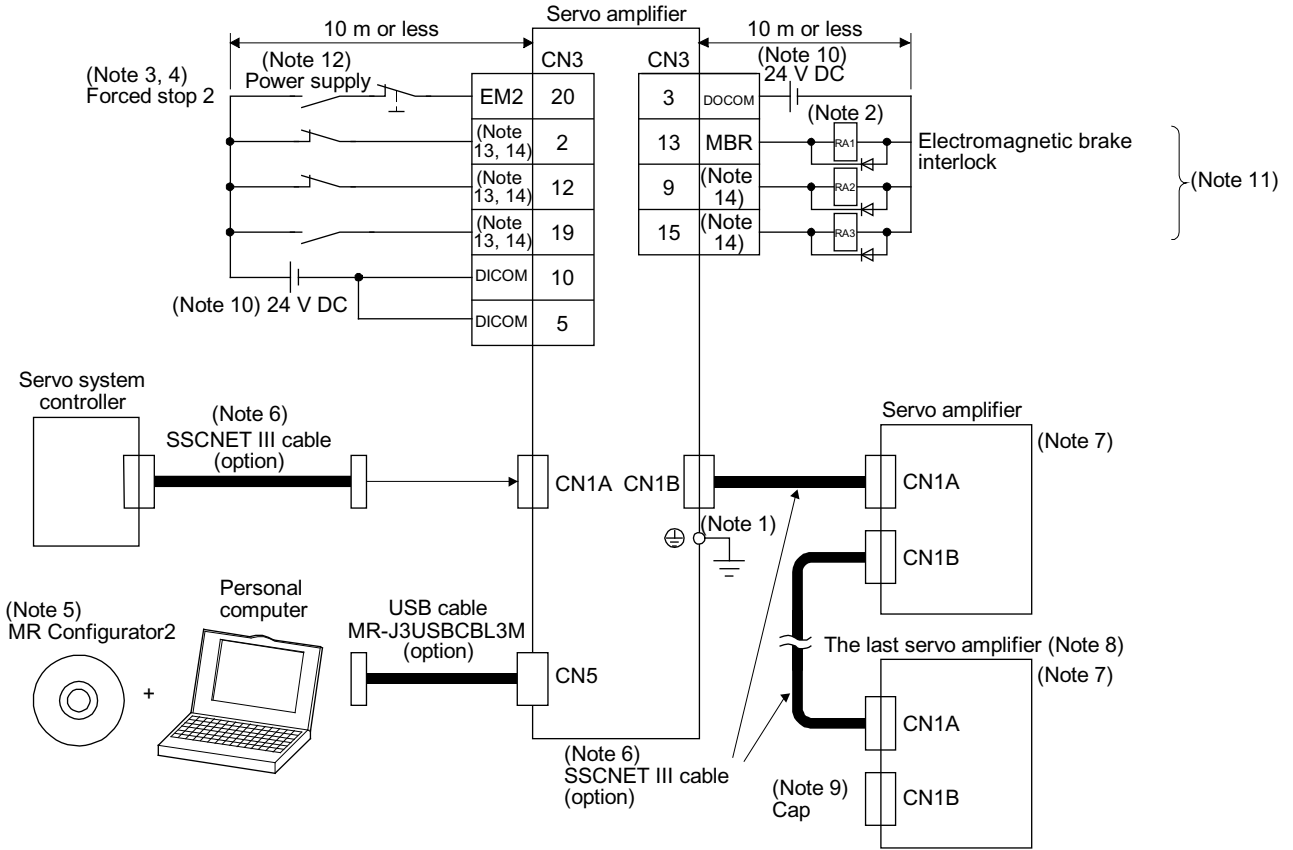

3. SIGNALS AND WIRING

3.3 Explanation of power supply system

3.3.1 Signal explanations

POINT
<p>● For the layout of the connector and terminal block, refer to chapter 9 DIMENSIONS.</p>

Symbol	Connection destination (application)	Description																
L1/L2/L3	Power supply	<p>Supply the following power to L1, L2, and L3. For 1-phase 200 V AC to 240 V AC of MR-JE-10B to MR-JE-100B, connect the power supply to L1 and L3. Leave L2 open. For 1-phase 200 V AC to 240 V AC of MR-JE-200B, connect the power supply to L1 and L2. Leave L3 open.</p> <table border="1" style="margin-left: 20px;"> <thead> <tr> <th style="text-align: center;">Servo amplifier</th> <th style="text-align: center;">MR-JE-10B to MR-JE-100B</th> <th style="text-align: center;">MR-JE-200B</th> <th style="text-align: center;">MR-JE-300B</th> </tr> </thead> <tbody> <tr> <td style="text-align: center;">Power supply</td> <td></td> <td></td> <td></td> </tr> <tr> <td style="text-align: center;">3-phase 200 V AC to 240 V AC, 50 Hz/60 Hz</td> <td colspan="3" style="text-align: center;">L1/L2/L3</td> </tr> <tr> <td style="text-align: center;">1-phase 200 V AC to 240 V AC, 50 Hz/60 Hz</td> <td style="text-align: center;">L1/L3</td> <td style="text-align: center;">L1/L2</td> <td style="text-align: center;"></td> </tr> </tbody> </table>	Servo amplifier	MR-JE-10B to MR-JE-100B	MR-JE-200B	MR-JE-300B	Power supply				3-phase 200 V AC to 240 V AC, 50 Hz/60 Hz	L1/L2/L3			1-phase 200 V AC to 240 V AC, 50 Hz/60 Hz	L1/L3	L1/L2	
Servo amplifier	MR-JE-10B to MR-JE-100B	MR-JE-200B	MR-JE-300B															
Power supply																		
3-phase 200 V AC to 240 V AC, 50 Hz/60 Hz	L1/L2/L3																	
1-phase 200 V AC to 240 V AC, 50 Hz/60 Hz	L1/L3	L1/L2																
P+/C/D	Regenerative option	<p>1) MR-JE-100B or less MR-JE-10B to MR-JE-100B do not have D. When using a servo amplifier built-in regenerative resistor, connect it to P+ and C. (factory-wired) MR-JE-10B and MR-JE-20B do not have a built-in regenerative resistor. When using a regenerative option, disconnect wires of the built-in regenerative resistor from P+ and C. Then, connect wires of the regenerative option to P+ and C.</p> <p>2) MR-JE-200B or more When using a servo amplifier built-in regenerative resistor, connect P+ and D. (factory-wired) When using a regenerative option, disconnect P+ and D, and connect the regenerative option to P+ and C.</p> <p>Refer to section 11.2 for details.</p>																
U/V/W	Servo motor power output	Connect the terminals to the servo motor power supply terminals (U/V/W). Connect the servo amplifier power output (U/V/W) to the servo motor power input (U/V/W) directly. Do not let a magnetic contactor, etc. intervene. Otherwise, it may cause a malfunction.																
N-		<p>This terminal is for manufacturer adjustment. Leave this terminal open. MR-JE-10B to MR-JE-100B do not have N- terminal. MR-JE-200B and MR-JE-300B servo amplifiers without the N- terminal will be available sequentially from the December 2016 production.</p>																
⊕	Protective earth (PE)	Connect this terminal to the grounding terminal of the servo motor and to the protective earth (PE) of the cabinet for grounding.																

3. SIGNALS AND WIRING

3.3.2 Power-on sequence

POINT
●The output signal, etc. may be unstable at power-on.

(1) Power-on procedure

- (a) Always use a magnetic contactor for the power supply wiring (L1/L2/L3) as shown in above section 3.1. Configure the power supply circuit that turns off the magnetic contactor after an alarm occurs on the controller side.
- (b) The servo amplifier receives the servo-on command within 3 s to 4 s after the power supply is switched on.
(Refer to (2) in this section.)

(2) Timing chart

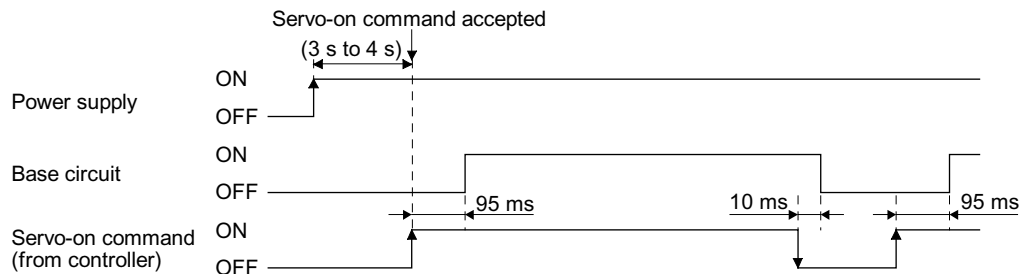

3. SIGNALS AND WIRING

3.3.3 Wiring CNP1 and CNP2

POINT
● For the wire sizes used for wiring, refer to section 11.6.
● When wiring, remove the power connectors from the servo amplifier.
● Insert only one wire or ferrule to each wire insertion hole.

For the wiring to CNP1 and CNP2, use servo amplifier power connectors packed with the amplifier or optional connectors (refer to section 11.1.1).

(1) Connector

(a) MR-JE-10B to MR-JE-100B

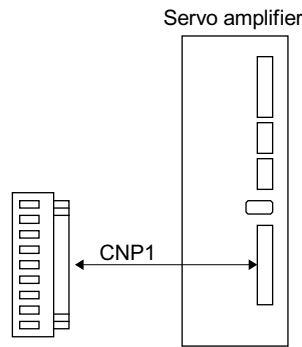

Table 3.1 Connector and applicable wire

Connector	Receptacle assembly	Applicable wire		Stripped length [mm]	Open tool	Manufacturer
		Size	Insulator OD			
CNP1	09JFAT-SAXGDK-H5.0	AWG 18 to 14	3.9 mm or shorter	9	J-FAT-OT (N) or J-FAT-OT	JST

(b) MR-JE-200B/MR-JE-300B

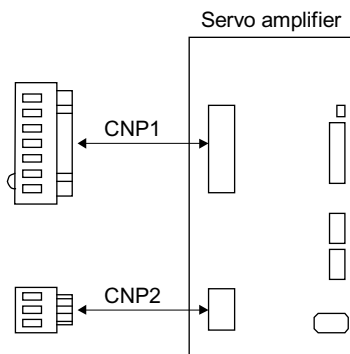

Table 3.2 Connector and applicable wire

Connector	Receptacle assembly	Applicable wire		Stripped length [mm]	Open tool	Manufacturer
		Size	Insulator OD			
CNP1	06(7-4)JFAT-SAXGFK-XL	AWG 16 to 10	4.7 mm or shorter	11.5	J-FAT-OT-EXL	JST
CNP2	03JFAT-SAXGFK-XL					

3. SIGNALS AND WIRING

(2) Cable connection procedure

(a) Fabrication on cable insulator

Refer to table 3.1 and 3.2 for stripped length of the cable insulator. The appropriate stripped length of cables depends on their type, etc. Set the length considering their status.

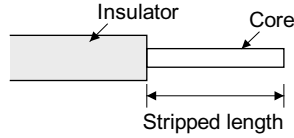

Twist strands lightly and straighten them as follows.

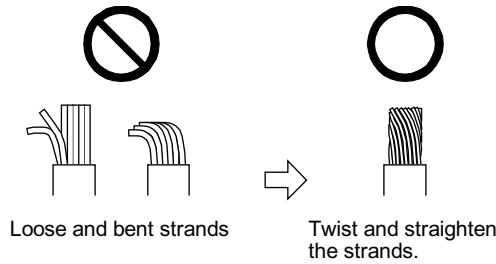

You can also use a ferrule for connection with the connectors. When using a ferrule, select a ferrule and crimping tool listed in the table below.

Servo amplifier	Wire size	Ferrule model (Phoenix Contact)		Crimp terminal (Phoenix Contact)
		For one	For two	
MR-JE-10B to MR-JE-100B	AWG 16	AI1.5-10BK	AI-TWIN2 × 1.5-10BK	CRIMPFOX-ZA3
	AWG 14	AI2.5-10BU		
MR-JE-200B to MR-JE-300B	AWG 16	AI1.5-10BK	AI-TWIN2 × 1.5-10BK	
	AWG 14	AI2.5-10BU	AI-TWIN2 × 2.5-10BU	
	AWG 12	AI4-10GY		

(b) Inserting wire

Insert only one wire or ferrule to each wire insertion hole.

Insert the open tool as follows and push it down to open the spring. While the open tool is pushed down, insert the stripped wire into the wire insertion hole. Check the wire insertion depth, and make sure that the cable insulator will not be caught by the spring and that the conductive part of the stripped wire will not be exposed.

Release the open tool to fix the wire. Pull the wire lightly to confirm that the wire is surely connected.

In addition, make sure that no conductor wire sticks out of the connector.

The following shows a connection example of the CNP2 connector for 2 kW and 3 kW.

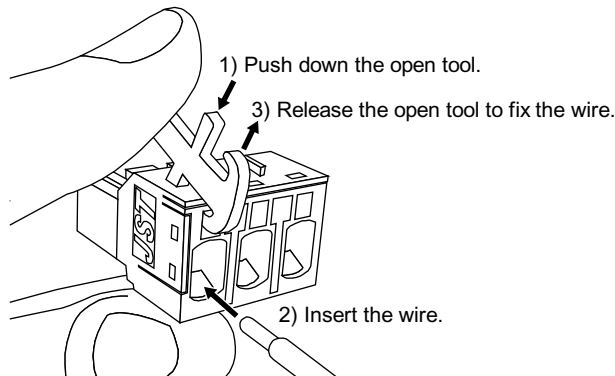

3. SIGNALS AND WIRING

3.4 Connectors and pin assignment

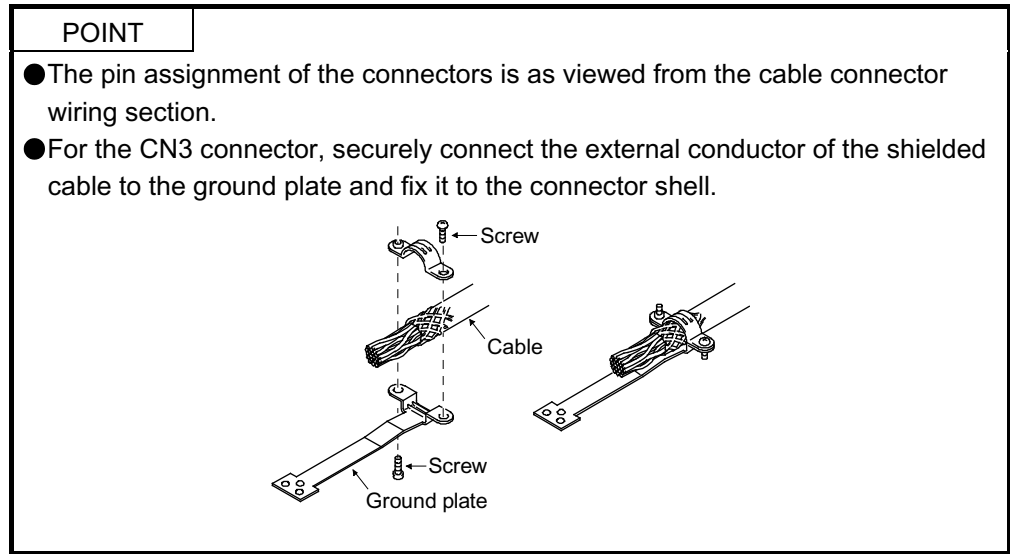

The servo amplifier front view shown is that of the MR-JE-40B or less. Refer to chapter 9 DIMENSIONS for the appearances and connector layouts of the other servo amplifiers.

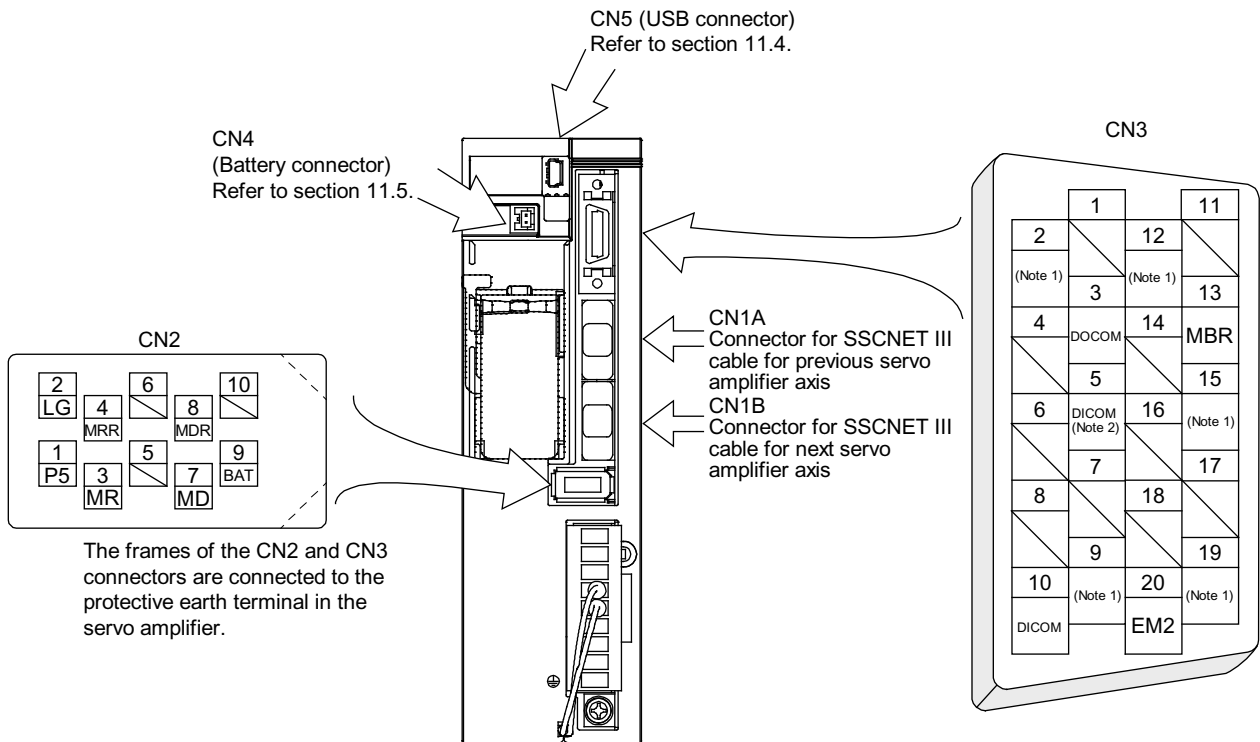

- Note 1. No device is assigned to these pins by default. You can assign any input device to CN3-2, CN3-12, and CN3-19 pins with [Pr. PD03] to [Pr. PD05]. Also, you can assign any output device to CN3-9 and CN3-15 pins with [Pr. PD08] and [Pr. PD09]. These pins are available with servo amplifiers having software version C5 or later, and manufactured in May 2016 or later. For the servo amplifiers manufactured in China, these pins have been available from the June 2016 production.
- Note 2. The CN3-5 pin is available with servo amplifiers having software version C5 or later, and manufactured in May 2016 or later. For the servo amplifiers manufactured in China, these pins have been available from the June 2016 production.

3. SIGNALS AND WIRING

3.5 Signal (device) explanations

For the I/O interfaces (symbols in I/O division column in the table), refer to section 3.8.2.

The pin numbers in the connector pin number column are those in the initial status.

3.5.1 Input device

(1) Input device pin

The following shows the input device pins and parameters for setting devices.

Connector pin No.	Parameter	Initial device	I/O division
CN3-2 (Note)	[Pr. PD03]	Not assigned (always off)	DI-1
CN3-12 (Note)	[Pr. PD04]	Not assigned (always off)	
CN3-19 (Note)	[Pr. PD05]	Not assigned (always off)	

Note. When using external input signals (FLS, RLS, and DOG) of the servo amplifier with a controller, assign devices to CN3-2, CN3-12, and CN3-19 pins. The CN3-2, CN3-12, and CN3-19 pins are available with servo amplifiers having software version C5 or later, and manufactured in May 2016 or later. For the servo amplifiers manufactured in China, these pins have been available from the June 2016 production.

(2) Input device explanations

Device	Symbol	Connector pin number	Function and application	I/O division																		
Forced stop 2	EM2	CN3-20	Turn off EM2 (open between commons) to decelerate the servo motor to a stop with commands. Turn EM2 on (short between commons) in the forced stop state to reset that state. Set [Pr. PA04] to "2 1 _ _" to disable EM2. The following shows the setting of [Pr. PA04].	DI-1																		
			<table border="1"> <thead> <tr> <th rowspan="2">[Pr. PA04] setting</th> <th rowspan="2">EM2/EM1</th> <th colspan="2">Deceleration method</th> </tr> <tr> <th>EM2 or EM1 is off</th> <th>Alarm occurred</th> </tr> </thead> <tbody> <tr> <td>0 0 _ _</td> <td>EM1</td> <td>MBR (Electromagnetic brake interlock) turns off without the forced stop deceleration.</td> <td>MBR (Electromagnetic brake interlock) turns off without the forced stop deceleration.</td> </tr> <tr> <td>2 0 _ _</td> <td>EM2</td> <td>MBR (Electromagnetic brake interlock) turns off after the forced stop deceleration.</td> <td>MBR (Electromagnetic brake interlock) turns off after the forced stop deceleration.</td> </tr> <tr> <td>0 1 _ _</td> <td>Not using EM2 and EM1</td> <td style="text-align: center;">/</td> <td>MBR (Electromagnetic brake interlock) turns off without the forced stop deceleration.</td> </tr> <tr> <td>2 1 _ _</td> <td>Not using EM2 and EM1</td> <td style="text-align: center;">/</td> <td>MBR (Electromagnetic brake interlock) turns off after the forced stop deceleration.</td> </tr> </tbody> </table>		[Pr. PA04] setting	EM2/EM1	Deceleration method		EM2 or EM1 is off	Alarm occurred	0 0 _ _	EM1	MBR (Electromagnetic brake interlock) turns off without the forced stop deceleration.	MBR (Electromagnetic brake interlock) turns off without the forced stop deceleration.	2 0 _ _	EM2	MBR (Electromagnetic brake interlock) turns off after the forced stop deceleration.	MBR (Electromagnetic brake interlock) turns off after the forced stop deceleration.	0 1 _ _	Not using EM2 and EM1	/	MBR (Electromagnetic brake interlock) turns off without the forced stop deceleration.
[Pr. PA04] setting	EM2/EM1	Deceleration method																				
		EM2 or EM1 is off	Alarm occurred																			
0 0 _ _	EM1	MBR (Electromagnetic brake interlock) turns off without the forced stop deceleration.	MBR (Electromagnetic brake interlock) turns off without the forced stop deceleration.																			
2 0 _ _	EM2	MBR (Electromagnetic brake interlock) turns off after the forced stop deceleration.	MBR (Electromagnetic brake interlock) turns off after the forced stop deceleration.																			
0 1 _ _	Not using EM2 and EM1	/	MBR (Electromagnetic brake interlock) turns off without the forced stop deceleration.																			
2 1 _ _	Not using EM2 and EM1	/	MBR (Electromagnetic brake interlock) turns off after the forced stop deceleration.																			
Forced stop 1	EM1	(CN3-20)	EM2 and EM1 are mutually exclusive. Note that EM2 has the same function as EM1 in the torque control mode. When using EM1, set [Pr. PA04] to "0 0 _ _" to enable EM1. When EM1 is turned off (open between commons), the base circuit shuts off, and the dynamic brake operates to decelerate the servo motor to a stop. The forced stop will be reset when EM1 is turned on (short between commons). Set [Pr. PA04] to "0 1 _ _" to disable EM1.	DI-1																		

3. SIGNALS AND WIRING

3.5.2 Output device

(1) Output device pin

The following shows the output device pins and parameters for assigning devices.

Connector pin No.	Parameter	Initial device	I/O division
CN3-13	[Pr. PD07]	MBR	DO-1
CN3-9 (Note)	[Pr. PD08]	Not assigned (always off)	
CN3-15 (Note)	[Pr. PD09]	Not assigned (always off)	

Note. The CN3-9 and CN3-15 pins are available with servo amplifiers having software version C5 or later, and manufactured in May 2016 or later. For the servo amplifiers manufactured in China, these pins have been available from the June 2016 production.

(2) Output device explanations

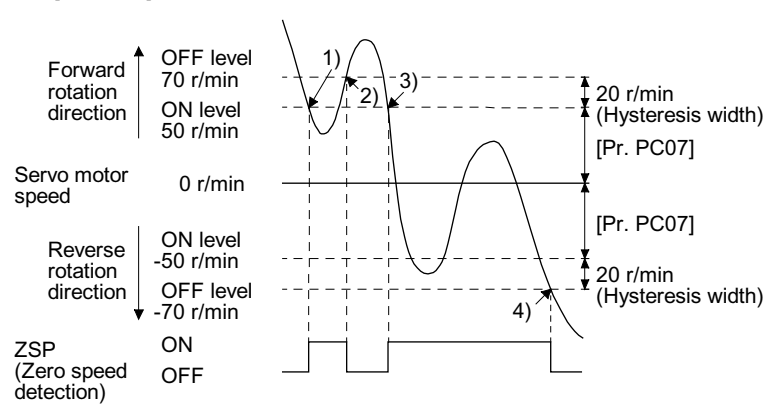
Device	Symbol	Function and application
Electromagnetic brake interlock	MBR	When using the device, set operation delay time of the electromagnetic brake in [Pr. PC02]. When a servo-off status or alarm occurs, MBR will turn off.
Malfunction	ALM	When the protective circuit is activated to shut off the base circuit, ALM will turn off. When an alarm does not occur, ALM will turn on after 2.5 s to 3.5 s after power-on.
In-position	INP	When the number of droop pulses is in the in-position range, INP will turn on. The in-position range can be changed using [Pr. PA10]. When the in-position range is increased, INP may be on during low-speed rotation. The device cannot be used in the speed control mode, torque control mode, or continuous operation to torque control mode.
Ready	RD	Enabling servo-on to make the servo amplifier ready to operate will turn on RD.
Speed reached	SA	SA will turn off during servo-off. When the servo motor speed reaches the following range, SA will turn on. Preset speed \pm ((Preset speed \times 0.05) + 20) r/min When the preset speed is 20 r/min or slower, SA always turns on. The device cannot be used in the position control mode and torque control mode.
Limiting speed	VLC	When the speed reaches the speed limit value in the torque control mode, VLC will turn on. When the servo is off, TLC will be turned off. The device cannot be used in the position control mode and speed control mode.
Zero speed detection	ZSP	ZSP turns on when the servo motor speed is zero speed (50 r/min) or slower. Zero speed can be changed with [Pr. PC07].  <p>Forward rotation direction OFF level 70 r/min ON level 50 r/min</p> <p>Servo motor speed 0 r/min</p> <p>Reverse rotation direction ON level -50 r/min OFF level -70 r/min</p> <p>ZSP (Zero speed detection) ON OFF</p> <p>20 r/min (Hysteresis width) [Pr. PC07]</p> <p>20 r/min (Hysteresis width) [Pr. PC07]</p> <p>1) 2) 3) 4)</p> <p>ZSP will turn on when the servo motor is decelerated to 50 r/min (at 1)), and will turn off when the servo motor is accelerated to 70 r/min again (at 2)). ZSP will turn on when the servo motor is decelerated again to 50 r/min (at 3)), and will turn off when the servo motor speed has reached -70 r/min (at 4)). The range from the point when the servo motor speed has reached on level, and ZSP turns on, to the point when it is accelerated again and has reached off level is called hysteresis width. Hysteresis width is 20 r/min for this servo amplifier.</p>

3. SIGNALS AND WIRING

Device	Symbol	Function and application
Limiting torque	TLC	When the torque reaches the torque limit value during torque generation, TLC will turn on. When the servo is off, TLC will be turned off. This device cannot be used in the torque control mode.
Warning	WNG	When a warning has occurred, WNG turns on. When a warning is not occurring, WNG will turn off in 2.5 s to 3.5 s after power-on.
Battery warning	BWNG	BWNG turns on when [AL. 92 Battery cable disconnection warning] or [AL. 9F Battery warning] has occurred. When the battery warning is not occurring, BWNG will turn off in 2.5 s to 3.5 s after power-on.
Variable gain selection	CDPS	CDPS will turn on during variable gain.
Absolute position undetermined	ABSV	ABSV turns on when the absolute position is undetermined. The device cannot be used in the speed control mode and torque control mode.
During tough drive	MTTR	When a tough drive is "Enabled" in [Pr. PA20], activating the instantaneous power failure tough drive will turn on MTTR.

3.5.3 Power supply

Signal name	Symbol	Connector pin number	Function and application
Digital I/F power supply input	DICOM	CN3-5 CN3-10	Input 24 V DC (24 V DC \pm 10% 300 mA) (Note) for I/O interface. The power supply capacity changes depending on the number of I/O interface points to be used. For sink interface, connect + of 24 V DC external power supply. For source interface, connect - of 24 V DC external power supply.
Digital I/F common	DOCOM	CN3-3	Common terminal of input signal such as EM2 of the servo amplifier. This terminal is separated from LG. For sink interface, connect - of 24 V DC external power supply. For source interface, connect + of 24 V DC external power supply.
Shield	SD	Plate	Connect the external conductor of the shielded wire.

Note. For the servo amplifiers manufactured in April 2016 or earlier (or manufactured in China in May 2016 or earlier), the value 100 mA is applicable.

3. SIGNALS AND WIRING

3.6 Forced stop deceleration function

POINT
●When alarms not related to the forced stop function occur, control of motor deceleration cannot be guaranteed. (Refer to chapter 8.)
●When SSCNET III/H communication shut-off occurs, forced stop deceleration will operate. (Refer to section 3.7.1 (3).)
●In the torque control mode, the forced stop deceleration function cannot be used.
●Disable the forced stop deceleration function for a machine in which multiple axes are connected together, such as a tandem structure. If an alarm occurs with the forced stop deceleration function disabled, the servo motor will stop with the dynamic brake.

3.6.1 Forced stop deceleration function

When EM2 is turned off, dynamic brake will start to stop the servo motor after forced stop deceleration. During this sequence, the display shows [AL. E6 Servo forced stop warning].

During normal operation, do not use EM2 (Forced stop 2) to alternate stop and drive. The servo amplifier life may be shortened.

(1) Connection diagram

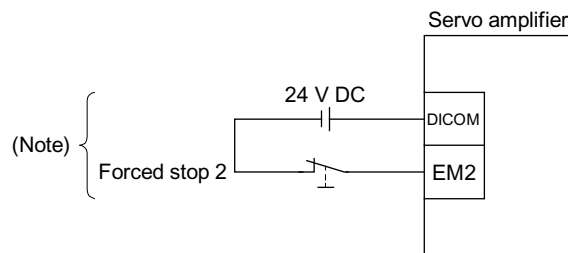

Note. This diagram shows sink I/O interface. For source I/O interface, refer to section 3.8.3.

3. SIGNALS AND WIRING

(2) Timing chart

When EM2 (Forced stop 2) turns off, the motor will decelerate according to [Pr. PC24 Forced stop deceleration time constant]. Once the motor speed is below [Pr. PC07 Zero speed] after completion of the deceleration command, base power is cut and the dynamic brake activates.

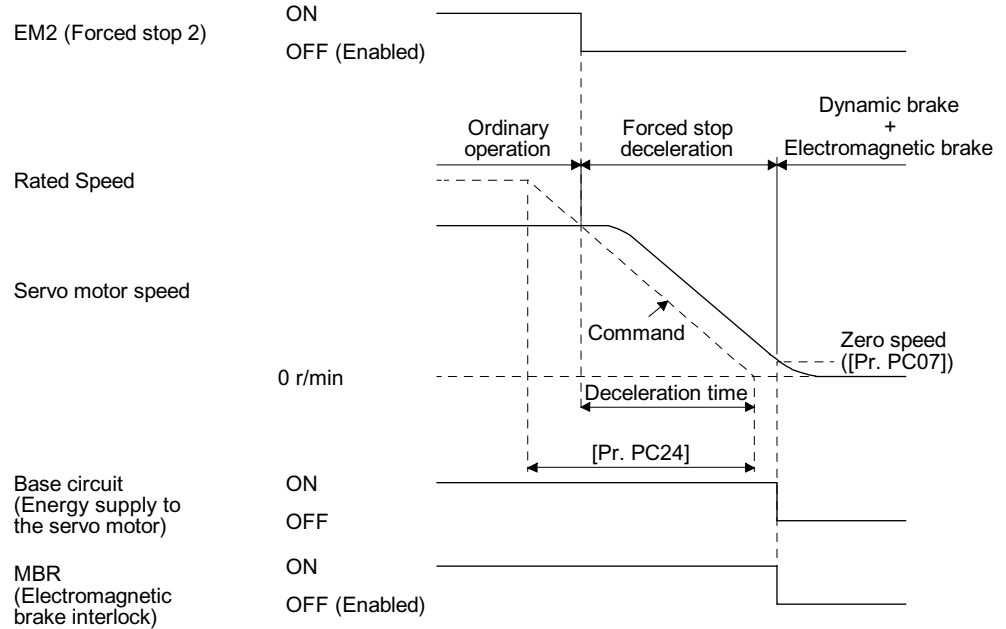

3.6.2 Base circuit shut-off delay time function

The base circuit shut-off delay time function is used to prevent a vertical axis from dropping at a forced stop (EM2 goes off), alarm occurrence, or SSCNET III/H communication shut-off due to delay time of the electromagnetic brake. Set the time from MBR (Electromagnetic brake interlock) off to base circuit shut-off with [Pr. PC02].

(1) Timing chart

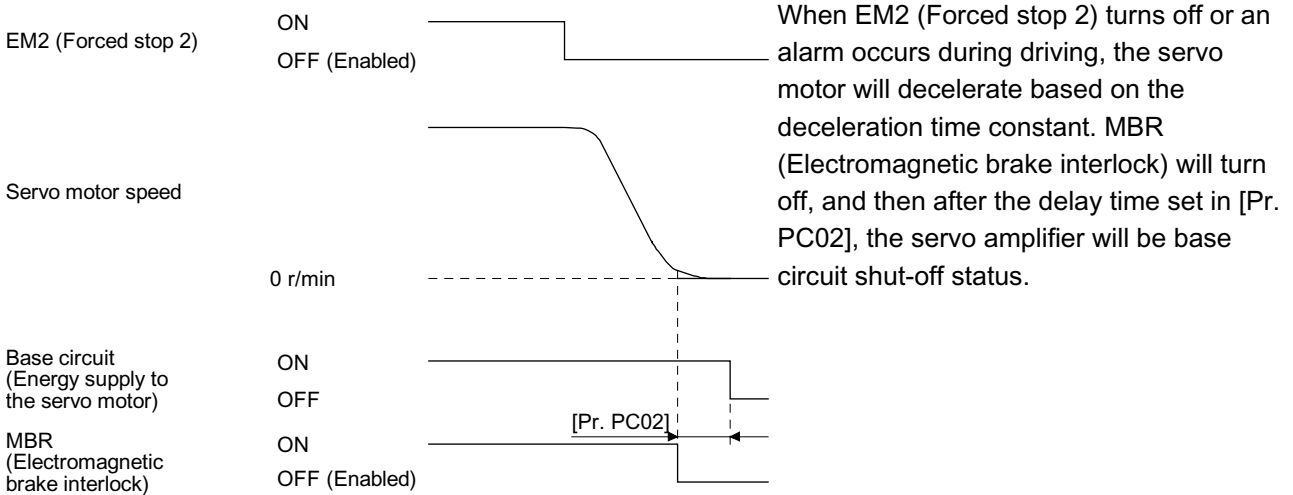

3. SIGNALS AND WIRING

(2) Adjustment

While the servo motor is stopped, turn off EM2 (Forced stop 2), adjust the base circuit shut-off delay time in [Pr. PC02], and set the value to approximately 1.5 times of the smallest delay time in which the servo motor shaft does not freefall.

3.6.3 Vertical axis freefall prevention function

The vertical axis freefall prevention function prevents machine damage by pulling up the shaft slightly like the following case.

When the servo motor is used for operating vertical axis, the servo motor electromagnetic brake and the base circuit shut-off delay time function prevent dropping axis at forced stop. However, the functions may not prevent dropping axis a few μm due to the backlash of the servo motor electromagnetic brake.

The vertical axis freefall prevention function is enabled with the following conditions.

- Other than "0" is set to [Pr. PC31 Vertical axis freefall prevention compensation amount].
- EM2 (Forced stop 2) turns off, an alarm occurs, or SSCNET III/H communication shut-off occurs while the servo motor speed is zero speed or slower.
- The base circuit shut-off delay time function is enabled.

(1) Timing chart

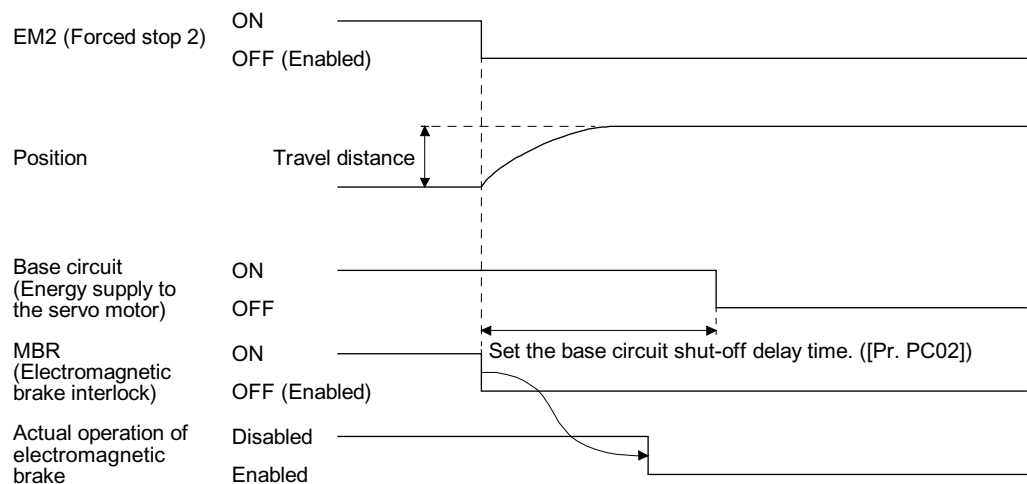

(2) Adjustment

- Set the freefall prevention compensation amount in [Pr. PC31].
- While the servo motor is stopped, turn off the EM2 (Forced stop 2). Adjust the base circuit shut-off delay time in [Pr. PC02] in accordance with the travel distance ([Pr. PC31]). Adjust it considering the freefall prevention compensation amount by checking the servo motor speed, torque ripple, etc.

3.6.4 Residual risks of the forced stop function (EM2)

- (1) The forced stop function is not activated by alarms that activate the dynamic brake when the alarms occur.
- (2) When an alarm that activates the dynamic brake during forced stop deceleration occurs, the braking distance until the servo motor stops will be longer than that of normal forced stop deceleration without the dynamic brake.

3. SIGNALS AND WIRING

3.7 Alarm occurrence timing chart

 CAUTION	<ul style="list-style-type: none"> When an alarm has occurred, remove its cause, make sure that the operation signal is not being input, ensure safety, and reset the alarm before restarting operation.
--	---

POINT	<ul style="list-style-type: none"> In the torque control mode, the forced stop deceleration function cannot be used.
--------------	---

To deactivate the alarm, cycle the power or give the error reset or CPU reset command from the servo system controller. However, the alarm cannot be deactivated unless its cause is removed.

3.7.1 When you use the forced stop deceleration function

POINT	<ul style="list-style-type: none"> To enable the function, set "2 _ _ _ (initial value)" in [Pr. PA04]. Disable the forced stop deceleration function for a machine in which multiple axes are connected together, such as a tandem structure. If an alarm occurs with the forced stop deceleration function disabled, the servo motor will stop with the dynamic brake.
--------------	--

(1) When the forced stop deceleration function is enabled

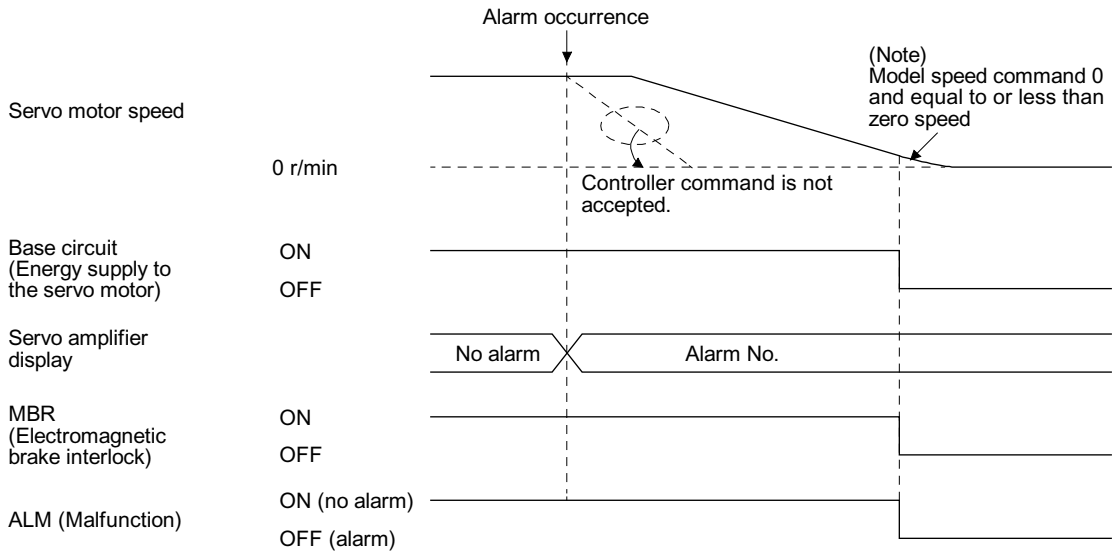

Note. The model speed command is a speed command generated in the servo amplifier for forced stop deceleration of the servo motor.

3. SIGNALS AND WIRING

(2) When the forced stop deceleration function is not enabled

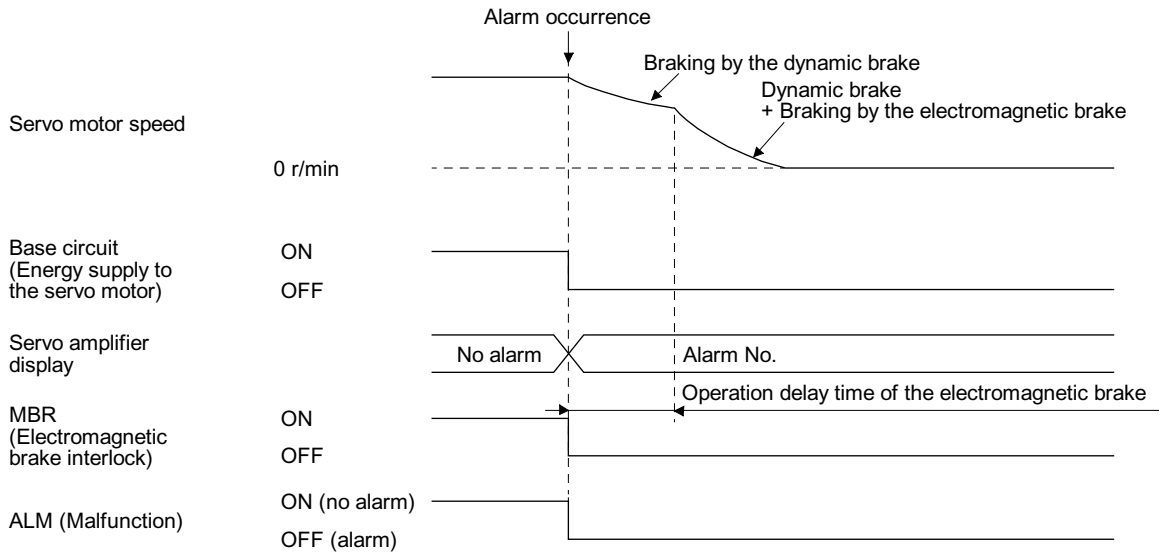

(3) When SSCNET III/H communication shut-off occurs

The dynamic brake may operate depending on the communication shut-off status.

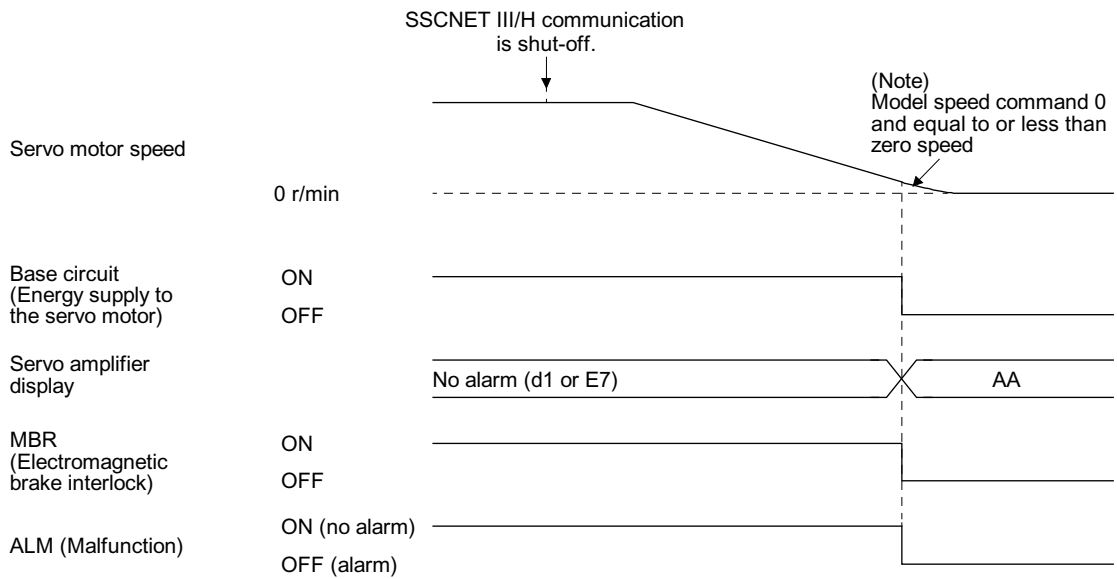

Note. The model speed command is a speed command generated in the servo amplifier for forced stop deceleration of the servo motor.

3.7.2 When you do not use the forced stop deceleration function

POINT
● To disable the function, set "0 _ _ _" in [Pr. PA04].

The timing chart that shows the servo motor condition when an alarm or SSCNET III/H communication shut-off occurs is the same as section 3.7.1 (2).

3. SIGNALS AND WIRING

3.7.3 Hot line forced stop function

POINT
<ul style="list-style-type: none"> ● When the power supply of the servo amplifier is shut off during deceleration to a stop by a hot line forced stop signal, the servo motor will be stopped with the dynamic brake. ● For using the hot line forced stop function with MR-JE-_B servo amplifier and MR-J4-_B servo amplifier together, refer to app. 8 for the hot line forced stop function of MR-J4-_B servo amplifiers.

(1) Summary

The hot line forced stop function enables all servo motors to decelerate to a stop safely if an alarm occurs in a system configuration using MR-JE-_B servo amplifiers.

Since the power supply of the MR-JE-_B servo amplifier is commonly used for main circuit and control circuit power supplies, if the power supply is shut off at occurrence of an alarm, servo amplifiers in which the alarm occurred and later cannot communicate with the controller. Thus, if an alarm occurs, the function outputs hot line forced stop signals to all servo amplifiers before a communication to the controller is cut. Then, servo amplifiers will be in the [AL. E7.1 Controller forced stop input warning] state and will be stopped safely. Also, the function can be disabled with a parameter.

(2) Parameter setting

The hot line forced stop function is enabled at factory setting. Setting "_ _ _ 1" in [Pr. PA27] disables the function.

(3) Operation description

If an alarm occurs in the second axis servo amplifier in a 4-axis system configuration, the operation will be as follows.

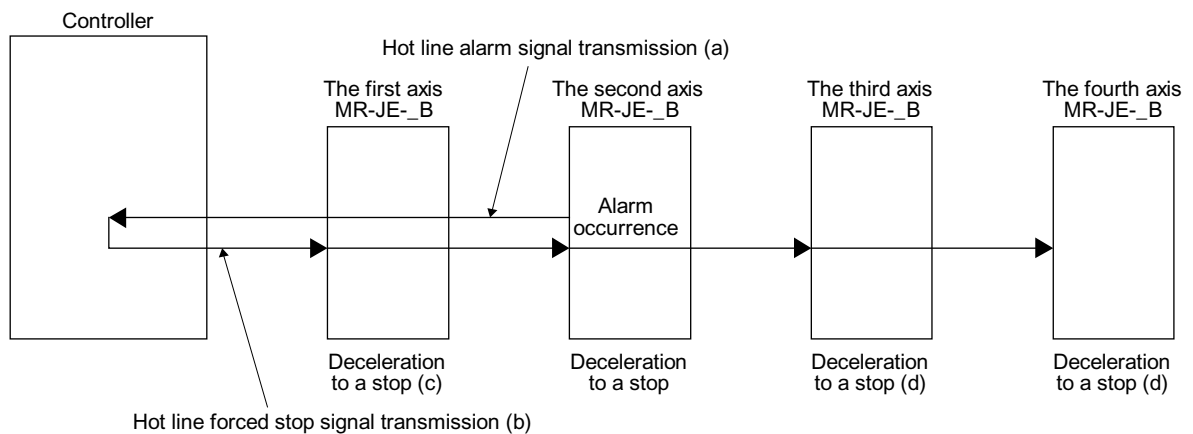

(a) The servo amplifier in which an alarm occurred transmits the hot line alarm signal to the controller.

(b) Upon receipt of a hot line alarm signal, the controller transmits hot line forced stop signals to all servo amplifiers.

(c) Upon receipt of a hot line forced stop signal from the controller, [AL. E7.1 Controller forced stop input warning] will occur in the servo amplifier, and normally operating servo amplifiers will enable the servo motors to decelerate to a stop. "E7.1" will be shown on the display of the servo amplifier.

3. SIGNALS AND WIRING

(d) When the power supply of a servo amplifier in which an alarm occurred is shut off, the servo motors connected to the subsequent servo amplifiers decelerate to a stop, and the servo amplifiers will be in a non-connection state with the controller. "AA" will be shown on the display of the servo amplifier.

(4) Timing chart

(a) When the hot line forced stop function is enabled

- 1) If an alarm that leads to a deceleration to a stop occurs in the second axis servo amplifier, and then the power supply is off
To clear [AL. E7.1 Controller forced stop input warning], give the error reset command from the controller.

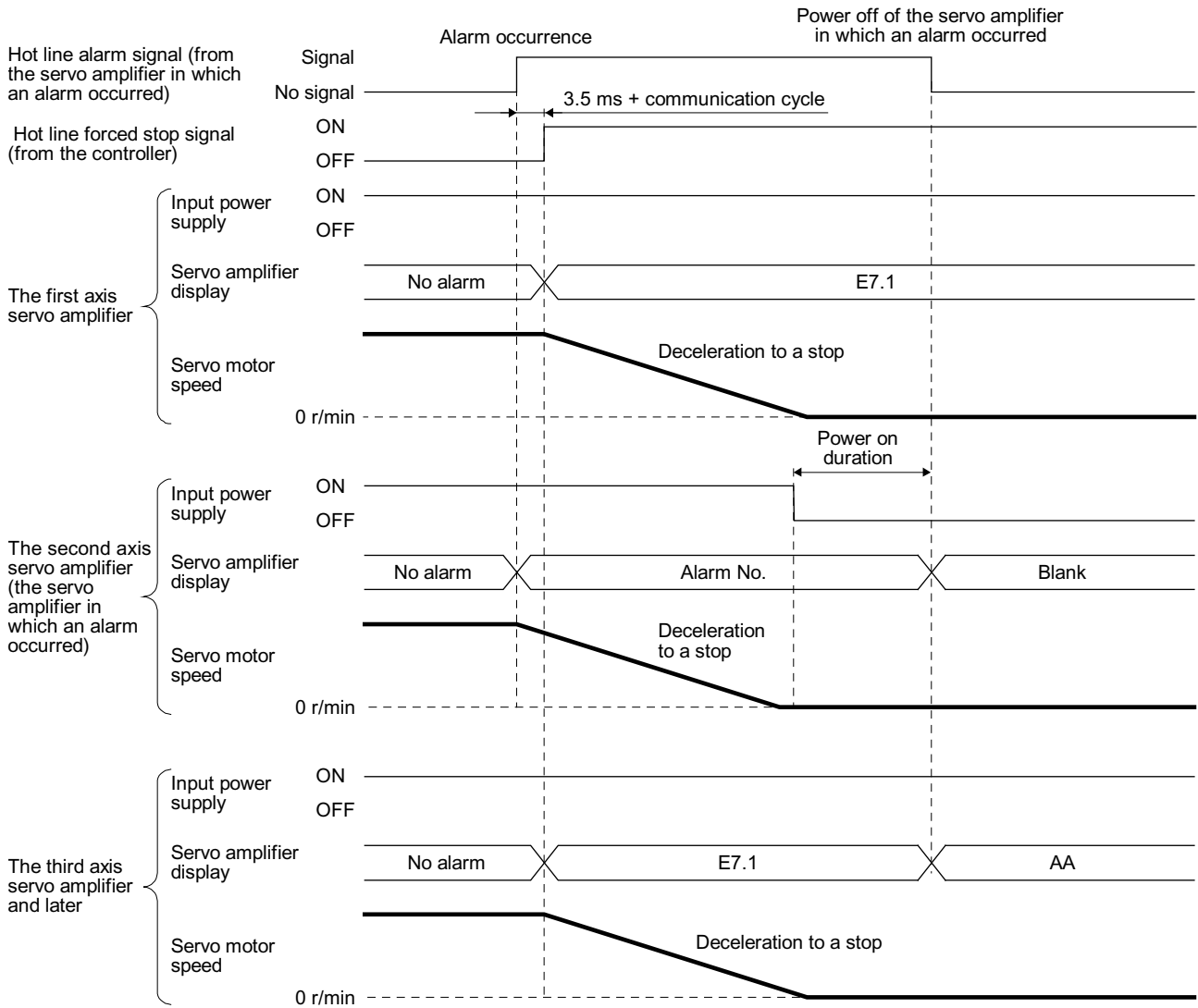

3. SIGNALS AND WIRING

- 2) If an alarm that stops the servo motor with the dynamic brake occurs in the second axis servo amplifier, and then the power supply is off
 To clear [AL. E7.1 Controller forced stop input warning], give the error reset command from the controller.

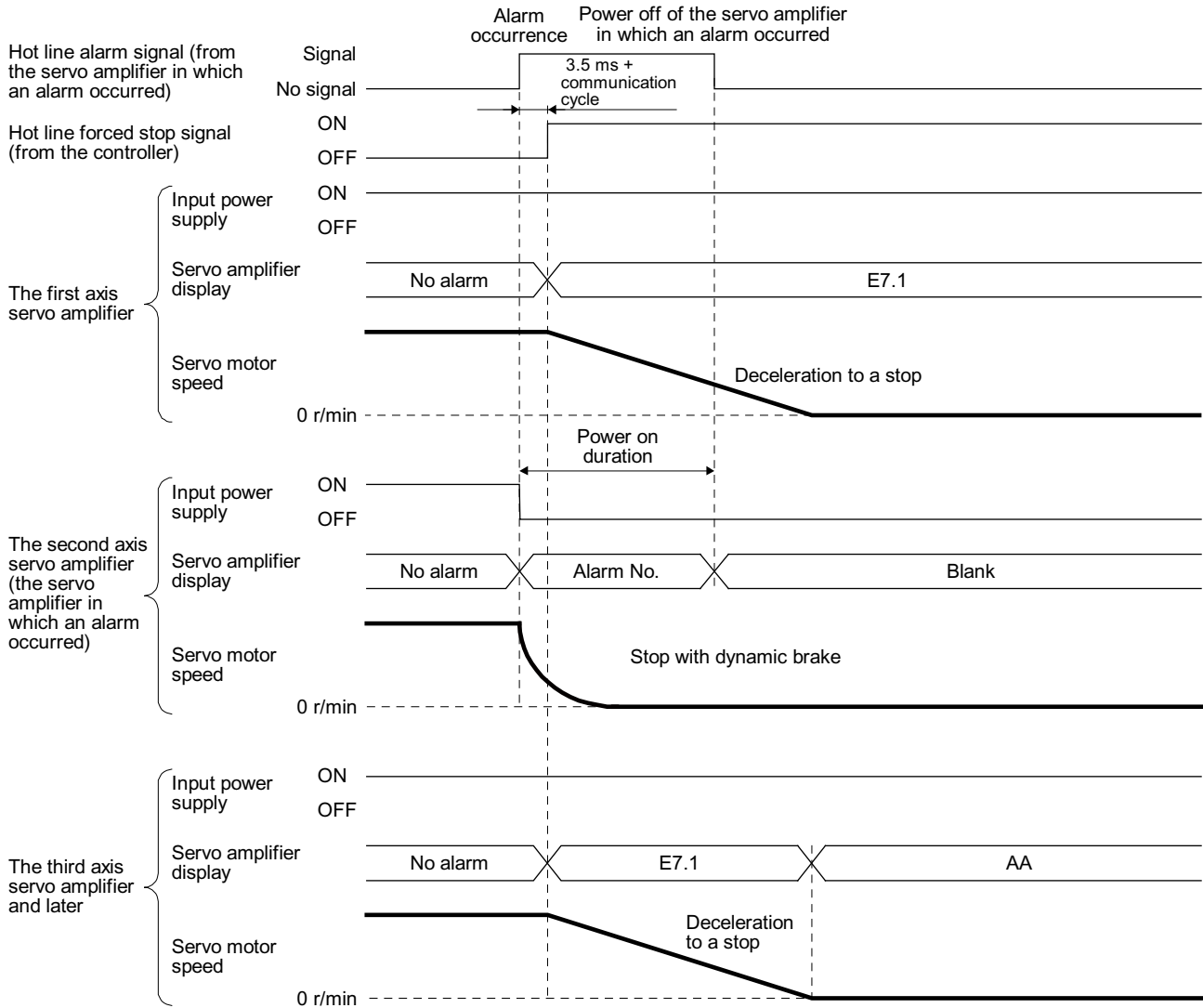

3. SIGNALS AND WIRING

3) When the power of the second axis servo amplifier is turned off

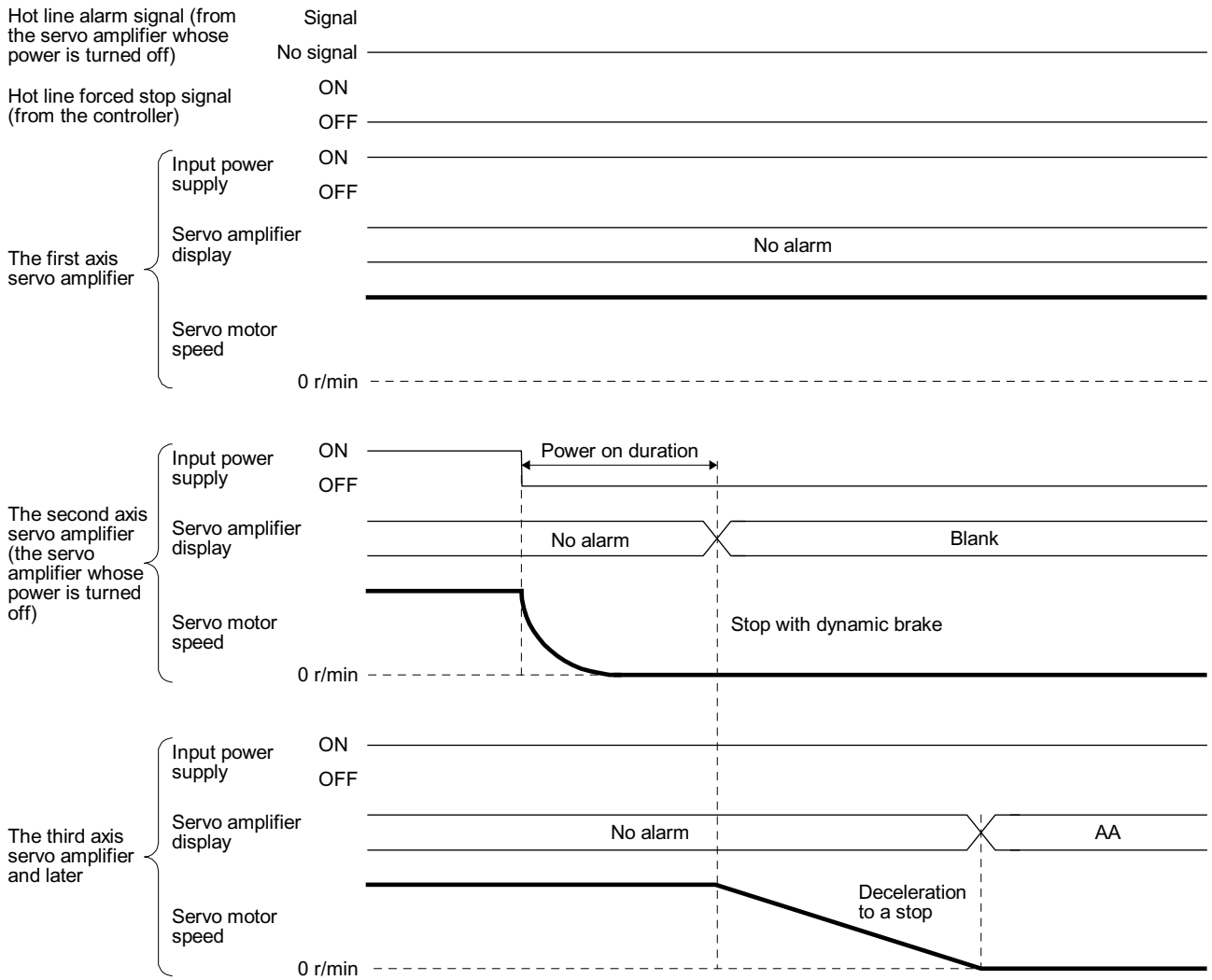

3. SIGNALS AND WIRING

4) When power supplies of all servo amplifiers are turned off

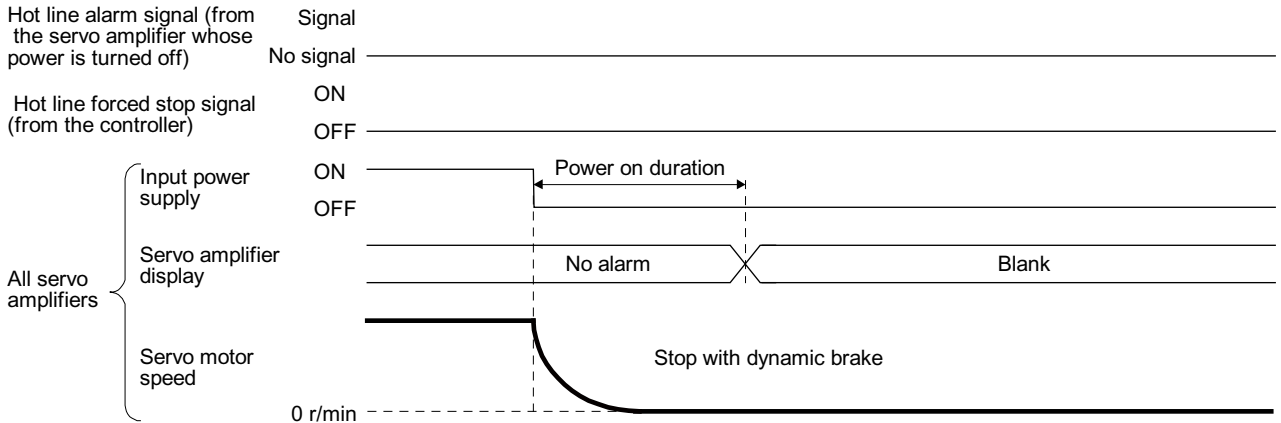

(b) When the hot line forced stop function is disabled

- 1) If an alarm that leads to a deceleration to a stop occurs in the second axis servo amplifier, and then the power supply is off

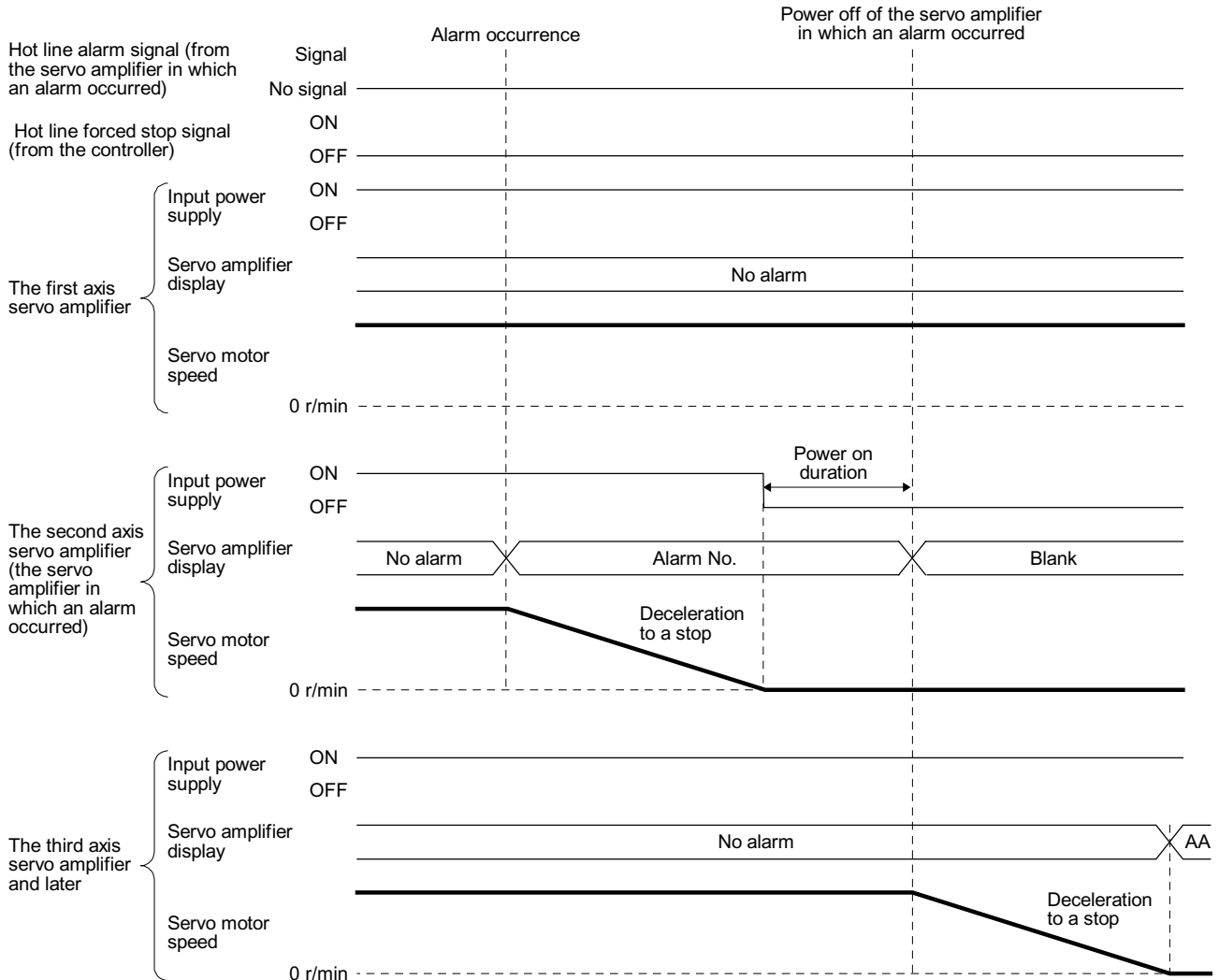

3. SIGNALS AND WIRING

- 2) If an alarm that stops the servo motor with the dynamic brake occurs in the second axis servo amplifier, and then the power supply is off

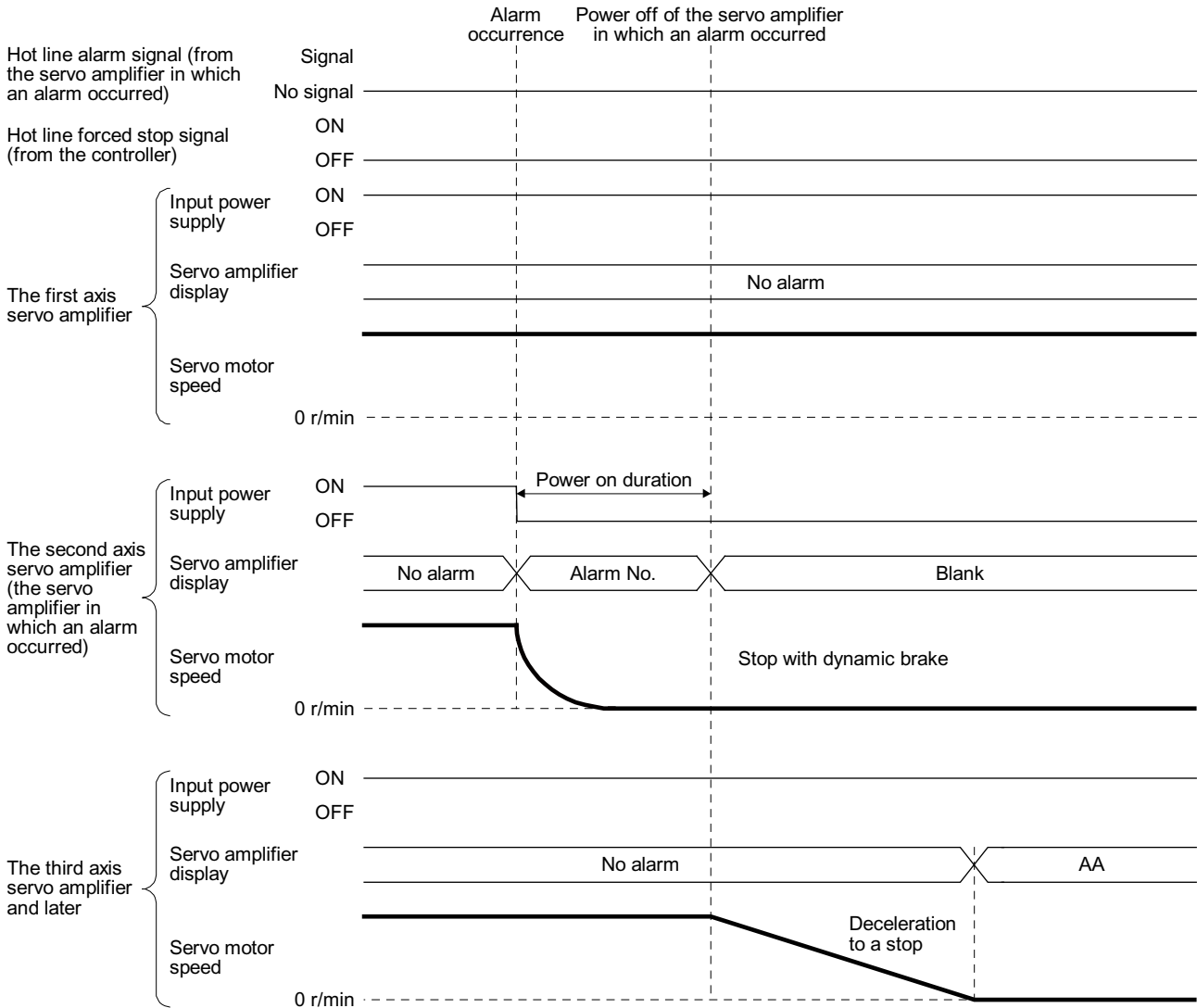

- 3) When the power of the second axis servo amplifier is turned off
It is the same as (4) (a) 3) in this section.
- 4) When power supplies of all servo amplifiers are turned off
It is the same as (4) (a) 4) in this section.

3. SIGNALS AND WIRING

3.8 Interfaces

3.8.1 Internal connection diagram

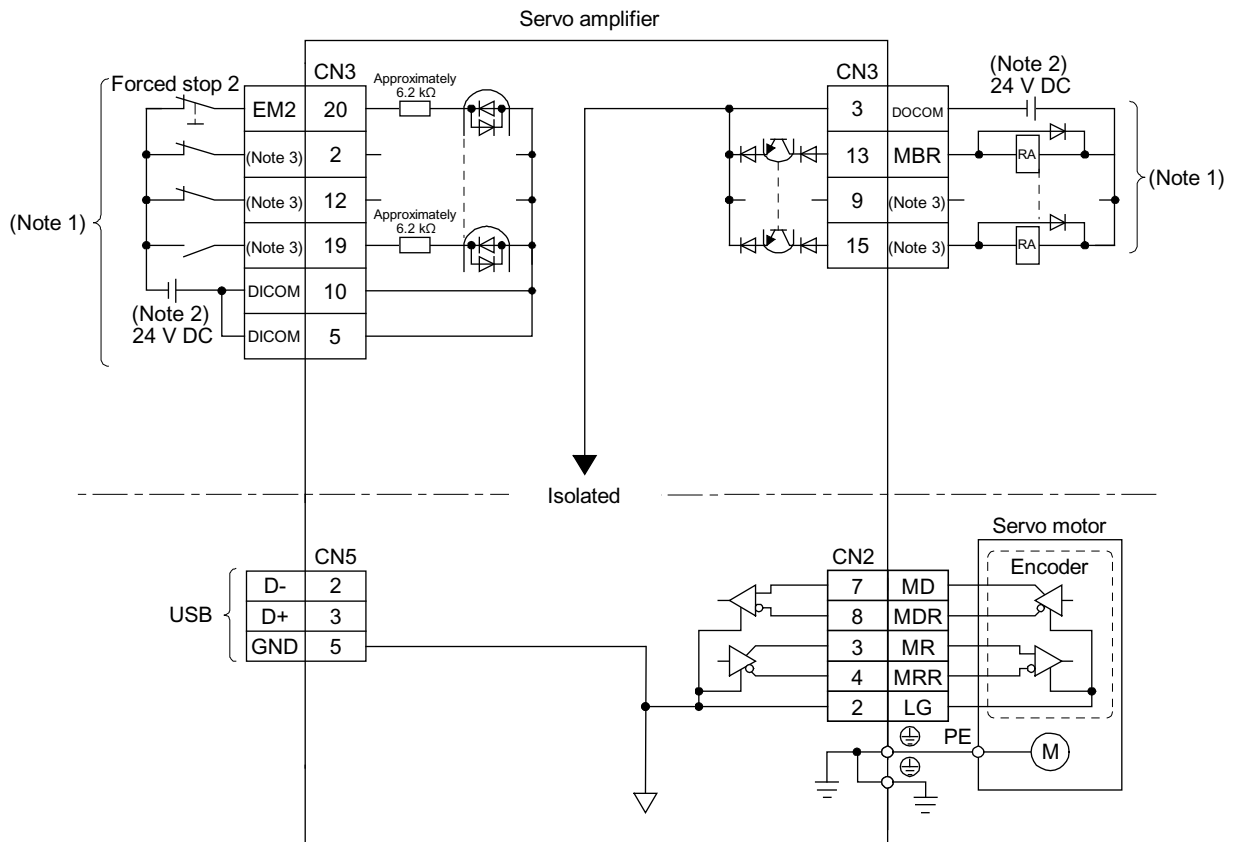

- Note 1. This diagram shows sink I/O interface. For source I/O interface, refer to section 3.8.3.
- Note 2. The illustration of the 24 V DC power supply is divided between input signal and output signal for convenience. However, they can be configured by one.
- Note 3. The CN3-2, CN3-9, CN3-12, CN3-15, and CN3-19 pins are available with servo amplifiers having software version C5 or later, and manufactured in May 2016 or later. For the servo amplifiers manufactured in China, these pins have been available from the June 2016 production.

3. SIGNALS AND WIRING

3.8.2 Detailed explanation of interfaces

This section provides the details of the I/O signal interfaces (refer to the I/O division in the table) given in section 3.5. Refer to this section and make connection with the external device.

(1) Digital input interface DI-1

This is an input circuit whose photocoupler cathode side is the input terminal. Transmit signals from sink (open-collector) type transistor output, relay switch, etc. The following is a connection diagram for sink input. Refer to section 3.8.3 for source input.

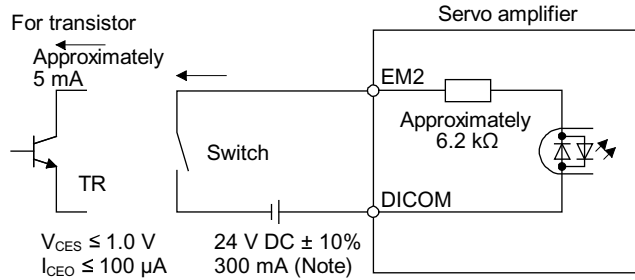

Note. For the servo amplifiers manufactured in April 2016 or earlier (or manufactured in China in May 2016 or earlier), the value 100 mA is applicable.

(2) Digital output interface DO-1

This is a circuit in which the collector of the output transistor is the output terminal. When the output transistor is turned on, the current will flow to the collector terminal.

A lamp, relay, or photocoupler can be driven. Install a diode (D) for an inductive load, or install an inrush current suppressing resistor (R) for a lamp load.

(Rated current: 40 mA or lower, maximum current: 50 mA or lower, inrush current: 100 mA or lower) A maximum of 2.6 V voltage drop occurs in the servo amplifier.

The following shows a connection diagram for sink output. Refer to section 3.8.3 for source output.

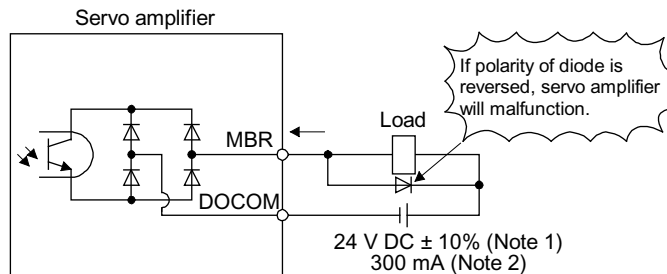

Note 1. If the voltage drop (maximum of 2.6 V) interferes with the relay operation, apply high voltage (maximum of 26.4 V) from an external source.
2. For the servo amplifiers manufactured in April 2016 or earlier (or manufactured in China in May 2016 or earlier), the value 100 mA is applicable.

3. SIGNALS AND WIRING

3.8.3 Source I/O interfaces

In this servo amplifier, source type I/O interfaces can be used.

(1) Digital input interface DI-1

This is an input circuit in which the anode of the photocoupler is the input terminal. Transmit signals from source (open-collector) type transistor output, relay switch, etc.

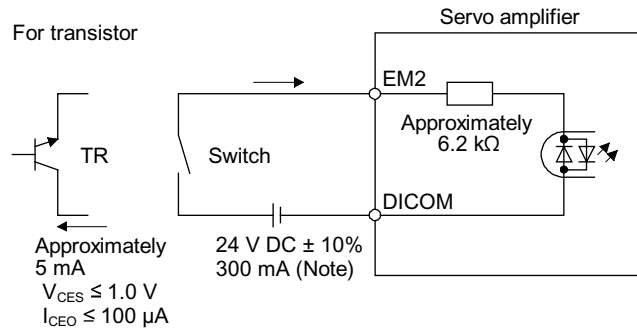

Note. For the servo amplifiers manufactured in April 2016 or earlier (or manufactured in China in May 2016 or earlier), the value 100 mA is applicable.

(2) Digital output interface DO-1

This is a circuit in which the emitter of the output transistor is the output terminal. When the output transistor is turned on, the current will flow from the output terminal to a load.

A maximum of 2.6 V voltage drop occurs in the servo amplifier.

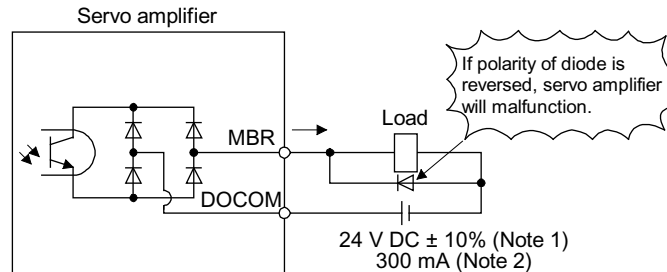

Note 1. If the voltage drop (maximum of 2.6 V) interferes with the relay operation, apply high voltage (maximum of 26.4 V) from an external source.

Note 2. For the servo amplifiers manufactured in April 2016 or earlier (or manufactured in China in May 2016 or earlier), the value 100 mA is applicable.

3. SIGNALS AND WIRING

3.9 SSCNET III cable connection

POINT
● Do not look directly at the light generated from the CN1A/CN1B connector of the servo amplifier or the end of the SSCNET III cable. The light can be a discomfort when it enters the eye.

(1) SSCNET III cable connection

For the CN1A connector, connect the SSCNET III cable connected to a controller in host side or a servo amplifier of the previous axis. For the CN1B connector, connect the SSCNET III cable connected to the servo amplifier of the next axis. For the CN1B connector of the final axis, put a cap came with the servo amplifier.

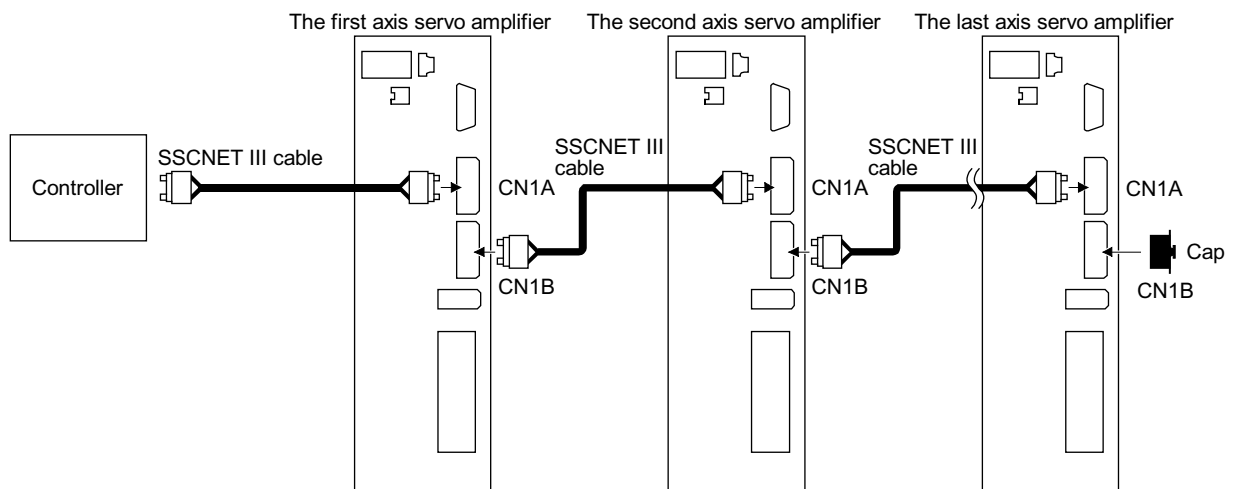

(2) How to connect/disconnect cable

POINT
● The CN1A and CN1B connectors are capped to protect light devices inside the connector from dust. For this reason, do not remove the cap until just before connecting the SSCNET III cable. Then, when removing the SSCNET III cable, make sure to put a cap.
● Keep the cap for the CN1A/CN1B connector and the tube for protecting the optical cord end of an SSCNET III cable in a plastic bag with a slide fastener of the SSCNET III cable to prevent them from becoming dirty.
● When asking repair of the servo amplifier for some malfunctions, make sure to cap the CN1A and CN1B connectors. When the connector is not capped, the light device may be damaged at the transit. In this case, replacing and repairing the light device are required.

3. SIGNALS AND WIRING

(a) Connection

- 1) For an SSCNET III cable in the shipping status, the tube for protecting the optical cord end is put on the end of connector. Remove this tube.
- 2) Remove the CN1A and CN1B connector caps of the servo amplifier.
- 3) While holding a tab of the SSCNET III cable connector, make sure to insert it into the CN1A and CN1B connectors of the servo amplifier until you hear the click. If the end face of the optical cord tip is dirty, optical transmission is interrupted and it may cause malfunctions. If it becomes dirty, wipe with a bonded textile, etc. Do not use solvent such as alcohol.

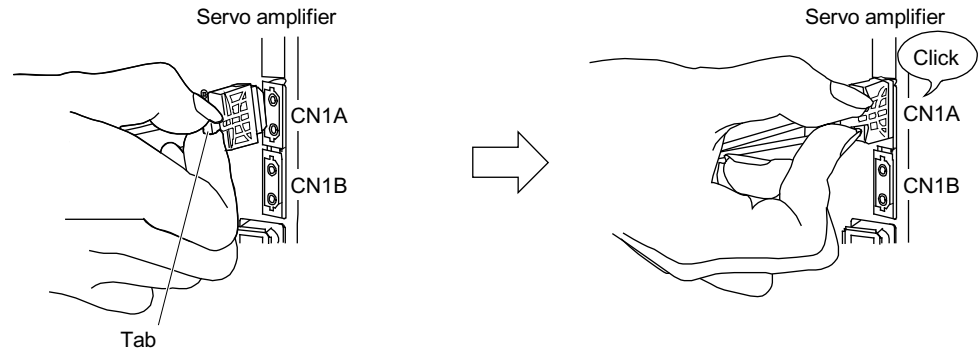

(b) Disconnection

While holding a tab of the SSCNET III cable connector, pull out the connector.

When pulling out the SSCNET III cable from the servo amplifier, be sure to put the cap on the connector parts of the servo amplifier to prevent them from becoming dirty. For the SSCNET III cable, attach the tube for protecting the optical cord's end face on the end of the connector.

3. SIGNALS AND WIRING

3.10 Servo motor with an electromagnetic brake

3.10.1 Safety precautions

- Configure an electromagnetic brake circuit which is interlocked with an external emergency stop switch.

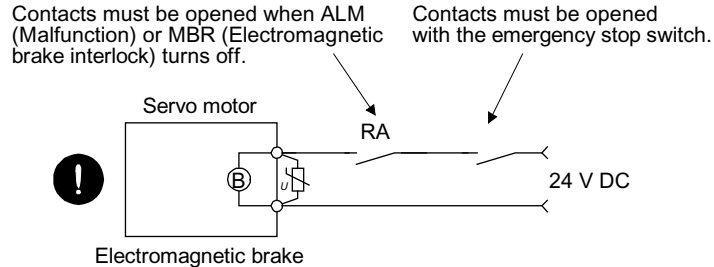

CAUTION

- A failure of MBR (Electromagnetic brake interlock) or ALM (Malfunction) leads to the malfunction of a brake.
- The electromagnetic brake is provided for holding purpose and must not be used for ordinary braking.
- Before operating the servo motor, be sure to confirm that the electromagnetic brake operates properly.
- Do not use the 24 V DC interface power supply for the electromagnetic brake. Always use the power supply designed exclusively for the electromagnetic brake. Otherwise, it may cause a malfunction.
- When using EM2 (Forced stop 2), use MBR (Electromagnetic brake interlock) for operating the electromagnetic brake. Operating the electromagnetic brake without using MBR during deceleration to a stop will saturate servo motor torques at the maximum value due to brake torque of the electromagnetic brake. This can result in delay of the deceleration to a stop from a set value.

POINT

- Refer to "HG-KN_/HG-SN_ Servo Motor Instruction Manual" for specifications such as the power supply capacity and operation delay time of the electromagnetic brake.
- Refer to "HG-KN_/HG-SN_ Servo Motor Instruction Manual" for the selection of a surge absorber for the electromagnetic brake.

Note the following when the servo motor with an electromagnetic brake is used.

- 1) The brake will operate when the power (24 V DC) turns off.
- 2) Turn off the servo-on command after the servo motor stopped.

3. SIGNALS AND WIRING

(1) Connection diagram

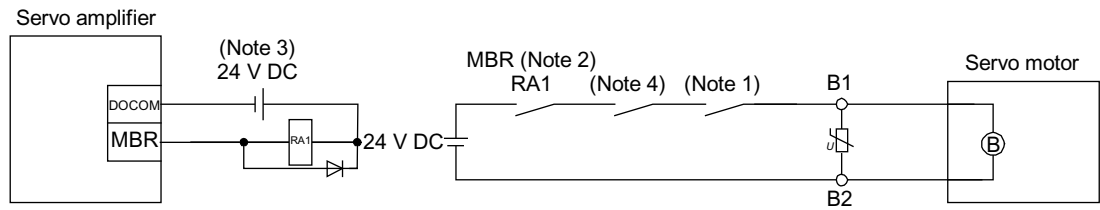

- Note 1. Create the circuit in order to shut off by interlocking with the emergency stop switch.
Note 2. A failure of MBR leads to the malfunction of a brake.
Note 3. Do not use the 24 V DC interface power supply for the electromagnetic brake.
Note 4. Create the circuit in order to shut off by interlocking with an alarm detected by the controller.

(2) Setting

In [Pr. PC02 Electromagnetic brake sequence output], set a delay time (T_b) from MBR (Electromagnetic brake interlock) off to base circuit shut-off at a servo-off as in the timing chart in section 3.10.2.

3. SIGNALS AND WIRING

3.10.2 Timing chart

(1) When you use the forced stop deceleration function

POINT

● To enable the function, set "2 _ _ _ (initial value)" in [Pr. PA04].

(a) Servo-on command (from controller) on/off

When the servo-on command is turned off, the servo lock will be released after T_b [ms], and the servo motor will coast. If the electromagnetic brake is enabled during servo-lock, the brake life may be shorter. Therefore, set T_b about 1.5 times of the minimum delay time where the moving part will not drop down for a vertical axis system, etc.

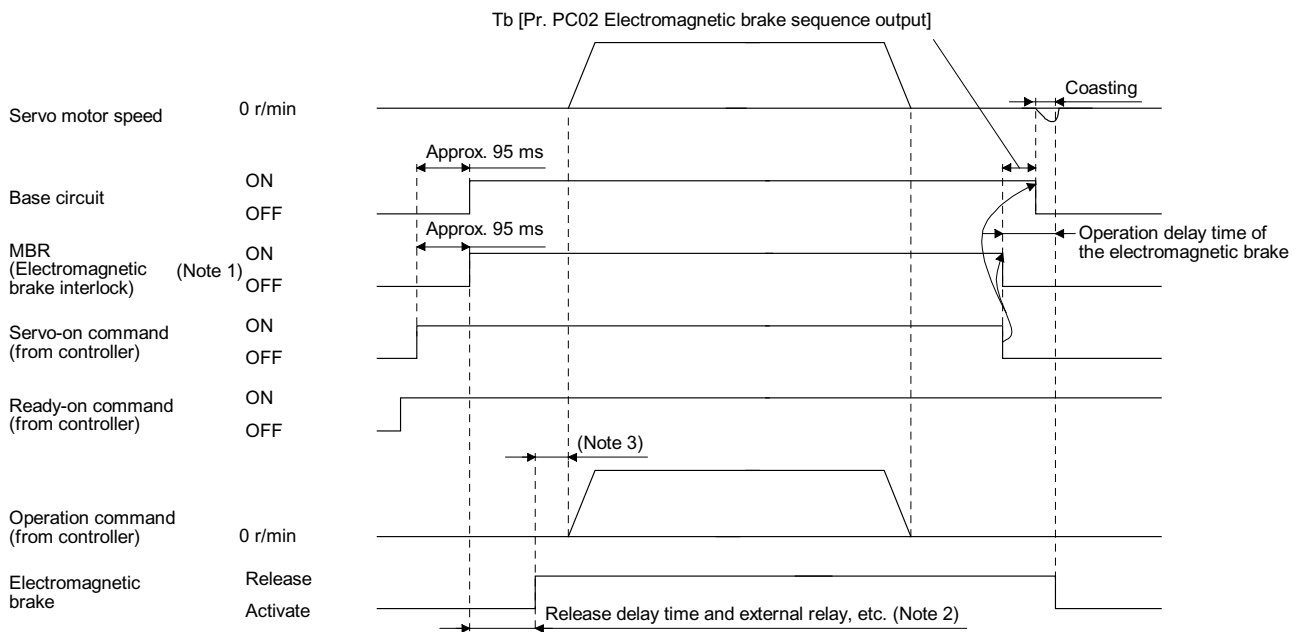

- Note 1. ON: The electromagnetic brake is not activated.
OFF: The electromagnetic brake is activated.
2. The electromagnetic brake is released after the release delay time of the electromagnetic brake and operation time of the external circuit relay, etc. For the release delay time of the electromagnetic brake, refer to "HG-KN/HG-SN Servo Motor Instruction Manual".
3. Give the operation command from the controller after the electromagnetic brake is released.

3. SIGNALS AND WIRING

(b) Off/on of the forced stop command (from controller) or EM2 (Forced stop 2)

POINT

● In the torque control mode, the forced stop deceleration function cannot be used.

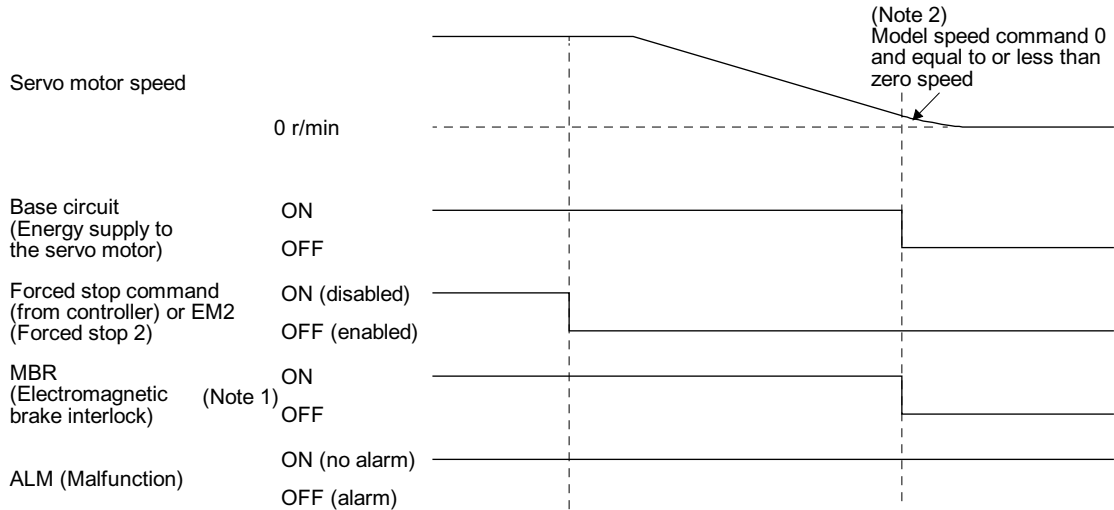

Note 1. ON: The electromagnetic brake is not activated.

OFF: The electromagnetic brake is activated.

2. The model speed command is a speed command generated in the servo amplifier for forced stop deceleration of the servo motor.

(c) Alarm occurrence

The operation status during an alarm is the same as section 3.7.

(d) Power off

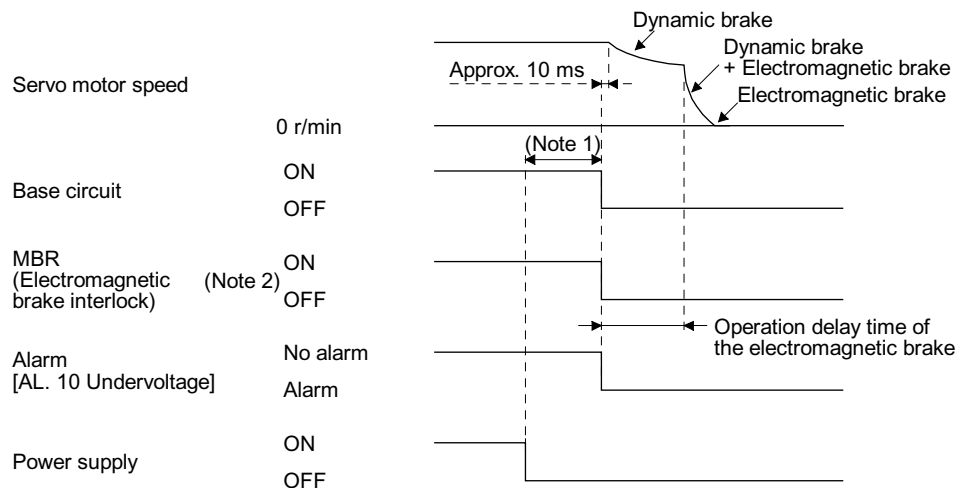

Note 1. Variable according to the operation status.

2. ON: The electromagnetic brake is not activated.

OFF: The electromagnetic brake is activated.

3. SIGNALS AND WIRING

(e) Ready-off command from controller

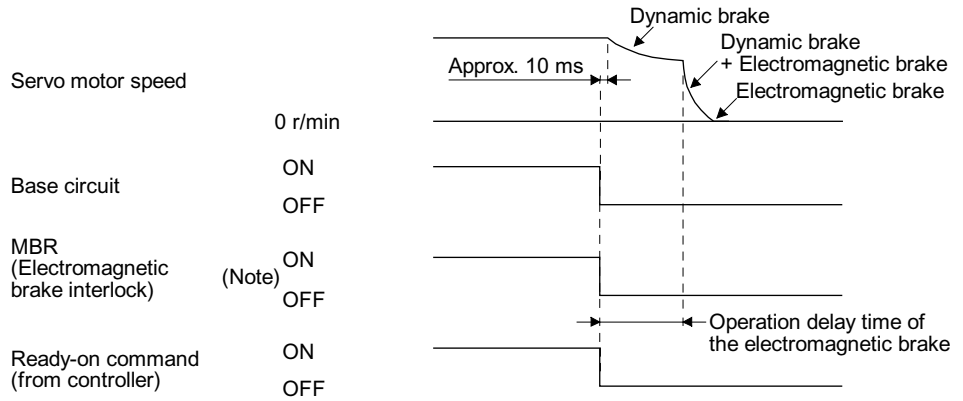

Note. ON: The electromagnetic brake is not activated.
OFF: The electromagnetic brake is activated.

(2) When you do not use the forced stop deceleration function

POINT
● To disable the function, set "0 _ _ _" in [Pr. PA04].

(a) Servo-on command (from controller) on/off
It is the same as (1) (a) in this section.

(b) Off/on of the forced stop command (from controller) or EM1 (Forced stop 1)

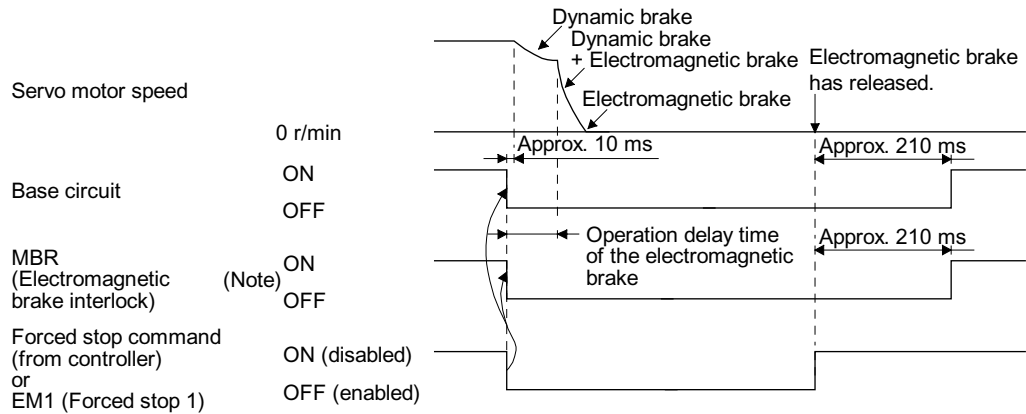

Note. ON: The electromagnetic brake is not activated.
OFF: The electromagnetic brake is activated.

(c) Alarm occurrence

The operation status during an alarm is the same as section 3.7.

(d) Power off

It is the same as (1) (d) in this section.

(e) Ready-off command from controller

It is the same as (1) (e) in this section.

3. SIGNALS AND WIRING

3.11 Grounding

WARNING ● Ground the servo amplifier and servo motor securely.
● To prevent an electric shock, always connect the protective earth (PE) terminal (marked with ⊕) of the servo amplifier to the protective earth (PE) of the cabinet.

The servo amplifier switches the power transistor on-off to supply power to the servo motor. Depending on the wiring and ground cable routing, the servo amplifier may be affected by the switching noise (due to di/dt and dv/dt) of the transistor. To prevent such a fault, refer to the following diagram and always ground. To conform to the EMC Directive, refer to "EMC Installation Guidelines".

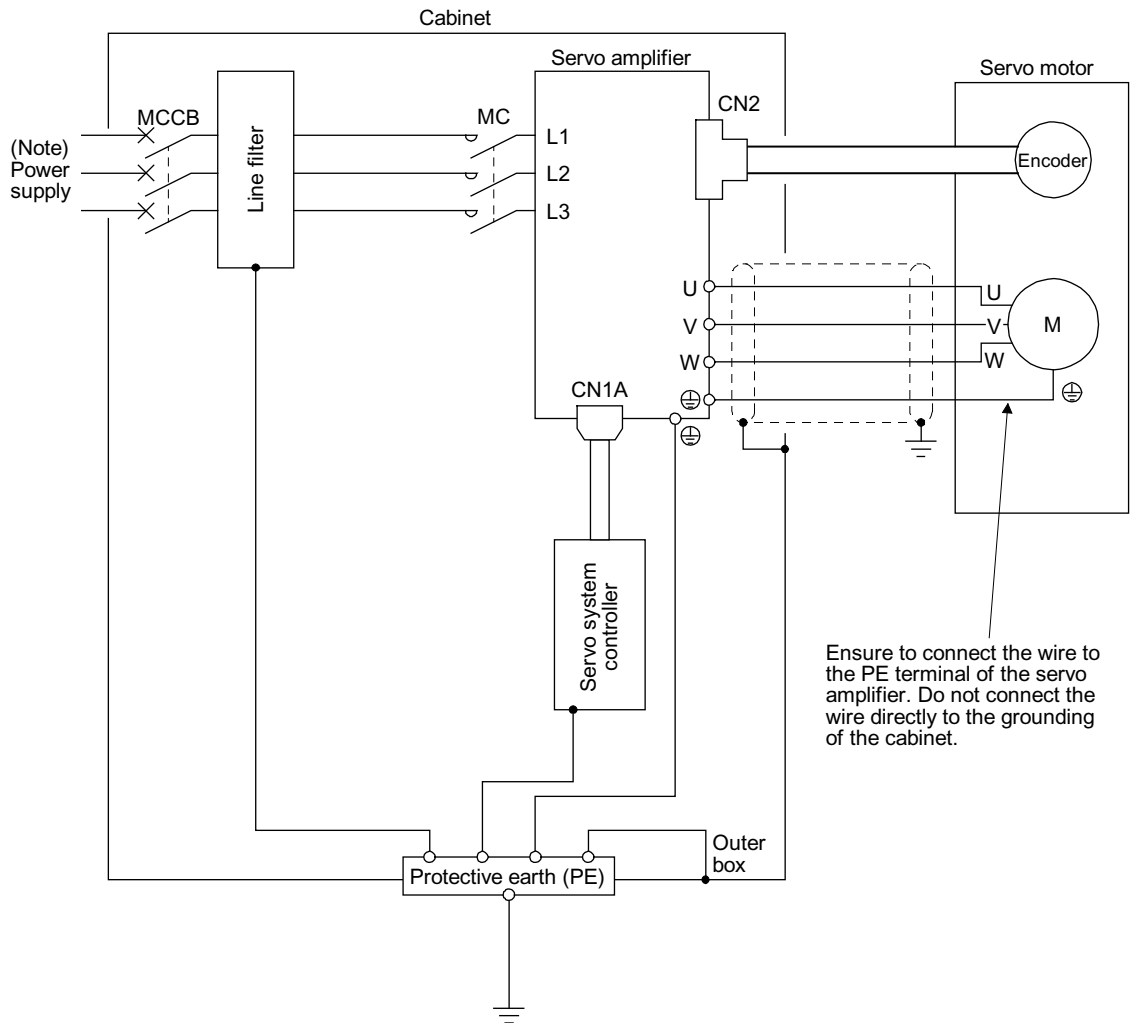

Note. For the power supply specifications, refer to section 1.3.

4. STARTUP

4. STARTUP

WARNING

- When executing a test run, follow the notice and procedures in this instruction manual. Otherwise, it may cause a malfunction, damage to the machine, or injury.
- Do not operate the switches with wet hands. Otherwise, it may cause an electric shock.

CAUTION

- Before starting operation, check the parameters. Improper settings may cause some machines to operate unexpectedly.
- The servo amplifier heat sink, regenerative resistor, servo motor, etc., may be hot while the power is on and for some time after power-off. Take safety measures such as providing covers to avoid accidentally touching them by hands and parts such as cables.
- During operation, never touch the rotor of the servo motor. Otherwise, it may cause injury.
- Before wiring, switch operation, etc., eliminate static electricity. Otherwise, it may cause a malfunction.

4. STARTUP

4.1 Switching power on for the first time

When switching power on for the first time, follow this section to make a startup.

4.1.1 Startup procedure

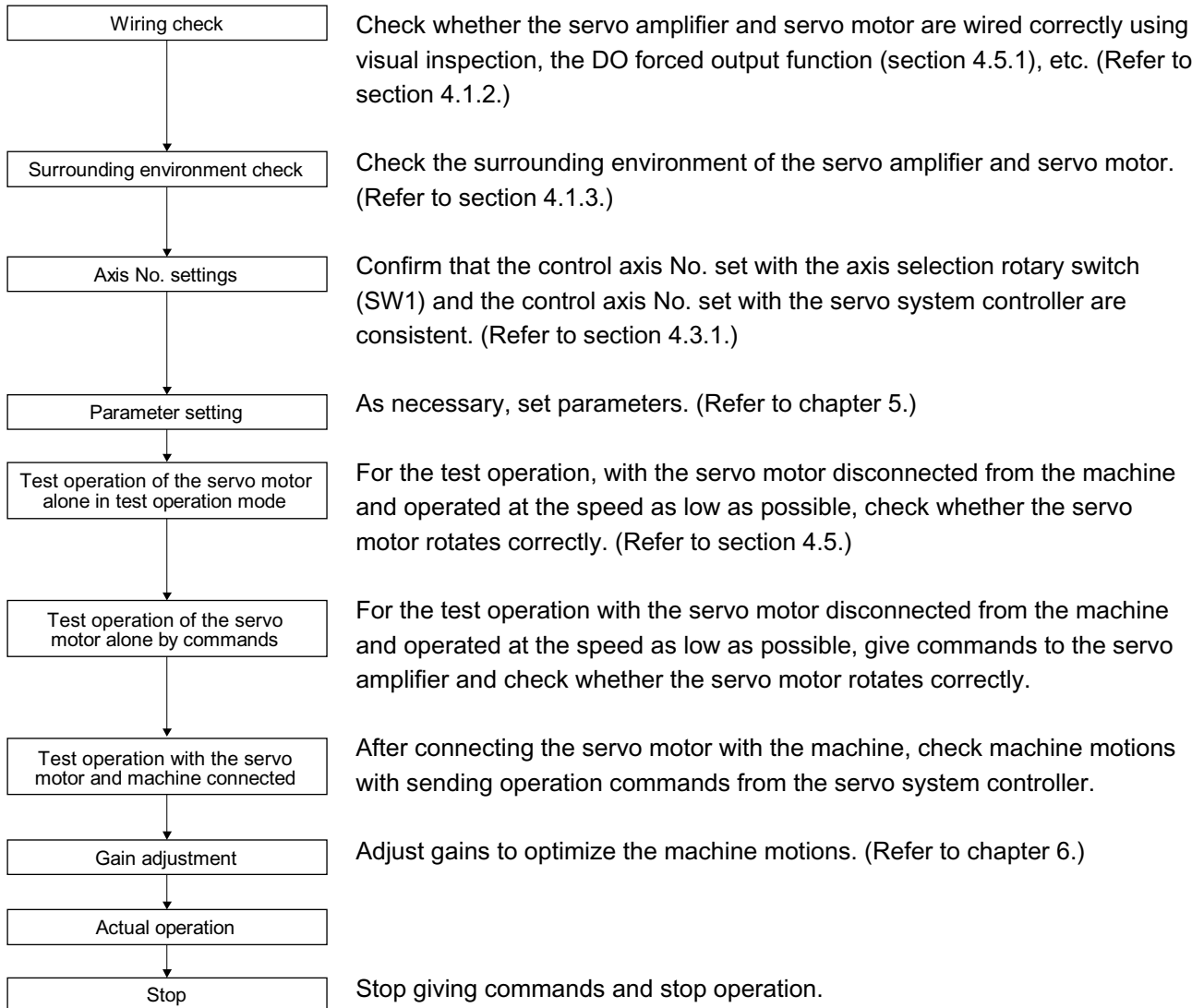

4. STARTUP

4.1.2 Wiring check

(1) Power supply system wiring

Before switching on the power supply, check the following items.

(a) Power supply system wiring

The power supplied to the power input terminals (L1/L2/L3) of the servo amplifier should satisfy the defined specifications. (Refer to section 1.3.)

(b) Connection of the servo amplifier and servo motor

- 1) The servo amplifier power output (U/V/W) should match in phase with the servo motor power input terminals (U/V/W).

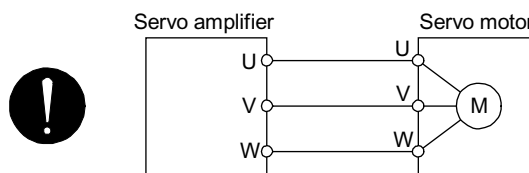

- 2) The power supplied to the servo amplifier should not be connected to the power output (U/V/W). Otherwise, the servo amplifier and servo motor will fail.

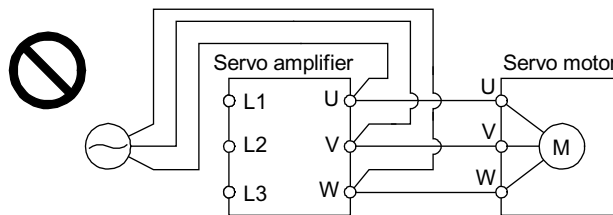

- 3) The grounding terminal of the servo motor is connected to the PE terminal of the servo amplifier.

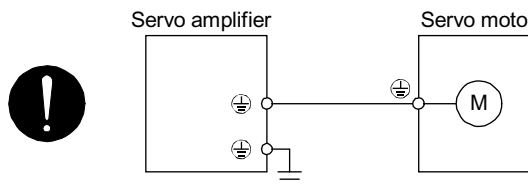

- 4) The CN2 connector of the servo amplifier should be connected to the encoder of the servo motor securely using the encoder cable.

(c) When you use an option and peripheral equipment

1) When you use a regenerative option for 1 kW or less servo amplifiers

- The built-in regenerative resistor and wirings should be removed from the servo amplifier.
- The lead wire of the built-in regenerative resistor connected to the P+ terminal and C terminal should not be connected.
- The regenerative option should be connected to the P+ terminal and C terminal.
- Twisted wires should be used. (Refer to section 11.2.4.)

2) When you use a regenerative option for 2 kW or more servo amplifiers

- The lead wire between the P+ terminal and D terminal should not be connected.
- The regenerative option should be connected to the P+ terminal and C terminal.
- Twisted wires should be used. (Refer to section 11.2.4.)

4. STARTUP

(2) I/O signal wiring

(a) The I/O signals should be connected correctly.

Use the DO forced output to forcibly turn on or off the pins of the CN3 connector. You can use the function to check the wiring. At this time, check the wiring in the servo-off status.

Refer to section 3.2 for details of I/O signal connection.

(b) A voltage exceeding 24 V DC is not applied to the pins of the CN3 connector.

(c) The wire between the plate and DOCOM of the CN3 connector should not be shorted.

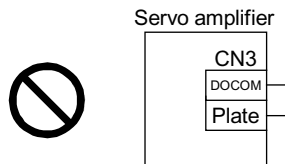

4.1.3 Surrounding environment

(1) Cable routing

(a) The wiring cables should not be stressed.

(b) The encoder cable should not be used in excess of its bending life. (Refer to section 10.4.)

(c) The connector of the servo motor should not be stressed.

(2) Environment

Signal cables and power cables are not shorted by wire offcuts, metallic dust, or the like.

4. STARTUP

4.2 Startup

Connect the servo motor with a machine after confirming that the servo motor operates properly alone.

(1) Power on

When the power supply is turned on, "b01" (for the first axis) appears on the servo amplifier display.

When you use the absolute position detection system, first power-on results in [AL. 25 Absolute position erased] and the servo system cannot be switched on. The alarm can be deactivated by switching power off once and on again.

Also, if power is switched on at the servo motor speed of 3000 r/min or faster, a position mismatch may occur due to external force or the like. Power must therefore be switched on when the servo motor is at a stop.

(2) Parameter setting

POINT
● The following encoder cables are of four-wire type. When using any of these encoder cables, set [Pr. PC04] to "1 _ _ _" to select the four-wire type. An incorrect setting will result in [AL. 16 Encoder initial communication error 1]. MR-EKCBL30M-L MR-EKCBL30M-H MR-EKCBL40M-H MR-EKCBL50M-H

Set the parameters according to the structure and specifications of the machine. Refer to chapter 5 for details.

After setting the above parameters, turn off the power as necessary. Then switch power on again to enable the parameter values.

(3) Servo-on

Enable the servo-on with the following procedure.

(a) Switch on the power.

(b) Transmit the servo-on command with the servo system controller.

When the servo-on status is enabled, the servo amplifier is ready to operate and the servo motor is locked.

(4) Home position return

Always perform home position return before starting positioning operation.

4. STARTUP

(5) Stop

Turn off the servo-on command after the servo motor has stopped, and then switch the power off.

If any of the following situations occurs, the servo amplifier suspends the running of the servo motor and brings it to a stop.

Refer to section 3.10 for the servo motor with an electromagnetic brake.

	Operation and command	Stopping condition
Servo system controller	Servo-off command	The base circuit is shut off and the servo motor coasts.
	Ready-off command	The base circuit is shut off and the dynamic brake operates to bring the servo motor to a stop.
	Forced stop command	The servo motor decelerates to a stop with the command. [AL. E7 Controller forced stop warning] occurs.
Servo amplifier	Alarm occurrence	The servo motor decelerates to a stop with the command. With some alarms, however, the dynamic brake operates to bring the servo motor to a stop. (Refer to chapter 8. (Note))
	EM2 (Forced stop 2) off	The servo motor decelerates to a stop with the command. [AL. E6 Servo forced stop warning] occurs. EM2 has the same function as that of EM1 in the torque control mode.

Note. Only a list of alarms and warnings is listed in chapter 8. Refer to "MELSERVO-JE Servo Amplifier Instruction Manual (Troubleshooting)" for details of alarms and warnings.

4.3 Switch setting and display of the servo amplifier

The control axis No. can be set with switches on the servo amplifier.

On the servo amplifier display (three-digit, seven-segment LED), check the status of communication with the servo system controller at power-on and the axis number, and diagnose a malfunction at occurrence of an alarm.

4.3.1 Axis selection rotary switch (SW1)



WARNING

●When switching the axis selection rotary switch (SW1), use an insulated screw driver. Do not use a metal screw driver. Touching patterns on electronic boards, lead of electronic parts, etc. may cause an electric shock.

POINT

- The control axis No. set to the axis selection rotary switch (SW1) should be the same as the one set to the servo system controller. The number of the axes you can set depends on the servo system controller.
- For setting the axis selection rotary switch, use a flat head screwdriver with the blade edge width of 2.1 mm to 2.3 mm and the blade edge thickness of 0.6 mm to 0.7 mm.
- Cycling the power supply enables the setting of the switch.

4. STARTUP

The control axis No. can be set in the range of 1 to 16 with the axis selection rotary switch. If the same numbers are set to different control axes in a single communication system, the system will not operate properly. The control axes may be set independently of the SSCNET III cable connection sequence. Table 4.1 shows control axis numbers corresponding to the axis selection rotary switch to set the control axis number.

Axis selection rotary switch (SW1)

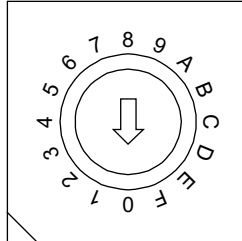

Table 4.1 Switch combination list for the control axis No. setting

Axis selection rotary switch (SW1)	Control axis No.
0	1
1	2
2	3
3	4
4	5
5	6
6	7
7	8
8	9
9	10
A	11
B	12
C	13
D	14
E	15
F	16

4. STARTUP

4.3.2 Scrolling display

(1) Normal display

When there is no alarm, the axis No. and blank are displayed in rotation.

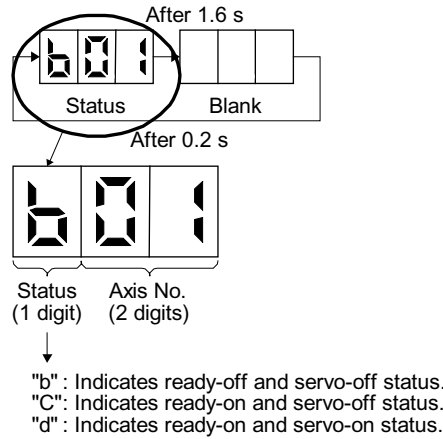

(2) Alarm display

When an alarm occurs, the alarm number (two digits) and the alarm detail (one digit) are displayed following the status display. For example, the following shows when [AL. 32 Overcurrent] is occurring.

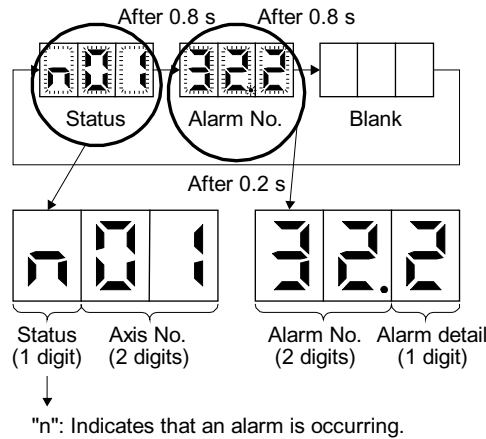

If an alarm occurs during the network initial communication, the alarm No. (2 digits), alarm detail (1 digit), and network initial communication status are displayed following the status display. This is an example of the alarm display for when [AL. 16.1 Encoder initial communication - Receive data error 1] is occurring.

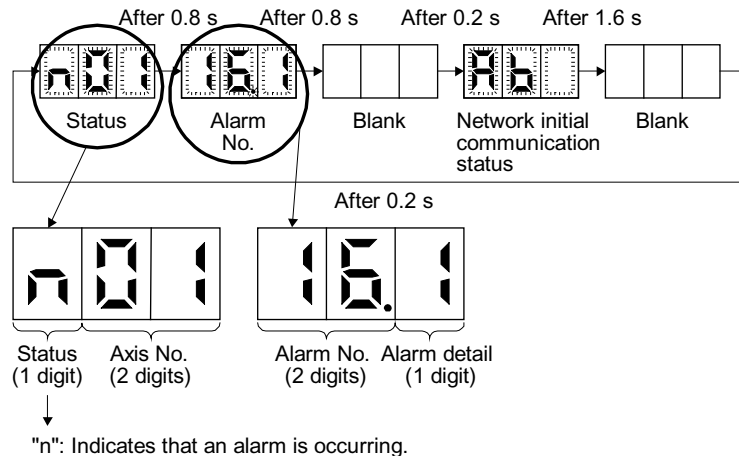

4. STARTUP

4.3.3 Status display of an axis

(1) Display sequence

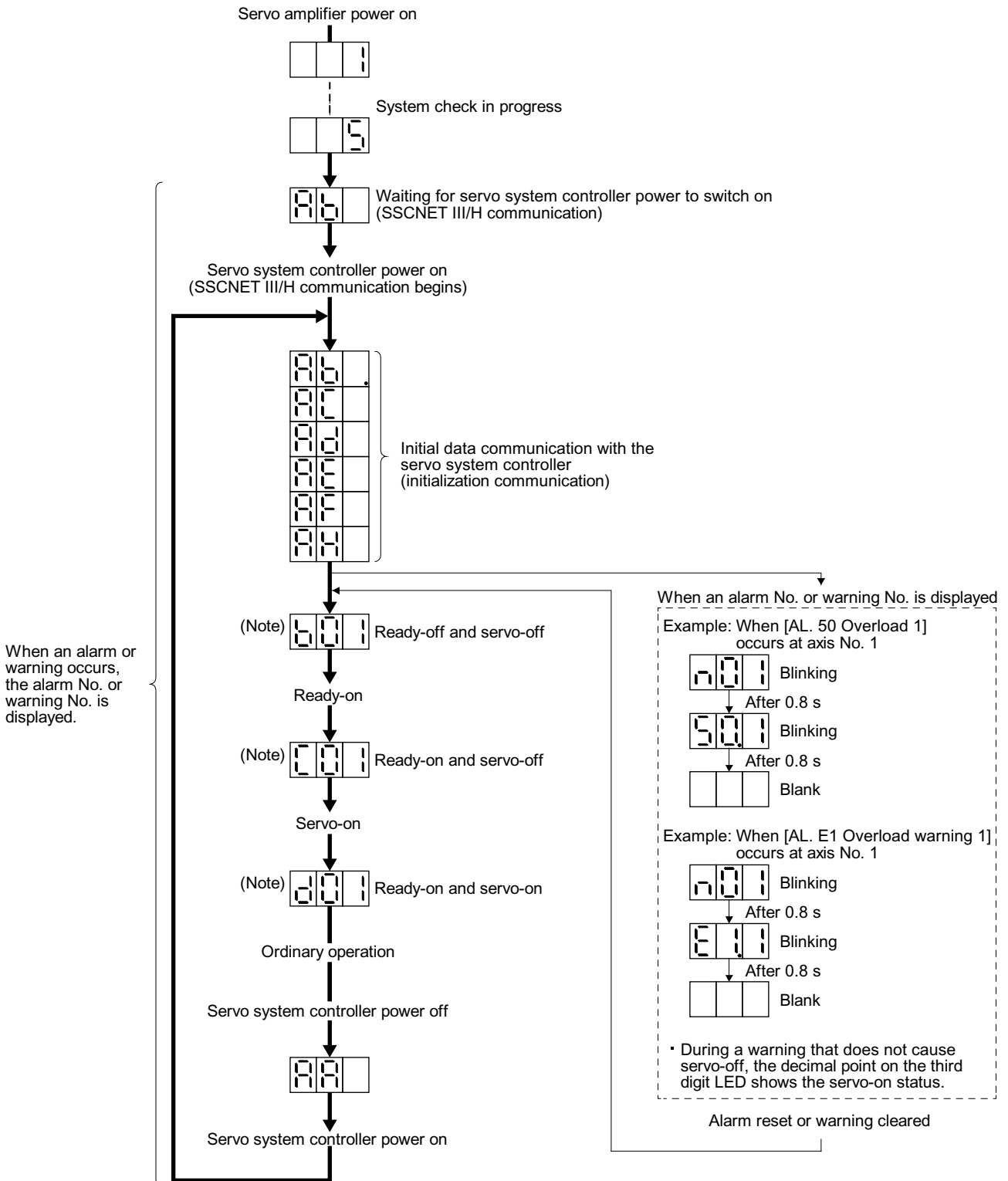

Note.

01	02	...	16
Axis No. 1	Axis No. 2		Axis No. 16

 The segment of the last 2 digits shows the axis number.

4. STARTUP

(2) Indication list

POINT
<p>● Refer to section 1.6 of "MELSERVO-JE Servo Amplifier Instruction Manual (Troubleshooting)" for troubleshooting at startup.</p>

Indication	Status	Description
	Initializing	System check in progress
	Initializing	<ul style="list-style-type: none"> The servo amplifier power was switched on when the servo system controller power was off. The control axis No. set to the axis selection rotary switch (SW1) does not match the one set to the servo system controller. A servo amplifier malfunctioned, or communication error occurred with the servo system controller or the previous axis servo amplifier. In this case, the indication changes as follows: "Ab", "AC", "Ad", and "Ab" The servo system controller is malfunctioning.
	Initializing	During an initial setting for communication specifications
	Initializing	An initial setting for communication specifications is completed, and then it synchronized with the servo system controller.
	Initializing	During initial parameter setting communication with the servo system controller
	Initializing	During the servo motor and encoder information and telecommunication with the servo system controller
	Initializing	During initial signal data communication with the servo system controller
	Initializing completion	The process for initial data communication with the servo system controller is completed.
	Initializing standby	The power supply of the servo system controller or previous axis servo amplifier was turned off while the power supply of the servo amplifier is on.
(Note 1)	Ready-off	The ready-off command from the servo system controller was received.
(Note 1)	Servo-on	The servo-on command from the servo system controller was received.
(Note 1)	Servo-off	The servo-off command from the servo system controller was received.
(Note 2)	Alarm and warning	The alarm No. and the warning No. that occurred are displayed. (Refer to chapter 8. (Note 4))
	CPU error	A CPU watchdog error has occurred.
(Note 1)	(Note 3) Test operation mode	JOG operation, positioning operation, program operation, output signal (DO) forced output, or motor-less operation was set.

Note 1. The meanings of ## are listed below.

##	Description
01	First axis
}	}
16	Sixteenth axis

2. "****" indicates the alarm No. and the warning No.

3. Requires the MR Configurator2.

4. Only a list of alarms and warnings is listed in chapter 8. Refer to "MELSERVO-JE Servo Amplifier Instruction Manual (Troubleshooting)" for details of alarms and warnings.

4. STARTUP

4.4 Test operation

Before starting actual operation, perform test operation to make sure that the machine operates normally. Refer to section 4.2 for how to power on and off the servo amplifier.

POINT

- If necessary, verify controller programs by using motor-less operation. Refer to section 4.5.2 for the motor-less operation.

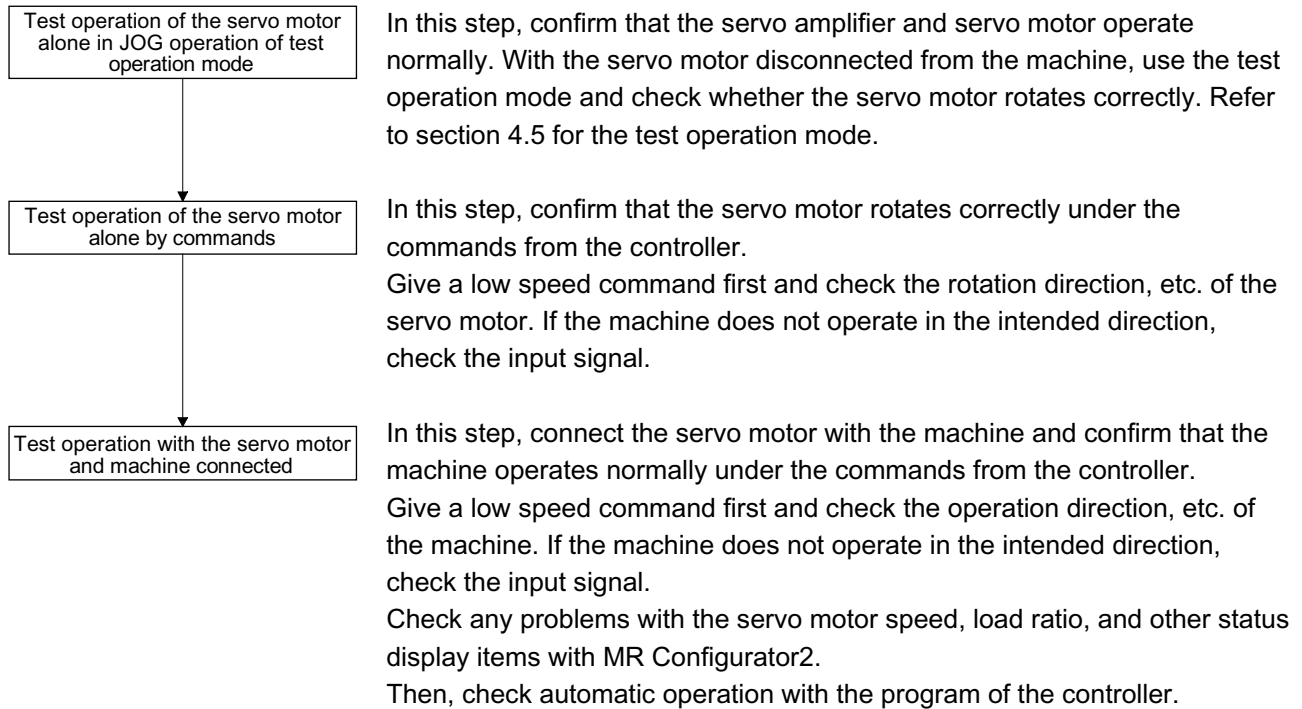

4.5 Test operation mode



CAUTION

- The test operation mode is designed for checking servo operation. It is not for checking machine operation. Do not use this mode with the machine. Always use the servo motor alone.
- If the servo motor operates abnormally, use EM2 (Forced stop 2) to stop it.

POINT

- The content described in this section indicates that the servo amplifier and a personal computer are directly connected.

By using a personal computer and MR Configurator2, you can execute JOG operation, positioning operation, output signal forced output, and program operation without connecting the servo system controller.

4. STARTUP

4.5.1 Test operation mode in MR Configurator2

POINT
<ul style="list-style-type: none"> ● When "_ _ 1 _" is set in [Pr. PC05] to enable the test operation mode, the SSCNET III/H communication for the servo amplifier in the test operation mode and the following servo amplifiers is blocked. ● When setting [Pr. PC05] to "_ _ 1 _", set it via CN5 (USB connector). When setting it, disconnect the SSCNET III cable or turn off the power supply of the controller.

(1) Test operation mode

(a) JOG operation

JOG operation can be performed without using the servo system controller. Use this operation with the forced stop reset. This operation may be used independently of whether the servo is on or off and whether the servo system controller is connected or not.

Exercise control on the JOG operation screen of MR Configurator2.

1) Operation pattern

Item	Initial value	Setting range
Speed [r/min]	200	0 to maximum speed
Acceleration/deceleration time constant [ms]	1000	0 to 50000

2) Operation method

- The check box "Rotation only while the CCW or CW button is being pushed" is checked.

Operation	Screen control
Forward rotation start	Keep pressing "Forward CCW".
Reverse rotation start	Keep pressing "Reverse CW".
Stop	Release "Forward CCW" or "Reverse CW".
Forced stop	Click "Forced Stop".

- The check box "Rotation only while the CCW or CW button is being pushed" is unchecked.

Operation	Screen control
Forward rotation start	Click "Forward CCW".
Reverse rotation start	Click "Reverse CW".
Stop	Click "Stop".
Forced stop	Click "Forced Stop".

4. STARTUP

(b) Positioning operation

Positioning operation can be performed without using the servo system controller. Use this operation with the forced stop reset. This operation may be used independently of whether the servo is on or off and whether the servo system controller is connected or not.

Exercise control on the positioning operation screen of MR Configurator2.

1) Operation pattern

Item	Initial value	Setting range
Travel distance [pulse]	4000	0 to 99999999
Speed [r/min]	200	0 to maximum speed
Acceleration/deceleration time constant [ms]	1000	0 to 50000
Repeat pattern	Fwd. rot. (CCW) to rev. rot. (CW)	Fwd. rot. (CCW) to rev. rot. (CW) Fwd. rot. (CCW) to fwd. rot. (CCW) Rev. rot. (CW) to fwd. rot. (CCW) Rev. rot. (CW) to rev. rot. (CW)
Dwell time [s]	2.0	0.1 to 50.0
Number of repeats [time]	1	1 to 9999

2) Operation method

Operation	Screen control
Forward rotation start	Click "Forward CCW".
Reverse rotation start	Click "Reverse CW".
Pause	Click "Pause".
Stop	Click "Stop".
Forced stop	Click "Forced Stop".

(c) Program operation

Positioning operation can be performed in two or more operation patterns combined, without using the servo system controller. Use this operation with the forced stop reset. This operation may be used independently of whether the servo is on or off and whether the servo system controller is connected or not.

Exercise control on the program operation screen of MR Configurator2. For details, refer to Help of MR Configurator2.

Operation	Screen control
Start	Click "Operation Start".
Pause	Click "Pause".
Stop	Click "Stop".
Forced stop	Click "Forced Stop".

(d) Output signal (DO) forced output

Output signals can be switched on or off forcibly independently of the servo status. This function is used for output signal wiring check, etc. Exercise control on the DO forced output screen of MR Configurator2.

4. STARTUP

(2) Operation procedure

- 1) Set "_ _ 1 _" in [Pr. PC05] and cycle the power.

When initialization is completed, the decimal point on the first digit will flicker.

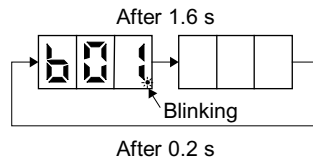

When an alarm or warning also occurs during the test operation, the decimal point on the first digit will flicker as follows.

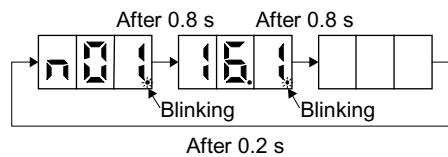

- 2) Start operation with the personal computer.

4.5.2 Motor-less operation in the controller

POINT	
	<ul style="list-style-type: none"> ● Use motor-less operation which is available by making the servo system controller parameter setting. ● Connect the servo amplifier with the servo system controller before the motor-less operation.

(1) Motor-less operation

Without connecting a servo motor to the servo amplifier, output signals or status displays can be provided in response to the servo system controller commands as if the servo motor is actually running. This operation may be used to check the servo system controller sequence. Use this operation with the forced stop reset. Use this operation with the servo amplifier connected to the servo system controller. To stop the motor-less operation, set the motor-less operation selection to "Disable" in the servo parameter setting of the servo system controller. When the power supply is turned on next time, motor-less operation will be disabled.

(a) Load conditions

Load item	Condition
Load torque	0
Load to motor inertia ratio	[Pr. PB06 Load to motor inertia ratio]

4. STARTUP

(b) Alarms

The following alarms and warnings do not occur. However, the other alarms and warnings occur as when the servo motor is connected.

- [AL. 16 Encoder initial communication error 1]
- [AL. 1E Encoder initial communication error 2]
- [AL. 1F Encoder initial communication error 3]
- [AL. 20 Encoder normal communication error 1]
- [AL. 21 Encoder normal communication error 2]
- [AL. 25 Absolute position erased]
- [AL. 92 Battery cable disconnection warning]
- [AL. 9F Battery warning]

(2) Operation procedure

- 1) Set the servo amplifier to the servo-off status.
- 2) Set "_ _ 0 1" in [Pr. PC05] and cycle the power.
- 3) Start the motor-less operation with the servo system controller.
The display shows the following screen.

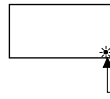

└ The decimal point blinks.

5. PARAMETERS

5. PARAMETERS

CAUTION

- Never make a drastic adjustment or change to the parameter values as doing so will make the operation unstable.
- Do not change the parameter settings as described below. Doing so may cause an unexpected condition, such as failing to start up the servo amplifier.
 - Changing the values of the parameters for manufacturer setting
 - Setting a value out of the range
 - Changing the fixed values in the digits of a parameter
- When you write parameters with the controller, make sure that the control axis No. of the servo amplifier is set correctly. Otherwise, the parameter settings of another axis may be written, possibly causing the servo amplifier to be an unexpected condition.

POINT

- When you connect the amplifier to a servo system controller, servo parameter values of the servo system controller will be written to each parameter.
- Some parameters and their ranges may not be configured depending on the servo system controller model, servo amplifier software version, and MR Configurator2 software version. For details, refer to the servo system controller user's manual. Check the software version of the servo amplifier with MR Configurator2.

5.1 Parameter list

POINT

- The parameter whose symbol is preceded by * is enabled with the following conditions:
 - *: To enable the parameter value, power off the servo amplifier for 1 s or longer and power on the amplifier or reset the controller after setting the parameter. However, the time will be longer depending on a setting value of [Pr. PF25 Instantaneous power failure tough drive - Detection time] when "instantaneous power failure tough drive selection" is enabled in [Pr. PA20].
 - ** : To enable the parameter value, power off the servo amplifier for 1 s or longer and power on the amplifier. However, the time will be longer depending on a setting value of [Pr. PF25 Instantaneous power failure tough drive - Detection time] when "instantaneous power failure tough drive selection" is enabled in [Pr. PA20].

5. PARAMETERS

5.1.1 Basic setting parameters ([Pr. PA_ _])

No.	Symbol	Name	Initial value	Unit
PA01		For manufacturer setting	1000h	
PA02	**REG	Regenerative option	0000h	
PA03	*ABS	Absolute position detection system	0000h	
PA04	*AOP1	Function selection A-1	2000h	
PA05		For manufacturer setting	10000	
PA06			1	
PA07			1	
PA08	ATU	Auto tuning mode	0001h	
PA09	RSP	Auto tuning response	16	
PA10	INP	In-position range	100	[pulse]
PA11		For manufacturer setting	1000.0	
PA12			1000.0	
PA13			0000h	
PA14	*POL	Rotation direction selection	0	
PA15		For manufacturer setting	0	
PA16			0	
PA17			0000h	
PA18			0000h	
PA19	*BLK	Parameter writing inhibit	00AAh	
PA20	*TDS	Tough drive setting	0000h	
PA21	*AOP3	Function selection A-3	0001h	
PA22		For manufacturer setting	0000h	
PA23	DRAT	Drive recorder arbitrary alarm trigger setting	0000h	
PA24	AOP4	Function selection A-4	0000h	
PA25	OTHOV	One-touch tuning - Overshoot permissible level	0	[%]
PA26	*AOP5	Function selection A-5	0000h	
PA27	*HTL	Hot line forced stop function	0000h	
PA28	**AOP6	Function selection A-6	0000h	
PA29		For manufacturer setting	0000h	
PA30			0000h	
PA31			0000h	
PA32			0000h	

5. PARAMETERS

5.1.2 Gain/filter setting parameters ([Pr. PB_ _])

No.	Symbol	Name	Initial value	Unit
PB01	FILT	Adaptive tuning mode (adaptive filter II)	0000h	
PB02	VRFT	Vibration suppression control tuning mode (advanced vibration suppression control II)	0000h	
PB03	TFBGN	Torque feedback loop gain	18000	[rad/s]
PB04	FFC	Feed forward gain	0	[%]
PB05		For manufacturer setting	500	
PB06	GD2	Load to motor inertia ratio	7.00	[Multiplier]
PB07	PG1	Model loop gain	15.0	[rad/s]
PB08	PG2	Position loop gain	37.0	[rad/s]
PB09	VG2	Speed loop gain	823	[rad/s]
PB10	VIC	Speed integral compensation	33.7	[ms]
PB11	VDC	Speed differential compensation	980	
PB12	OVA	Overshoot amount compensation	0	[%]
PB13	NH1	Machine resonance suppression filter 1	4500	[Hz]
PB14	NHQ1	Notch shape selection 1	0000h	
PB15	NH2	Machine resonance suppression filter 2	4500	[Hz]
PB16	NHQ2	Notch shape selection 2	0000h	
PB17	NHF	Shaft resonance suppression filter	0000h	
PB18	LPF	Low-pass filter setting	3141	[rad/s]
PB19	VRF11	Vibration suppression control 1 - Vibration frequency	100.0	[Hz]
PB20	VRF12	Vibration suppression control 1 - Resonance frequency	100.0	[Hz]
PB21	VRF13	Vibration suppression control 1 - Vibration frequency damping	0.00	
PB22	VRF14	Vibration suppression control 1 - Resonance frequency damping	0.00	
PB23	VFBF	Low-pass filter selection	0000h	
PB24	*MVS	Slight vibration suppression control	0000h	
PB25	*BOP1	Function selection B-1	0000h	
PB26	*CDP	Gain switching function	0000h	
PB27	CDL	Gain switching condition	10	[kpulse/s]/ [pulse]/ [r/min]
PB28	CDT	Gain switching time constant	1	[ms]
PB29	GD2B	Load to motor inertia ratio after gain switching	7.00	[Multiplier]
PB30	PG2B	Position loop gain after gain switching	0.0	[rad/s]
PB31	VG2B	Speed loop gain after gain switching	0	[rad/s]
PB32	VICB	Speed integral compensation after gain switching	0.0	[ms]
PB33	VRF11B	Vibration suppression control 1 - Vibration frequency after gain switching	0.0	[Hz]
PB34	VRF12B	Vibration suppression control 1 - Resonance frequency after gain switching	0.0	[Hz]
PB35	VRF13B	Vibration suppression control 1 - Vibration frequency damping after gain switching	0.00	
PB36	VRF14B	Vibration suppression control 1 - Resonance frequency damping after gain switching	0.00	
PB37		For manufacturer setting	1600	
PB38			0.00	
PB39			0.00	
PB40			0.00	
PB41			0	
PB42			0	
PB43			0000h	
PB44			0.00	
PB45	CNHF	Command notch filter	0000h	

5. PARAMETERS

No.	Symbol	Name	Initial value	Unit
PB46	NH3	Machine resonance suppression filter 3	4500	[Hz]
PB47	NHQ3	Notch shape selection 3	0000h	
PB48	NH4	Machine resonance suppression filter 4	4500	[Hz]
PB49	NHQ4	Notch shape selection 4	0000h	
PB50	NH5	Machine resonance suppression filter 5	4500	[Hz]
PB51	NHQ5	Notch shape selection 5	0000h	
PB52	VRF21	Vibration suppression control 2 - Vibration frequency	100.0	[Hz]
PB53	VRF22	Vibration suppression control 2 - Resonance frequency	100.0	[Hz]
PB54	VRF23	Vibration suppression control 2 - Vibration frequency damping	0.00	
PB55	VRF24	Vibration suppression control 2 - Resonance frequency damping	0.00	
PB56	VRF21B	Vibration suppression control 2 - Vibration frequency after gain switching	0.0	[Hz]
PB57	VRF22B	Vibration suppression control 2 - Resonance frequency after gain switching	0.0	[Hz]
PB58	VRF23B	Vibration suppression control 2 - Vibration frequency damping after gain switching	0.00	
PB59	VRF24B	Vibration suppression control 2 - Resonance frequency damping after gain switching	0.00	
PB60	PG1B	Model loop gain after gain switching	0.0	[rad/s]
PB61		For manufacturer setting	0.0	
PB62			0000h	
PB63			0000h	
PB64			0000h	

5.1.3 Extension setting parameters ([Pr. PC_ _])

No.	Symbol	Name	Initial value	Unit
PC01	ERZ	Error excessive alarm level	0	[rev]
PC02	MBR	Electromagnetic brake sequence output	0	[ms]
PC03		For manufacturer setting	0000h	
PC04	**COP1	Function selection C-1	0020h	
PC05	**COP2	Function selection C-2	0000h	
PC06	*COP3	Function selection C-3	0000h	
PC07	ZSP	Zero speed	50	[r/min]
PC08	OSL	Overspeed alarm detection level	0	[r/min]
PC09		For manufacturer setting	0000h	
PC10			0000h	
PC11			0	
PC12			0	
PC13			0	
PC14			0	
PC15			0	
PC16			0000h	
PC17	**COP4	Function selection C-4	0000h	
PC18	*COP5	Function selection C-5	0000h	
PC19		For manufacturer setting	0000h	
PC20	*COP7	Function selection C-7	0000h	

5. PARAMETERS

No.	Symbol	Name	Initial value	Unit
PC21	*BPS	Alarm history clear	0000h	
PC22		For manufacturer setting	0	
PC23			0000h	
PC24	RSBR	Forced stop deceleration time constant	100	[ms]
PC25		For manufacturer setting	0	
PC26			0000h	
PC27			0000h	
PC28			0000h	
PC29	*COPB	Function selection C-B	0000h	
PC30		For manufacturer setting	0	
PC31	RSUP1	Vertical axis freefall prevention compensation amount	0	[0.0001 rev]
PC32		For manufacturer setting	0000h	
PC33			0	
PC34			100	
PC35			0000h	
PC36			0000h	
PC37			0000h	
PC38	ERW	Error excessive warning level	0	[rev]
PC39		For manufacturer setting	0000h	
PC40			0000h	
PC41			0000h	
PC42			0000h	
PC43			0000h	
PC44			0000h	
PC45			0000h	
PC46			0000h	
PC47			0000h	
PC48			0000h	
PC49			0000h	
PC50			0000h	
PC51			0000h	
PC52			0000h	
PC53			0000h	
PC54			0000h	
PC55			0000h	
PC56			0000h	
PC57			0000h	
PC58			0000h	
PC59			0000h	
PC60			0000h	
PC61			0000h	
PC62			0000h	
PC63			0000h	
PC64			0000h	

5. PARAMETERS

5.1.4 I/O setting parameters ([Pr. PD_ _])

No.	Symbol	Name	Initial value	Unit
PD01		For manufacturer setting	0000h	
PD02	*DIA2	Input signal automatic on selection 2	0000h	
PD03	*DI1	Input device selection 1	0000h	
PD04	*DI2	Input device selection 2	0000h	
PD05	*DI3	Input device selection 3	0000h	
PD06		For manufacturer setting	0000h	
PD07	*DO1	Output device selection 1	0005h	
PD08	*DO2	Output device selection 2	0000h	
PD09	*DO3	Output device selection 3	0000h	
PD10		For manufacturer setting	0000h	
PD11	*DIF	Input filter setting (Note)	0004h	
PD12		For manufacturer setting	0000h	
PD13	*DOP2	Function selection D-2	0000h	
PD14	*DOP3	Function selection D-3	0000h	
PD15		For manufacturer setting	0000h	
PD16			0000h	
PD17			0000h	
PD18			0000h	
PD19			0000h	
PD20			0	
PD21			0	
PD22			0	
PD23			0	
PD24			0000h	
PD25			0000h	
PD26			0000h	
PD27			0000h	
PD28			0000h	
PD29			0000h	
PD30			0	
PD31			0	
PD32			0	
PD33			0000h	
PD34			0000h	
PD35			0000h	
PD36			0000h	
PD37			0000h	
PD38			0000h	
PD39			0000h	
PD40			0000h	
PD41			0000h	
PD42			0000h	
PD43			0000h	
PD44			0000h	
PD45			0000h	
PD46			0000h	
PD47			0000h	
PD48			0000h	

Note. Refer to the servo system controller instruction manual for the setting.

5. PARAMETERS

5.1.5 Extension setting 2 parameters ([Pr. PE_ _])

No.	Symbol	Name	Initial value	Unit
PE01		For manufacturer setting	0000h	
PE02			0000h	
PE03			0000h	
PE04			0	
PE05			0	
PE06			0	
PE07			0	
PE08			0	
PE09			0000h	
PE10			0000h	
PE11			0000h	
PE12			0000h	
PE13			0000h	
PE14			0111h	
PE15			20	
PE16			0000h	
PE17			0000h	
PE18			0000h	
PE19			0000h	
PE20			0000h	
PE21			0000h	
PE22			0000h	
PE23			0000h	
PE24			0000h	
PE25			0000h	
PE26			0000h	
PE27			0000h	
PE28			0000h	
PE29			0000h	
PE30			0000h	
PE31			0000h	
PE32			0000h	
PE33			0000h	
PE34			0	
PE35			0	
PE36			0.0	
PE37			0.00	
PE38			0.00	
PE39			0	
PE40			0000h	
PE41	EOP3	Function selection E-3	0000h	
PE42		For manufacturer setting	0	
PE43			0.0	
PE44	LMCP	Lost motion compensation positive-side compensation value selection	0	[0.01%]
PE45	LMCN	Lost motion compensation negative-side compensation value selection	0	[0.01%]
PE46	LMFLT	Lost motion filter setting	0	[0.1 ms]
PE47	TOF	Torque offset	0	[0.01%]
PE48	*LMOP	Lost motion compensation function selection	0000h	
PE49	LMCD	Lost motion compensation timing	0	[0.1 ms]
PE50	LMCT	Lost motion compensation non-sensitive band	0	[pulse]/ [kpulse]

5. PARAMETERS

No.	Symbol	Name	Initial value	Unit
PE51		For manufacturer setting	0000h	
PE52			0000h	
PE53			0000h	
PE54			0000h	
PE55			0000h	
PE56			0000h	
PE57			0000h	
PE58			0000h	
PE59			0000h	
PE60			0000h	
PE61			0.00	
PE62			0.00	
PE63			0.00	
PE64			0.00	

5.1.6 Extension setting 3 parameters ([Pr. PF_ _])

No.	Symbol	Name	Initial value	Unit
PF01		For manufacturer setting	0000h	
PF02			0000h	
PF03			0000h	
PF04			0	
PF05			0000h	
PF06	*FOP5	Function selection F-5	0003h	
PF07		For manufacturer setting	0000h	
PF08			0000h	
PF09			0	
PF10			0	
PF11			0	
PF12	DBT	Electronic dynamic brake operating time	2000	[ms]
PF13		For manufacturer setting	0000h	
PF14			10	
PF15			0000h	
PF16			0000h	
PF17			0000h	
PF18			0000h	
PF19			0000h	
PF20			0000h	
PF21	DRT	Drive recorder switching time setting	0	[s]
PF22		For manufacturer setting	200	
PF23	OSCL1	Vibration tough drive - Oscillation detection level	50	[%]
PF24	*OSCL2	Vibration tough drive function selection	0000h	
PF25	CVAT	Instantaneous power failure tough drive - Detection time	200	[ms]
PF26		For manufacturer setting	0	
PF27			0	
PF28			0	
PF29			0000h	
PF30			0	

5. PARAMETERS

No.	Symbol	Name	Initial value	Unit
PF31	FRIC	Machine diagnosis function - Friction judgment speed	0	[r/min]
PF32		For manufacturer setting	50	
PF33			0000h	
PF34			0000h	
PF35			0000h	
PF36			0000h	
PF37			0000h	
PF38			0000h	
PF39			0000h	
PF40			0000h	
PF41			0000h	
PF42			0000h	
PF43			0000h	
PF44			0	
PF45			0000h	
PF46			0000h	
PF47			0000h	
PF48			0000h	

5. PARAMETERS

5.2 Detailed list of parameters

POINT
● Set a value in each "x" in the "Setting digit" columns.

5.2.1 Basic setting parameters ([Pr. PA_ _])

No.	Symbol	Name and function	Initial value [unit]	Setting range															
PA02	**REG	<p>Regenerative option Select a regenerative option. Incorrect setting may cause the regenerative option to burn. If a selected regenerative option is not for use with the servo amplifier, [AL. 37 Parameter error] occurs.</p> <table border="1"> <thead> <tr> <th>Setting digit</th> <th>Explanation</th> <th>Initial value</th> </tr> </thead> <tbody> <tr> <td>_ _ x x</td> <td> <p>Regenerative option selection</p> <p>00: No regenerative option is used.</p> <ul style="list-style-type: none"> ▪ For a servo amplifier of 200 W or less, no regenerative resistor is used. ▪ For a servo amplifier of 0.4 kW to 3 kW, a built-in regenerative resistor is used. <p>02: MR-RB032 03: MR-RB12 04: MR-RB32 05: MR-RB30 06: MR-RB50 (A cooling fan is required.)</p> </td> <td>00h</td> </tr> <tr> <td>_ x _ _</td> <td>For manufacturer setting</td> <td>0h</td> </tr> <tr> <td>x _ _ _</td> <td></td> <td>0h</td> </tr> </tbody> </table>	Setting digit	Explanation	Initial value	_ _ x x	<p>Regenerative option selection</p> <p>00: No regenerative option is used.</p> <ul style="list-style-type: none"> ▪ For a servo amplifier of 200 W or less, no regenerative resistor is used. ▪ For a servo amplifier of 0.4 kW to 3 kW, a built-in regenerative resistor is used. <p>02: MR-RB032 03: MR-RB12 04: MR-RB32 05: MR-RB30 06: MR-RB50 (A cooling fan is required.)</p>	00h	_ x _ _	For manufacturer setting	0h	x _ _ _		0h	Refer to the "Name and function" column.				
Setting digit	Explanation	Initial value																	
_ _ x x	<p>Regenerative option selection</p> <p>00: No regenerative option is used.</p> <ul style="list-style-type: none"> ▪ For a servo amplifier of 200 W or less, no regenerative resistor is used. ▪ For a servo amplifier of 0.4 kW to 3 kW, a built-in regenerative resistor is used. <p>02: MR-RB032 03: MR-RB12 04: MR-RB32 05: MR-RB30 06: MR-RB50 (A cooling fan is required.)</p>	00h																	
_ x _ _	For manufacturer setting	0h																	
x _ _ _		0h																	
PA03	*ABS	<p>Absolute position detection system Set this parameter when using the absolute position detection system.</p> <table border="1"> <thead> <tr> <th>Setting digit</th> <th>Explanation</th> <th>Initial value</th> </tr> </thead> <tbody> <tr> <td>_ _ _ x</td> <td> <p>Absolute position detection system selection</p> <p>0: Disabled (used in the incremental system) 1: Enabled (used in the absolute position detection system)</p> </td> <td>0h</td> </tr> <tr> <td>_ _ x _</td> <td>For manufacturer setting</td> <td>0h</td> </tr> <tr> <td>_ x _ _</td> <td></td> <td>0h</td> </tr> <tr> <td>x _ _ _</td> <td></td> <td>0h</td> </tr> </tbody> </table>	Setting digit	Explanation	Initial value	_ _ _ x	<p>Absolute position detection system selection</p> <p>0: Disabled (used in the incremental system) 1: Enabled (used in the absolute position detection system)</p>	0h	_ _ x _	For manufacturer setting	0h	_ x _ _		0h	x _ _ _		0h	Refer to the "Name and function" column.	
Setting digit	Explanation	Initial value																	
_ _ _ x	<p>Absolute position detection system selection</p> <p>0: Disabled (used in the incremental system) 1: Enabled (used in the absolute position detection system)</p>	0h																	
_ _ x _	For manufacturer setting	0h																	
_ x _ _		0h																	
x _ _ _		0h																	

5. PARAMETERS

No.	Symbol	Name and function	Initial value [unit]	Setting range																						
PA04	*AOP1	Function selection A-1 Select the forced stop input and forced stop deceleration function.	Refer to the "Name and function" column.																							
<table border="1"> <thead> <tr> <th>Setting digit</th> <th>Explanation</th> <th>Initial value</th> </tr> </thead> <tbody> <tr> <td>___x</td> <td rowspan="2">For manufacturer setting</td> <td>0h</td> </tr> <tr> <td>__x_</td> <td>0h</td> </tr> <tr> <td>_x__</td> <td>Servo forced stop selection 0: Enabled (The forced stop input EM2 or EM1 is used.) 1: Disabled (The forced stop input EM2 and EM1 are not used.) Refer to table 5.1 for details.</td> <td>0h</td> </tr> <tr> <td>x___</td> <td>Forced stop deceleration function selection 0: Forced stop deceleration function disabled (EM1 is used.) 2: Forced stop deceleration function enabled (EM2 is used.) Refer to table 5.1 for details.</td> <td>2h</td> </tr> </tbody> </table>					Setting digit	Explanation	Initial value	___x	For manufacturer setting	0h	__x_	0h	_x__	Servo forced stop selection 0: Enabled (The forced stop input EM2 or EM1 is used.) 1: Disabled (The forced stop input EM2 and EM1 are not used.) Refer to table 5.1 for details.	0h	x___	Forced stop deceleration function selection 0: Forced stop deceleration function disabled (EM1 is used.) 2: Forced stop deceleration function enabled (EM2 is used.) Refer to table 5.1 for details.	2h								
Setting digit	Explanation	Initial value																								
___x	For manufacturer setting	0h																								
__x_		0h																								
_x__	Servo forced stop selection 0: Enabled (The forced stop input EM2 or EM1 is used.) 1: Disabled (The forced stop input EM2 and EM1 are not used.) Refer to table 5.1 for details.	0h																								
x___	Forced stop deceleration function selection 0: Forced stop deceleration function disabled (EM1 is used.) 2: Forced stop deceleration function enabled (EM2 is used.) Refer to table 5.1 for details.	2h																								
Table 5.1 Deceleration method																										
<table border="1"> <thead> <tr> <th rowspan="2">Setting value</th> <th rowspan="2">EM2/EM1</th> <th colspan="2">Deceleration method</th> </tr> <tr> <th>EM2 or EM1 is off.</th> <th>The controller forced stop is enabled or an alarm occurs.</th> </tr> </thead> <tbody> <tr> <td>00__</td> <td>EM1</td> <td>MBR (Electromagnetic brake interlock) turns off without the forced stop deceleration.</td> <td>MBR (Electromagnetic brake interlock) turns off without the forced stop deceleration.</td> </tr> <tr> <td>20__</td> <td>EM2</td> <td>MBR (Electromagnetic brake interlock) turns off after the forced stop deceleration.</td> <td>MBR (Electromagnetic brake interlock) turns off after the forced stop deceleration.</td> </tr> <tr> <td>01__</td> <td>Not using EM2 and EM1</td> <td style="text-align: center;">/</td> <td>MBR (Electromagnetic brake interlock) turns off without the forced stop deceleration.</td> </tr> <tr> <td>21__</td> <td>Not using EM2 and EM1</td> <td style="text-align: center;">/</td> <td>MBR (Electromagnetic brake interlock) turns off after the forced stop deceleration.</td> </tr> </tbody> </table>					Setting value	EM2/EM1	Deceleration method		EM2 or EM1 is off.	The controller forced stop is enabled or an alarm occurs.	00__	EM1	MBR (Electromagnetic brake interlock) turns off without the forced stop deceleration.	MBR (Electromagnetic brake interlock) turns off without the forced stop deceleration.	20__	EM2	MBR (Electromagnetic brake interlock) turns off after the forced stop deceleration.	MBR (Electromagnetic brake interlock) turns off after the forced stop deceleration.	01__	Not using EM2 and EM1	/	MBR (Electromagnetic brake interlock) turns off without the forced stop deceleration.	21__	Not using EM2 and EM1	/	MBR (Electromagnetic brake interlock) turns off after the forced stop deceleration.
Setting value	EM2/EM1	Deceleration method																								
		EM2 or EM1 is off.	The controller forced stop is enabled or an alarm occurs.																							
00__	EM1	MBR (Electromagnetic brake interlock) turns off without the forced stop deceleration.	MBR (Electromagnetic brake interlock) turns off without the forced stop deceleration.																							
20__	EM2	MBR (Electromagnetic brake interlock) turns off after the forced stop deceleration.	MBR (Electromagnetic brake interlock) turns off after the forced stop deceleration.																							
01__	Not using EM2 and EM1	/	MBR (Electromagnetic brake interlock) turns off without the forced stop deceleration.																							
21__	Not using EM2 and EM1	/	MBR (Electromagnetic brake interlock) turns off after the forced stop deceleration.																							

5. PARAMETERS

No.	Symbol	Name and function	Initial value [unit]	Setting range																		
PA08	ATU	Auto tuning mode Select the gain adjustment mode.		Refer to the "Name and function" column.																		
		<table border="1"> <thead> <tr> <th>Setting digit</th> <th>Explanation</th> <th>Initial value</th> </tr> </thead> <tbody> <tr> <td>___x</td> <td> Gain adjustment mode selection 0: 2 gain adjustment mode 1 (interpolation mode) 1: Auto tuning mode 1 2: Auto tuning mode 2 3: Manual mode 4: 2 gain adjustment mode 2 Refer to table 5.2 for details. </td> <td>1h</td> </tr> <tr> <td>__x_</td> <td rowspan="3">For manufacturer setting</td> <td>0h</td> </tr> <tr> <td>_x__</td> <td>0h</td> </tr> <tr> <td>x___</td> <td>0h</td> </tr> </tbody> </table>	Setting digit	Explanation	Initial value	___x	Gain adjustment mode selection 0: 2 gain adjustment mode 1 (interpolation mode) 1: Auto tuning mode 1 2: Auto tuning mode 2 3: Manual mode 4: 2 gain adjustment mode 2 Refer to table 5.2 for details.	1h	__x_	For manufacturer setting	0h	_x__	0h	x___	0h							
Setting digit	Explanation	Initial value																				
___x	Gain adjustment mode selection 0: 2 gain adjustment mode 1 (interpolation mode) 1: Auto tuning mode 1 2: Auto tuning mode 2 3: Manual mode 4: 2 gain adjustment mode 2 Refer to table 5.2 for details.	1h																				
__x_	For manufacturer setting	0h																				
_x__		0h																				
x___		0h																				
		Table 5.2 Gain adjustment mode selection																				
		<table border="1"> <thead> <tr> <th>Setting value</th> <th>Gain adjustment mode</th> <th>Automatically adjusted parameter</th> </tr> </thead> <tbody> <tr> <td>___0</td> <td>2 gain adjustment mode 1 (interpolation mode)</td> <td> [Pr. PB06 Load to motor inertia ratio] [Pr. PB08 Position loop gain] [Pr. PB09 Speed loop gain] [Pr. PB10 Speed integral compensation] </td> </tr> <tr> <td>___1</td> <td>Auto tuning mode 1</td> <td> [Pr. PB06 Load to motor inertia ratio] [Pr. PB07 Model loop gain] [Pr. PB08 Position loop gain] [Pr. PB09 Speed loop gain] [Pr. PB10 Speed integral compensation] </td> </tr> <tr> <td>___2</td> <td>Auto tuning mode 2</td> <td> [Pr. PB07 Model loop gain] [Pr. PB08 Position loop gain] [Pr. PB09 Speed loop gain] [Pr. PB10 Speed integral compensation] </td> </tr> <tr> <td>___3</td> <td>Manual mode</td> <td></td> </tr> <tr> <td>___4</td> <td>2 gain adjustment mode 2</td> <td> [Pr. PB08 Position loop gain] [Pr. PB09 Speed loop gain] [Pr. PB10 Speed integral compensation] </td> </tr> </tbody> </table>	Setting value	Gain adjustment mode	Automatically adjusted parameter	___0	2 gain adjustment mode 1 (interpolation mode)	[Pr. PB06 Load to motor inertia ratio] [Pr. PB08 Position loop gain] [Pr. PB09 Speed loop gain] [Pr. PB10 Speed integral compensation]	___1	Auto tuning mode 1	[Pr. PB06 Load to motor inertia ratio] [Pr. PB07 Model loop gain] [Pr. PB08 Position loop gain] [Pr. PB09 Speed loop gain] [Pr. PB10 Speed integral compensation]	___2	Auto tuning mode 2	[Pr. PB07 Model loop gain] [Pr. PB08 Position loop gain] [Pr. PB09 Speed loop gain] [Pr. PB10 Speed integral compensation]	___3	Manual mode		___4	2 gain adjustment mode 2	[Pr. PB08 Position loop gain] [Pr. PB09 Speed loop gain] [Pr. PB10 Speed integral compensation]		
Setting value	Gain adjustment mode	Automatically adjusted parameter																				
___0	2 gain adjustment mode 1 (interpolation mode)	[Pr. PB06 Load to motor inertia ratio] [Pr. PB08 Position loop gain] [Pr. PB09 Speed loop gain] [Pr. PB10 Speed integral compensation]																				
___1	Auto tuning mode 1	[Pr. PB06 Load to motor inertia ratio] [Pr. PB07 Model loop gain] [Pr. PB08 Position loop gain] [Pr. PB09 Speed loop gain] [Pr. PB10 Speed integral compensation]																				
___2	Auto tuning mode 2	[Pr. PB07 Model loop gain] [Pr. PB08 Position loop gain] [Pr. PB09 Speed loop gain] [Pr. PB10 Speed integral compensation]																				
___3	Manual mode																					
___4	2 gain adjustment mode 2	[Pr. PB08 Position loop gain] [Pr. PB09 Speed loop gain] [Pr. PB10 Speed integral compensation]																				

5. PARAMETERS

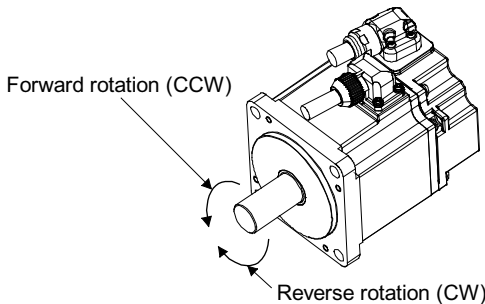
No.	Symbol	Name and function	Initial value [unit]	Setting range																																																																																														
PA09	RSP	Auto tuning response Set the auto tuning response. <table border="1" style="width: 100%; border-collapse: collapse; margin-top: 10px;"> <thead> <tr> <th rowspan="2">Setting value</th> <th colspan="2">Machine characteristic</th> <th rowspan="2">Setting value</th> <th colspan="2">Machine characteristic</th> </tr> <tr> <th>Response</th> <th>Guideline for machine resonance frequency [Hz]</th> <th>Response</th> <th>Guideline for machine resonance frequency [Hz]</th> </tr> </thead> <tbody> <tr><td>1</td><td rowspan="18" style="text-align: center; vertical-align: middle;">↑ Low response</td><td>2.7</td><td>21</td><td rowspan="18" style="text-align: center; vertical-align: middle;">↑ Middle response</td><td>67.1</td></tr> <tr><td>2</td><td>3.6</td><td>22</td><td>75.6</td></tr> <tr><td>3</td><td>4.9</td><td>23</td><td>85.2</td></tr> <tr><td>4</td><td>6.6</td><td>24</td><td>95.9</td></tr> <tr><td>5</td><td>10.0</td><td>25</td><td>108.0</td></tr> <tr><td>6</td><td>11.3</td><td>26</td><td>121.7</td></tr> <tr><td>7</td><td>12.7</td><td>27</td><td>137.1</td></tr> <tr><td>8</td><td>14.3</td><td>28</td><td>154.4</td></tr> <tr><td>9</td><td>16.1</td><td>29</td><td>173.9</td></tr> <tr><td>10</td><td>18.1</td><td>30</td><td>195.9</td></tr> <tr><td>11</td><td>20.4</td><td>31</td><td>220.6</td></tr> <tr><td>12</td><td>23.0</td><td>32</td><td>248.5</td></tr> <tr><td>13</td><td>25.9</td><td>33</td><td>279.9</td></tr> <tr><td>14</td><td>29.2</td><td>34</td><td>315.3</td></tr> <tr><td>15</td><td>32.9</td><td>35</td><td>355.1</td></tr> <tr><td>16</td><td>37.0</td><td>36</td><td>400.0</td></tr> <tr><td>17</td><td>41.7</td><td>37</td><td>446.6</td></tr> <tr><td>18</td><td>47.0</td><td>38</td><td>501.2</td></tr> <tr><td>19</td><td rowspan="2" style="text-align: center; vertical-align: middle;">↓ Middle response</td><td>52.9</td><td>39</td><td rowspan="2" style="text-align: center; vertical-align: middle;">↓ High response</td><td>571.5</td></tr> <tr><td>20</td><td>59.6</td><td>40</td><td>642.7</td></tr> </tbody> </table>	Setting value	Machine characteristic		Setting value	Machine characteristic		Response	Guideline for machine resonance frequency [Hz]	Response	Guideline for machine resonance frequency [Hz]	1	↑ Low response	2.7	21	↑ Middle response	67.1	2	3.6	22	75.6	3	4.9	23	85.2	4	6.6	24	95.9	5	10.0	25	108.0	6	11.3	26	121.7	7	12.7	27	137.1	8	14.3	28	154.4	9	16.1	29	173.9	10	18.1	30	195.9	11	20.4	31	220.6	12	23.0	32	248.5	13	25.9	33	279.9	14	29.2	34	315.3	15	32.9	35	355.1	16	37.0	36	400.0	17	41.7	37	446.6	18	47.0	38	501.2	19	↓ Middle response	52.9	39	↓ High response	571.5	20	59.6	40	642.7	16	1 to 40
Setting value	Machine characteristic			Setting value	Machine characteristic																																																																																													
	Response	Guideline for machine resonance frequency [Hz]	Response		Guideline for machine resonance frequency [Hz]																																																																																													
1	↑ Low response	2.7	21	↑ Middle response	67.1																																																																																													
2		3.6	22		75.6																																																																																													
3		4.9	23		85.2																																																																																													
4		6.6	24		95.9																																																																																													
5		10.0	25		108.0																																																																																													
6		11.3	26		121.7																																																																																													
7		12.7	27		137.1																																																																																													
8		14.3	28		154.4																																																																																													
9		16.1	29		173.9																																																																																													
10		18.1	30		195.9																																																																																													
11		20.4	31		220.6																																																																																													
12		23.0	32		248.5																																																																																													
13		25.9	33		279.9																																																																																													
14		29.2	34		315.3																																																																																													
15		32.9	35		355.1																																																																																													
16		37.0	36		400.0																																																																																													
17		41.7	37		446.6																																																																																													
18		47.0	38		501.2																																																																																													
19	↓ Middle response	52.9	39	↓ High response	571.5																																																																																													
20		59.6	40		642.7																																																																																													
PA10	INP	In-position range Set an in-position range per command pulse.	100 [pulse]	0 to 65535																																																																																														
PA14	*POL	Rotation direction selection Select the rotation direction of command input pulses. <table border="1" style="width: 100%; border-collapse: collapse; margin-top: 10px;"> <thead> <tr> <th rowspan="2">Setting value</th> <th colspan="2">Servo motor rotation direction</th> </tr> <tr> <th>Positioning address increase</th> <th>Positioning address decrease</th> </tr> </thead> <tbody> <tr> <td>0</td> <td>CCW</td> <td>CW</td> </tr> <tr> <td>1</td> <td>CW</td> <td>CCW</td> </tr> </tbody> </table> <p>The following shows the servo motor rotation directions.</p> 	Setting value	Servo motor rotation direction		Positioning address increase	Positioning address decrease	0	CCW	CW	1	CW	CCW	0	0 to 1																																																																																			
Setting value	Servo motor rotation direction																																																																																																	
	Positioning address increase	Positioning address decrease																																																																																																
0	CCW	CW																																																																																																
1	CW	CCW																																																																																																

5. PARAMETERS

No.	Symbol	Name and function	Initial value [unit]	Setting range			
PA19	*BLK	Parameter writing inhibit Select a reference range and writing range of parameters. Refer to table 5.3 for settings.	00AAh	Refer to the "Name and function" column.			
Table 5.3 [Pr. PA19] setting value and reading/writing range							
PA19	Setting operation	PA	PB	PC	PD	PE	PF
Other than below	Reading	○	/	/	/	/	/
	Writing	○	/	/	/	/	/
000Ah	Reading	Only 19	/	/	/	/	/
	Writing	Only 19	/	/	/	/	/
000Bh	Reading	○	○	○	/	/	/
	Writing	○	○	○	/	/	/
000Ch	Reading	○	○	○	○	/	/
	Writing	○	○	○	○	/	/
000Fh	Reading	○	○	○	○	○	/
	Writing	○	○	○	○	○	/
00AAh (initial value)	Reading	○	○	○	○	○	○
	Writing	○	○	○	○	○	○
100Bh	Reading	○	/	/	/	/	/
	Writing	Only 19	/	/	/	/	/
100Ch	Reading	○	○	○	○	/	/
	Writing	Only 19	/	/	/	/	/
100Fh	Reading	○	○	○	○	○	/
	Writing	Only 19	/	/	/	/	/
10AAh	Reading	○	○	○	○	○	○
	Writing	Only 19	/	/	/	/	/

5. PARAMETERS

No.	Symbol	Name and function	Initial value [unit]	Setting range															
PA20	*TDS	<p>Tough drive setting Alarms may not be avoided with the tough drive function depending on the situations of the power supply and load fluctuation. You can assign MTRR (During tough drive) to the CN3-13 pin with [Pr. PD07].</p> <table border="1"> <thead> <tr> <th>Setting digit</th> <th>Explanation</th> <th>Initial value</th> </tr> </thead> <tbody> <tr> <td>__ _ x</td> <td>For manufacturer setting</td> <td>0h</td> </tr> <tr> <td>_ _ x _</td> <td> <p>Vibration tough drive selection 0: Disabled 1: Enabled</p> <p>Selecting "1" suppresses vibrations by automatically changing setting values of [Pr. PB13 Machine resonance suppression filter 1] and [Pr. PB15 Machine resonance suppression filter 2] in case that the vibration exceeds the value of the oscillation level set in [Pr. PF23]. Refer to section 7.3 for details.</p> </td> <td>0h</td> </tr> <tr> <td>_ x _ _</td> <td> <p>Instantaneous power failure tough drive selection 0: Disabled 1: Enabled</p> <p>Selecting "1" avoids triggering [AL. 10 Undervoltage] using the electrical energy charged in the capacitor in case that an instantaneous power failure occurs during operation. In [Pr. PF25 Instantaneous power failure tough drive - Detection time], set the time until the occurrence of [AL. 10.1 Voltage drop in the power]. When "1" is selected for this digit, the power should be off for the setting value of [Pr. PF25] + 1 s or longer before the power is cycled to enable a parameter whose symbol is preceded by "*" or "***".</p> </td> <td>0h</td> </tr> <tr> <td>x _ _ _</td> <td>For manufacturer setting</td> <td>0h</td> </tr> </tbody> </table>	Setting digit	Explanation	Initial value	__ _ x	For manufacturer setting	0h	_ _ x _	<p>Vibration tough drive selection 0: Disabled 1: Enabled</p> <p>Selecting "1" suppresses vibrations by automatically changing setting values of [Pr. PB13 Machine resonance suppression filter 1] and [Pr. PB15 Machine resonance suppression filter 2] in case that the vibration exceeds the value of the oscillation level set in [Pr. PF23]. Refer to section 7.3 for details.</p>	0h	_ x _ _	<p>Instantaneous power failure tough drive selection 0: Disabled 1: Enabled</p> <p>Selecting "1" avoids triggering [AL. 10 Undervoltage] using the electrical energy charged in the capacitor in case that an instantaneous power failure occurs during operation. In [Pr. PF25 Instantaneous power failure tough drive - Detection time], set the time until the occurrence of [AL. 10.1 Voltage drop in the power]. When "1" is selected for this digit, the power should be off for the setting value of [Pr. PF25] + 1 s or longer before the power is cycled to enable a parameter whose symbol is preceded by "*" or "***".</p>	0h	x _ _ _	For manufacturer setting	0h	Refer to the "Name and function" column.	
Setting digit	Explanation	Initial value																	
__ _ x	For manufacturer setting	0h																	
_ _ x _	<p>Vibration tough drive selection 0: Disabled 1: Enabled</p> <p>Selecting "1" suppresses vibrations by automatically changing setting values of [Pr. PB13 Machine resonance suppression filter 1] and [Pr. PB15 Machine resonance suppression filter 2] in case that the vibration exceeds the value of the oscillation level set in [Pr. PF23]. Refer to section 7.3 for details.</p>	0h																	
_ x _ _	<p>Instantaneous power failure tough drive selection 0: Disabled 1: Enabled</p> <p>Selecting "1" avoids triggering [AL. 10 Undervoltage] using the electrical energy charged in the capacitor in case that an instantaneous power failure occurs during operation. In [Pr. PF25 Instantaneous power failure tough drive - Detection time], set the time until the occurrence of [AL. 10.1 Voltage drop in the power]. When "1" is selected for this digit, the power should be off for the setting value of [Pr. PF25] + 1 s or longer before the power is cycled to enable a parameter whose symbol is preceded by "*" or "***".</p>	0h																	
x _ _ _	For manufacturer setting	0h																	
PA21	*AOP3	<p>Function selection A-3</p> <table border="1"> <thead> <tr> <th>Setting digit</th> <th>Explanation</th> <th>Initial value</th> </tr> </thead> <tbody> <tr> <td>_ _ _ x</td> <td> <p>One-touch tuning function selection 0: Disabled 1: Enabled</p> <p>When the digit is "0", the one-touch tuning with MR Configurator2 will be disabled.</p> </td> <td>1h</td> </tr> <tr> <td>_ _ x _</td> <td rowspan="3">For manufacturer setting</td> <td>0h</td> </tr> <tr> <td>_ x _ _</td> <td>0h</td> </tr> <tr> <td>x _ _ _</td> <td>0h</td> </tr> </tbody> </table>	Setting digit	Explanation	Initial value	_ _ _ x	<p>One-touch tuning function selection 0: Disabled 1: Enabled</p> <p>When the digit is "0", the one-touch tuning with MR Configurator2 will be disabled.</p>	1h	_ _ x _	For manufacturer setting	0h	_ x _ _	0h	x _ _ _	0h	Refer to the "Name and function" column.			
Setting digit	Explanation	Initial value																	
_ _ _ x	<p>One-touch tuning function selection 0: Disabled 1: Enabled</p> <p>When the digit is "0", the one-touch tuning with MR Configurator2 will be disabled.</p>	1h																	
_ _ x _	For manufacturer setting	0h																	
_ x _ _		0h																	
x _ _ _		0h																	

5. PARAMETERS

No.	Symbol	Name and function	Initial value [unit]	Setting range											
PA23	DRAT	Drive recorder arbitrary alarm trigger setting		Refer to the "Name and function" column.											
		<table border="1"> <thead> <tr> <th>Setting digit</th> <th>Explanation</th> <th>Initial value</th> </tr> </thead> <tbody> <tr> <td>_ _ x x</td> <td>Alarm detail No. setting Set the digits when you execute the trigger with an arbitrary alarm detail No. for the drive recorder function. When these digits are "0 0", only the arbitrary alarm No. setting will be enabled.</td> <td>00h</td> </tr> <tr> <td>x x _ _</td> <td>Alarm No. setting Set the digits when you execute the trigger with an arbitrary alarm No. for the drive recorder function. When "0 0" are set, the arbitrary alarm trigger of the drive recorder will be disabled.</td> <td>00h</td> </tr> </tbody> </table> <p>Setting example: To activate the drive recorder when [AL. 50 Overload 1] occurs, set "5 0 0 0". To activate the drive recorder when [AL. 50.3 Thermal overload error 4 during operation] occurs, set "5 0 0 3".</p>	Setting digit		Explanation	Initial value	_ _ x x	Alarm detail No. setting Set the digits when you execute the trigger with an arbitrary alarm detail No. for the drive recorder function. When these digits are "0 0", only the arbitrary alarm No. setting will be enabled.	00h	x x _ _	Alarm No. setting Set the digits when you execute the trigger with an arbitrary alarm No. for the drive recorder function. When "0 0" are set, the arbitrary alarm trigger of the drive recorder will be disabled.	00h			
Setting digit	Explanation	Initial value													
_ _ x x	Alarm detail No. setting Set the digits when you execute the trigger with an arbitrary alarm detail No. for the drive recorder function. When these digits are "0 0", only the arbitrary alarm No. setting will be enabled.	00h													
x x _ _	Alarm No. setting Set the digits when you execute the trigger with an arbitrary alarm No. for the drive recorder function. When "0 0" are set, the arbitrary alarm trigger of the drive recorder will be disabled.	00h													
PA24	AOP4	Function selection A-4		Refer to the "Name and function" column.											
		<table border="1"> <thead> <tr> <th>Setting digit</th> <th>Explanation</th> <th>Initial value</th> </tr> </thead> <tbody> <tr> <td>_ _ _ x</td> <td>Vibration suppression mode selection 0: Standard mode 1: 3 inertia mode 2: Low response mode When two low resonance frequencies are generated, select "3 inertia mode (_ _ _ 1)". When the load to motor inertia ratio exceeds the recommended load to motor inertia ratio, select "Low response mode (_ _ _ 2)". When you select the standard mode or low response mode, "Vibration suppression control 2" cannot be used. When you select the 3 inertia mode, the feed forward gain cannot be used. Before changing the control mode with the controller during the 3 inertia mode or low response mode, stop the motor.</td> <td>0h</td> </tr> <tr> <td>_ _ x _</td> <td rowspan="3">For manufacturer setting</td> <td>0h</td> </tr> <tr> <td>_ x _ _</td> <td>0h</td> </tr> <tr> <td>x _ _ _</td> <td>0h</td> </tr> </tbody> </table>	Setting digit		Explanation	Initial value	_ _ _ x	Vibration suppression mode selection 0: Standard mode 1: 3 inertia mode 2: Low response mode When two low resonance frequencies are generated, select "3 inertia mode (_ _ _ 1)". When the load to motor inertia ratio exceeds the recommended load to motor inertia ratio, select "Low response mode (_ _ _ 2)". When you select the standard mode or low response mode, "Vibration suppression control 2" cannot be used. When you select the 3 inertia mode, the feed forward gain cannot be used. Before changing the control mode with the controller during the 3 inertia mode or low response mode, stop the motor.	0h	_ _ x _	For manufacturer setting	0h	_ x _ _	0h	x _ _ _
Setting digit	Explanation	Initial value													
_ _ _ x	Vibration suppression mode selection 0: Standard mode 1: 3 inertia mode 2: Low response mode When two low resonance frequencies are generated, select "3 inertia mode (_ _ _ 1)". When the load to motor inertia ratio exceeds the recommended load to motor inertia ratio, select "Low response mode (_ _ _ 2)". When you select the standard mode or low response mode, "Vibration suppression control 2" cannot be used. When you select the 3 inertia mode, the feed forward gain cannot be used. Before changing the control mode with the controller during the 3 inertia mode or low response mode, stop the motor.	0h													
_ _ x _	For manufacturer setting	0h													
_ x _ _		0h													
x _ _ _		0h													

5. PARAMETERS

No.	Symbol	Name and function	Initial value [unit]	Setting range													
PA25	OTHOV	One-touch tuning - Overshoot permissible level Set a permissible value of the overshoot amount for one-touch tuning as a percentage of the in-position range. However, setting "0" will be 50%.	0 [%]	0 to 100													
PA26	*AOP5	Function selection A-5 <table border="1" style="width: 100%; border-collapse: collapse;"> <thead> <tr> <th style="width: 15%;">Setting digit</th> <th style="width: 65%;">Explanation</th> <th style="width: 20%;">Initial value</th> </tr> </thead> <tbody> <tr> <td>___x</td> <td>Torque limit function selection at instantaneous power failure (instantaneous power failure tough drive selection) 0: Disabled 1: Enabled When an instantaneous power failure occurs during operation, you can save electric energy charged in the capacitor in the servo amplifier by limiting torque at acceleration. You can also delay the time until the occurrence of [AL. 10.2 Bus voltage drop] with the instantaneous power failure tough drive function. Doing this will enable you to set a longer time in [Pr. PF25 Instantaneous power failure tough drive - Detection time]. The torque limit function at instantaneous power failure is enabled when "instantaneous power failure tough drive selection" in [Pr. PA20] is "Enabled (_ 1 _)".</td> <td>0h</td> </tr> <tr> <td>__x_</td> <td rowspan="4">For manufacturer setting</td> <td>0h</td> </tr> <tr> <td>_x__</td> <td>0h</td> </tr> <tr> <td>x___</td> <td>0h</td> </tr> </tbody> </table>	Setting digit	Explanation	Initial value	___x	Torque limit function selection at instantaneous power failure (instantaneous power failure tough drive selection) 0: Disabled 1: Enabled When an instantaneous power failure occurs during operation, you can save electric energy charged in the capacitor in the servo amplifier by limiting torque at acceleration. You can also delay the time until the occurrence of [AL. 10.2 Bus voltage drop] with the instantaneous power failure tough drive function. Doing this will enable you to set a longer time in [Pr. PF25 Instantaneous power failure tough drive - Detection time]. The torque limit function at instantaneous power failure is enabled when "instantaneous power failure tough drive selection" in [Pr. PA20] is "Enabled (_ 1 _)".	0h	__x_	For manufacturer setting	0h	_x__	0h	x___	0h	Refer to the "Name and function" column.	
Setting digit	Explanation	Initial value															
___x	Torque limit function selection at instantaneous power failure (instantaneous power failure tough drive selection) 0: Disabled 1: Enabled When an instantaneous power failure occurs during operation, you can save electric energy charged in the capacitor in the servo amplifier by limiting torque at acceleration. You can also delay the time until the occurrence of [AL. 10.2 Bus voltage drop] with the instantaneous power failure tough drive function. Doing this will enable you to set a longer time in [Pr. PF25 Instantaneous power failure tough drive - Detection time]. The torque limit function at instantaneous power failure is enabled when "instantaneous power failure tough drive selection" in [Pr. PA20] is "Enabled (_ 1 _)".	0h															
__x_	For manufacturer setting	0h															
_x__		0h															
x___		0h															
PA27		*HTL	Hot line forced stop function <table border="1" style="width: 100%; border-collapse: collapse;"> <thead> <tr> <th style="width: 15%;">Setting digit</th> <th style="width: 65%;">Explanation</th> <th style="width: 20%;">Initial value</th> </tr> </thead> <tbody> <tr> <td>___x</td> <td>Hot line forced stop function selection 0: Enabled 1: Disabled</td> <td>0h</td> </tr> <tr> <td>__x_</td> <td rowspan="4">For manufacturer setting</td> <td>0h</td> </tr> <tr> <td>_x__</td> <td>0h</td> </tr> <tr> <td>x___</td> <td>0h</td> </tr> </tbody> </table>	Setting digit	Explanation	Initial value	___x	Hot line forced stop function selection 0: Enabled 1: Disabled	0h	__x_	For manufacturer setting	0h	_x__	0h	x___	0h	Refer to the "Name and function" column.
Setting digit	Explanation	Initial value															
___x	Hot line forced stop function selection 0: Enabled 1: Disabled	0h															
__x_	For manufacturer setting	0h															
_x__		0h															
x___		0h															
PA28		**AOP6	Function selection A-6 <table border="1" style="width: 100%; border-collapse: collapse;"> <thead> <tr> <th style="width: 15%;">Setting digit</th> <th style="width: 65%;">Explanation</th> <th style="width: 20%;">Initial value</th> </tr> </thead> <tbody> <tr> <td>___x</td> <td>Selection of the HG-KN series servo motor maximum speed Select the maximum speed of the HG-KN series servo motor. 0: A maximum speed of 5000 r/min 1: A maximum speed of 6000 r/min This digit is disabled when a servo motor other than HG-KN series is connected. This digit is available with servo amplifier with software version C4 or later.</td> <td>0h</td> </tr> <tr> <td>__x_</td> <td rowspan="3">For manufacturer setting</td> <td>0h</td> </tr> <tr> <td>_x__</td> <td>0h</td> </tr> <tr> <td>x___</td> <td>0h</td> </tr> </tbody> </table>	Setting digit	Explanation	Initial value	___x	Selection of the HG-KN series servo motor maximum speed Select the maximum speed of the HG-KN series servo motor. 0: A maximum speed of 5000 r/min 1: A maximum speed of 6000 r/min This digit is disabled when a servo motor other than HG-KN series is connected. This digit is available with servo amplifier with software version C4 or later.	0h	__x_	For manufacturer setting	0h	_x__	0h	x___	0h	Refer to the "Name and function" column.
Setting digit	Explanation	Initial value															
___x	Selection of the HG-KN series servo motor maximum speed Select the maximum speed of the HG-KN series servo motor. 0: A maximum speed of 5000 r/min 1: A maximum speed of 6000 r/min This digit is disabled when a servo motor other than HG-KN series is connected. This digit is available with servo amplifier with software version C4 or later.	0h															
__x_	For manufacturer setting	0h															
_x__		0h															
x___		0h															

5. PARAMETERS

5.2.2 Gain/filter setting parameters ([Pr. PB_ _])

No.	Symbol	Name and function	Initial value [unit]	Setting range														
PB01	FILT	Adaptive tuning mode (adaptive filter II) Set the adaptive tuning.	Refer to the "Name and function" column.															
		<table border="1"> <thead> <tr> <th>Setting digit</th> <th>Explanation</th> <th>Initial value</th> </tr> </thead> <tbody> <tr> <td>___x</td> <td>Filter tuning mode selection Select the adjustment mode of the machine resonance suppression filter 1. Refer to section 7.1.2 for details. 0: Disabled 1: Automatic setting 2: Manual setting</td> <td>0h</td> </tr> <tr> <td>__x_</td> <td rowspan="2">For manufacturer setting</td> <td>0h</td> </tr> <tr> <td>_x__</td> <td>0h</td> </tr> <tr> <td>x___</td> <td>Tuning accuracy selection 0: Standard 1: High accuracy The frequency is estimated more accurately in the high accuracy mode compared to the standard mode. However, the tuning sound may be larger in the high accuracy mode. This digit is available with servo amplifier with software version C5 or later.</td> <td>0h</td> </tr> </tbody> </table>			Setting digit	Explanation	Initial value	___x	Filter tuning mode selection Select the adjustment mode of the machine resonance suppression filter 1. Refer to section 7.1.2 for details. 0: Disabled 1: Automatic setting 2: Manual setting	0h	__x_	For manufacturer setting	0h	_x__	0h	x___	Tuning accuracy selection 0: Standard 1: High accuracy The frequency is estimated more accurately in the high accuracy mode compared to the standard mode. However, the tuning sound may be larger in the high accuracy mode. This digit is available with servo amplifier with software version C5 or later.	0h
		Setting digit			Explanation	Initial value												
		___x			Filter tuning mode selection Select the adjustment mode of the machine resonance suppression filter 1. Refer to section 7.1.2 for details. 0: Disabled 1: Automatic setting 2: Manual setting	0h												
		__x_			For manufacturer setting	0h												
_x__	0h																	
x___	Tuning accuracy selection 0: Standard 1: High accuracy The frequency is estimated more accurately in the high accuracy mode compared to the standard mode. However, the tuning sound may be larger in the high accuracy mode. This digit is available with servo amplifier with software version C5 or later.	0h																
PB02	VRFT	Vibration suppression control tuning mode (advanced vibration suppression control II) Set the vibration suppression control tuning. Refer to section 7.1.5 for details.	Refer to the "Name and function" column.															
		<table border="1"> <thead> <tr> <th>Setting digit</th> <th>Explanation</th> <th>Initial value</th> </tr> </thead> <tbody> <tr> <td>___x</td> <td>Vibration suppression control 1 tuning mode selection Select the tuning mode of the vibration suppression control 1. 0: Disabled 1: Automatic setting 2: Manual setting</td> <td>0h</td> </tr> <tr> <td>__x_</td> <td>Vibration suppression control 2 tuning mode selection Select the tuning mode of the vibration suppression control 2. To enable the digit, select "3 inertia mode (___1)" of "Vibration suppression mode selection" in [Pr. PA24 Function selection A-4]. 0: Disabled 1: Automatic setting 2: Manual setting</td> <td>0h</td> </tr> <tr> <td>_x__</td> <td rowspan="2">For manufacturer setting</td> <td>0h</td> </tr> <tr> <td>x___</td> <td>0h</td> </tr> </tbody> </table>			Setting digit	Explanation	Initial value	___x	Vibration suppression control 1 tuning mode selection Select the tuning mode of the vibration suppression control 1. 0: Disabled 1: Automatic setting 2: Manual setting	0h	__x_	Vibration suppression control 2 tuning mode selection Select the tuning mode of the vibration suppression control 2. To enable the digit, select "3 inertia mode (___1)" of "Vibration suppression mode selection" in [Pr. PA24 Function selection A-4]. 0: Disabled 1: Automatic setting 2: Manual setting	0h	_x__	For manufacturer setting	0h	x___	0h
		Setting digit			Explanation	Initial value												
		___x			Vibration suppression control 1 tuning mode selection Select the tuning mode of the vibration suppression control 1. 0: Disabled 1: Automatic setting 2: Manual setting	0h												
		__x_			Vibration suppression control 2 tuning mode selection Select the tuning mode of the vibration suppression control 2. To enable the digit, select "3 inertia mode (___1)" of "Vibration suppression mode selection" in [Pr. PA24 Function selection A-4]. 0: Disabled 1: Automatic setting 2: Manual setting	0h												
_x__	For manufacturer setting	0h																
x___		0h																
PB03	TFBGN	Torque feedback loop gain Set a torque feedback loop gain in the continuous operation to torque control mode. Decreasing the setting value will also decrease a collision load during continuous operation to torque control mode. If the servo motor speed or torque fluctuates when a workpiece comes into contact with a target object, decrease the setting value. Decreasing the setting value will help suppress fluctuation in servo motor speed or torque when a workpiece comes into contact with a target object. However, doing so will decrease trackability to the command torque. Setting a value of 6 rad/s or smaller will apply 6 rad/s.	18000 [rad/s]	0 to 18000														
PB04	FFC	Feed forward gain Set the feed forward gain. When the setting is 100%, the droop pulses during operation at constant speed are nearly zero. However, sudden acceleration/deceleration will increase the overshoot. As a guideline, when the feed forward gain setting is 100%, set 1 s or longer as the acceleration time constant up to the rated speed.	0 [%]	0 to 100														

5. PARAMETERS

No.	Symbol	Name and function	Initial value [unit]	Setting range										
PB06	GD2	<p>Load to motor inertia ratio Set the load to motor inertia ratio.</p> <p>Setting a value considerably different from the actual load moment of inertia may cause an unexpected operation such as an overshoot.</p> <p>The setting of this parameter will be the automatic setting or manual setting depending on the value set in [Pr. PA08]. Refer to the following table for details. When the parameter is automatic setting, the value will vary between 0.00 and 100.00.</p> <table border="1" style="margin-left: auto; margin-right: auto;"> <thead> <tr> <th>Pr. PA08</th> <th>This parameter</th> </tr> </thead> <tbody> <tr> <td>___ 0 (2 gain adjustment mode 1 (interpolation mode))</td> <td rowspan="2">Automatic setting</td> </tr> <tr> <td>___ 1 (Auto tuning mode 1)</td> </tr> <tr> <td>___ 2 (Auto tuning mode 2)</td> <td rowspan="3">Manual setting</td> </tr> <tr> <td>___ 3 (Manual mode)</td> </tr> <tr> <td>___ 4 (2 gain adjustment mode 2)</td> </tr> </tbody> </table>	Pr. PA08	This parameter	___ 0 (2 gain adjustment mode 1 (interpolation mode))	Automatic setting	___ 1 (Auto tuning mode 1)	___ 2 (Auto tuning mode 2)	Manual setting	___ 3 (Manual mode)	___ 4 (2 gain adjustment mode 2)	7.00 [Multiplier]	0.00 to 300.00	
Pr. PA08	This parameter													
___ 0 (2 gain adjustment mode 1 (interpolation mode))	Automatic setting													
___ 1 (Auto tuning mode 1)														
___ 2 (Auto tuning mode 2)	Manual setting													
___ 3 (Manual mode)														
___ 4 (2 gain adjustment mode 2)														
PB07	PG1	<p>Model loop gain Set the response gain up to the target position.</p> <p>Increasing the setting value will also increase the response level to the position command but will be liable to generate vibration and noise. For the vibration suppression control tuning mode, the setting range of [Pr. PB07] is limited. Refer to section 7.1.5 (4) for details.</p> <p>The setting of this parameter will be the automatic setting or manual setting depending on the value set in [Pr. PA08]. Refer to the following table for details.</p> <table border="1" style="margin-left: auto; margin-right: auto;"> <thead> <tr> <th>Pr. PA08</th> <th>This parameter</th> </tr> </thead> <tbody> <tr> <td>___ 0 (2 gain adjustment mode 1 (interpolation mode))</td> <td>Manual setting</td> </tr> <tr> <td>___ 1 (Auto tuning mode 1)</td> <td rowspan="2">Automatic setting</td> </tr> <tr> <td>___ 2 (Auto tuning mode 2)</td> </tr> <tr> <td>___ 3 (Manual mode)</td> <td rowspan="2">Manual setting</td> </tr> <tr> <td>___ 4 (2 gain adjustment mode 2)</td> </tr> </tbody> </table>	Pr. PA08	This parameter	___ 0 (2 gain adjustment mode 1 (interpolation mode))	Manual setting	___ 1 (Auto tuning mode 1)	Automatic setting	___ 2 (Auto tuning mode 2)	___ 3 (Manual mode)	Manual setting	___ 4 (2 gain adjustment mode 2)	15.0 [rad/s]	1.0 to 2000.0
Pr. PA08	This parameter													
___ 0 (2 gain adjustment mode 1 (interpolation mode))	Manual setting													
___ 1 (Auto tuning mode 1)	Automatic setting													
___ 2 (Auto tuning mode 2)														
___ 3 (Manual mode)	Manual setting													
___ 4 (2 gain adjustment mode 2)														
PB08	PG2	<p>Position loop gain Set the gain of the position loop.</p> <p>Set this parameter to increase the position response to load disturbance.</p> <p>Increasing the setting value will also increase the response level to the load disturbance but will be liable to generate vibration and noise.</p> <p>The setting of this parameter will be the automatic setting or manual setting depending on the value set in [Pr. PA08]. Refer to the following table for details.</p> <table border="1" style="margin-left: auto; margin-right: auto;"> <thead> <tr> <th>Pr. PA08</th> <th>This parameter</th> </tr> </thead> <tbody> <tr> <td>___ 0 (2 gain adjustment mode 1 (interpolation mode))</td> <td rowspan="3">Automatic setting</td> </tr> <tr> <td>___ 1 (Auto tuning mode 1)</td> </tr> <tr> <td>___ 2 (Auto tuning mode 2)</td> </tr> <tr> <td>___ 3 (Manual mode)</td> <td>Manual setting</td> </tr> <tr> <td>___ 4 (2 gain adjustment mode 2)</td> <td>Automatic setting</td> </tr> </tbody> </table>	Pr. PA08	This parameter	___ 0 (2 gain adjustment mode 1 (interpolation mode))	Automatic setting	___ 1 (Auto tuning mode 1)	___ 2 (Auto tuning mode 2)	___ 3 (Manual mode)	Manual setting	___ 4 (2 gain adjustment mode 2)	Automatic setting	37.0 [rad/s]	1.0 to 2000.0
Pr. PA08	This parameter													
___ 0 (2 gain adjustment mode 1 (interpolation mode))	Automatic setting													
___ 1 (Auto tuning mode 1)														
___ 2 (Auto tuning mode 2)														
___ 3 (Manual mode)	Manual setting													
___ 4 (2 gain adjustment mode 2)	Automatic setting													
PB09	VG2	<p>Speed loop gain Set the gain of the speed loop.</p> <p>Set this parameter when vibration occurs on machines having low rigidity or large backlash.</p> <p>Increasing the setting value will also increase the response level but will be liable to generate vibration and noise.</p> <p>The setting of this parameter will be the automatic setting or manual setting depending on the value set in [Pr. PA08]. Refer to the table of [Pr. PB08] for details.</p> <p>In the continuous operation to torque control mode, if the value of this parameter is smaller than the initial value, it may not be possible to follow the command torque.</p>	823 [rad/s]	20 to 65535										

5. PARAMETERS

No.	Symbol	Name and function	Initial value [unit]	Setting range													
PB10	VIC	Speed integral compensation Set the integral time constant of the speed loop. Decreasing the setting value will increase the response level but will be liable to generate vibration and noise. The setting of this parameter will be the automatic setting or manual setting depending on the value set in [Pr. PA08]. Refer to the table of [Pr. PB08] for details.	33.7 [ms]	0.1 to 1000.0													
PB11	VDC	Speed differential compensation Set the differential compensation. To enable the parameter, select "Continuous PID control enabled (_ _ 3 _)" of "PI-PID switching control selection" in [Pr. PB24].	980	0 to 1000													
PB12	OVA	Overshoot amount compensation Set a dynamic friction torque in percentage to the rated torque at servo motor rated speed. When the response level is low, or when the torque is limited, the efficiency of the parameter can be lower.	0 [%]	0 to 100													
PB13	NH1	Machine resonance suppression filter 1 Set the notch frequency of the machine resonance suppression filter 1. When "Filter tuning mode selection" is set to "Automatic setting (_ _ _ 1)" in [Pr. PB01], this parameter will be adjusted automatically by adaptive tuning. When "Filter tuning mode selection" is set to "Manual setting (_ _ _ 2)" in [Pr. PB01], the setting value will be enabled.	4500 [Hz]	10 to 4500													
PB14	NHQ1	Notch shape selection 1 Set forms of the machine resonance suppression filter 1. When "Filter tuning mode selection" is set to "Automatic setting (_ _ _ 1)" in [Pr. PB01], this parameter will be adjusted automatically by adaptive tuning. To enable the setting value, select the manual setting.	Refer to the "Name and function" column.														
		<table border="1"> <thead> <tr> <th>Setting digit</th> <th>Explanation</th> <th>Initial value</th> </tr> </thead> <tbody> <tr> <td>_ _ _ x</td> <td>For manufacturer setting</td> <td>0h</td> </tr> <tr> <td>_ _ x _</td> <td>Notch depth selection 0: -40 dB 1: -14 dB 2: -8 dB 3: -4 dB</td> <td>0h</td> </tr> <tr> <td>_ x _ _</td> <td>Notch width selection 0: ± = 2 1: ± = 3 2: ± = 4 3: ± = 5</td> <td>0h</td> </tr> <tr> <td>x _ _ _</td> <td>For manufacturer setting</td> <td>0h</td> </tr> </tbody> </table>			Setting digit	Explanation	Initial value	_ _ _ x	For manufacturer setting	0h	_ _ x _	Notch depth selection 0: -40 dB 1: -14 dB 2: -8 dB 3: -4 dB	0h	_ x _ _	Notch width selection 0: ± = 2 1: ± = 3 2: ± = 4 3: ± = 5	0h	x _ _ _
Setting digit	Explanation	Initial value															
_ _ _ x	For manufacturer setting	0h															
_ _ x _	Notch depth selection 0: -40 dB 1: -14 dB 2: -8 dB 3: -4 dB	0h															
_ x _ _	Notch width selection 0: ± = 2 1: ± = 3 2: ± = 4 3: ± = 5	0h															
x _ _ _	For manufacturer setting	0h															
PB15	NH2	Machine resonance suppression filter 2 Set the notch frequency of the machine resonance suppression filter 2. To enable the setting value, select "Enabled (_ _ _ 1)" of "Machine resonance suppression filter 2 selection" in [Pr. PB16].	4500 [Hz]	10 to 4500													

5. PARAMETERS

No.	Symbol	Name and function	Initial value [unit]	Setting range															
PB16	NHQ2	Notch shape selection 2 Set forms of the machine resonance suppression filter 2.	0h	Refer to the "Name and function" column.															
		<table border="1"> <thead> <tr> <th>Setting digit</th> <th>Explanation</th> <th>Initial value</th> </tr> </thead> <tbody> <tr> <td>___x</td> <td>Machine resonance suppression filter 2 selection 0: Disabled 1: Enabled</td> <td>0h</td> </tr> <tr> <td>__x_</td> <td>Notch depth selection 0: -40 dB 1: -14 dB 2: -8 dB 3: -4 dB</td> <td>0h</td> </tr> <tr> <td>_x__</td> <td>Notch width selection 0: ± = 2 1: ± = 3 2: ± = 4 3: ± = 5</td> <td>0h</td> </tr> <tr> <td>x___</td> <td>For manufacturer setting</td> <td>0h</td> </tr> </tbody> </table>			Setting digit	Explanation	Initial value	___x	Machine resonance suppression filter 2 selection 0: Disabled 1: Enabled	0h	__x_	Notch depth selection 0: -40 dB 1: -14 dB 2: -8 dB 3: -4 dB	0h	_x__	Notch width selection 0: ± = 2 1: ± = 3 2: ± = 4 3: ± = 5	0h	x___	For manufacturer setting	0h
		Setting digit			Explanation	Initial value													
		___x			Machine resonance suppression filter 2 selection 0: Disabled 1: Enabled	0h													
		__x_			Notch depth selection 0: -40 dB 1: -14 dB 2: -8 dB 3: -4 dB	0h													
_x__	Notch width selection 0: ± = 2 1: ± = 3 2: ± = 4 3: ± = 5	0h																	
x___	For manufacturer setting	0h																	

5. PARAMETERS

No.	Symbol	Name and function	Initial value [unit]	Setting range																																																																																
PB17	NHF	<p>Shaft resonance suppression filter Set the shaft resonance suppression filter. Use this parameter to suppress a low-frequency machine vibration. When you select "Automatic setting (_ _ _ 0)" of "Shaft resonance suppression filter selection" in [Pr. PB23], the value will be calculated automatically from the servo motor you use and load to motor inertia ratio. When "Manual setting (_ _ _ 1)" is selected, the setting written to the parameter is used. When "Shaft resonance suppression filter selection" is "Disabled (_ _ _ 2)" in [Pr. PB23], the setting value of this parameter will be disabled. When you select "Enabled (_ _ _ 1)" of "Machine resonance suppression filter 4 selection" in [Pr. PB49], the shaft resonance suppression filter cannot be used.</p> <table border="1"> <thead> <tr> <th>Setting digit</th> <th>Explanation</th> <th>Initial value</th> </tr> </thead> <tbody> <tr> <td>_ _ x x</td> <td>Shaft resonance suppression filter setting frequency selection Set the shaft resonance suppression filter. Refer to table 5.4 for settings. Set the value closest to the frequency you need.</td> <td>00h</td> </tr> <tr> <td>_ x _ _</td> <td>Notch depth selection 0: -40 dB 1: -14 dB 2: -8 dB 3: -4 dB</td> <td>0h</td> </tr> <tr> <td>x _ _ _</td> <td>For manufacturer setting</td> <td>0h</td> </tr> </tbody> </table> <p style="text-align: center;">Table 5.4 Shaft resonance suppression filter setting frequency selection</p> <table border="1"> <thead> <tr> <th>Setting value</th> <th>Frequency [Hz]</th> <th>Setting value</th> <th>Frequency [Hz]</th> </tr> </thead> <tbody> <tr><td>_ _ 0 0</td><td>Disabled</td><td>_ _ 1 0</td><td>562</td></tr> <tr><td>_ _ 0 1</td><td>Disabled</td><td>_ _ 1 1</td><td>529</td></tr> <tr><td>_ _ 0 2</td><td>4500</td><td>_ _ 1 2</td><td>500</td></tr> <tr><td>_ _ 0 3</td><td>3000</td><td>_ _ 1 3</td><td>473</td></tr> <tr><td>_ _ 0 4</td><td>2250</td><td>_ _ 1 4</td><td>450</td></tr> <tr><td>_ _ 0 5</td><td>1800</td><td>_ _ 1 5</td><td>428</td></tr> <tr><td>_ _ 0 6</td><td>1500</td><td>_ _ 1 6</td><td>409</td></tr> <tr><td>_ _ 0 7</td><td>1285</td><td>_ _ 1 7</td><td>391</td></tr> <tr><td>_ _ 0 8</td><td>1125</td><td>_ _ 1 8</td><td>375</td></tr> <tr><td>_ _ 0 9</td><td>1000</td><td>_ _ 1 9</td><td>360</td></tr> <tr><td>_ _ 0 A</td><td>900</td><td>_ _ 1 A</td><td>346</td></tr> <tr><td>_ _ 0 B</td><td>818</td><td>_ _ 1 B</td><td>333</td></tr> <tr><td>_ _ 0 C</td><td>750</td><td>_ _ 1 C</td><td>321</td></tr> <tr><td>_ _ 0 D</td><td>692</td><td>_ _ 1 D</td><td>310</td></tr> <tr><td>_ _ 0 E</td><td>642</td><td>_ _ 1 E</td><td>300</td></tr> <tr><td>_ _ 0 F</td><td>600</td><td>_ _ 1 F</td><td>290</td></tr> </tbody> </table>	Setting digit	Explanation	Initial value	_ _ x x	Shaft resonance suppression filter setting frequency selection Set the shaft resonance suppression filter. Refer to table 5.4 for settings. Set the value closest to the frequency you need.	00h	_ x _ _	Notch depth selection 0: -40 dB 1: -14 dB 2: -8 dB 3: -4 dB	0h	x _ _ _	For manufacturer setting	0h	Setting value	Frequency [Hz]	Setting value	Frequency [Hz]	_ _ 0 0	Disabled	_ _ 1 0	562	_ _ 0 1	Disabled	_ _ 1 1	529	_ _ 0 2	4500	_ _ 1 2	500	_ _ 0 3	3000	_ _ 1 3	473	_ _ 0 4	2250	_ _ 1 4	450	_ _ 0 5	1800	_ _ 1 5	428	_ _ 0 6	1500	_ _ 1 6	409	_ _ 0 7	1285	_ _ 1 7	391	_ _ 0 8	1125	_ _ 1 8	375	_ _ 0 9	1000	_ _ 1 9	360	_ _ 0 A	900	_ _ 1 A	346	_ _ 0 B	818	_ _ 1 B	333	_ _ 0 C	750	_ _ 1 C	321	_ _ 0 D	692	_ _ 1 D	310	_ _ 0 E	642	_ _ 1 E	300	_ _ 0 F	600	_ _ 1 F	290	Refer to the "Name and function" column.	
Setting digit	Explanation	Initial value																																																																																		
_ _ x x	Shaft resonance suppression filter setting frequency selection Set the shaft resonance suppression filter. Refer to table 5.4 for settings. Set the value closest to the frequency you need.	00h																																																																																		
_ x _ _	Notch depth selection 0: -40 dB 1: -14 dB 2: -8 dB 3: -4 dB	0h																																																																																		
x _ _ _	For manufacturer setting	0h																																																																																		
Setting value	Frequency [Hz]	Setting value	Frequency [Hz]																																																																																	
_ _ 0 0	Disabled	_ _ 1 0	562																																																																																	
_ _ 0 1	Disabled	_ _ 1 1	529																																																																																	
_ _ 0 2	4500	_ _ 1 2	500																																																																																	
_ _ 0 3	3000	_ _ 1 3	473																																																																																	
_ _ 0 4	2250	_ _ 1 4	450																																																																																	
_ _ 0 5	1800	_ _ 1 5	428																																																																																	
_ _ 0 6	1500	_ _ 1 6	409																																																																																	
_ _ 0 7	1285	_ _ 1 7	391																																																																																	
_ _ 0 8	1125	_ _ 1 8	375																																																																																	
_ _ 0 9	1000	_ _ 1 9	360																																																																																	
_ _ 0 A	900	_ _ 1 A	346																																																																																	
_ _ 0 B	818	_ _ 1 B	333																																																																																	
_ _ 0 C	750	_ _ 1 C	321																																																																																	
_ _ 0 D	692	_ _ 1 D	310																																																																																	
_ _ 0 E	642	_ _ 1 E	300																																																																																	
_ _ 0 F	600	_ _ 1 F	290																																																																																	
PB18	LPF	<p>Low-pass filter setting Set the low-pass filter. The following shows a relation of a required parameter to this parameter.</p> <table border="1"> <thead> <tr> <th>[Pr. PB23]</th> <th>[Pr. PB18]</th> </tr> </thead> <tbody> <tr> <td>_ _ 0 _ (Initial value)</td> <td>Automatic setting</td> </tr> <tr> <td>_ _ 1 _</td> <td>Setting value enabled</td> </tr> <tr> <td>_ _ 2 _</td> <td>Setting value disabled</td> </tr> </tbody> </table>	[Pr. PB23]	[Pr. PB18]	_ _ 0 _ (Initial value)	Automatic setting	_ _ 1 _	Setting value enabled	_ _ 2 _	Setting value disabled	3141 [rad/s]	100 to 18000																																																																								
[Pr. PB23]	[Pr. PB18]																																																																																			
_ _ 0 _ (Initial value)	Automatic setting																																																																																			
_ _ 1 _	Setting value enabled																																																																																			
_ _ 2 _	Setting value disabled																																																																																			

5. PARAMETERS

No.	Symbol	Name and function	Initial value [Unit]	Setting range															
PB19	VRF11	Vibration suppression control 1 - Vibration frequency Set the vibration frequency for the vibration suppression control 1 to suppress low-frequency machine vibration. When "Vibration suppression control 2 tuning mode selection" is set to "Automatic setting (_ _ 1 _)" in [Pr. PB02], this parameter will be set automatically. When "Manual setting (_ _ 2 _)" is selected, the setting written to the parameter is used. The setting range of this parameter varies, depending on the value in [Pr. PB07]. If a value out of the range is set, the vibration suppression control will be disabled. Refer to section 7.1.5 for details.	100.0 [Hz]	0.1 to 300.0															
PB20	VRF12	Vibration suppression control 1 - Resonance frequency Set the resonance frequency for the vibration suppression control 1 to suppress low-frequency machine vibration. When "Vibration suppression control 2 tuning mode selection" is set to "Automatic setting (_ _ 1 _)" in [Pr. PB02], this parameter will be set automatically. When "Manual setting (_ _ 2 _)" is selected, the setting written to the parameter is used. The setting range of this parameter varies, depending on the value in [Pr. PB07]. If a value out of the range is set, the vibration suppression control will be disabled. Refer to section 7.1.5 for details.	100.0 [Hz]	0.1 to 300.0															
PB21	VRF13	Vibration suppression control 1 - Vibration frequency damping Set a damping of the vibration frequency for the vibration suppression control 1 to suppress low-frequency machine vibration. When "Vibration suppression control 2 tuning mode selection" is set to "Automatic setting (_ _ 1 _)" in [Pr. PB02], this parameter will be set automatically. When "Manual setting (_ _ 2 _)" is selected, the setting written to the parameter is used. Refer to section 7.1.5 for details.	0.00	0.00 to 0.30															
PB22	VRF14	Vibration suppression control 1 - Resonance frequency damping Set a damping of the resonance frequency for the vibration suppression control 1 to suppress low-frequency machine vibration. When "Vibration suppression control 2 tuning mode selection" is set to "Automatic setting (_ _ 1 _)" in [Pr. PB02], this parameter will be set automatically. When "Manual setting (_ _ 2 _)" is selected, the setting written to the parameter is used. Refer to section 7.1.5 for details.	0.00	0.00 to 0.30															
PB23	VFBF	Low-pass filter selection Select the shaft resonance suppression filter and low-pass filter. <table border="1" data-bbox="347 1196 1230 1644"> <thead> <tr> <th>Setting digit</th> <th>Explanation</th> <th>Initial value</th> </tr> </thead> <tbody> <tr> <td>_ _ _ x</td> <td>Shaft resonance suppression filter selection 0: Automatic setting 1: Manual setting 2: Disabled When you select "Enabled (_ _ _ 1)" of "Machine resonance suppression filter 4 selection" in [Pr. PB49], the shaft resonance suppression filter cannot be used.</td> <td>0h</td> </tr> <tr> <td>_ _ x _</td> <td>Low-pass filter selection 0: Automatic setting 1: Manual setting 2: Disabled</td> <td>0h</td> </tr> <tr> <td>_ x _ _</td> <td>For manufacturer setting</td> <td>0h</td> </tr> <tr> <td>x _ _ _</td> <td></td> <td>0h</td> </tr> </tbody> </table>	Setting digit	Explanation	Initial value	_ _ _ x	Shaft resonance suppression filter selection 0: Automatic setting 1: Manual setting 2: Disabled When you select "Enabled (_ _ _ 1)" of "Machine resonance suppression filter 4 selection" in [Pr. PB49], the shaft resonance suppression filter cannot be used.	0h	_ _ x _	Low-pass filter selection 0: Automatic setting 1: Manual setting 2: Disabled	0h	_ x _ _	For manufacturer setting	0h	x _ _ _		0h	Refer to the "Name and function" column.	
Setting digit	Explanation	Initial value																	
_ _ _ x	Shaft resonance suppression filter selection 0: Automatic setting 1: Manual setting 2: Disabled When you select "Enabled (_ _ _ 1)" of "Machine resonance suppression filter 4 selection" in [Pr. PB49], the shaft resonance suppression filter cannot be used.	0h																	
_ _ x _	Low-pass filter selection 0: Automatic setting 1: Manual setting 2: Disabled	0h																	
_ x _ _	For manufacturer setting	0h																	
x _ _ _		0h																	

5. PARAMETERS

No.	Symbol	Name and function	Initial value [Unit]	Setting range															
PB24	*MVS	Slight vibration suppression control Select the slight vibration suppression control and PI-PID switching control.	Refer to the "Name and function" column.																
		<table border="1"> <thead> <tr> <th>Setting digit</th> <th>Explanation</th> <th>Initial value</th> </tr> </thead> <tbody> <tr> <td>___x</td> <td>Slight vibration suppression control selection 0: Disabled 1: Enabled To enable the slight vibration suppression control, select "Manual mode (___3)" of "Gain adjustment mode selection" in [Pr. PA08]. The slight vibration suppression control selection cannot be used in the speed control mode.</td> <td>0h</td> </tr> <tr> <td>__x_</td> <td>PI-PID switching control selection 0: PI control enabled (Switching to PID control is possible with commands of the servo system controller.) 3: Continuous PID control enabled If the servo motor at a stop is rotated even for a pulse due to any external factor, it generates torque to compensate for a position shift. When the servo motor shaft is to be locked mechanically after positioning completion (stop), enabling the PID control and completing positioning simultaneously will suppress the unnecessary torque generated to compensate for a position shift.</td> <td>0h</td> </tr> <tr> <td>_x__</td> <td>For manufacturer setting</td> <td>0h</td> </tr> <tr> <td>x___</td> <td></td> <td>0h</td> </tr> </tbody> </table>			Setting digit	Explanation	Initial value	___x	Slight vibration suppression control selection 0: Disabled 1: Enabled To enable the slight vibration suppression control, select "Manual mode (___3)" of "Gain adjustment mode selection" in [Pr. PA08]. The slight vibration suppression control selection cannot be used in the speed control mode.	0h	__x_	PI-PID switching control selection 0: PI control enabled (Switching to PID control is possible with commands of the servo system controller.) 3: Continuous PID control enabled If the servo motor at a stop is rotated even for a pulse due to any external factor, it generates torque to compensate for a position shift. When the servo motor shaft is to be locked mechanically after positioning completion (stop), enabling the PID control and completing positioning simultaneously will suppress the unnecessary torque generated to compensate for a position shift.	0h	_x__	For manufacturer setting	0h	x___		0h
		Setting digit			Explanation	Initial value													
		___x			Slight vibration suppression control selection 0: Disabled 1: Enabled To enable the slight vibration suppression control, select "Manual mode (___3)" of "Gain adjustment mode selection" in [Pr. PA08]. The slight vibration suppression control selection cannot be used in the speed control mode.	0h													
__x_	PI-PID switching control selection 0: PI control enabled (Switching to PID control is possible with commands of the servo system controller.) 3: Continuous PID control enabled If the servo motor at a stop is rotated even for a pulse due to any external factor, it generates torque to compensate for a position shift. When the servo motor shaft is to be locked mechanically after positioning completion (stop), enabling the PID control and completing positioning simultaneously will suppress the unnecessary torque generated to compensate for a position shift.	0h																	
_x__	For manufacturer setting	0h																	
x___		0h																	
PB25	*BOP1	Function selection B-1 Select whether to enable or disable the model adaptive control.	Refer to the "Name and function" column.																
		<table border="1"> <thead> <tr> <th>Setting digit</th> <th>Explanation</th> <th>Initial value</th> </tr> </thead> <tbody> <tr> <td>___x</td> <td>Model adaptive control selection 0: Enabled (model adaptive control) 2: Disabled (PID control)</td> <td>0h</td> </tr> <tr> <td>__x_</td> <td>For manufacturer setting</td> <td>0h</td> </tr> <tr> <td>_x__</td> <td></td> <td>0h</td> </tr> <tr> <td>x___</td> <td></td> <td>0h</td> </tr> </tbody> </table>			Setting digit	Explanation	Initial value	___x	Model adaptive control selection 0: Enabled (model adaptive control) 2: Disabled (PID control)	0h	__x_	For manufacturer setting	0h	_x__		0h	x___		0h
		Setting digit			Explanation	Initial value													
		___x			Model adaptive control selection 0: Enabled (model adaptive control) 2: Disabled (PID control)	0h													
		__x_			For manufacturer setting	0h													
_x__		0h																	
x___		0h																	

5. PARAMETERS

No.	Symbol	Name and function	Initial value [Unit]	Setting range															
PB26	*CDP	<p>Gain switching function Select the gain switching condition. Set conditions to enable the gain switching values set in [Pr. PB29] to [Pr. PB36] and [Pr. PB56] to [Pr. PB60].</p> <table border="1"> <thead> <tr> <th>Setting digit</th> <th>Explanation</th> <th>Initial value</th> </tr> </thead> <tbody> <tr> <td>___x</td> <td>Gain switching selection 0: Disabled 1: Control command from controller is enabled 2: Command frequency 3: Droop pulses 4: Servo motor speed</td> <td>0h</td> </tr> <tr> <td>__x_</td> <td>Gain switching condition selection 0: Gain after switching is enabled with gain switching condition or more 1: Gain after switching is enabled with gain switching condition or less</td> <td>0h</td> </tr> <tr> <td>_x__</td> <td>Gain switching time constant disabled condition selection 0: Switching time constant is enabled. 1: Switching time constant is disabled. 2: Return time constant is disabled. Refer to section 7.2.4 for details.</td> <td>0h</td> </tr> <tr> <td>x___</td> <td>For manufacturer setting</td> <td>0h</td> </tr> </tbody> </table>	Setting digit	Explanation	Initial value	___x	Gain switching selection 0: Disabled 1: Control command from controller is enabled 2: Command frequency 3: Droop pulses 4: Servo motor speed	0h	__x_	Gain switching condition selection 0: Gain after switching is enabled with gain switching condition or more 1: Gain after switching is enabled with gain switching condition or less	0h	_x__	Gain switching time constant disabled condition selection 0: Switching time constant is enabled. 1: Switching time constant is disabled. 2: Return time constant is disabled. Refer to section 7.2.4 for details.	0h	x___	For manufacturer setting	0h	Refer to the "Name and function" column.	
Setting digit	Explanation	Initial value																	
___x	Gain switching selection 0: Disabled 1: Control command from controller is enabled 2: Command frequency 3: Droop pulses 4: Servo motor speed	0h																	
__x_	Gain switching condition selection 0: Gain after switching is enabled with gain switching condition or more 1: Gain after switching is enabled with gain switching condition or less	0h																	
_x__	Gain switching time constant disabled condition selection 0: Switching time constant is enabled. 1: Switching time constant is disabled. 2: Return time constant is disabled. Refer to section 7.2.4 for details.	0h																	
x___	For manufacturer setting	0h																	
PB27	CDL	<p>Gain switching condition Set the value of the gain switching (command frequency, droop pulses, or servo motor speed) selected in [Pr. PB26]. The set value unit differs depending on the switching condition item. (Refer to section 7.2.3.)</p>	10 [kpulse/s] /[pulse] /[r/min]	0 to 65535															
PB28	CDT	<p>Gain switching time constant Set the time constant until the gains switch in response to the conditions set in [Pr. PB26] and [Pr. PB27].</p>	1 [ms]	0 to 100															
PB29	GD2B	<p>Load to motor inertia ratio after gain switching Set the load to motor inertia ratio for when gain switching is enabled. This parameter is enabled only when you select "Manual mode (_ _ _ 3)" of "Gain adjustment mode selection" in [Pr. PA08].</p>	7.00 [Multiplier]	0.00 to 300.00															
PB30	PG2B	<p>Position loop gain after gain switching Set the position loop gain for when the gain switching is enabled. When you set a value smaller than 1.0 rad/s, the value will be the same as the value set in [Pr. PB08]. This parameter is enabled only when you select "Manual mode (_ _ _ 3)" of "Gain adjustment mode selection" in [Pr. PA08].</p>	0.0 [rad/s]	0.0 to 2000.0															
PB31	VG2B	<p>Speed loop gain after gain switching Set the speed loop gain for when the gain switching is enabled. When you set a value smaller than 20 rad/s, the value will be the same as the value set in [Pr. PB09]. This parameter is enabled only when you select "Manual mode (_ _ _ 3)" of "Gain adjustment mode selection" in [Pr. PA08].</p>	0 [rad/s]	0 to 65535															

5. PARAMETERS

No.	Symbol	Name and function	Initial value [Unit]	Setting range
PB32	VICB	Speed integral compensation after gain switching Set the speed integral compensation for when the gain switching is enabled. When you set a value smaller than 0.1 ms, the value will be the same as the value set in [Pr. PB10]. This parameter is enabled only when you select "Manual mode (_ _ _ 3)" of "Gain adjustment mode selection" in [Pr. PA08].	0.0 [ms]	0.0 to 5000.0
PB33	VRF11B	Vibration suppression control 1 - Vibration frequency after gain switching Set the vibration frequency of the vibration suppression control 1 for when the gain switching is enabled. When you set a value smaller than 0.1 Hz, the value will be the same as the value set in [Pr. PB19]. This parameter is enabled only when the following conditions are fulfilled. <ul style="list-style-type: none"> • "Gain adjustment mode selection" in [Pr. PA08] is "Manual mode (_ _ _ 3)". • "Vibration suppression control 1 tuning mode selection" in [Pr. PB02] is "Manual setting (_ _ _ 2)". • "Gain switching selection" in [Pr. PB26] is "Control command from controller is enabled (_ _ _ 1)". Switching during driving may cause a shock. Always switch gain after the servo motor stops.	0.0 [Hz]	0.0 to 300.0
PB34	VRF12B	Vibration suppression control 1 - Resonance frequency after gain switching Set the resonance frequency for the vibration suppression control 1 for when the gain switching is enabled. When you set a value smaller than 0.1 Hz, the value will be the same as the value set in [Pr. PB20]. This parameter will be enabled only when the following conditions are fulfilled. <ul style="list-style-type: none"> • "Gain adjustment mode selection" in [Pr. PA08] is "Manual mode (_ _ _ 3)". • "Vibration suppression control 1 tuning mode selection" in [Pr. PB02] is "Manual setting (_ _ _ 2)". • "Gain switching selection" in [Pr. PB26] is "Control command from controller is enabled (_ _ _ 1)". Switching during driving may cause a shock. Always switch gain after the servo motor stops.	0.0 [Hz]	0.0 to 300.0
PB35	VRF13B	Vibration suppression control 1 - Vibration frequency damping after gain switching Set a damping of the vibration frequency for the vibration suppression control 1 for when the gain switching is enabled. This parameter will be enabled only when the following conditions are fulfilled. <ul style="list-style-type: none"> • "Gain adjustment mode selection" in [Pr. PA08] is "Manual mode (_ _ _ 3)". • "Vibration suppression control 1 tuning mode selection" in [Pr. PB02] is "Manual setting (_ _ _ 2)". • "Gain switching selection" in [Pr. PB26] is "Control command from controller is enabled (_ _ _ 1)". Switching during driving may cause a shock. Always switch gain after the servo motor stops.	0.00	0.00 to 0.30
PB36	VRF14B	Vibration suppression control 1 - Resonance frequency damping after gain switching Set a damping of the resonance frequency for the vibration suppression control 1 for when the gain switching is enabled. This parameter will be enabled only when the following conditions are fulfilled. <ul style="list-style-type: none"> • "Gain adjustment mode selection" in [Pr. PA08] is "Manual mode (_ _ _ 3)". • "Vibration suppression control 1 tuning mode selection" in [Pr. PB02] is "Manual setting (_ _ _ 2)". • "Gain switching selection" in [Pr. PB26] is "Control command from controller is enabled (_ _ _ 1)". Switching during driving may cause a shock. Always switch gain after the servo motor stops.	0.00	0.00 to 0.30

5. PARAMETERS

No.	Symbol	Name and function	Initial value [Unit]	Setting range																																																																																																																																																																																																				
PB45	CNHF	Command notch filter Set the command notch filter.	Refer to the "Name and function" column.																																																																																																																																																																																																					
		<table border="1"> <thead> <tr> <th>Setting digit</th> <th>Explanation</th> <th>Initial value</th> </tr> </thead> <tbody> <tr> <td>__ x x</td> <td>Command notch filter setting frequency selection Refer to table 5.5 for the relation of setting values to frequency.</td> <td>00h</td> </tr> <tr> <td>_ x __</td> <td>Notch depth selection Refer to table 5.6 for details.</td> <td>0h</td> </tr> <tr> <td>x ___</td> <td>For manufacturer setting</td> <td>0h</td> </tr> </tbody> </table>			Setting digit	Explanation	Initial value	__ x x	Command notch filter setting frequency selection Refer to table 5.5 for the relation of setting values to frequency.	00h	_ x __	Notch depth selection Refer to table 5.6 for details.	0h	x ___	For manufacturer setting	0h																																																																																																																																																																																								
Setting digit	Explanation	Initial value																																																																																																																																																																																																						
__ x x	Command notch filter setting frequency selection Refer to table 5.5 for the relation of setting values to frequency.	00h																																																																																																																																																																																																						
_ x __	Notch depth selection Refer to table 5.6 for details.	0h																																																																																																																																																																																																						
x ___	For manufacturer setting	0h																																																																																																																																																																																																						
<p align="center">Table 5.5 Command notch filter setting frequency selection</p> <table border="1"> <thead> <tr> <th>Setting value</th> <th>Frequency [Hz]</th> <th>Setting value</th> <th>Frequency [Hz]</th> <th>Setting value</th> <th>Frequency [Hz]</th> </tr> </thead> <tbody> <tr><td>__ 0 0</td><td>Disabled</td><td>__ 2 0</td><td>70</td><td>__ 4 0</td><td>17.6</td></tr> <tr><td>__ 0 1</td><td>2250</td><td>__ 2 1</td><td>66</td><td>__ 4 1</td><td>16.5</td></tr> <tr><td>__ 0 2</td><td>1125</td><td>__ 2 2</td><td>62</td><td>__ 4 2</td><td>15.6</td></tr> <tr><td>__ 0 3</td><td>750</td><td>__ 2 3</td><td>59</td><td>__ 4 3</td><td>14.8</td></tr> <tr><td>__ 0 4</td><td>562</td><td>__ 2 4</td><td>56</td><td>__ 4 4</td><td>14.1</td></tr> <tr><td>__ 0 5</td><td>450</td><td>__ 2 5</td><td>53</td><td>__ 4 5</td><td>13.4</td></tr> <tr><td>__ 0 6</td><td>375</td><td>__ 2 6</td><td>51</td><td>__ 4 6</td><td>12.8</td></tr> <tr><td>__ 0 7</td><td>321</td><td>__ 2 7</td><td>48</td><td>__ 4 7</td><td>12.2</td></tr> <tr><td>__ 0 8</td><td>281</td><td>__ 2 8</td><td>46</td><td>__ 4 8</td><td>11.7</td></tr> <tr><td>__ 0 9</td><td>250</td><td>__ 2 9</td><td>45</td><td>__ 4 9</td><td>11.3</td></tr> <tr><td>__ 0 A</td><td>225</td><td>__ 2 A</td><td>43</td><td>__ 4 A</td><td>10.8</td></tr> <tr><td>__ 0 B</td><td>204</td><td>__ 2 B</td><td>41</td><td>__ 4 B</td><td>10.4</td></tr> <tr><td>__ 0 C</td><td>187</td><td>__ 2 C</td><td>40</td><td>__ 4 C</td><td>10</td></tr> <tr><td>__ 0 D</td><td>173</td><td>__ 2 D</td><td>38</td><td>__ 4 D</td><td>9.7</td></tr> <tr><td>__ 0 E</td><td>160</td><td>__ 2 E</td><td>37</td><td>__ 4 E</td><td>9.4</td></tr> <tr><td>__ 0 F</td><td>150</td><td>__ 2 F</td><td>36</td><td>__ 4 F</td><td>9.1</td></tr> <tr><td>__ 1 0</td><td>140</td><td>__ 3 0</td><td>35.2</td><td>__ 5 0</td><td>8.8</td></tr> <tr><td>__ 1 1</td><td>132</td><td>__ 3 1</td><td>33.1</td><td>__ 5 1</td><td>8.3</td></tr> <tr><td>__ 1 2</td><td>125</td><td>__ 3 2</td><td>31.3</td><td>__ 5 2</td><td>7.8</td></tr> <tr><td>__ 1 3</td><td>118</td><td>__ 3 3</td><td>29.6</td><td>__ 5 3</td><td>7.4</td></tr> <tr><td>__ 1 4</td><td>112</td><td>__ 3 4</td><td>28.1</td><td>__ 5 4</td><td>7.0</td></tr> <tr><td>__ 1 5</td><td>107</td><td>__ 3 5</td><td>26.8</td><td>__ 5 5</td><td>6.7</td></tr> <tr><td>__ 1 6</td><td>102</td><td>__ 3 6</td><td>25.6</td><td>__ 5 6</td><td>6.4</td></tr> <tr><td>__ 1 7</td><td>97</td><td>__ 3 7</td><td>24.5</td><td>__ 5 7</td><td>6.1</td></tr> <tr><td>__ 1 8</td><td>93</td><td>__ 3 8</td><td>23.4</td><td>__ 5 8</td><td>5.9</td></tr> <tr><td>__ 1 9</td><td>90</td><td>__ 3 9</td><td>22.5</td><td>__ 5 9</td><td>5.6</td></tr> <tr><td>__ 1 A</td><td>86</td><td>__ 3 A</td><td>21.6</td><td>__ 5 A</td><td>5.4</td></tr> <tr><td>__ 1 B</td><td>83</td><td>__ 3 B</td><td>20.8</td><td>__ 5 B</td><td>5.2</td></tr> <tr><td>__ 1 C</td><td>80</td><td>__ 3 C</td><td>20.1</td><td>__ 5 C</td><td>5.0</td></tr> <tr><td>__ 1 D</td><td>77</td><td>__ 3 D</td><td>19.4</td><td>__ 5 D</td><td>4.9</td></tr> <tr><td>__ 1 E</td><td>75</td><td>__ 3 E</td><td>18.8</td><td>__ 5 E</td><td>4.7</td></tr> <tr><td>__ 1 F</td><td>72</td><td>__ 3 F</td><td>18.2</td><td>__ 5 F</td><td>4.5</td></tr> </tbody> </table>			Setting value	Frequency [Hz]	Setting value	Frequency [Hz]	Setting value	Frequency [Hz]	__ 0 0	Disabled	__ 2 0	70	__ 4 0	17.6	__ 0 1	2250	__ 2 1	66	__ 4 1	16.5	__ 0 2	1125	__ 2 2	62	__ 4 2	15.6	__ 0 3	750	__ 2 3	59	__ 4 3	14.8	__ 0 4	562	__ 2 4	56	__ 4 4	14.1	__ 0 5	450	__ 2 5	53	__ 4 5	13.4	__ 0 6	375	__ 2 6	51	__ 4 6	12.8	__ 0 7	321	__ 2 7	48	__ 4 7	12.2	__ 0 8	281	__ 2 8	46	__ 4 8	11.7	__ 0 9	250	__ 2 9	45	__ 4 9	11.3	__ 0 A	225	__ 2 A	43	__ 4 A	10.8	__ 0 B	204	__ 2 B	41	__ 4 B	10.4	__ 0 C	187	__ 2 C	40	__ 4 C	10	__ 0 D	173	__ 2 D	38	__ 4 D	9.7	__ 0 E	160	__ 2 E	37	__ 4 E	9.4	__ 0 F	150	__ 2 F	36	__ 4 F	9.1	__ 1 0	140	__ 3 0	35.2	__ 5 0	8.8	__ 1 1	132	__ 3 1	33.1	__ 5 1	8.3	__ 1 2	125	__ 3 2	31.3	__ 5 2	7.8	__ 1 3	118	__ 3 3	29.6	__ 5 3	7.4	__ 1 4	112	__ 3 4	28.1	__ 5 4	7.0	__ 1 5	107	__ 3 5	26.8	__ 5 5	6.7	__ 1 6	102	__ 3 6	25.6	__ 5 6	6.4	__ 1 7	97	__ 3 7	24.5	__ 5 7	6.1	__ 1 8	93	__ 3 8	23.4	__ 5 8	5.9	__ 1 9	90	__ 3 9	22.5	__ 5 9	5.6	__ 1 A	86	__ 3 A	21.6	__ 5 A	5.4	__ 1 B	83	__ 3 B	20.8	__ 5 B	5.2	__ 1 C	80	__ 3 C	20.1	__ 5 C	5.0	__ 1 D	77	__ 3 D	19.4	__ 5 D	4.9	__ 1 E	75	__ 3 E	18.8	__ 5 E	4.7	__ 1 F	72	__ 3 F	18.2	__ 5 F	4.5
Setting value	Frequency [Hz]	Setting value	Frequency [Hz]	Setting value	Frequency [Hz]																																																																																																																																																																																																			
__ 0 0	Disabled	__ 2 0	70	__ 4 0	17.6																																																																																																																																																																																																			
__ 0 1	2250	__ 2 1	66	__ 4 1	16.5																																																																																																																																																																																																			
__ 0 2	1125	__ 2 2	62	__ 4 2	15.6																																																																																																																																																																																																			
__ 0 3	750	__ 2 3	59	__ 4 3	14.8																																																																																																																																																																																																			
__ 0 4	562	__ 2 4	56	__ 4 4	14.1																																																																																																																																																																																																			
__ 0 5	450	__ 2 5	53	__ 4 5	13.4																																																																																																																																																																																																			
__ 0 6	375	__ 2 6	51	__ 4 6	12.8																																																																																																																																																																																																			
__ 0 7	321	__ 2 7	48	__ 4 7	12.2																																																																																																																																																																																																			
__ 0 8	281	__ 2 8	46	__ 4 8	11.7																																																																																																																																																																																																			
__ 0 9	250	__ 2 9	45	__ 4 9	11.3																																																																																																																																																																																																			
__ 0 A	225	__ 2 A	43	__ 4 A	10.8																																																																																																																																																																																																			
__ 0 B	204	__ 2 B	41	__ 4 B	10.4																																																																																																																																																																																																			
__ 0 C	187	__ 2 C	40	__ 4 C	10																																																																																																																																																																																																			
__ 0 D	173	__ 2 D	38	__ 4 D	9.7																																																																																																																																																																																																			
__ 0 E	160	__ 2 E	37	__ 4 E	9.4																																																																																																																																																																																																			
__ 0 F	150	__ 2 F	36	__ 4 F	9.1																																																																																																																																																																																																			
__ 1 0	140	__ 3 0	35.2	__ 5 0	8.8																																																																																																																																																																																																			
__ 1 1	132	__ 3 1	33.1	__ 5 1	8.3																																																																																																																																																																																																			
__ 1 2	125	__ 3 2	31.3	__ 5 2	7.8																																																																																																																																																																																																			
__ 1 3	118	__ 3 3	29.6	__ 5 3	7.4																																																																																																																																																																																																			
__ 1 4	112	__ 3 4	28.1	__ 5 4	7.0																																																																																																																																																																																																			
__ 1 5	107	__ 3 5	26.8	__ 5 5	6.7																																																																																																																																																																																																			
__ 1 6	102	__ 3 6	25.6	__ 5 6	6.4																																																																																																																																																																																																			
__ 1 7	97	__ 3 7	24.5	__ 5 7	6.1																																																																																																																																																																																																			
__ 1 8	93	__ 3 8	23.4	__ 5 8	5.9																																																																																																																																																																																																			
__ 1 9	90	__ 3 9	22.5	__ 5 9	5.6																																																																																																																																																																																																			
__ 1 A	86	__ 3 A	21.6	__ 5 A	5.4																																																																																																																																																																																																			
__ 1 B	83	__ 3 B	20.8	__ 5 B	5.2																																																																																																																																																																																																			
__ 1 C	80	__ 3 C	20.1	__ 5 C	5.0																																																																																																																																																																																																			
__ 1 D	77	__ 3 D	19.4	__ 5 D	4.9																																																																																																																																																																																																			
__ 1 E	75	__ 3 E	18.8	__ 5 E	4.7																																																																																																																																																																																																			
__ 1 F	72	__ 3 F	18.2	__ 5 F	4.5																																																																																																																																																																																																			
<p align="center">Table 5.6 Notch depth selection</p> <table border="1"> <thead> <tr> <th>Setting value</th> <th>Depth [dB]</th> <th>Setting value</th> <th>Depth [dB]</th> </tr> </thead> <tbody> <tr><td>_ 0 __</td><td>-40.0</td><td>_ 8 __</td><td>-6.0</td></tr> <tr><td>_ 1 __</td><td>-24.1</td><td>_ 9 __</td><td>-5.0</td></tr> <tr><td>_ 2 __</td><td>-18.1</td><td>_ A __</td><td>-4.1</td></tr> <tr><td>_ 3 __</td><td>-14.5</td><td>_ B __</td><td>-3.3</td></tr> <tr><td>_ 4 __</td><td>-12.0</td><td>_ C __</td><td>-2.5</td></tr> <tr><td>_ 5 __</td><td>-10.1</td><td>_ D __</td><td>-1.8</td></tr> <tr><td>_ 6 __</td><td>-8.5</td><td>_ E __</td><td>-1.2</td></tr> <tr><td>_ 7 __</td><td>-7.2</td><td>_ F __</td><td>-0.6</td></tr> </tbody> </table>			Setting value	Depth [dB]	Setting value	Depth [dB]	_ 0 __	-40.0	_ 8 __	-6.0	_ 1 __	-24.1	_ 9 __	-5.0	_ 2 __	-18.1	_ A __	-4.1	_ 3 __	-14.5	_ B __	-3.3	_ 4 __	-12.0	_ C __	-2.5	_ 5 __	-10.1	_ D __	-1.8	_ 6 __	-8.5	_ E __	-1.2	_ 7 __	-7.2	_ F __	-0.6																																																																																																																																																																		
Setting value	Depth [dB]	Setting value	Depth [dB]																																																																																																																																																																																																					
_ 0 __	-40.0	_ 8 __	-6.0																																																																																																																																																																																																					
_ 1 __	-24.1	_ 9 __	-5.0																																																																																																																																																																																																					
_ 2 __	-18.1	_ A __	-4.1																																																																																																																																																																																																					
_ 3 __	-14.5	_ B __	-3.3																																																																																																																																																																																																					
_ 4 __	-12.0	_ C __	-2.5																																																																																																																																																																																																					
_ 5 __	-10.1	_ D __	-1.8																																																																																																																																																																																																					
_ 6 __	-8.5	_ E __	-1.2																																																																																																																																																																																																					
_ 7 __	-7.2	_ F __	-0.6																																																																																																																																																																																																					

5. PARAMETERS

No.	Symbol	Name and function	Initial value [unit]	Setting range															
PB46	NH3	Machine resonance suppression filter 3 Set the notch frequency of the machine resonance suppression filter 3. To enable the setting value, select "Enabled (_ _ _ 1)" of "Machine resonance suppression filter 3 selection" in [Pr. PB47].	4500 [Hz]	10 to 4500															
PB47	NHQ3	Notch shape selection 3 Set forms of the machine resonance suppression filter 3. <table border="1" style="width: 100%; border-collapse: collapse;"> <thead> <tr> <th style="width: 15%;">Setting digit</th> <th style="width: 65%;">Explanation</th> <th style="width: 20%;">Initial value</th> </tr> </thead> <tbody> <tr> <td>_ _ _ x</td> <td>Machine resonance suppression filter 3 selection 0: Disabled 1: Enabled</td> <td>0h</td> </tr> <tr> <td>_ _ x _</td> <td>Notch depth selection 0: -40 dB 1: -14 dB 2: -8 dB 3: -4 dB</td> <td>0h</td> </tr> <tr> <td>_ x _ _</td> <td>Notch width selection 0: ± = 2 1: ± = 3 2: ± = 4 3: ± = 5</td> <td>0h</td> </tr> <tr> <td>x _ _ _</td> <td>For manufacturer setting</td> <td>0h</td> </tr> </tbody> </table>	Setting digit	Explanation	Initial value	_ _ _ x	Machine resonance suppression filter 3 selection 0: Disabled 1: Enabled	0h	_ _ x _	Notch depth selection 0: -40 dB 1: -14 dB 2: -8 dB 3: -4 dB	0h	_ x _ _	Notch width selection 0: ± = 2 1: ± = 3 2: ± = 4 3: ± = 5	0h	x _ _ _	For manufacturer setting	0h	Refer to the "Name and function" column.	
Setting digit	Explanation	Initial value																	
_ _ _ x	Machine resonance suppression filter 3 selection 0: Disabled 1: Enabled	0h																	
_ _ x _	Notch depth selection 0: -40 dB 1: -14 dB 2: -8 dB 3: -4 dB	0h																	
_ x _ _	Notch width selection 0: ± = 2 1: ± = 3 2: ± = 4 3: ± = 5	0h																	
x _ _ _	For manufacturer setting	0h																	
PB48	NH4	Machine resonance suppression filter 4 Set the notch frequency of the machine resonance suppression filter 4. To enable the setting value, select "Enabled (_ _ _ 1)" of "Machine resonance suppression filter 4 selection" in [Pr. PB49].	4500 [Hz]	10 to 4500															
PB49	NHQ4	Notch shape selection 4 Set forms of the machine resonance suppression filter 4. <table border="1" style="width: 100%; border-collapse: collapse;"> <thead> <tr> <th style="width: 15%;">Setting digit</th> <th style="width: 65%;">Explanation</th> <th style="width: 20%;">Initial value</th> </tr> </thead> <tbody> <tr> <td>_ _ _ x</td> <td>Machine resonance suppression filter 4 selection 0: Disabled 1: Enabled When you select "Enabled" of this digit, [Pr. PB17 Shaft resonance suppression filter] cannot be used.</td> <td>0h</td> </tr> <tr> <td>_ _ x _</td> <td>Notch depth selection 0: -40 dB 1: -14 dB 2: -8 dB 3: -4 dB</td> <td>0h</td> </tr> <tr> <td>_ x _ _</td> <td>Notch width selection 0: ± = 2 1: ± = 3 2: ± = 4 3: ± = 5</td> <td>0h</td> </tr> <tr> <td>x _ _ _</td> <td>For manufacturer setting</td> <td>0h</td> </tr> </tbody> </table>	Setting digit	Explanation	Initial value	_ _ _ x	Machine resonance suppression filter 4 selection 0: Disabled 1: Enabled When you select "Enabled" of this digit, [Pr. PB17 Shaft resonance suppression filter] cannot be used.	0h	_ _ x _	Notch depth selection 0: -40 dB 1: -14 dB 2: -8 dB 3: -4 dB	0h	_ x _ _	Notch width selection 0: ± = 2 1: ± = 3 2: ± = 4 3: ± = 5	0h	x _ _ _	For manufacturer setting	0h	Refer to the "Name and function" column.	
Setting digit	Explanation	Initial value																	
_ _ _ x	Machine resonance suppression filter 4 selection 0: Disabled 1: Enabled When you select "Enabled" of this digit, [Pr. PB17 Shaft resonance suppression filter] cannot be used.	0h																	
_ _ x _	Notch depth selection 0: -40 dB 1: -14 dB 2: -8 dB 3: -4 dB	0h																	
_ x _ _	Notch width selection 0: ± = 2 1: ± = 3 2: ± = 4 3: ± = 5	0h																	
x _ _ _	For manufacturer setting	0h																	
PB50	NH5	Machine resonance suppression filter 5 Set the notch frequency of the machine resonance suppression filter 5. To enable the setting value, select "Enabled (_ _ _ 1)" of "Machine resonance suppression filter 5 selection" in [Pr. PB51].	4500 [Hz]	10 to 4500															

5. PARAMETERS

No.	Symbol	Name and function	Initial value [unit]	Setting range															
PB51	NHQ5	<p>Notch shape selection 5 Set forms of the machine resonance suppression filter 5. When you select "Enabled (_ _ _ 1)" of "Robust filter selection" in [Pr. PE41], the machine resonance suppression filter 5 cannot be used.</p> <table border="1"> <thead> <tr> <th>Setting digit</th> <th>Explanation</th> <th>Initial value</th> </tr> </thead> <tbody> <tr> <td>_ _ _ x</td> <td>Machine resonance suppression filter 5 selection 0: Disabled 1: Enabled</td> <td>0h</td> </tr> <tr> <td>_ _ x _</td> <td>Notch depth selection 0: -40 dB 1: -14 dB 2: -8 dB 3: -4 dB</td> <td>0h</td> </tr> <tr> <td>_ x _ _</td> <td>Notch width selection 0: ± = 2 1: ± = 3 2: ± = 4 3: ± = 5</td> <td>0h</td> </tr> <tr> <td>x _ _ _</td> <td>For manufacturer setting</td> <td>0h</td> </tr> </tbody> </table>	Setting digit	Explanation	Initial value	_ _ _ x	Machine resonance suppression filter 5 selection 0: Disabled 1: Enabled	0h	_ _ x _	Notch depth selection 0: -40 dB 1: -14 dB 2: -8 dB 3: -4 dB	0h	_ x _ _	Notch width selection 0: ± = 2 1: ± = 3 2: ± = 4 3: ± = 5	0h	x _ _ _	For manufacturer setting	0h	Refer to the "Name and function" column.	
Setting digit	Explanation	Initial value																	
_ _ _ x	Machine resonance suppression filter 5 selection 0: Disabled 1: Enabled	0h																	
_ _ x _	Notch depth selection 0: -40 dB 1: -14 dB 2: -8 dB 3: -4 dB	0h																	
_ x _ _	Notch width selection 0: ± = 2 1: ± = 3 2: ± = 4 3: ± = 5	0h																	
x _ _ _	For manufacturer setting	0h																	
PB52	VRF21	<p>Vibration suppression control 2 - Vibration frequency Set the vibration frequency for the vibration suppression control 2 to suppress low-frequency machine vibration. To enable this setting, select "3 inertia mode (_ _ _ 1)" of "Vibration suppression mode selection" in [Pr. PA24]. When "Vibration suppression control 2 tuning mode selection" is set to "Automatic setting (_ _ 1 _)" in [Pr. PB02], this parameter will be set automatically. When "Manual setting (_ _ 2 _)" is selected, the setting written to the parameter is used. The setting range of this parameter varies, depending on the value in [Pr. PB07]. If a value out of the range is set, the vibration suppression control will be disabled. Refer to section 7.1.5 for details.</p>	100.0 [Hz]	0.1 to 300.0															
PB53	VRF22	<p>Vibration suppression control 2 - Resonance frequency Set the resonance frequency for the vibration suppression control 2 to suppress low-frequency machine vibration. To enable this setting, select "3 inertia mode (_ _ _ 1)" of "Vibration suppression mode selection" in [Pr. PA24]. When "Vibration suppression control 2 tuning mode selection" is set to "Automatic setting (_ _ 1 _)" in [Pr. PB02], this parameter will be set automatically. When "Manual setting (_ _ 2 _)" is selected, the setting written to the parameter is used. The setting range of this parameter varies, depending on the value in [Pr. PB07]. If a value out of the range is set, the vibration suppression control will be disabled. Refer to section 7.1.5 for details.</p>	100.0 [Hz]	0.1 to 300.0															
PB54	VRF23	<p>Vibration suppression control 2 - Vibration frequency damping Set a damping of the vibration frequency for the vibration suppression control 2 to suppress low-frequency machine vibration. To enable this setting, select "3 inertia mode (_ _ _ 1)" of "Vibration suppression mode selection" in [Pr. PA24]. When "Vibration suppression control 2 tuning mode selection" is set to "Automatic setting (_ _ 1 _)" in [Pr. PB02], this parameter will be set automatically. When "Manual setting (_ _ 2 _)" is selected, the setting written to the parameter is used. Refer to section 7.1.5 for details.</p>	0.00	0.00 to 0.30															
PB55	VRF24	<p>Vibration suppression control 2 - Resonance frequency damping Set a damping of the resonance frequency for the vibration suppression control 2 to suppress low-frequency machine vibration. To enable this setting, select "3 inertia mode (_ _ _ 1)" of "Vibration suppression mode selection" in [Pr. PA24]. When "Vibration suppression control 2 tuning mode selection" is set to "Automatic setting (_ _ 1 _)" in [Pr. PB02], this parameter will be set automatically. When "Manual setting (_ _ 2 _)" is selected, the setting written to the parameter is used. Refer to section 7.1.5 for details.</p>	0.00	0.00 to 0.30															

5. PARAMETERS

No.	Symbol	Name and function	Initial value [unit]	Setting range
PB56	VRF21B	<p>Vibration suppression control 2 - Vibration frequency after gain switching</p> <p>Set the vibration frequency for the vibration suppression control 2 for when the gain switching is enabled. When a value less than 0.1 Hz is set, the value will be the same as that of [Pr. PB52].</p> <p>To enable this setting, select "3 inertia mode (_ _ _ 1)" of "Vibration suppression mode selection" in [Pr. PA24].</p> <p>This parameter will be enabled only when the following conditions are fulfilled.</p> <ul style="list-style-type: none"> • "Gain adjustment mode selection" in [Pr. PA08] is "Manual mode (_ _ _ 3)". • "Vibration suppression control 2 tuning mode selection" in [Pr. PB02] is "Manual setting (_ _ 2 _)". • "Gain switching selection" in [Pr. PB26] is "Control command from controller is enabled (_ _ _ 1)". <p>Switching during driving may cause a shock. Always switch gain after the servo motor stops.</p>	0.0 [Hz]	0.0 to 300.0
PB57	VRF22B	<p>Vibration suppression control 2 - Resonance frequency after gain switching</p> <p>Set the resonance frequency for the vibration suppression control 2 for when the gain switching is enabled. When a value less than 0.1 Hz is set, the value will be the same as that of [Pr. PB53].</p> <p>To enable this setting, select "3 inertia mode (_ _ _ 1)" of "Vibration suppression mode selection" in [Pr. PA24].</p> <p>This parameter will be enabled only when the following conditions are fulfilled.</p> <ul style="list-style-type: none"> • "Gain adjustment mode selection" in [Pr. PA08] is "Manual mode (_ _ _ 3)". • "Vibration suppression control 2 tuning mode selection" in [Pr. PB02] is "Manual setting (_ _ 2 _)". • "Gain switching selection" in [Pr. PB26] is "Control command from controller is enabled (_ _ _ 1)". <p>Switching during driving may cause a shock. Always switch gain after the servo motor stops.</p>	0.0 [Hz]	0.0 to 300.0
PB58	VRF23B	<p>Vibration suppression control 2 - Vibration frequency damping after gain switching</p> <p>Set a damping of the vibration frequency for the vibration suppression control 2 for when the gain switching is enabled.</p> <p>To enable this setting, select "3 inertia mode (_ _ _ 1)" of "Vibration suppression mode selection" in [Pr. PA24].</p> <p>This parameter will be enabled only when the following conditions are fulfilled.</p> <ul style="list-style-type: none"> • "Gain adjustment mode selection" in [Pr. PA08] is "Manual mode (_ _ _ 3)". • "Vibration suppression control 2 tuning mode selection" in [Pr. PB02] is "Manual setting (_ _ 2 _)". • "Gain switching selection" in [Pr. PB26] is "Control command from controller is enabled (_ _ _ 1)". <p>Switching during driving may cause a shock. Always switch gain after the servo motor stops.</p>	0.00	0.00 to 0.30
PB59	VRF24B	<p>Vibration suppression control 2 - Resonance frequency damping after gain switching</p> <p>Set a damping of the resonance frequency for the vibration suppression control 2 for when the gain switching is enabled.</p> <p>To enable this setting, select "3 inertia mode (_ _ _ 1)" of "Vibration suppression mode selection" in [Pr. PA24].</p> <p>This parameter will be enabled only when the following conditions are fulfilled.</p> <ul style="list-style-type: none"> • "Gain adjustment mode selection" in [Pr. PA08] is "Manual mode (_ _ _ 3)". • "Vibration suppression control 2 tuning mode selection" in [Pr. PB02] is "Manual setting (_ _ 2 _)". • "Gain switching selection" in [Pr. PB26] is "Control command from controller is enabled (_ _ _ 1)". <p>Switching during driving may cause a shock. Always switch gain after the servo motor stops.</p>	0.00	0.00 to 0.30
PB60	PG1B	<p>Model loop gain after gain switching</p> <p>Set the model loop gain for when the gain switching is enabled.</p> <p>When you set a value smaller than 1.0 rad/s, the value will be the same as the value set in [Pr. PB07].</p> <p>This parameter will be enabled only when the following conditions are fulfilled.</p> <ul style="list-style-type: none"> • "Gain adjustment mode selection" in [Pr. PA08] is "Manual mode (_ _ _ 3)". • "Gain switching selection" in [Pr. PB26] is "Control command from controller is enabled (_ _ _ 1)". <p>Switching during driving may cause a shock. Always switch gain after the servo motor stops.</p>	0.0 [rad/s]	0.0 to 2000.0

5. PARAMETERS

5.2.3 Extension setting parameters ([Pr. PC_ _])

No.	Symbol	Name and function	Initial value [unit]	Setting range															
PC01	ERZ	<p>Error excessive alarm level Set an error excessive alarm level. Set the level in rev unit. Setting "0" will apply 3 rev. Setting over 200 rev will be clamped with 200 rev. Refer to app. 12 for the adjustment method.</p> <p>Note. The setting unit can be changed in [Pr. PC06].</p>	0 [rev] (Note)	0 to 1000															
PC02	MBR	<p>Electromagnetic brake sequence output Set the delay time from when MBR (Electromagnetic brake interlock) turns off until when the base drive circuit is shut-off.</p>	0 [ms]	0 to 1000															
PC04	**COP1	<p>Function selection C-1 Select an encoder cable communication method.</p> <table border="1"> <thead> <tr> <th>Setting digit</th> <th>Explanation</th> <th>Initial value</th> </tr> </thead> <tbody> <tr> <td>___x</td> <td rowspan="3">For manufacturer setting</td> <td>0h</td> </tr> <tr> <td>__x_</td> <td>2h</td> </tr> <tr> <td>_x__</td> <td>0h</td> </tr> <tr> <td>x___</td> <td>Encoder cable communication method selection 0: Two-wire type 1: Four-wire type Incorrect setting will result in [AL. 16 Encoder initial communication error 1]. Or [AL. 20 Encoder normal communication error 1] will occur.</td> <td>0h</td> </tr> </tbody> </table>	Setting digit	Explanation	Initial value	___x	For manufacturer setting	0h	__x_	2h	_x__	0h	x___	Encoder cable communication method selection 0: Two-wire type 1: Four-wire type Incorrect setting will result in [AL. 16 Encoder initial communication error 1]. Or [AL. 20 Encoder normal communication error 1] will occur.	0h	Refer to the "Name and function" column.			
Setting digit	Explanation	Initial value																	
___x	For manufacturer setting	0h																	
__x_		2h																	
_x__		0h																	
x___	Encoder cable communication method selection 0: Two-wire type 1: Four-wire type Incorrect setting will result in [AL. 16 Encoder initial communication error 1]. Or [AL. 20 Encoder normal communication error 1] will occur.	0h																	
PC05	**COP2	<p>Function selection C-2 Set the motor-less operation, test operation, and [AL. 9B Error excessive warning].</p> <table border="1"> <thead> <tr> <th>Setting digit</th> <th>Explanation</th> <th>Initial value</th> </tr> </thead> <tbody> <tr> <td>___x</td> <td>Motor-less operation selection 0: Disabled 1: Enabled</td> <td>0h</td> </tr> <tr> <td>__x_</td> <td>Test operation selection 0: Disabled 1: Enabled</td> <td>0h</td> </tr> <tr> <td>_x__</td> <td>For manufacturer setting</td> <td>0h</td> </tr> <tr> <td>x___</td> <td>[AL. 9B Error excessive warning] selection 0: [AL. 9B Error excessive warning] is disabled. 1: [AL. 9B Error excessive warning] is enabled.</td> <td>0h</td> </tr> </tbody> </table>	Setting digit	Explanation	Initial value	___x	Motor-less operation selection 0: Disabled 1: Enabled	0h	__x_	Test operation selection 0: Disabled 1: Enabled	0h	_x__	For manufacturer setting	0h	x___	[AL. 9B Error excessive warning] selection 0: [AL. 9B Error excessive warning] is disabled. 1: [AL. 9B Error excessive warning] is enabled.	0h	Refer to the "Name and function" column.	
Setting digit	Explanation	Initial value																	
___x	Motor-less operation selection 0: Disabled 1: Enabled	0h																	
__x_	Test operation selection 0: Disabled 1: Enabled	0h																	
_x__	For manufacturer setting	0h																	
x___	[AL. 9B Error excessive warning] selection 0: [AL. 9B Error excessive warning] is disabled. 1: [AL. 9B Error excessive warning] is enabled.	0h																	
PC06	*COP3	<p>Function selection C-3 Select units for the error excessive alarm level setting with [Pr. PC01] and for the error excessive warning level setting with [Pr. PC38]. This parameter cannot be used in the speed control mode and torque control mode.</p> <table border="1"> <thead> <tr> <th>Setting digit</th> <th>Explanation</th> <th>Initial value</th> </tr> </thead> <tbody> <tr> <td>___x</td> <td rowspan="3">For manufacturer setting</td> <td>0h</td> </tr> <tr> <td>__x_</td> <td>0h</td> </tr> <tr> <td>_x__</td> <td>0h</td> </tr> <tr> <td>x___</td> <td>Error excessive alarm/error excessive warning level unit selection 0: 1 rev unit 1: 0.1 rev unit 2: 0.01 rev unit 3: 0.001 rev unit</td> <td>0h</td> </tr> </tbody> </table>	Setting digit	Explanation	Initial value	___x	For manufacturer setting	0h	__x_	0h	_x__	0h	x___	Error excessive alarm/error excessive warning level unit selection 0: 1 rev unit 1: 0.1 rev unit 2: 0.01 rev unit 3: 0.001 rev unit	0h	Refer to the "Name and function" column.			
Setting digit	Explanation	Initial value																	
___x	For manufacturer setting	0h																	
__x_		0h																	
_x__		0h																	
x___	Error excessive alarm/error excessive warning level unit selection 0: 1 rev unit 1: 0.1 rev unit 2: 0.01 rev unit 3: 0.001 rev unit	0h																	

5. PARAMETERS

No.	Symbol	Name and function	Initial value [unit]	Setting range														
PC07	ZSP	Zero speed Set an output range of ZSP (Zero speed detection). ZSP (Zero speed detection) has hysteresis of 20 r/min.	50 [r/min]	0 to 10000														
PC08	OSL	Overspeed alarm detection level Set an overspeed alarm detection level. When you set a value exceeding "servo motor maximum speed × 120%", the set value will be clamped. When you set "0", the value of "servo motor maximum speed × 120%" will be set.	0 [r/min]	0 to 20000														
PC17	**COP4	Function selection C-4 This is used to select a home position setting condition. <table border="1" data-bbox="347 622 1230 853"> <thead> <tr> <th>Setting digit</th> <th>Explanation</th> <th>Initial value</th> </tr> </thead> <tbody> <tr> <td>___x</td> <td>Selection of home position setting condition 0: Need to pass servo motor Z-phase after power on 1: Not need to pass servo motor Z-phase after power on</td> <td>0h</td> </tr> <tr> <td>__x_</td> <td rowspan="3">For manufacturer setting</td> <td>0h</td> </tr> <tr> <td>_x__</td> <td>0h</td> </tr> <tr> <td>x___</td> <td>0h</td> </tr> </tbody> </table>	Setting digit	Explanation	Initial value	___x	Selection of home position setting condition 0: Need to pass servo motor Z-phase after power on 1: Not need to pass servo motor Z-phase after power on	0h	__x_	For manufacturer setting	0h	_x__	0h	x___	0h	Refer to the "Name and function" column.		
Setting digit	Explanation	Initial value																
___x	Selection of home position setting condition 0: Need to pass servo motor Z-phase after power on 1: Not need to pass servo motor Z-phase after power on	0h																
__x_	For manufacturer setting	0h																
_x__		0h																
x___		0h																
PC18	*COP5	Function selection C-5 Select a condition of [AL. E9.1 Servo-on signal on during main circuit off]. <table border="1" data-bbox="347 969 1230 1200"> <thead> <tr> <th>Setting digit</th> <th>Explanation</th> <th>Initial value</th> </tr> </thead> <tbody> <tr> <td>___x</td> <td rowspan="3">For manufacturer setting</td> <td>0h</td> </tr> <tr> <td>__x_</td> <td>0h</td> </tr> <tr> <td>_x__</td> <td>0h</td> </tr> <tr> <td>x___</td> <td>[AL. E9.1 Servo-on signal on during main circuit off] selection 0: Detection with ready-on and servo-on command 1: Detection with servo-on command</td> <td>0h</td> </tr> </tbody> </table>	Setting digit	Explanation	Initial value	___x	For manufacturer setting	0h	__x_	0h	_x__	0h	x___	[AL. E9.1 Servo-on signal on during main circuit off] selection 0: Detection with ready-on and servo-on command 1: Detection with servo-on command	0h	Refer to the "Name and function" column.		
Setting digit	Explanation	Initial value																
___x	For manufacturer setting	0h																
__x_		0h																
_x__		0h																
x___	[AL. E9.1 Servo-on signal on during main circuit off] selection 0: Detection with ready-on and servo-on command 1: Detection with servo-on command	0h																
PC20	*COP7	Function selection C-7 Select a detection method of [AL. 10.2 Bus voltage drop]. <table border="1" data-bbox="347 1317 1230 1621"> <thead> <tr> <th>Setting digit</th> <th>Explanation</th> <th>Initial value</th> </tr> </thead> <tbody> <tr> <td>___x</td> <td rowspan="2">For manufacturer setting</td> <td>0h</td> </tr> <tr> <td>__x_</td> <td>0h</td> </tr> <tr> <td>_x__</td> <td>Undervoltage alarm selection Select the alarm and warning that occurs when the bus voltage drops to the undervoltage alarm level. 0: [AL. 10.2] occurs regardless of the servo motor speed. 1: [AL. E9.1] occurs when the servo motor speed is 50 r/min or less, and [AL. 10.2] occurs when the servo motor speed is over 50 r/min.</td> <td>0h</td> </tr> <tr> <td>x___</td> <td>For manufacturer setting</td> <td>0h</td> </tr> </tbody> </table>	Setting digit	Explanation	Initial value	___x	For manufacturer setting	0h	__x_	0h	_x__	Undervoltage alarm selection Select the alarm and warning that occurs when the bus voltage drops to the undervoltage alarm level. 0: [AL. 10.2] occurs regardless of the servo motor speed. 1: [AL. E9.1] occurs when the servo motor speed is 50 r/min or less, and [AL. 10.2] occurs when the servo motor speed is over 50 r/min.	0h	x___	For manufacturer setting	0h	Refer to the "Name and function" column.	
Setting digit	Explanation	Initial value																
___x	For manufacturer setting	0h																
__x_		0h																
_x__	Undervoltage alarm selection Select the alarm and warning that occurs when the bus voltage drops to the undervoltage alarm level. 0: [AL. 10.2] occurs regardless of the servo motor speed. 1: [AL. E9.1] occurs when the servo motor speed is 50 r/min or less, and [AL. 10.2] occurs when the servo motor speed is over 50 r/min.	0h																
x___	For manufacturer setting	0h																
PC21	*BPS	Alarm history clear Clear the alarm history. <table border="1" data-bbox="347 1738 1230 2042"> <thead> <tr> <th>Setting digit</th> <th>Explanation</th> <th>Initial value</th> </tr> </thead> <tbody> <tr> <td>___x</td> <td>Alarm history clear selection 0: Disabled 1: Enabled When "Enabled" is set, the alarm history will be cleared at the next power-on. Once the alarm history is cleared, the setting becomes disabled automatically.</td> <td>0h</td> </tr> <tr> <td>__x_</td> <td rowspan="3">For manufacturer setting</td> <td>0h</td> </tr> <tr> <td>_x__</td> <td>0h</td> </tr> <tr> <td>x___</td> <td>0h</td> </tr> </tbody> </table>	Setting digit	Explanation	Initial value	___x	Alarm history clear selection 0: Disabled 1: Enabled When "Enabled" is set, the alarm history will be cleared at the next power-on. Once the alarm history is cleared, the setting becomes disabled automatically.	0h	__x_	For manufacturer setting	0h	_x__	0h	x___	0h	Refer to the "Name and function" column.		
Setting digit	Explanation	Initial value																
___x	Alarm history clear selection 0: Disabled 1: Enabled When "Enabled" is set, the alarm history will be cleared at the next power-on. Once the alarm history is cleared, the setting becomes disabled automatically.	0h																
__x_	For manufacturer setting	0h																
_x__		0h																
x___		0h																

5. PARAMETERS

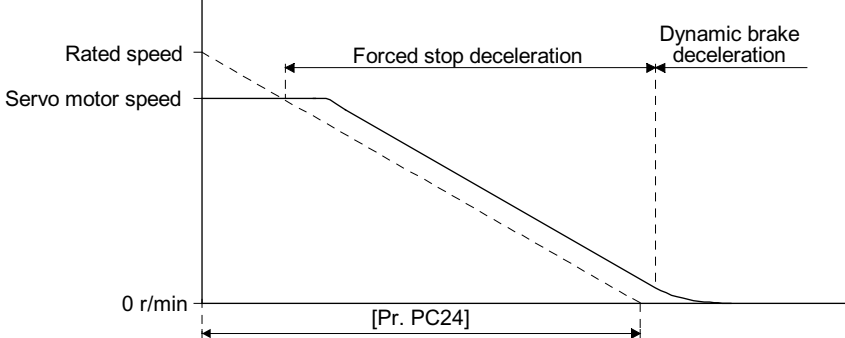
No.	Symbol	Name and function	Initial value [unit]	Setting range													
PC24	RSBR	<p>Forced stop deceleration time constant</p> <p>Set a deceleration time constant for the forced stop deceleration function.</p> <p>Set the time taken from the rated speed to 0 r/min in ms unit.</p> <p>Setting "0" will be 100 ms.</p>  <p>[Precautions]</p> <ul style="list-style-type: none"> • If the servo motor torque is saturated at the maximum torque during forced stop deceleration because the set time is too short, the time to stop will be longer than the set time constant. • [AL. 50 Overload 1] or [AL. 51 Overload 2] may occur during forced stop deceleration, depending on the set value. • After an alarm that leads to a forced stop deceleration has occurred, if an alarm that does not lead to a forced stop deceleration occurs or the power supply is cut, dynamic braking will start regardless of the deceleration time constant setting. • Set a longer time than deceleration time at quick stop of the controller. If a shorter time is set, [AL. 52 Error excessive] may occur. 	100 [ms]	0 to 20000													
PC29	*COPB	<p>Function selection C-B</p> <p>Select the POL reflection at torque control.</p> <table border="1" data-bbox="347 1214 1230 1462"> <thead> <tr> <th>Setting digit</th> <th>Explanation</th> <th>Initial value</th> </tr> </thead> <tbody> <tr> <td>___ x</td> <td rowspan="3">For manufacturer setting</td> <td>0h</td> </tr> <tr> <td>_ _ x _</td> <td>0h</td> </tr> <tr> <td>_ x _ _</td> <td>0h</td> </tr> <tr> <td>x _ _ _</td> <td>POL reflection selection at torque control 0: Enabled 1: Disabled</td> <td>0h</td> </tr> </tbody> </table>	Setting digit	Explanation	Initial value	___ x	For manufacturer setting	0h	_ _ x _	0h	_ x _ _	0h	x _ _ _	POL reflection selection at torque control 0: Enabled 1: Disabled	0h	Refer to the "Name and function" column.	
Setting digit	Explanation	Initial value															
___ x	For manufacturer setting	0h															
_ _ x _		0h															
_ x _ _		0h															
x _ _ _	POL reflection selection at torque control 0: Enabled 1: Disabled	0h															
PC31	RSUP1	<p>Vertical axis freefall prevention compensation amount</p> <p>Set the compensation amount of the vertical axis freefall prevention function.</p> <p>Set the amount in units of the servo motor rotation amount.</p> <p>When a positive value is set, compensation is performed to the address increasing direction.</p> <p>When a negative value is set, compensation is performed to the address decreasing direction.</p> <p>The vertical axis freefall prevention function is performed when all of the following conditions are met.</p> <ol style="list-style-type: none"> 1) Position control mode 2) The value of the parameter is other than "0". 3) The forced stop deceleration function is enabled. 4) An alarm occurs or EM2 turns off when the servo motor speed is zero speed or less. 5) MBR (Electromagnetic brake interlock) was enabled in [Pr. PD07], and the base circuit shut-off delay time was set in [Pr. PC02]. 	0 [0.0001 rev]	-25000 to 25000													

5. PARAMETERS

No.	Symbol	Name and function	Initial value [unit]	Setting range
PC38	ERW	<p>Error excessive warning level</p> <p>Set an error excessive warning level.</p> <p>To enable the parameter, select "Enabled (1 _ _ _)" of "[AL. 9B Error excessive warning] selection" in [Pr. PC05].</p> <p>You can change the setting unit with "Error excessive alarm/error excessive warning level unit selection" in [Pr. PC06].</p> <p>Set the level in rev unit. Setting "0" will apply 1 rev. Setting over 200 rev will be clamped with 200 rev.</p> <p>When an error reaches the set value, [AL. 9B Error excessive warning] will occur. When the error decreases and becomes lower than the set value, the warning will be canceled automatically. The minimum pulse width of the warning signal is 100 [ms].</p> <p>Set values to satisfy the following condition: [Pr. PC38 Error excessive warning level] < [Pr. PC01 Error excessive alarm level] [AL. 52 Error excessive] will occur first when you set as follows: [Pr. PC38 Error excessive warning level] e [Pr. PC01 Error excessive alarm level]</p>	0 [rev]	0 to 1000

5.2.4 I/O setting parameters ([Pr. PD_ _])

No.	Symbol	Name and function	Initial value [unit]	Setting range																																													
PD02	*DIA2	<p>Input signal automatic on selection 2</p> <table border="1" style="width: 100%; border-collapse: collapse;"> <thead> <tr> <th colspan="2">Setting digit</th> <th rowspan="2">Explanation</th> <th rowspan="2">Initial value</th> </tr> <tr> <th>HEX.</th> <th>BIN.</th> </tr> </thead> <tbody> <tr> <td>--- x</td> <td>--- x</td> <td>FLS (Upper stroke limit) selection 0: Disabled 1: Enabled</td> <td rowspan="4">0h</td> </tr> <tr> <td></td> <td>-- x _</td> <td>RLS (Lower stroke limit) selection 0: Disabled 1: Enabled</td> </tr> <tr> <td></td> <td>_ x _ _</td> <td>For manufacturer setting</td> </tr> <tr> <td></td> <td>x _ _ _</td> <td>For manufacturer setting</td> </tr> <tr> <td>-- x _</td> <td rowspan="3" style="text-align: center;">/</td> <td rowspan="3">For manufacturer setting</td> <td>0h</td> </tr> <tr> <td>_ x _ _</td> <td>0h</td> </tr> <tr> <td>x _ _ _</td> <td>0h</td> </tr> </tbody> </table> <p>Convert the setting value into hexadecimal as follows.</p> <div style="display: flex; align-items: center; margin-top: 10px;"> <div style="margin-right: 20px;"> <table border="1" style="border-collapse: collapse; text-align: center;"> <tr><td style="width: 20px; height: 20px;">0</td><td style="width: 20px; height: 20px;">0</td><td style="width: 20px; height: 20px;">0</td><td style="width: 20px; height: 20px;"></td></tr> </table> </div> <div style="margin-right: 20px;"> </div> <table border="1" style="border-collapse: collapse; text-align: center;"> <thead> <tr> <th rowspan="2">Signal name</th> <th colspan="2">Initial value</th> </tr> <tr> <th>BIN</th> <th>HEX</th> </tr> </thead> <tbody> <tr> <td>FLS (Upper stroke limit) selection</td> <td>0</td> <td rowspan="4">0</td> </tr> <tr> <td>RLS (Lower stroke limit) selection</td> <td>0</td> </tr> <tr> <td></td> <td>0</td> </tr> <tr> <td></td> <td>0</td> </tr> </tbody> </table> </div> <p>BIN 0: Use for an external input signal. BIN 1: Automatic on</p>	Setting digit		Explanation	Initial value	HEX.	BIN.	--- x	--- x	FLS (Upper stroke limit) selection 0: Disabled 1: Enabled	0h		-- x _	RLS (Lower stroke limit) selection 0: Disabled 1: Enabled		_ x _ _	For manufacturer setting		x _ _ _	For manufacturer setting	-- x _	/	For manufacturer setting	0h	_ x _ _	0h	x _ _ _	0h	0	0	0		Signal name	Initial value		BIN	HEX	FLS (Upper stroke limit) selection	0	0	RLS (Lower stroke limit) selection	0		0		0	Refer to the "Name and function" column.	
Setting digit		Explanation	Initial value																																														
HEX.	BIN.																																																
--- x	--- x	FLS (Upper stroke limit) selection 0: Disabled 1: Enabled	0h																																														
	-- x _	RLS (Lower stroke limit) selection 0: Disabled 1: Enabled																																															
	_ x _ _	For manufacturer setting																																															
	x _ _ _	For manufacturer setting																																															
-- x _	/	For manufacturer setting	0h																																														
_ x _ _			0h																																														
x _ _ _			0h																																														
0	0	0																																															
Signal name	Initial value																																																
	BIN	HEX																																															
FLS (Upper stroke limit) selection	0	0																																															
RLS (Lower stroke limit) selection	0																																																
	0																																																
	0																																																

5. PARAMETERS

No.	Symbol	Name and function	Initial value [unit]	Setting range																					
PD03	*D11	<p>Input device selection 1 You can assign any input device to the CN3-2 pin.</p> <table border="1"> <thead> <tr> <th>Setting digit</th> <th>Explanation</th> <th>Initial value</th> </tr> </thead> <tbody> <tr> <td>_ _ x x</td> <td>Device selection Refer to table 5.7 for settings. This digit is available with servo amplifier with software version C5 or later. If you set a value other than "00h" for the servo amplifiers manufactured in April 2016 or earlier (or manufactured in China in May 2016 or earlier), [AL. 37] occurs.</td> <td>00h</td> </tr> <tr> <td>_ x _ _</td> <td rowspan="2">For manufacturer setting</td> <td>0h</td> </tr> <tr> <td>x _ _ _</td> <td>0h</td> </tr> </tbody> </table> <p style="text-align: center;">Table 5.7 Selectable input devices</p> <table border="1"> <thead> <tr> <th>Setting value</th> <th>Input device</th> </tr> </thead> <tbody> <tr> <td>_ _ 0 0</td> <td>No assigned function</td> </tr> <tr> <td>_ _ 2 0</td> <td>FLS (Upper stroke limit)</td> </tr> <tr> <td>_ _ 2 1</td> <td>RLS (Lower stroke limit)</td> </tr> <tr> <td>_ _ 2 2</td> <td>DOG (Proximity dog)</td> </tr> </tbody> </table>	Setting digit	Explanation	Initial value	_ _ x x	Device selection Refer to table 5.7 for settings. This digit is available with servo amplifier with software version C5 or later. If you set a value other than "00h" for the servo amplifiers manufactured in April 2016 or earlier (or manufactured in China in May 2016 or earlier), [AL. 37] occurs.	00h	_ x _ _	For manufacturer setting	0h	x _ _ _	0h	Setting value	Input device	_ _ 0 0	No assigned function	_ _ 2 0	FLS (Upper stroke limit)	_ _ 2 1	RLS (Lower stroke limit)	_ _ 2 2	DOG (Proximity dog)	Refer to the "Name and function" column.	
Setting digit	Explanation	Initial value																							
_ _ x x	Device selection Refer to table 5.7 for settings. This digit is available with servo amplifier with software version C5 or later. If you set a value other than "00h" for the servo amplifiers manufactured in April 2016 or earlier (or manufactured in China in May 2016 or earlier), [AL. 37] occurs.	00h																							
_ x _ _	For manufacturer setting	0h																							
x _ _ _		0h																							
Setting value	Input device																								
_ _ 0 0	No assigned function																								
_ _ 2 0	FLS (Upper stroke limit)																								
_ _ 2 1	RLS (Lower stroke limit)																								
_ _ 2 2	DOG (Proximity dog)																								
PD04	*D12	<p>Input device selection 2 You can assign any input device to the CN3-12 pin. The devices that can be assigned and the setting method are the same as in [Pr. PD03].</p> <table border="1"> <thead> <tr> <th>Setting digit</th> <th>Explanation</th> <th>Initial value</th> </tr> </thead> <tbody> <tr> <td>_ _ x x</td> <td>Device selection Refer to table 5.7 in [Pr. PD03] for settings. This digit is available with servo amplifier with software version C5 or later. If you set a value other than "00h" for the servo amplifiers manufactured in April 2016 or earlier (or manufactured in China in May 2016 or earlier), [AL. 37] occurs.</td> <td>00h</td> </tr> <tr> <td>_ x _ _</td> <td rowspan="2">For manufacturer setting</td> <td>0h</td> </tr> <tr> <td>x _ _ _</td> <td>0h</td> </tr> </tbody> </table>	Setting digit	Explanation	Initial value	_ _ x x	Device selection Refer to table 5.7 in [Pr. PD03] for settings. This digit is available with servo amplifier with software version C5 or later. If you set a value other than "00h" for the servo amplifiers manufactured in April 2016 or earlier (or manufactured in China in May 2016 or earlier), [AL. 37] occurs.	00h	_ x _ _	For manufacturer setting	0h	x _ _ _	0h	Refer to the "Name and function" column.											
Setting digit	Explanation	Initial value																							
_ _ x x	Device selection Refer to table 5.7 in [Pr. PD03] for settings. This digit is available with servo amplifier with software version C5 or later. If you set a value other than "00h" for the servo amplifiers manufactured in April 2016 or earlier (or manufactured in China in May 2016 or earlier), [AL. 37] occurs.	00h																							
_ x _ _	For manufacturer setting	0h																							
x _ _ _		0h																							
PD05	*D13	<p>Input device selection 3 You can assign any input device to the CN3-19 pin. The devices that can be assigned and the setting method are the same as in [Pr. PD03].</p> <table border="1"> <thead> <tr> <th>Setting digit</th> <th>Explanation</th> <th>Initial value</th> </tr> </thead> <tbody> <tr> <td>_ _ x x</td> <td>Device selection Refer to table 5.7 in [Pr. PD03] for settings. This digit is available with servo amplifier with software version C5 or later. If you set a value other than "00h" for the servo amplifiers manufactured in April 2016 or earlier (or manufactured in China in May 2016 or earlier), [AL. 37] occurs.</td> <td>00h</td> </tr> <tr> <td>_ x _ _</td> <td rowspan="2">For manufacturer setting</td> <td>0h</td> </tr> <tr> <td>x _ _ _</td> <td>0h</td> </tr> </tbody> </table>	Setting digit	Explanation	Initial value	_ _ x x	Device selection Refer to table 5.7 in [Pr. PD03] for settings. This digit is available with servo amplifier with software version C5 or later. If you set a value other than "00h" for the servo amplifiers manufactured in April 2016 or earlier (or manufactured in China in May 2016 or earlier), [AL. 37] occurs.	00h	_ x _ _	For manufacturer setting	0h	x _ _ _	0h	Refer to the "Name and function" column.											
Setting digit	Explanation	Initial value																							
_ _ x x	Device selection Refer to table 5.7 in [Pr. PD03] for settings. This digit is available with servo amplifier with software version C5 or later. If you set a value other than "00h" for the servo amplifiers manufactured in April 2016 or earlier (or manufactured in China in May 2016 or earlier), [AL. 37] occurs.	00h																							
_ x _ _	For manufacturer setting	0h																							
x _ _ _		0h																							

5. PARAMETERS

No.	Symbol	Name and function	Initial value [unit]	Setting range																																							
PD07	*DO1	<p>Output device selection 1</p> <p>You can assign any output device to the CN3-13 pin. As the initial value, MBR (Electromagnetic brake interlock) is assigned to the pin.</p> <table border="1"> <thead> <tr> <th>Setting digit</th> <th>Explanation</th> <th>Initial value</th> </tr> </thead> <tbody> <tr> <td>__ x x</td> <td>Device selection Refer to table 5.8 for settings.</td> <td>05h</td> </tr> <tr> <td>_ x _ _</td> <td rowspan="2">For manufacturer setting</td> <td>0h</td> </tr> <tr> <td>x _ _ _</td> <td>0h</td> </tr> </tbody> </table> <p>Table 5.8 Selectable output devices</p> <table border="1"> <thead> <tr> <th>Setting value</th> <th>Output device</th> </tr> </thead> <tbody> <tr><td>__ 0 0</td><td>Always off</td></tr> <tr><td>__ 0 2</td><td>RD (Ready)</td></tr> <tr><td>__ 0 3</td><td>ALM (Malfunction)</td></tr> <tr><td>__ 0 4</td><td>INP (In-position)</td></tr> <tr><td>__ 0 5</td><td>MBR (Electromagnetic brake interlock)</td></tr> <tr><td>__ 0 7</td><td>TLC (Limiting torque)</td></tr> <tr><td>__ 0 8</td><td>WNG (Warning)</td></tr> <tr><td>__ 0 9</td><td>BWNG (Battery warning)</td></tr> <tr><td>__ 0 A</td><td>SA (Speed reached)</td></tr> <tr><td>__ 0 C</td><td>ZSP (Zero speed detection)</td></tr> <tr><td>__ 0 F</td><td>CDPS (Variable gain selection)</td></tr> <tr><td>__ 1 1</td><td>ABSV (Absolute position undetermined)</td></tr> <tr><td>__ 1 7</td><td>MTTR (During tough drive)</td></tr> </tbody> </table>	Setting digit	Explanation	Initial value	__ x x	Device selection Refer to table 5.8 for settings.	05h	_ x _ _	For manufacturer setting	0h	x _ _ _	0h	Setting value	Output device	__ 0 0	Always off	__ 0 2	RD (Ready)	__ 0 3	ALM (Malfunction)	__ 0 4	INP (In-position)	__ 0 5	MBR (Electromagnetic brake interlock)	__ 0 7	TLC (Limiting torque)	__ 0 8	WNG (Warning)	__ 0 9	BWNG (Battery warning)	__ 0 A	SA (Speed reached)	__ 0 C	ZSP (Zero speed detection)	__ 0 F	CDPS (Variable gain selection)	__ 1 1	ABSV (Absolute position undetermined)	__ 1 7	MTTR (During tough drive)	Refer to the "Name and function" column.	
Setting digit	Explanation	Initial value																																									
__ x x	Device selection Refer to table 5.8 for settings.	05h																																									
_ x _ _	For manufacturer setting	0h																																									
x _ _ _		0h																																									
Setting value	Output device																																										
__ 0 0	Always off																																										
__ 0 2	RD (Ready)																																										
__ 0 3	ALM (Malfunction)																																										
__ 0 4	INP (In-position)																																										
__ 0 5	MBR (Electromagnetic brake interlock)																																										
__ 0 7	TLC (Limiting torque)																																										
__ 0 8	WNG (Warning)																																										
__ 0 9	BWNG (Battery warning)																																										
__ 0 A	SA (Speed reached)																																										
__ 0 C	ZSP (Zero speed detection)																																										
__ 0 F	CDPS (Variable gain selection)																																										
__ 1 1	ABSV (Absolute position undetermined)																																										
__ 1 7	MTTR (During tough drive)																																										
PD08	*DO2	<p>Output device selection 2</p> <p>You can assign any output device to the CN3-9 pin. As the initial value, Always off is assigned to the pin.</p> <p>The devices that can be assigned and the setting method are the same as in [Pr. PD07].</p> <table border="1"> <thead> <tr> <th>Setting digit</th> <th>Explanation</th> <th>Initial value</th> </tr> </thead> <tbody> <tr> <td>__ x x</td> <td>Device selection Refer to table 5.8 in [Pr. PD07] for settings. This digit is available with servo amplifier with software version C5 or later. If you set a value other than "00h" for the servo amplifiers manufactured in April 2016 or earlier (or manufactured in China in May 2016 or earlier), [AL. 37] occurs.</td> <td>00h</td> </tr> <tr> <td>_ x _ _</td> <td rowspan="2">For manufacturer setting</td> <td>0h</td> </tr> <tr> <td>x _ _ _</td> <td>0h</td> </tr> </tbody> </table>	Setting digit	Explanation	Initial value	__ x x	Device selection Refer to table 5.8 in [Pr. PD07] for settings. This digit is available with servo amplifier with software version C5 or later. If you set a value other than "00h" for the servo amplifiers manufactured in April 2016 or earlier (or manufactured in China in May 2016 or earlier), [AL. 37] occurs.	00h	_ x _ _	For manufacturer setting	0h	x _ _ _	0h	Refer to the "Name and function" column.																													
Setting digit	Explanation	Initial value																																									
__ x x	Device selection Refer to table 5.8 in [Pr. PD07] for settings. This digit is available with servo amplifier with software version C5 or later. If you set a value other than "00h" for the servo amplifiers manufactured in April 2016 or earlier (or manufactured in China in May 2016 or earlier), [AL. 37] occurs.	00h																																									
_ x _ _	For manufacturer setting	0h																																									
x _ _ _		0h																																									

5. PARAMETERS

No.	Symbol	Name and function	Initial value [unit]	Setting range														
PD09	*DO3	<p>Output device selection 3</p> <p>You can assign any output device to the CN3-15 pin. As the initial value, Always off is assigned to the pin.</p> <p>The devices that can be assigned and the setting method are the same as in [Pr. PD07].</p> <table border="1"> <thead> <tr> <th>Setting digit</th> <th>Explanation</th> <th>Initial value</th> </tr> </thead> <tbody> <tr> <td>_ _ x x</td> <td> <p>Device selection</p> <p>Refer to table 5.8 in [Pr. PD07] for settings.</p> <p>This digit is available with servo amplifier with software version C5 or later. If you set a value other than "00h" for the servo amplifiers manufactured in April 2016 or earlier (or manufactured in China in May 2016 or earlier), [AL. 37] occurs.</p> </td> <td>00h</td> </tr> <tr> <td>_ x _ _</td> <td rowspan="2">For manufacturer setting</td> <td>0h</td> </tr> <tr> <td>x _ _ _</td> <td>0h</td> </tr> </tbody> </table>	Setting digit	Explanation	Initial value	_ _ x x	<p>Device selection</p> <p>Refer to table 5.8 in [Pr. PD07] for settings.</p> <p>This digit is available with servo amplifier with software version C5 or later. If you set a value other than "00h" for the servo amplifiers manufactured in April 2016 or earlier (or manufactured in China in May 2016 or earlier), [AL. 37] occurs.</p>	00h	_ x _ _	For manufacturer setting	0h	x _ _ _	0h	Refer to the "Name and function" column.				
Setting digit	Explanation	Initial value																
_ _ x x	<p>Device selection</p> <p>Refer to table 5.8 in [Pr. PD07] for settings.</p> <p>This digit is available with servo amplifier with software version C5 or later. If you set a value other than "00h" for the servo amplifiers manufactured in April 2016 or earlier (or manufactured in China in May 2016 or earlier), [AL. 37] occurs.</p>	00h																
_ x _ _	For manufacturer setting	0h																
x _ _ _		0h																
PD11	*DIF	<p>Input filter setting</p> <p>Select the input filter.</p> <table border="1"> <thead> <tr> <th>Setting digit</th> <th>Explanation</th> <th>Initial value</th> </tr> </thead> <tbody> <tr> <td>_ _ _ x</td> <td> <p>Input signal filter selection</p> <p>Refer to the servo system controller instruction manual for the setting.</p> <p>If an external input signal causes chattering due to noise, etc., use the input filter to suppress it.</p> <p>0: None 1: 0.888 [ms] 2: 1.777 [ms] 3: 2.666 [ms] 4: 3.555 [ms]</p> </td> <td>4h</td> </tr> <tr> <td>_ _ x _</td> <td rowspan="3">For manufacturer setting</td> <td>0h</td> </tr> <tr> <td>_ x _ _</td> <td>0h</td> </tr> <tr> <td>x _ _ _</td> <td>0h</td> </tr> </tbody> </table>	Setting digit	Explanation	Initial value	_ _ _ x	<p>Input signal filter selection</p> <p>Refer to the servo system controller instruction manual for the setting.</p> <p>If an external input signal causes chattering due to noise, etc., use the input filter to suppress it.</p> <p>0: None 1: 0.888 [ms] 2: 1.777 [ms] 3: 2.666 [ms] 4: 3.555 [ms]</p>	4h	_ _ x _	For manufacturer setting	0h	_ x _ _	0h	x _ _ _	0h	Refer to the "Name and function" column.		
Setting digit	Explanation	Initial value																
_ _ _ x	<p>Input signal filter selection</p> <p>Refer to the servo system controller instruction manual for the setting.</p> <p>If an external input signal causes chattering due to noise, etc., use the input filter to suppress it.</p> <p>0: None 1: 0.888 [ms] 2: 1.777 [ms] 3: 2.666 [ms] 4: 3.555 [ms]</p>	4h																
_ _ x _	For manufacturer setting	0h																
_ x _ _		0h																
x _ _ _		0h																
PD13	*DOP2	<p>Function selection D-2</p> <p>Select a condition to turn on INP (In-position).</p> <table border="1"> <thead> <tr> <th>Setting digit</th> <th>Explanation</th> <th>Initial value</th> </tr> </thead> <tbody> <tr> <td>_ _ _ x</td> <td rowspan="2">For manufacturer setting</td> <td>0h</td> </tr> <tr> <td>_ _ x _</td> <td>0h</td> </tr> <tr> <td>_ x _ _</td> <td> <p>INP (In-position) ON condition selection</p> <p>Select a condition to turn on INP (In-position).</p> <p>0: Within the in-position range 1: Within the in-position range and a command has been issued</p> <p>When a command is not input for 1.33 ms, the command is considered to have been issued.</p> </td> <td>0h</td> </tr> <tr> <td>x _ _ _</td> <td>For manufacturer setting</td> <td>0h</td> </tr> </tbody> </table>	Setting digit	Explanation	Initial value	_ _ _ x	For manufacturer setting	0h	_ _ x _	0h	_ x _ _	<p>INP (In-position) ON condition selection</p> <p>Select a condition to turn on INP (In-position).</p> <p>0: Within the in-position range 1: Within the in-position range and a command has been issued</p> <p>When a command is not input for 1.33 ms, the command is considered to have been issued.</p>	0h	x _ _ _	For manufacturer setting	0h	Refer to the "Name and function" column.	
Setting digit	Explanation	Initial value																
_ _ _ x	For manufacturer setting	0h																
_ _ x _		0h																
_ x _ _	<p>INP (In-position) ON condition selection</p> <p>Select a condition to turn on INP (In-position).</p> <p>0: Within the in-position range 1: Within the in-position range and a command has been issued</p> <p>When a command is not input for 1.33 ms, the command is considered to have been issued.</p>	0h																
x _ _ _	For manufacturer setting	0h																

5. PARAMETERS

No.	Symbol	Name and function	Initial value [unit]	Setting range																								
PD14	*DOP3	Function selection D-3																										
		<table border="1"> <thead> <tr> <th>Setting digit</th> <th>Explanation</th> <th>Initial value</th> </tr> </thead> <tbody> <tr> <td>___x</td> <td>For manufacturer setting</td> <td>0h</td> </tr> <tr> <td>__x_</td> <td>Selection of output device at warning occurrence Select the WNG (Warning) and ALM (Malfunction) output status at warning occurrence. Servo amplifier output</td> <td>0h</td> </tr> <tr> <td></td> <td> <table border="1"> <thead> <tr> <th>Setting value</th> <th>(Note 1) Device status</th> </tr> </thead> <tbody> <tr> <td>0</td> <td> <p>Timing diagram for setting 0: WNG and ALM signals at warning occurrence. WNG transitions from 0 to 1 at the warning occurrence. ALM transitions from 1 to 0 at the warning occurrence.</p> </td> </tr> <tr> <td>1</td> <td> <p>Timing diagram for setting 1: WNG and ALM signals at the warning occurrence (Note 2). WNG transitions from 0 to 1. ALM transitions from 1 to 0.</p> </td> </tr> </tbody> </table> <p>Note 1. 0: Off 1: On 2. Although ALM is turned off upon occurrence of the warning, the forced stop deceleration is performed.</p> </td> <td></td> </tr> <tr> <td>_x__</td> <td>For manufacturer setting</td> <td>0h</td> </tr> <tr> <td>x___</td> <td></td> <td>0h</td> </tr> </tbody> </table>	Setting digit	Explanation	Initial value	___x	For manufacturer setting	0h	__x_	Selection of output device at warning occurrence Select the WNG (Warning) and ALM (Malfunction) output status at warning occurrence. Servo amplifier output	0h		<table border="1"> <thead> <tr> <th>Setting value</th> <th>(Note 1) Device status</th> </tr> </thead> <tbody> <tr> <td>0</td> <td> <p>Timing diagram for setting 0: WNG and ALM signals at warning occurrence. WNG transitions from 0 to 1 at the warning occurrence. ALM transitions from 1 to 0 at the warning occurrence.</p> </td> </tr> <tr> <td>1</td> <td> <p>Timing diagram for setting 1: WNG and ALM signals at the warning occurrence (Note 2). WNG transitions from 0 to 1. ALM transitions from 1 to 0.</p> </td> </tr> </tbody> </table> <p>Note 1. 0: Off 1: On 2. Although ALM is turned off upon occurrence of the warning, the forced stop deceleration is performed.</p>	Setting value	(Note 1) Device status	0	<p>Timing diagram for setting 0: WNG and ALM signals at warning occurrence. WNG transitions from 0 to 1 at the warning occurrence. ALM transitions from 1 to 0 at the warning occurrence.</p>	1	<p>Timing diagram for setting 1: WNG and ALM signals at the warning occurrence (Note 2). WNG transitions from 0 to 1. ALM transitions from 1 to 0.</p>		_x__	For manufacturer setting	0h	x___		0h	Refer to the "Name and function" column.	
Setting digit	Explanation	Initial value																										
___x	For manufacturer setting	0h																										
__x_	Selection of output device at warning occurrence Select the WNG (Warning) and ALM (Malfunction) output status at warning occurrence. Servo amplifier output	0h																										
	<table border="1"> <thead> <tr> <th>Setting value</th> <th>(Note 1) Device status</th> </tr> </thead> <tbody> <tr> <td>0</td> <td> <p>Timing diagram for setting 0: WNG and ALM signals at warning occurrence. WNG transitions from 0 to 1 at the warning occurrence. ALM transitions from 1 to 0 at the warning occurrence.</p> </td> </tr> <tr> <td>1</td> <td> <p>Timing diagram for setting 1: WNG and ALM signals at the warning occurrence (Note 2). WNG transitions from 0 to 1. ALM transitions from 1 to 0.</p> </td> </tr> </tbody> </table> <p>Note 1. 0: Off 1: On 2. Although ALM is turned off upon occurrence of the warning, the forced stop deceleration is performed.</p>	Setting value	(Note 1) Device status	0	<p>Timing diagram for setting 0: WNG and ALM signals at warning occurrence. WNG transitions from 0 to 1 at the warning occurrence. ALM transitions from 1 to 0 at the warning occurrence.</p>	1	<p>Timing diagram for setting 1: WNG and ALM signals at the warning occurrence (Note 2). WNG transitions from 0 to 1. ALM transitions from 1 to 0.</p>																					
Setting value	(Note 1) Device status																											
0	<p>Timing diagram for setting 0: WNG and ALM signals at warning occurrence. WNG transitions from 0 to 1 at the warning occurrence. ALM transitions from 1 to 0 at the warning occurrence.</p>																											
1	<p>Timing diagram for setting 1: WNG and ALM signals at the warning occurrence (Note 2). WNG transitions from 0 to 1. ALM transitions from 1 to 0.</p>																											
_x__	For manufacturer setting	0h																										
x___		0h																										

5. PARAMETERS

5.2.5 Extension setting 2 parameters ([Pr. PE_ _])

No.	Symbol	Name and function	Initial value [unit]	Setting range														
PE41	EOP3	Function selection E-3	Refer to the "Name and function" column.															
		<table border="1"> <thead> <tr> <th>Setting digit</th> <th>Explanation</th> <th>Initial value</th> </tr> </thead> <tbody> <tr> <td>___x</td> <td>Robust filter selection 0: Disabled 1: Enabled When you select "Enabled" of this digit, the machine resonance suppression filter 5 set in [Pr. PB51] cannot be used.</td> <td>0h</td> </tr> <tr> <td>__x_</td> <td rowspan="3">For manufacturer setting</td> <td>0h</td> </tr> <tr> <td>_x__</td> <td>0h</td> </tr> <tr> <td>x___</td> <td>0h</td> </tr> </tbody> </table>			Setting digit	Explanation	Initial value	___x	Robust filter selection 0: Disabled 1: Enabled When you select "Enabled" of this digit, the machine resonance suppression filter 5 set in [Pr. PB51] cannot be used.	0h	__x_	For manufacturer setting	0h	_x__	0h	x___	0h	
		Setting digit			Explanation	Initial value												
		___x			Robust filter selection 0: Disabled 1: Enabled When you select "Enabled" of this digit, the machine resonance suppression filter 5 set in [Pr. PB51] cannot be used.	0h												
		__x_			For manufacturer setting	0h												
_x__	0h																	
x___	0h																	
PE44	LMCP	Lost motion compensation positive-side compensation value selection Set the lost motion compensation amount for when the reverse rotation (CW) switches to forward rotation (CCW) in 0.01% unit while considering the rated torque as 100%.	0 [0.01%]	0 to 30000														
PE45	LMCN	Lost motion compensation negative-side compensation value selection Set the lost motion compensation amount for when the forward rotation (CCW) switches to reverse rotation (CW) in 0.01% unit while considering the rated torque as 100%.	0 [0.01%]	0 to 30000														
PE46	LMFLT	Lost motion filter setting Set the time constant of the lost motion compensation filter in units of 0.1 ms. If the time constant is set to "0", the torque is compensated with the value set in [Pr. PE44] and [Pr. PE45]. If the time constant is set to other than "0", the torque is compensated with the high-pass filter output value of the set time constant, and the lost motion compensation will continue.	0 [0.1 ms]	0 to 30000														
PE47	TOF	Torque offset Set this parameter to cancel unbalanced torque of the vertical axis. Set this parameter considering the rated torque of the servo motor as 100%. The torque offset does not need to be set for a machine not generating unbalanced torque. The torque offset set with this parameter will be enabled in the position control mode, speed control mode, and torque control mode. Input commands considering the torque offset in the torque control mode.	0 [0.01%]	-10000 to 10000														
PE48	*LMOP	Lost motion compensation function selection Select the lost motion compensation function.	Refer to the "Name and function" column.															
		<table border="1"> <thead> <tr> <th>Setting value</th> <th>Explanation</th> <th>Initial value</th> </tr> </thead> <tbody> <tr> <td>___x</td> <td>Lost motion compensation selection 0: Lost motion compensation is disabled. 1: Lost motion compensation is enabled.</td> <td>0h</td> </tr> <tr> <td>__x_</td> <td>Lost motion compensation non-sensitive band unit setting 0: 1 pulse unit 1: 1 kpulse unit</td> <td>0h</td> </tr> <tr> <td>_x__</td> <td rowspan="2">For manufacturer setting</td> <td>0h</td> </tr> <tr> <td>x___</td> <td>0h</td> </tr> </tbody> </table>			Setting value	Explanation	Initial value	___x	Lost motion compensation selection 0: Lost motion compensation is disabled. 1: Lost motion compensation is enabled.	0h	__x_	Lost motion compensation non-sensitive band unit setting 0: 1 pulse unit 1: 1 kpulse unit	0h	_x__	For manufacturer setting	0h	x___	0h
		Setting value			Explanation	Initial value												
		___x			Lost motion compensation selection 0: Lost motion compensation is disabled. 1: Lost motion compensation is enabled.	0h												
		__x_			Lost motion compensation non-sensitive band unit setting 0: 1 pulse unit 1: 1 kpulse unit	0h												
_x__	For manufacturer setting	0h																
x___		0h																
PE49	LMCD	Lost motion compensation timing Set the lost motion compensation timing in units of 0.1 ms. Timing to compensate the lost motion can be delayed by the set time.	0 [0.1 ms]	0 to 30000														
PE50	LMCT	Lost motion compensation non-sensitive band Set the lost motion compensation non-sensitive band. When the fluctuation of droop pulses equals to or less than the setting value, the speed will be "0". The setting unit can be changed in [Pr. PE48]. Set this parameter per encoder.	0 [pulse]/ [kpulse]	0 to 65535														

5. PARAMETERS

5.2.6 Extension setting 3 parameters ([Pr. PF_ _])

No.	Symbol	Name and function	Initial value [unit]	Setting range																						
PF06	*FOP5	Function selection F-5 <table border="1" style="width: 100%; border-collapse: collapse;"> <thead> <tr> <th style="width: 15%;">Setting digit</th> <th style="width: 65%;">Explanation</th> <th style="width: 20%;">Initial value</th> </tr> </thead> <tbody> <tr> <td>__ _ x</td> <td>Electronic dynamic brake selection 0: Disabled 3: Automatic (enabled only for specified servo motors) Refer to the following table for the specified servo motors.</td> <td>3h</td> </tr> <tr> <td></td> <td style="text-align: center;"> <table border="1" style="width: 100%; border-collapse: collapse;"> <thead> <tr> <th style="width: 30%;">Series</th> <th>Servo motor</th> </tr> </thead> <tbody> <tr> <td>HG-KN</td> <td>HG-KN053/HG-KN13/HG-KN23/HG-KN43</td> </tr> <tr> <td>HG-SN</td> <td>HG-SN52</td> </tr> </tbody> </table> </td> <td></td> </tr> <tr> <td>_ _ x _</td> <td rowspan="3">For manufacturer setting</td> <td>0h</td> </tr> <tr> <td>_ x _ _</td> <td>0h</td> </tr> <tr> <td>x _ _ _</td> <td>0h</td> </tr> </tbody> </table>	Setting digit	Explanation	Initial value	__ _ x	Electronic dynamic brake selection 0: Disabled 3: Automatic (enabled only for specified servo motors) Refer to the following table for the specified servo motors.	3h		<table border="1" style="width: 100%; border-collapse: collapse;"> <thead> <tr> <th style="width: 30%;">Series</th> <th>Servo motor</th> </tr> </thead> <tbody> <tr> <td>HG-KN</td> <td>HG-KN053/HG-KN13/HG-KN23/HG-KN43</td> </tr> <tr> <td>HG-SN</td> <td>HG-SN52</td> </tr> </tbody> </table>	Series	Servo motor	HG-KN	HG-KN053/HG-KN13/HG-KN23/HG-KN43	HG-SN	HG-SN52		_ _ x _	For manufacturer setting	0h	_ x _ _	0h	x _ _ _	0h	Refer to the "Name and function" column.	
Setting digit	Explanation	Initial value																								
__ _ x	Electronic dynamic brake selection 0: Disabled 3: Automatic (enabled only for specified servo motors) Refer to the following table for the specified servo motors.	3h																								
	<table border="1" style="width: 100%; border-collapse: collapse;"> <thead> <tr> <th style="width: 30%;">Series</th> <th>Servo motor</th> </tr> </thead> <tbody> <tr> <td>HG-KN</td> <td>HG-KN053/HG-KN13/HG-KN23/HG-KN43</td> </tr> <tr> <td>HG-SN</td> <td>HG-SN52</td> </tr> </tbody> </table>	Series	Servo motor	HG-KN	HG-KN053/HG-KN13/HG-KN23/HG-KN43	HG-SN	HG-SN52																			
Series	Servo motor																									
HG-KN	HG-KN053/HG-KN13/HG-KN23/HG-KN43																									
HG-SN	HG-SN52																									
_ _ x _	For manufacturer setting	0h																								
_ x _ _		0h																								
x _ _ _		0h																								
PF12	DBT	Electronic dynamic brake operating time Set an operating time for the electronic dynamic brake.	2000 [ms]	0 to 10000																						
PF21	DRT	Drive recorder switching time setting Set the drive recorder switching time. When USB communication is cut during the use of a graph function, the function will be changed to the drive recorder function after the time set in this parameter has passed. When a value from "1" to "32767" is set, the function will be switched to the drive recorder function after the set time. However, when "0" is set, the function will be switched to the drive recorder function after 600 s. When "-1" is set, the drive recorder function is disabled.	0 [s]	-1 to 32767																						
PF23	OSCL1	Vibration tough drive - Oscillation detection level Set filter readjustment sensitivity levels of [Pr. PB13 Machine resonance suppression filter 1] and [Pr. PB15 Machine resonance suppression filter 2] while the vibration tough drive is enabled. However, setting "0" will be 50%. Example: When you set "50" in the parameter, the filter will be readjusted at the time of 50% or higher oscillation level.	50 [%]	0 to 100																						
PF24	*OSCL2	Vibration tough drive function selection <table border="1" style="width: 100%; border-collapse: collapse;"> <thead> <tr> <th style="width: 15%;">Setting digit</th> <th style="width: 65%;">Explanation</th> <th style="width: 20%;">Initial value</th> </tr> </thead> <tbody> <tr> <td>__ _ x</td> <td>Oscillation detection alarm selection 0: [AL. 54 Oscillation detection] will occur at oscillation detection. 1: [AL. F3.1 Oscillation detection warning] will occur at oscillation detection. 2: Oscillation detection function is disabled. Select whether to generate an alarm or a warning when an oscillation continues at a filter readjustment sensitivity level of [Pr. PF23]. The digit is continuously enabled regardless of the vibration tough drive in [Pr. PA20].</td> <td>0h</td> </tr> <tr> <td>_ _ x _</td> <td rowspan="3">For manufacturer setting</td> <td>0h</td> </tr> <tr> <td>_ x _ _</td> <td>0h</td> </tr> <tr> <td>x _ _ _</td> <td>0h</td> </tr> </tbody> </table>	Setting digit	Explanation	Initial value	__ _ x	Oscillation detection alarm selection 0: [AL. 54 Oscillation detection] will occur at oscillation detection. 1: [AL. F3.1 Oscillation detection warning] will occur at oscillation detection. 2: Oscillation detection function is disabled. Select whether to generate an alarm or a warning when an oscillation continues at a filter readjustment sensitivity level of [Pr. PF23]. The digit is continuously enabled regardless of the vibration tough drive in [Pr. PA20].	0h	_ _ x _	For manufacturer setting	0h	_ x _ _	0h	x _ _ _	0h	Refer to the "Name and function" column.										
Setting digit	Explanation	Initial value																								
__ _ x	Oscillation detection alarm selection 0: [AL. 54 Oscillation detection] will occur at oscillation detection. 1: [AL. F3.1 Oscillation detection warning] will occur at oscillation detection. 2: Oscillation detection function is disabled. Select whether to generate an alarm or a warning when an oscillation continues at a filter readjustment sensitivity level of [Pr. PF23]. The digit is continuously enabled regardless of the vibration tough drive in [Pr. PA20].	0h																								
_ _ x _	For manufacturer setting	0h																								
_ x _ _		0h																								
x _ _ _		0h																								

5. PARAMETERS

No.	Symbol	Name and function	Initial value [unit]	Setting range
PF25	CVAT	<p>Instantaneous power failure tough drive - Detection time</p> <p>Set the time until the occurrence of [AL. 10.1 Voltage drop in the power].</p> <p>To disable the parameter, select "Disabled (_ 0 _ _)" of "instantaneous power failure tough drive selection" in [Pr. PA20].</p> <p>When "Enabled (_ 1 _ _)" of "instantaneous power failure tough drive selection" is selected in [Pr. PA20], the power should be off for the setting value of this parameter +1 s or longer before the power is cycled to enable a parameter whose symbol is preceded by "*" or "**".</p>	200 [ms]	30 to 2000
PF31	FRIC	<p>Machine diagnosis function - Friction judgment speed</p> <p>Set a servo motor speed to divide a friction estimation area into high and low for the friction estimation process of the machine diagnosis.</p> <p>However, when "0" is set, the value will be half of the rated speed.</p> <p>When your operation pattern is under the rated speed, we recommend that you set half value of the maximum speed with this.</p> <p>Set a value larger than [Pr. PC07 Zero speed] for this parameter. If the value is equal to or lower than zero speed, the friction estimation process does not function.</p>	0 [r/min]	0 to permissible speed

6. NORMAL GAIN ADJUSTMENT

6. NORMAL GAIN ADJUSTMENT

POINT
<ul style="list-style-type: none"> ● In the torque control mode, you do not need to make gain adjustment. ● Before making gain adjustment, check that your machine is not being operated at maximum torque of the servo motor. If operated over maximum torque, the machine may vibrate and may operate unexpectedly. In addition, make gain adjustment with a safety margin considering characteristic differences of each machine. It is recommended that generated torque during operation be under 90% of the maximum torque of the servo motor. ● For the vibration suppression control tuning mode, the setting range of [Pr. PB07] is limited. For the vibration suppression control tuning mode, the setting range of [Pr. PB07] is limited. Refer to section 7.1.5 (4) for details.

6.1 Different adjustment methods

6.1.1 Adjustment on a single servo amplifier

The following table shows the gain adjustment modes that can be set on a single servo amplifier. For gain adjustment, first execute "Auto tuning mode 1". If you are not satisfied with the result of the adjustment, execute "Auto tuning mode 2" and "Manual mode" in this order.

(1) Gain adjustment mode explanation

Gain adjustment mode	[Pr. PA08] setting	Estimation of load to motor inertia ratio	Automatically set parameters	Manually set parameters
Auto tuning mode 1 (initial value)	___ 1	Always estimated	GD2 ([Pr. PB06]) PG1 ([Pr. PB07]) PG2 ([Pr. PB08]) VG2 ([Pr. PB09]) VIC ([Pr. PB10])	RSP ([Pr. PA09])
Auto tuning mode 2	___ 2	Fixed to [Pr. PB06] value	PG1 ([Pr. PB07]) PG2 ([Pr. PB08]) VG2 ([Pr. PB09]) VIC ([Pr. PB10])	GD2 ([Pr. PB06]) RSP ([Pr. PA09])
Manual mode	___ 3		/	GD2 ([Pr. PB06]) PG1 ([Pr. PB07]) PG2 ([Pr. PB08]) VG2 ([Pr. PB09]) VIC ([Pr. PB10])
2 gain adjustment mode 1 (interpolation mode)	___ 0	Always estimated	GD2 ([Pr. PB06]) PG2 ([Pr. PB08]) VG2 ([Pr. PB09]) VIC ([Pr. PB10])	PG1 ([Pr. PB07]) RSP ([Pr. PA09])
2 gain adjustment mode 2	___ 4	Fixed to [Pr. PB06] value	PG2 ([Pr. PB08]) VG2 ([Pr. PB09]) VIC ([Pr. PB10])	GD2 ([Pr. PB06]) PG1 ([Pr. PB07]) RSP ([Pr. PA09])

6. NORMAL GAIN ADJUSTMENT

(2) Adjustment sequence and mode usage

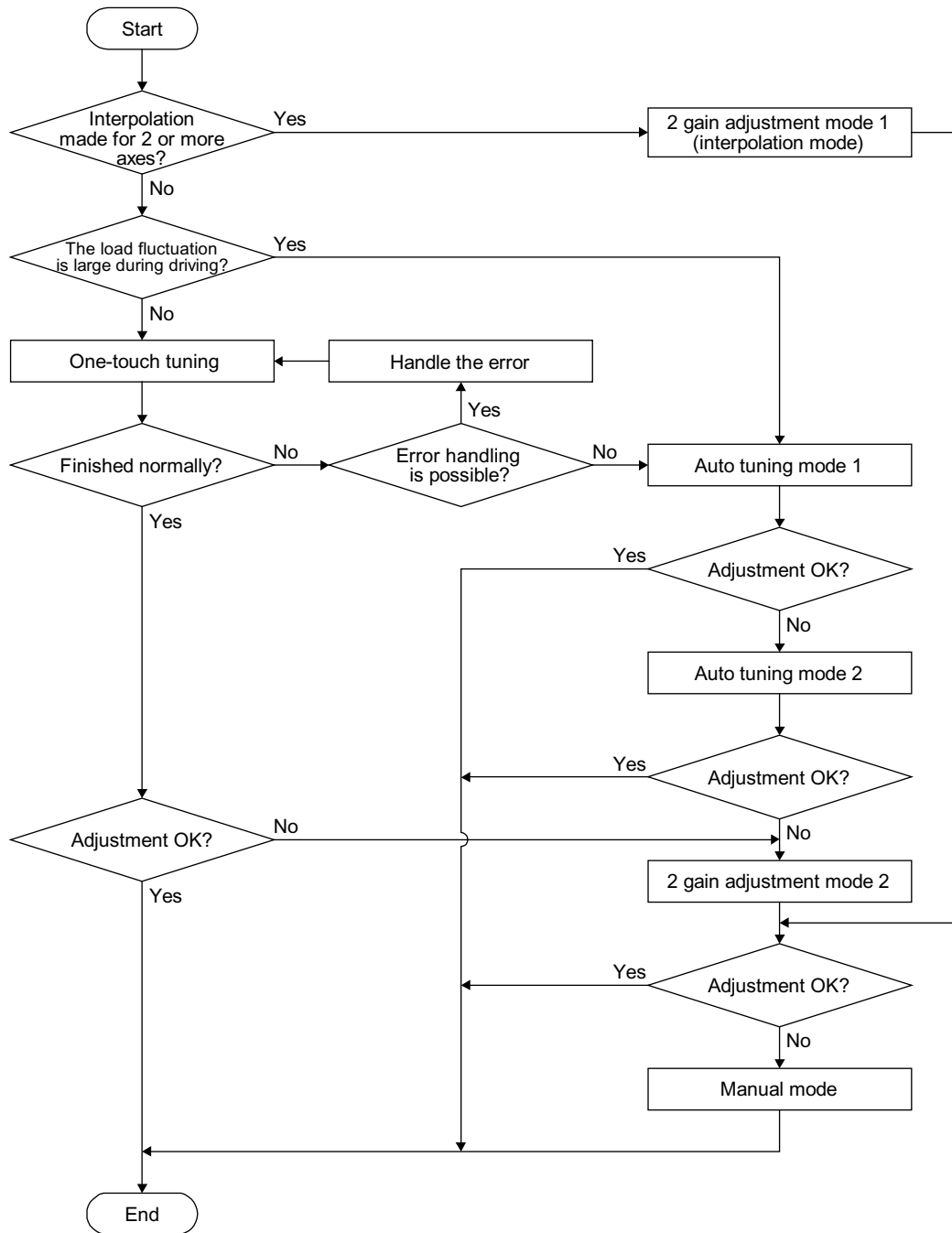

6.1.2 Adjustment using MR Configurator2

This section explains the functions and adjustment using the servo amplifier with MR Configurator2.

Function	Description	Adjustment
Machine analyzer	With the machine and servo motor coupled, the characteristic of the mechanical system can be measured by giving a random vibration command from a personal computer to the servo and measuring the machine response.	You can grasp the machine resonance frequency and determine the notch frequency of the machine resonance suppression filter.

6. NORMAL GAIN ADJUSTMENT

6.2 One-touch tuning

POINT
●When executing the one-touch tuning, check the [Pr. PA21 One-touch tuning function selection] is "_ _ _ 1" (initial value).
●At start of the one-touch tuning, only when "Auto tuning mode 1 (_ _ _ 1)" or "2 gain adjustment mode 1 (interpolation mode) (_ _ _ 0)" of "Gain adjustment mode selection" is selected in [Pr. PA08], [Pr. PB06 Load to motor inertia ratio] will be estimated.
●Execute the one-touch tuning while the servo system controller and the servo amplifier are connected.
●When executing the one-touch tuning in the test operation mode, write the tuning result to servo parameters of the servo system controller, and then connect the servo system controller and the servo amplifier.
●The amplifier command method can be used with the servo amplifier with software version C1 or later and MR Configurator2 with software version 1.45X or later.
●When the one-touch tuning is executed, MR Configurator2 is required.

The one-touch tuning includes two methods: the user command method and the amplifier command method.

(1) User command method

The user command method performs one-touch tuning by inputting commands from outside the servo amplifier.

(2) Amplifier command method

In the amplifier command method, when you simply input a travel distance (permissible travel distance) that collision against the equipment does not occur during servo motor driving, a command for the optimum tuning will be generated inside the servo amplifier to perform one-touch tuning.

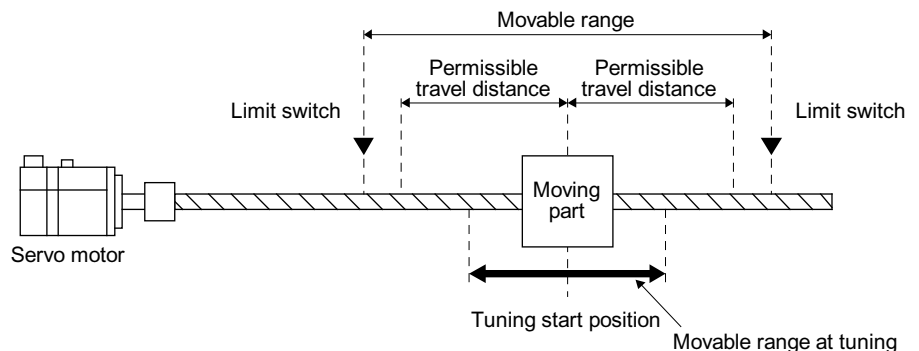

6. NORMAL GAIN ADJUSTMENT

The following parameters are set automatically with one-touch tuning. Also, "Gain adjustment mode selection" in [Pr. PA08] will be "2 gain adjustment mode 2 (_ _ 4)" automatically. Other parameters will be set to an optimum value depending on the setting of [Pr. PA09 Auto tuning response].

Table 6.1 List of parameters automatically set with one-touch tuning

Parameter	Symbol	Name
PA08	ATU	Auto tuning mode
PA09	RSP	Auto tuning response
PB01	FILT	Adaptive tuning mode (adaptive filter II)
PB02	VRFT	Vibration suppression control tuning mode (advanced vibration suppression control II)
PB06	GD2	Load to motor inertia ratio
PB07	PG1	Model loop gain
PB08	PG2	Position loop gain
PB09	VG2	Speed loop gain
PB10	VIC	Speed integral compensation
PB12	OVA	Overshoot amount compensation
PB13	NH1	Machine resonance suppression filter 1
PB14	NHQ1	Notch shape selection 1
PB15	NH2	Machine resonance suppression filter 2
PB16	NHQ2	Notch shape selection 2
PB17	NHF	Shaft resonance suppression filter

Parameter	Symbol	Name
PB18	LPF	Low-pass filter setting
PB19	VRF11	Vibration suppression control 1 - Vibration frequency
PB20	VRF12	Vibration suppression control 1 - Resonance frequency
PB21	VRF13	Vibration suppression control 1 - Vibration frequency damping
PB22	VRF14	Vibration suppression control 1 - Resonance frequency damping
PB23	VFBF	Low-pass filter selection
PB46	NH3	Machine resonance suppression filter 3
PB47	NHQ3	Notch shape selection 3
PB48	NH4	Machine resonance suppression filter 4
PB49	NHQ4	Notch shape selection 4
PB51	NHQ5	Notch shape selection 5
PE41	EOP3	Function selection E-3

6. NORMAL GAIN ADJUSTMENT

6.2.1 One-touch tuning flowchart

(1) User command method

Make one-touch tuning as follows.

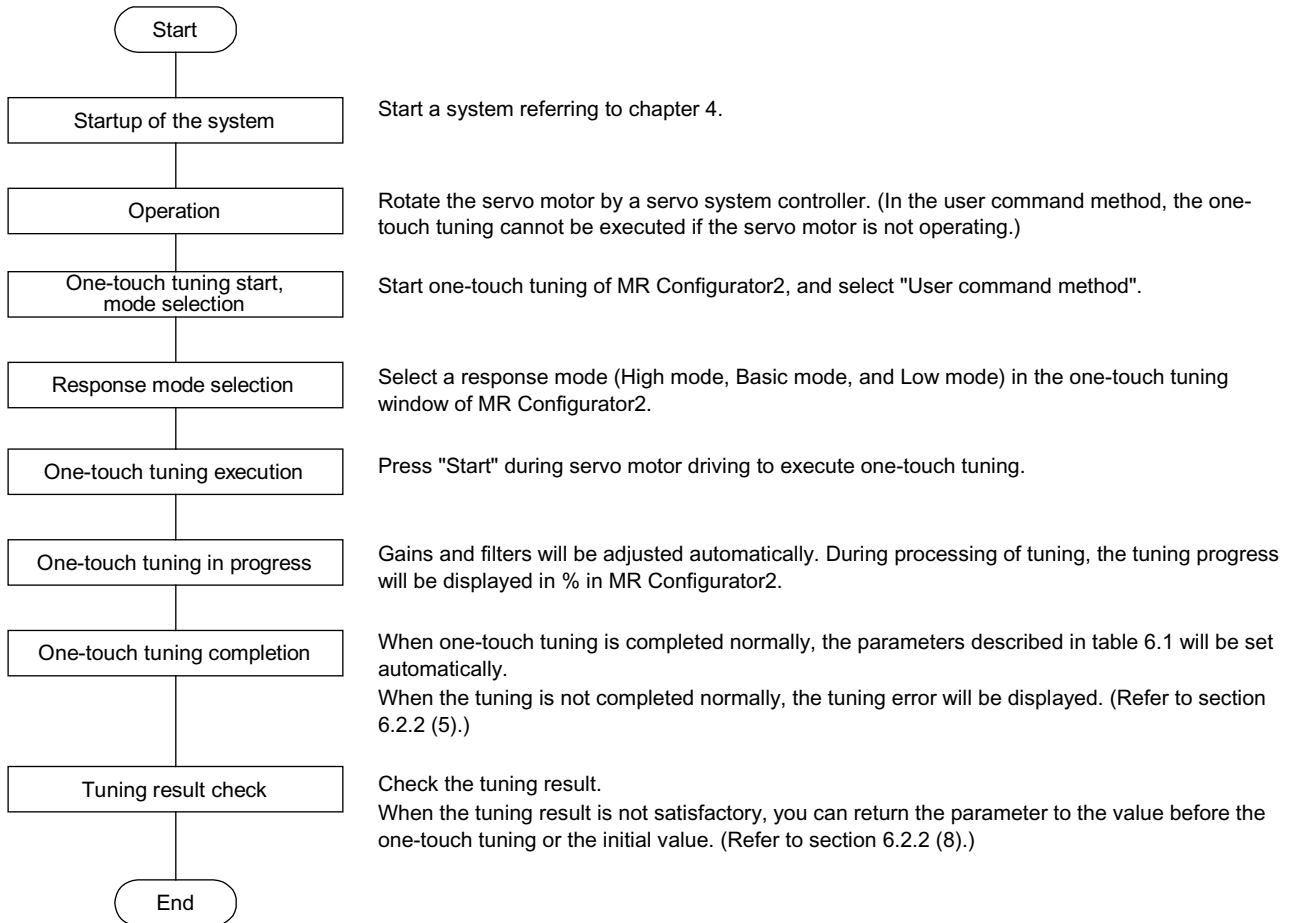

6. NORMAL GAIN ADJUSTMENT

(2) Amplifier command method

Make one-touch tuning as follows.

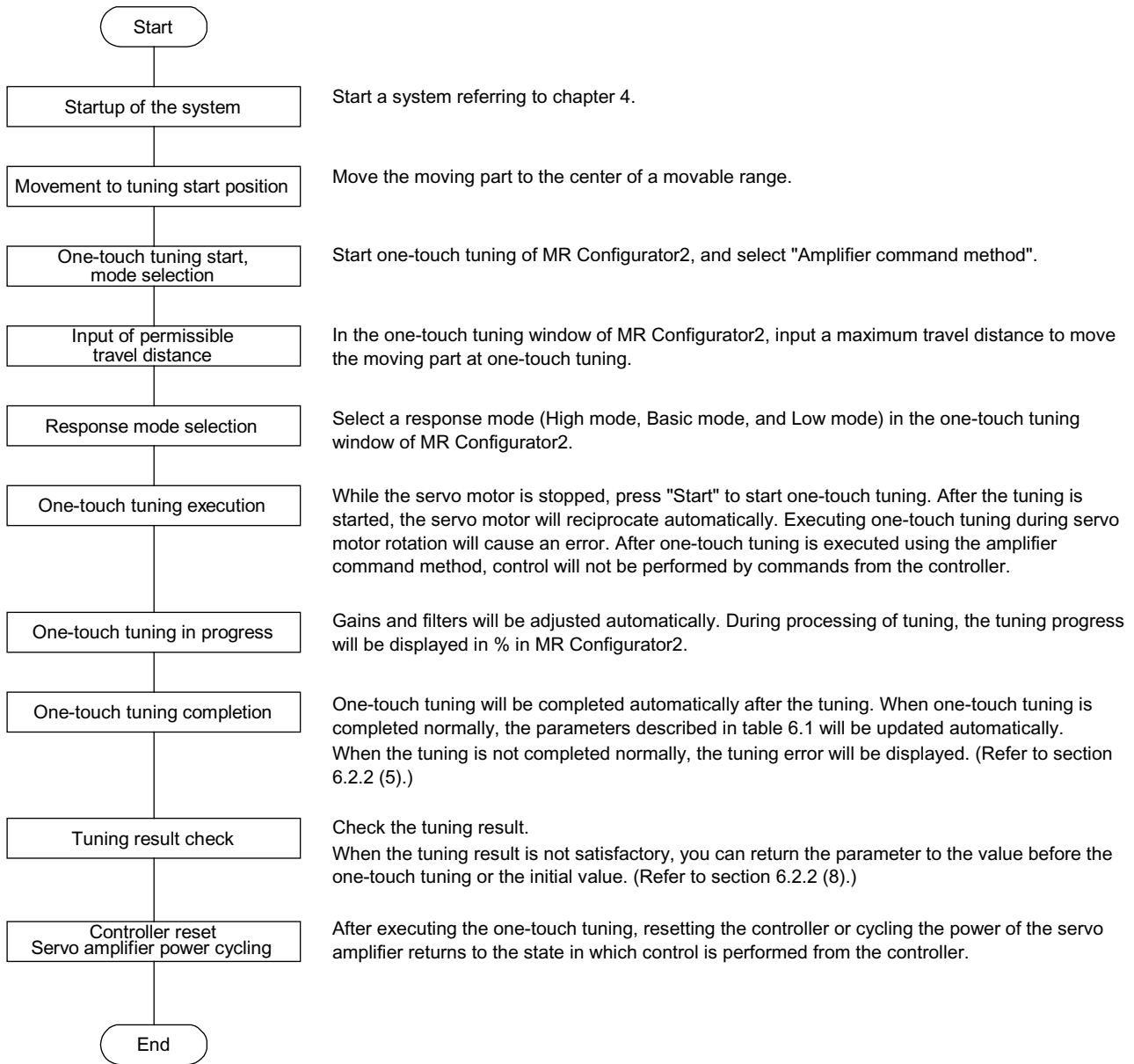

6. NORMAL GAIN ADJUSTMENT

6.2.2 Display transition and operation procedure of one-touch tuning

(1) Command method selection

Select a command method from two methods in the one-touch tuning window of MR Configurator2.

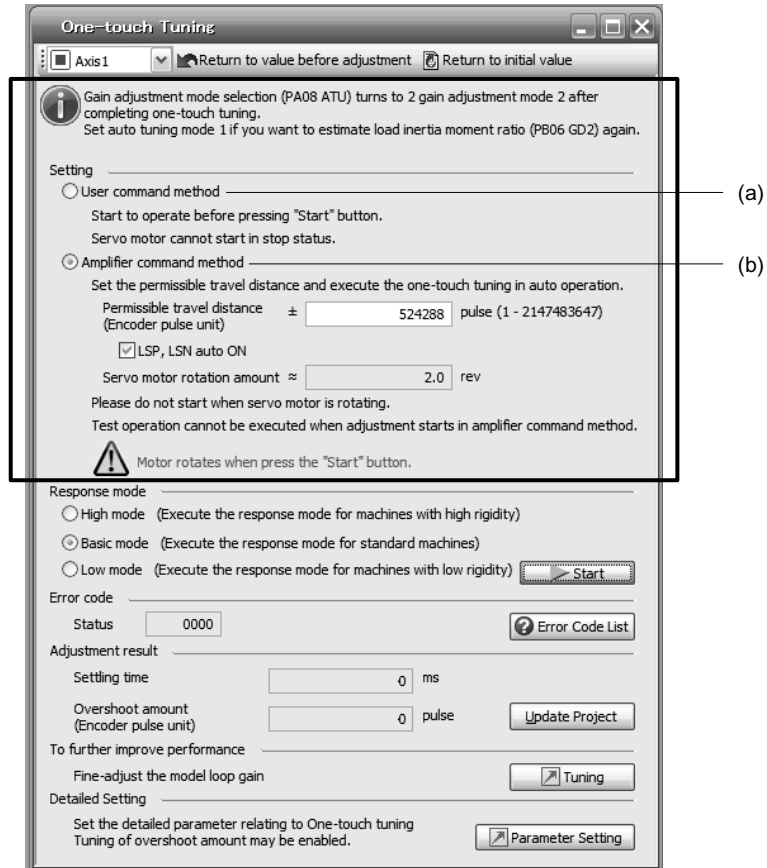

6. NORMAL GAIN ADJUSTMENT

(a) User command method

It is recommended to input commands meeting the following conditions to the servo amplifier. If one-touch tuning is executed while commands which do not meet the conditions are inputted to the servo amplifier, the one-touch tuning error may occur.

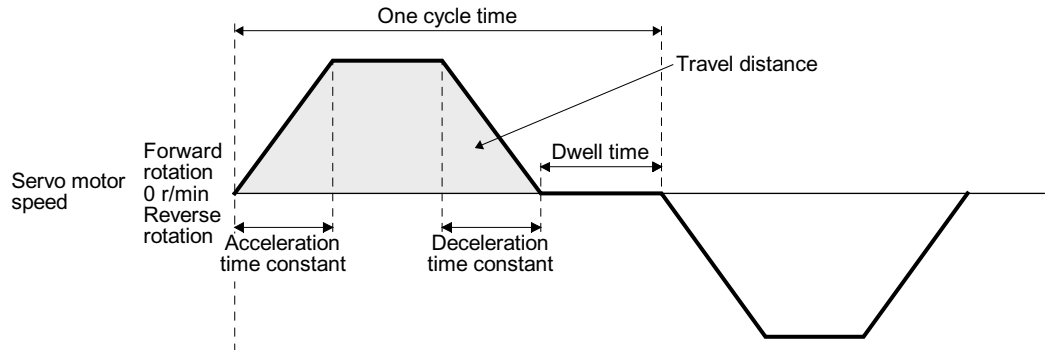

Fig. 6.1 Recommended command for one-touch tuning in the user command method

Item	Description
Travel distance	Set 100 pulses or more in encoder unit. Setting less than 100 pulses will cause the one-touch tuning error "C004".
Servo motor speed	Set 150 r/min or higher. Setting less than 150 r/min may cause the one-touch tuning error "C005".
Acceleration time constant Deceleration time constant	Set the time to reach 2000 r/min to 5 s or less. Set an acceleration time constant/deceleration time constant so that the acceleration/deceleration torque is 10% or more of the rated torque. The estimation accuracy of the load to motor inertia ratio is more improved as the acceleration/deceleration torque is larger, and the one-touch tuning result will be closer to the optimum value.
Dwell time	Set 200 ms or more. Setting a smaller value may cause the one-touch tuning error "C004".
One cycle time	Set 30 s or less. Setting over 30 s will cause the one-touch tuning error "C004".

6. NORMAL GAIN ADJUSTMENT

(b) Amplifier command method

Input a permissible travel distance. Input it in the servo motor-side resolution unit. In the amplifier command method, the servo motor will be operated in a range between "current value \pm permissible travel distance". Input the permissible travel distance as large as possible within a range that the movable part does not collide against the machine. Inputting a small permissible travel distance decreases the possibility that the moving part will collide against the machine. However, the estimation accuracy of the load to motor inertia ratio may be lower, resulting in improper tuning. Also, executing the one-touch tuning in the amplifier command method will generate a command for the following optimum tuning inside the servo amplifier to start the tuning.

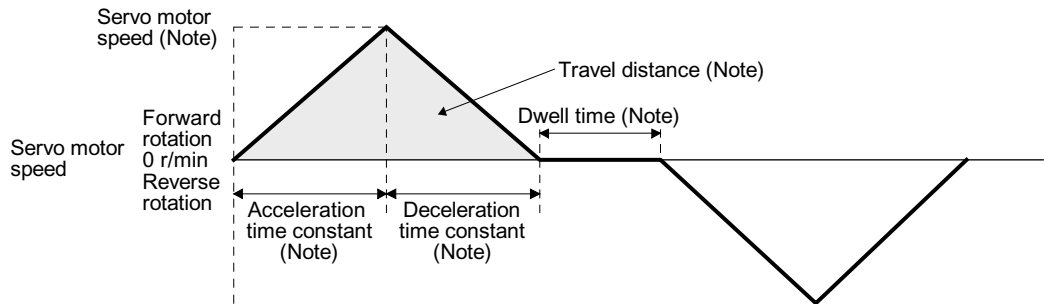

Note. It will be automatically generated in the servo amplifier.

Fig. 6.2 Command generated by one-touch tuning in the amplifier command method

Item	Description
Travel distance	An optimum travel distance will be automatically set in the range not exceeding the user-inputted permissible travel distance with MR Configurator2.
Servo motor speed	A speed not exceeding 1/2 of the rated speed and overspeed alarm detection level ([Pr. PC08]) will be automatically set.
Acceleration time constant Deceleration time constant	An acceleration time constant/deceleration time constant will be automatically set so as not to exceed 60% of the rated torque and the torque limit value set at the start of one-touch tuning in the amplifier command method.
Dwell time	A dwell time in which the one-touch tuning error "C004" does not occur will be automatically set.

6. NORMAL GAIN ADJUSTMENT

(2) Response mode selection

Select a response mode from 3 modes in the one-touch tuning window of MR Configurator2.

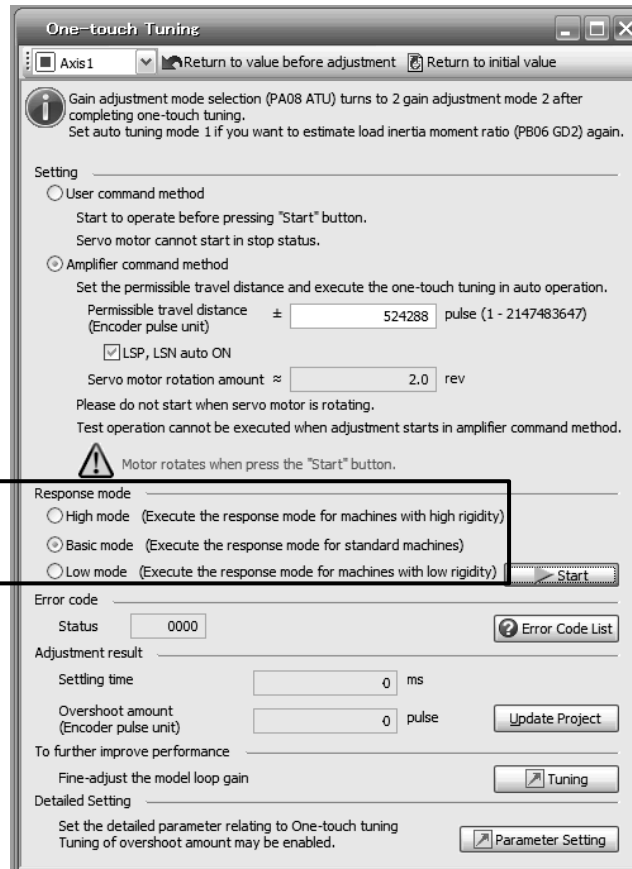

Table 6.2 Response mode explanations

Response mode	Explanation
High mode	This mode is for high-rigid system.
Basic mode	This mode is for standard system.
Low mode	This mode is for low-rigid system.

6. NORMAL GAIN ADJUSTMENT

Refer to the following table for selecting a response mode.

Table 6.3 Guideline for response mode

Response mode			Response	Machine characteristic
Low mode	Basic mode	High mode		Guideline of corresponding machine
↑ ↓	↑ ↓	↑ ↓	Low response ↑ ↓ High response	<p>Arm robot</p> <p>General machine tool conveyor</p> <p>Precision working machine</p> <p>Inserter Mounter Bonder</p>

6. NORMAL GAIN ADJUSTMENT

(3) One-touch tuning execution

POINT
<ul style="list-style-type: none">● For equipment in which overshoot during one-touch tuning is in the permissible level of the in-position range, changing the value of [Pr. PA25 One-touch tuning overshoot permissible level] will shorten the settling time and improve the response.● When executing one-touch tuning in the amplifier command method, turn on EM2. When you turn off EM2 during one-touch tuning, "C008" will be displayed at status in error code, and the one-touch tuning will be canceled.● When executing the one-touch tuning in the amplifier command method, FLS (Upper stroke limit) and RLS (Lower stroke limit) will be disabled. Thus, set a permissible travel distance within a range where moving part collision never occurs, or execute the one-touch tuning in a state in which the servo motor can immediately stop in emergency.

After the response mode is selected in (2) in this section, clicking "Start" will start one-touch tuning. If "Start" is clicked while the servo motor stops, "C002" or "C004" will be displayed at status in error code. (Refer to (5) in this section for error codes.)

Click "Start" with the amplifier command method selected in the servo-off, the servo-on will be automatically enabled, and the one-touch tuning will start. In the one-touch tuning by the amplifier command method, an optimum tuning command will be generated in the servo amplifier after servo-on. Then, the servo motor will reciprocate, and the one-touch tuning will be executed. After the tuning is completed or canceled, the servo amplifier will be the servo-off status. When the servo-on command is inputted from outside, the amplifier will be the servo-on status.

6. NORMAL GAIN ADJUSTMENT

After one-touch tuning is executed using the amplifier command method, control will not be performed by commands from the controller. To return to the state in which control is performed by commands from the controller, reset the controller or cycle the power.

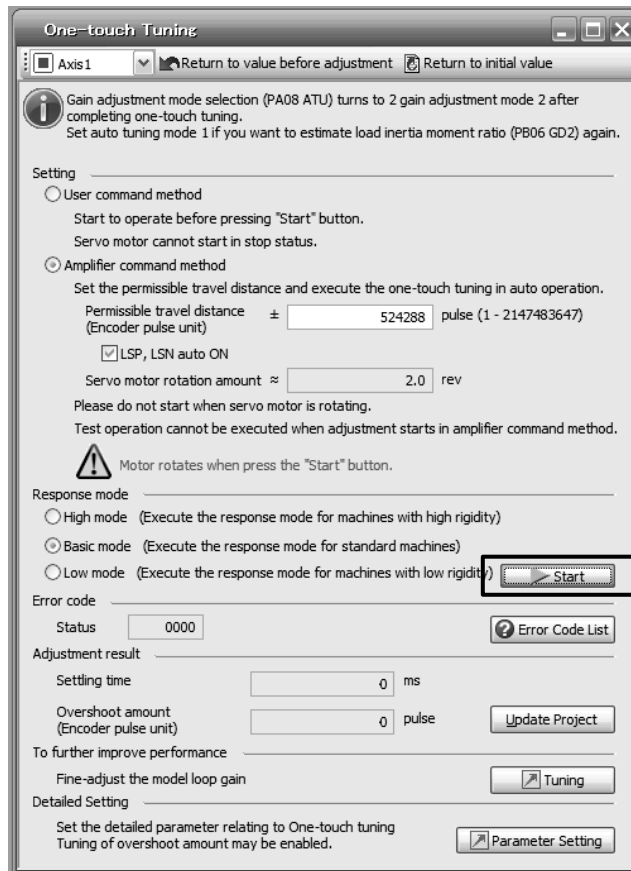

During processing of one-touch tuning, the progress will be displayed as follows. Tuning will be completed at 100%.



Completing the one-touch tuning will start writing tuning parameters to the servo amplifier, and the following window will be displayed. Select whether or not to reflect the tuning result in the project.



6. NORMAL GAIN ADJUSTMENT

After the one-touch tuning is completed, "0000" will be displayed at status in error code. In addition, settling time and overshoot amount will be displayed in "Adjustment result".

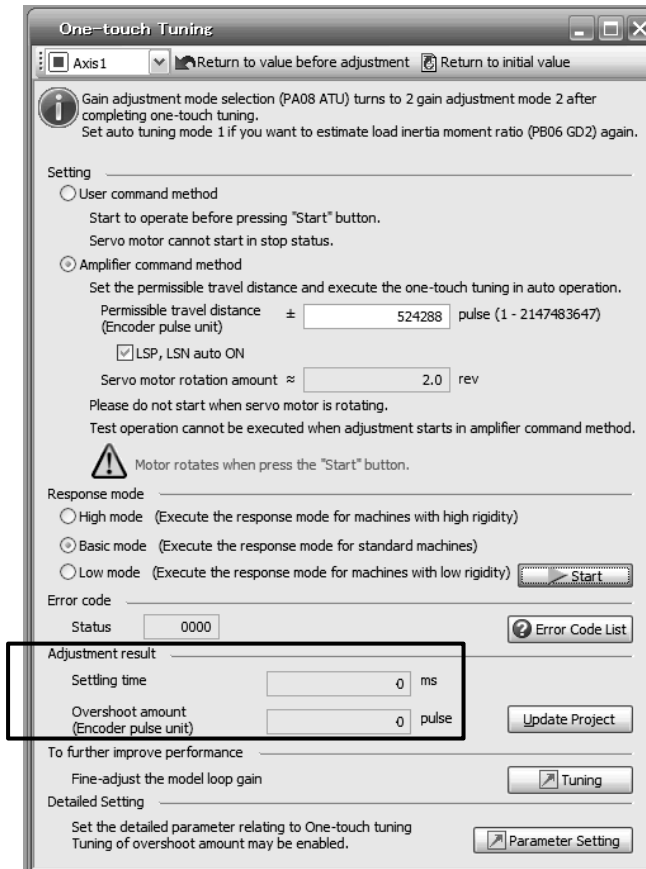

(4) Stop of one-touch tuning

During one-touch tuning, clicking the stop button stops one-touch tuning. At this time, "C000" is displayed at status in error code. After the one-touch tuning is stopped, parameters will return to the values at the start of the one-touch tuning. When executing one-touch tuning again, stop the servo motor once. In addition, after returning the moving part to the tuning start position, execute it.

6. NORMAL GAIN ADJUSTMENT

(5) If an error occurs

If a tuning error occurs during tuning, one-touch tuning will be stopped. With that, the following error code will be displayed in status. Check the cause of tuning error. When executing one-touch tuning again, stop the servo motor once. In addition, after returning the moving part to the tuning start position, execute it.

Display	Name	Error detail	Corrective action example
C000	Tuning canceled	The stop button was clicked during one-touch tuning.	
C001	Overshoot exceeded	Overshoot amount is a value larger than the one set in [Pr. PA10 In-position range] and [Pr. PA25 One-touch tuning - Overshoot permissible level].	Increase the in-position range or overshoot permissible level.
C002	Servo-off during tuning	The one-touch tuning was attempted in the user command method during servo-off. The servo amplifier will be servo-off status during one-touch tuning.	When executing one-touch tuning in the user command method, turn to servo-on, and then execute it. Prevent the servo amplifier from being the servo-off status during one-touch tuning.
C003	Control mode error	1. The one-touch tuning was attempted while the torque control mode was selected in the control modes.	Select the position control mode or speed control mode for the control mode from the controller, and then execute one-touch tuning.
		2. During one-touch tuning, the control mode was attempted to change from the position control mode to the speed control mode.	Do not change the control mode during the one-touch tuning.
C004	Time-out	1. One cycle time during the operation has been over 30 s.	Set one cycle time during the operation (time from the command start to the next command start) to 30 s or less.
		2. The command speed is slow.	Set the servo motor speed to 100 r/min or higher. Error is less likely to occur as the setting speed is higher. When one-touch tuning by the amplifier command is used, set a permissible travel distance so that the servo motor speed is 100 r/min or higher. Set a permissible travel distance to two or more revolutions as a guide value to set the servo motor speed to 100 r/min.
		3. The operation interval of the continuous operation is short.	Set the stop interval during operation to 200 ms or more. Error is less likely to occur as the setting time is longer.
C005	Load to motor inertia ratio misestimated	1. The estimation of the load to motor inertia ratio at one-touch tuning was a failure.	Drive the motor with meeting conditions as follows. <ul style="list-style-type: none"> • The acceleration time constant/deceleration time constant to reach 2000 r/min is 5 s or less. • Speed is 150 r/min or higher. • The load to motor inertia ratio is 100 times or less. • The acceleration/deceleration torque is 10% or more of the rated torque.
		2. The load to motor inertia ratio was not estimated due to an oscillation or other influences.	Set to the auto tuning mode that does not estimate the load to motor inertia ratio as follows, and then execute the one-touch tuning. <ul style="list-style-type: none"> • Select "Auto tuning mode 2 (_ _ _ 2)", "Manual mode (_ _ _ 3)", or "2 gain adjustment mode 2 (_ _ _ 4)" of "Gain adjustment mode selection" in [Pr. PA08]. • Manually set [Pr. PB06 Load to motor inertia ratio] properly.

6. NORMAL GAIN ADJUSTMENT

Display	Name	Error detail	Corrective action example
C006	Amplifier command start error	One-touch tuning was attempted to start in the amplifier command method under the following speed condition. Servo motor speed: 20 r/min or higher	Execute the one-touch tuning in the amplifier command method while the servo motor is stopped.
C007	Amplifier command generation error	1. One-touch tuning was executed in the amplifier command method when the permissible travel distance is set to 100 pulses or less in the encoder pulse unit, or the distance is set not to increase the servo motor speed to 150 r/min or higher at the time of load to motor inertia ratio estimation.	Set a permissible travel distance to 100 pulses or more in the encoder pulse unit, or a distance so as to increase the servo motor speed to 150 r/min or higher at the time of load to motor inertia ratio estimation, and then execute the one-touch tuning. Set a permissible travel distance to four or more revolutions as a guide value. Load to motor inertia ratio will be estimated when "0000" or "0001" is set in [Pr. PA08 Auto tuning mode] at the start of one-touch tuning. If the permissible travel distance is short and the servo motor speed cannot be increased to 150 r/min or higher, select "Auto tuning mode 2 (_ _ _ 2)", "Manual mode (_ _ _ 3)", or "2 gain adjustment mode 2 (_ _ _ 4)" of "Gain adjustment mode selection" in [Pr. PA08].
		2. An overspeed alarm detection level is set so that the servo motor speed becomes 150 r/min or less at the time of load to motor inertia ratio estimation.	When estimating the load to motor inertia ratio, set the overspeed alarm detection level so that the speed becomes 150 r/min or more.
		3. The torque limit has been set to 0.	Set the torque limit value to greater than 0.
C008	Stop signal	EM2 was turned off during one-touch tuning in the amplifier command method.	Review the one-touch tuning start position and permissible travel distance for the amplifier command method. After ensuring safety, turn on EM2.
C009	Parameter	Parameters for manufacturer setting have been changed.	Return the parameters for manufacturer setting to the initial values.
C00A	Alarm	One-touch tuning was attempted to start in the amplifier command method during alarm or warning. Alarm or warning occurred during one-touch tuning by the amplifier command method.	Start one-touch tuning when no alarm or warning occurs. Prevent alarm or warning from occurring during one-touch tuning.
C00F	One-touch tuning disabled	"One-touch tuning function selection" in [Pr. PA21] is "Disabled (_ _ _ 0)".	Select "Enabled (_ _ _ 1)".

(6) If an alarm occurs

If an alarm occurs during the one-touch tuning, the tuning will be forcibly terminated. Remove the cause of the alarm and execute one-touch tuning again. When executing one-touch tuning in the amplifier command method again, return the moving part to the tuning start position.

(7) If a warning occurs

If a warning which continues the motor driving occurs during one-touch tuning by the user command method, the tuning will be continued. If a warning which does not continue the motor driving occurs during the tuning, one-touch tuning will be stopped.

One-touch tuning will be stopped when warning occurs during one-touch tuning by the amplifier command method regardless of the warning type. Remove the cause of the warning, and return the moving part to the tuning start position. Then, execute the tuning again.

6. NORMAL GAIN ADJUSTMENT

(8) Initializing one-touch tuning

Clicking "Return to initial value" in the one-touch tuning window of MR Configurator2 enables to return the parameter to the initial value. Refer to table 6.1 for the parameters which you can initialize.

Clicking "Return to value before adjustment" in the one-touch tuning window of MR Configurator2 enables to return the parameter to the value before clicking "Start".

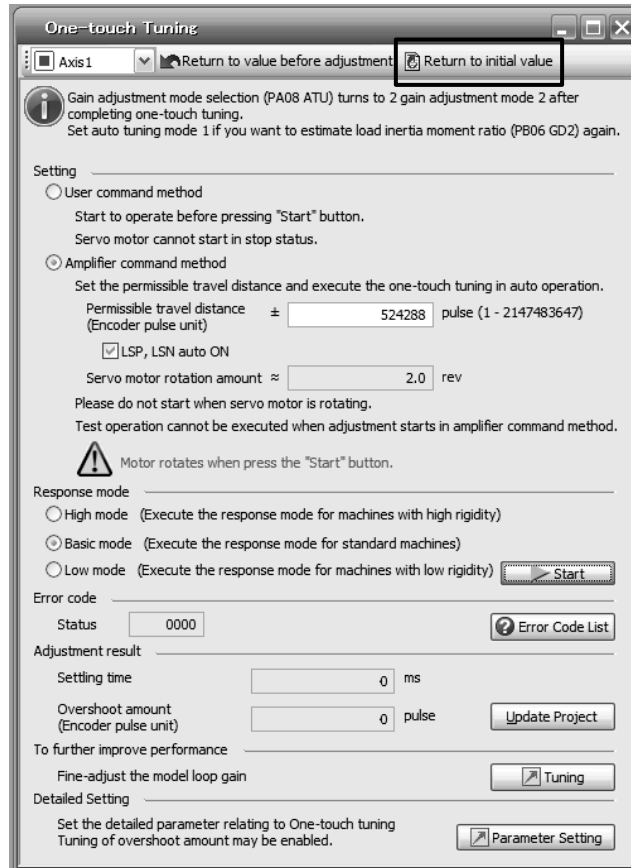

When the initialization of one-touch tuning is completed, the following window will be displayed. (returning to initial value)



6. NORMAL GAIN ADJUSTMENT

6.2.3 Caution for one-touch tuning

- (1) Caution common for user command method and amplifier command method
 - (a) The tuning is not available in the torque control mode.
 - (b) The one-touch tuning cannot be executed while an alarm or warning which does not continue the motor driving is occurring.
 - (c) The one-touch tuning cannot be executed during the following test operation mode.
 - 1) Output signal (DO) forced output
 - 2) Motor-less operation
 - (d) If one-touch tuning is performed when the gain switching function is enabled, vibration and/or unusual noise may occur during the tuning.
- (2) Caution for amplifier command method
 - (a) Starting one-touch tuning while the servo motor is rotating displays "C006" at status in error code, and the one-touch tuning cannot be executed.
 - (b) One-touch tuning is not available during the test operation mode. The following test operation modes cannot be executed during one-touch tuning.
 - 1) Positioning operation
 - 2) JOG operation
 - 3) Program operation
 - 4) Machine analyzer operation
 - (c) After one-touch tuning is executed, control will not be performed by commands from the servo system controller. To return to the state in which control is performed from the servo system controller, reset the controller or cycle the power of the servo amplifier.
 - (d) During one-touch tuning, the permissible travel distance may be exceeded due to overshoot, set a value sufficient to prevent machine collision.
 - (e) When Auto tuning mode 2, Manual mode, or 2 gain adjustment mode 2 is selected in [Pr. PA08 Auto tuning mode], the load to motor inertia ratio will not be estimated. An optimum acceleration/deceleration command will be generated by [Pr. PB06 Load to motor inertia ratio] at the start of one-touch tuning. When the load to motor inertia ratio is incorrect, the optimum acceleration/deceleration command may not be generated, causing the tuning to fail.
 - (f) When one-touch tuning is started by using USB communication, if the USB communication is interrupted during the tuning, the servo motor will stop, and the tuning will also stop. The parameter will return to the one at the start of the one-touch tuning.
 - (g) When one-touch tuning is started via the controller, if communication between the controller and the servo amplifier or personal computer is shut-off during the tuning, the servo motor will stop, and the tuning will also stop. The parameter will return to the one at the start of the one-touch tuning.
 - (h) When one-touch tuning is started during the speed control mode, the mode will be switched to the position control mode automatically. The tuning result may differ from the one obtained by executing tuning by using the speed command.

6. NORMAL GAIN ADJUSTMENT

6.3 Auto tuning

6.3.1 Auto tuning mode

The servo amplifier has a real-time auto tuning function which estimates the machine characteristic (load to motor inertia ratio) in real time and automatically sets the optimum gains according to that value. This function permits ease of gain adjustment of the servo amplifier.

(1) Auto tuning mode 1

The servo amplifier is factory-set to the auto tuning mode 1.

In this mode, the load to motor inertia ratio of a machine is always estimated to set the optimum gains automatically.

The following parameters are automatically adjusted in the auto tuning mode 1.

Parameter	Symbol	Name
PB06	GD2	Load to motor inertia ratio
PB07	PG1	Model loop gain
PB08	PG2	Position loop gain
PB09	VG2	Speed loop gain
PB10	VIC	Speed integral compensation

POINT
<ul style="list-style-type: none"> ● The auto tuning mode 1 may not be performed properly if all of the following conditions are not satisfied. <ul style="list-style-type: none"> ▪ The acceleration/deceleration time constant to reach 2000 r/min is 5 s or shorter. ▪ The speed is 150 r/min or faster. ▪ The load to motor inertia ratio is 100 times or smaller. ▪ The acceleration/deceleration torque is 10% or higher of the rated torque. ● Under operating conditions which will impose sudden disturbance torque during acceleration or deceleration or on a machine which is extremely loose, auto tuning may not function properly, either. In such cases, use the auto tuning mode 2 or manual mode to make gain adjustment.

(2) Auto tuning mode 2

Use the auto tuning mode 2 when proper gain adjustment cannot be made by auto tuning mode 1. Since the load to motor inertia ratio is not estimated in this mode, set the value of a correct load to motor inertia ratio in [Pr. PB06].

The following parameters are automatically adjusted in the auto tuning mode 2.

Parameter	Symbol	Name
PB07	PG1	Model loop gain
PB08	PG2	Position loop gain
PB09	VG2	Speed loop gain
PB10	VIC	Speed integral compensation

6. NORMAL GAIN ADJUSTMENT

6.3.2 Auto tuning mode basis

The block diagram of real-time auto tuning is shown below.

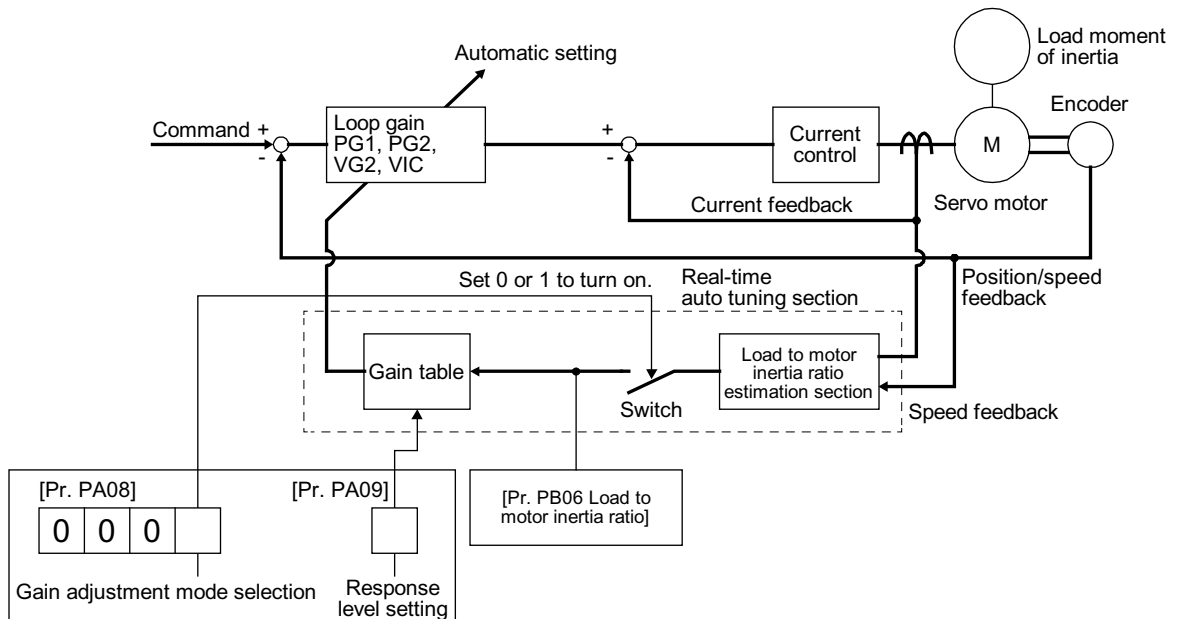

When a servo motor is accelerated or decelerated, the load to motor inertia ratio estimation section always estimates the load to motor inertia ratio from the current and speed of the servo motor. The results of the estimation are written to [Pr. PB06 Load to motor inertia ratio]. These results can be confirmed on the status display window of MR Configurator2.

If you have already known the value of the load to motor inertia ratio or failed to estimate, set "Gain adjustment mode selection" to "Auto tuning mode 2 (_ _ 2)" in [Pr. PA08] to stop the estimation (turning off the switch in the above diagram), and set the load to motor inertia ratio ([Pr. PB06]) manually.

From the preset load to motor inertia ratio ([Pr. PB06]) value and response ([Pr. PA09]), the optimum loop gains are automatically set on the basis of the internal gain table.

The auto tuning results are saved in the EEPROM of the servo amplifier every 60 minutes since power-on. At power-on, auto tuning is performed with the value of each loop gain saved in the EEPROM being used as an initial value.

POINT
<ul style="list-style-type: none"> ● If sudden disturbance torque is imposed during operation, the load to motor inertia ratio may be misestimated temporarily. In such a case, set "Gain adjustment mode selection" to "Auto tuning mode 2 (_ _ 2)" in [Pr. PA08] and then set the correct load to motor inertia ratio in [Pr. PB06]. ● When any of the auto tuning mode 1 and auto tuning mode 2 is changed to the manual mode, the current loop gains and load to motor inertia ratio estimation value are saved in the EEPROM.

6. NORMAL GAIN ADJUSTMENT

6.3.3 Adjustment procedure by auto tuning

Since auto tuning is enabled before shipment from the factory, simply running the servo motor automatically sets the optimum gains that match the machine. Merely changing the response level setting value as required completes the adjustment. The adjustment procedure is as follows.

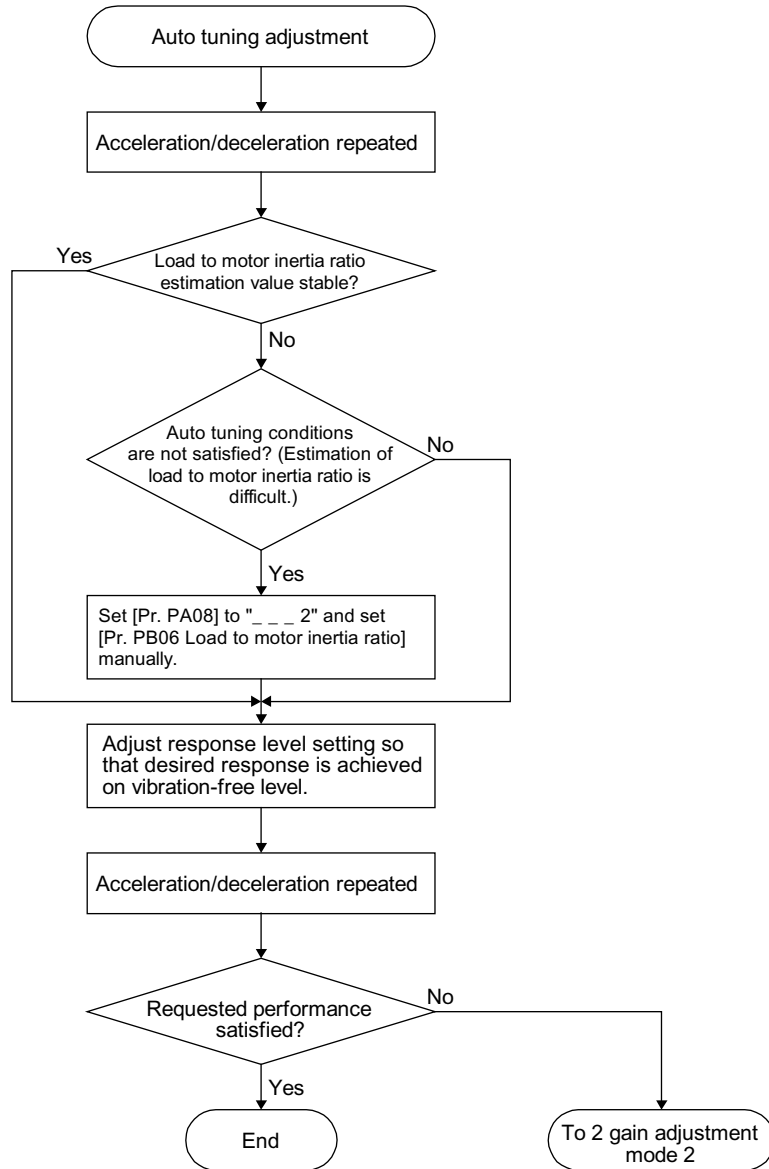

6. NORMAL GAIN ADJUSTMENT

6.3.4 Response level setting in auto tuning mode

Set the response of the whole servo system by [Pr. PA09]. As the response level setting is increased, the trackability to a command improves and settling time decreases, but setting the response level too high will generate vibration. Set a value to obtain the desired response level within the vibration-free range.

If the response level setting cannot be increased up to the desired response because of machine resonance beyond 100 Hz, filter tuning mode selection in [Pr. PB01] or machine resonance suppression filter in [Pr. PB13] to [Pr. PB16], and [Pr. PB46] to [Pr. PB51] may be used to suppress machine resonance.

Suppressing machine resonance may allow the response level setting to increase. Refer to section 7.1.1 and 7.1.2 for settings of the adaptive tuning mode and machine resonance suppression filter.

[Pr. PA09]

Setting value	Machine characteristic		Reference (setting value of MR-J3)
	Response	Guideline for the machine resonance frequency [Hz]	
1	Low response	2.7	
2		3.6	
3		4.9	
4		6.6	
5		10.0	1
6		11.3	2
7		12.7	3
8		14.3	4
9		16.1	5
10		18.1	6
11	20.4	7	
12	23.0	8	
13	25.9	9	
14	29.2	10	
15	32.9	11	
16	37.0	12	
17	41.7	13	
18	47.0	14	
19	Middle response	52.9	15
20		59.6	16

Setting value	Machine characteristic		Reference (setting value of MR-J3)
	Response	Guideline for the machine resonance frequency [Hz]	
21	Middle response	67.1	17
22		75.6	18
23		85.2	19
24		95.9	20
25		108.0	21
26		121.7	22
27		137.1	23
28		154.4	24
29		173.9	25
30		195.9	26
31	220.6	27	
32	248.5	28	
33	279.9	29	
34	315.3	30	
35	355.1	31	
36	400.0	32	
37	446.6		
38	501.2		
39	High response	571.5	
40		642.7	

6. NORMAL GAIN ADJUSTMENT

6.4 Manual mode

If you are not satisfied with the adjustment of auto tuning, you can adjust all gains manually.

POINT
<p>● If machine resonance occurs, filter tuning mode selection in [Pr. PB01] or machine resonance suppression filter in [Pr. PB13] to [Pr. PB16] and [Pr. PB46] to [Pr. PB51] may be used to suppress machine resonance. (Refer to section 7.1.1 and 7.1.2.)</p>

(1) For speed control

(a) Parameter

The following parameters are used for gain adjustment.

Parameter	Symbol	Name
PB06	GD2	Load to motor inertia ratio
PB07	PG1	Model loop gain
PB09	VG2	Speed loop gain
PB10	VIC	Speed integral compensation

(b) Adjustment procedure

Step	Operation	Description
1	Adjust gains briefly with auto tuning. Refer to section 6.3.3.	
2	Change the setting of auto tuning to the manual mode ([Pr. PA08]: __ _ 3).	
3	Set an estimated value to the load to motor inertia ratio. (If the estimate value with auto tuning is correct, setting change is not required.)	
4	Set a small value to the model loop gain. Set a large value to the speed integral compensation.	
5	Increase the speed loop gain within the vibration- and unusual noise-free range, and return the gain slightly if vibration takes place.	Increase the speed loop gain.
6	Decrease the speed integral compensation within the vibration-free range, and return the compensation slightly if vibration takes place.	Decrease the time constant of the speed integral compensation.
7	Increase the model loop gain, and return the gain slightly if overshoot takes place.	Increase the model loop gain.
8	If the gains cannot be increased due to mechanical system resonance or the like and the desired response cannot be achieved, response may be increased by suppressing resonance with the adaptive tuning mode or machine resonance suppression filter and then executing steps 3 to 7.	Suppression of machine resonance Refer to section 7.1.1 and 7.1.2.
9	While checking the motor status, fine-adjust each gain.	Fine adjustment

6. NORMAL GAIN ADJUSTMENT

(c) Parameter adjustment

1) [Pr. PB09 Speed loop gain]

This parameter determines the response level of the speed control loop. Increasing the setting increases the response level, but the mechanical system is liable to vibrate. The actual response frequency of the speed loop is as indicated in the following expression.

$$\text{Speed loop response frequency [Hz]} = \frac{\text{Speed loop gain}}{(1 + \text{Load to motor inertia ratio}) \times 2 \pi}$$

2) [Pr. PB10 Speed integral compensation]

To eliminate stationary deviation against a command, the speed control loop is under proportional integral control. For the speed integral compensation, set the time constant of this integral control. Increasing the setting lowers the response level. However, if the load to motor inertia ratio is large or the mechanical system has any vibratory element, the mechanical system is liable to vibrate unless the setting is increased to some degree. The guideline is as indicated in the following expression.

$$\text{Speed integral compensation setting [ms]} \geq \frac{2000 \text{ to } 3000}{\text{Speed loop gain}/(1 + \text{Load to motor inertia ratio})}$$

3) [Pr. PB07 Model loop gain]

This parameter determines the response level to a speed command. Increasing the value improves trackability to a speed command, but a too high value will make overshoot liable to occur at settling.

$$\text{Estimated model loop gain} \geq \frac{\text{Speed loop gain}}{(1 + \text{Load to motor inertia ratio})} \times \left(\frac{1}{4} \text{ to } \frac{1}{8} \right)$$

(2) For position control

(a) Parameter

The following parameters are used for gain adjustment.

Parameter	Symbol	Name
PB06	GD2	Load to motor inertia ratio
PB07	PG1	Model loop gain
PB08	PG2	Position loop gain
PB09	VG2	Speed loop gain
PB10	VIC	Speed integral compensation

6. NORMAL GAIN ADJUSTMENT

(b) Adjustment procedure

Step	Operation	Description
1	Adjust gains briefly with auto tuning. Refer to section 6.3.3.	
2	Change the setting of auto tuning to the manual mode ([Pr. PA08]: _ _ _ 3).	
3	Set an estimated value to the load to motor inertia ratio. (If the estimate value with auto tuning is correct, setting change is not required.)	
4	Set a small value to the model loop gain and the position loop gain. Set a large value to the speed integral compensation.	
5	Increase the speed loop gain within the vibration- and unusual noise-free range, and return the gain slightly if vibration takes place.	Increase the speed loop gain.
6	Decrease the speed integral compensation within the vibration-free range, and return the compensation slightly if vibration takes place.	Decrease the time constant of the speed integral compensation.
7	Increase the position loop gain, and return the gain slightly if vibration takes place.	Increase the position loop gain.
8	Increase the model loop gain, and return the gain slightly if overshoot takes place.	Increase the model loop gain.
9	If the gains cannot be increased due to mechanical system resonance or the like and the desired response cannot be achieved, response may be increased by suppressing resonance with the adaptive tuning mode or machine resonance suppression filter and then executing steps 3 to 8.	Suppression of machine resonance Section 7.1.1 and 7.1.2
10	While checking the settling characteristic and motor status, fine-adjust each gain.	Fine adjustment

(c) Parameter adjustment

1) [Pr. PB09 Speed loop gain]

This parameter determines the response level of the speed control loop. Increasing the setting increases the response level, but the mechanical system is liable to vibrate. The actual response frequency of the speed loop is as indicated in the following expression.

$$\text{Speed loop response frequency [Hz]} = \frac{\text{Speed loop gain}}{(1 + \text{Load to motor inertia ratio}) \times 2 \pi}$$

2) [Pr. PB10 Speed integral compensation]

To eliminate stationary deviation against a command, the speed control loop is under proportional integral control. For the speed integral compensation, set the time constant of this integral control. Increasing the setting lowers the response level. However, if the load to motor inertia ratio is large or the mechanical system has any vibratory element, the mechanical system is liable to vibrate unless the setting is increased to some degree. The guideline is as indicated in the following expression.

$$\text{Speed integral compensation setting [ms]} \leq \frac{2000 \text{ to } 3000}{\text{Speed loop gain}/(1 + \text{Load to motor inertia ratio})}$$

6. NORMAL GAIN ADJUSTMENT

3) [Pr. PB08 Position loop gain]

This parameter determines the response level to a disturbance to the position control loop. Increasing the position loop gain increases the response level to a disturbance, but the mechanical system is liable to vibrate.

$$\text{Position loop gain guideline} \propto \frac{\text{Speed loop gain}}{(1 + \text{Load to motor inertia ratio})} \times \left(\frac{1}{4} \text{ to } \frac{1}{8} \right)$$

4) [Pr. PB07 Model loop gain]

This parameter determines the response level to a position command. Increasing the value improves trackability to a position command, but a too high value will make overshoot liable to occur at settling.

$$\text{Estimated model loop gain} \propto \frac{\text{Speed loop gain}}{(1 + \text{Load to motor inertia ratio})} \times \left(\frac{1}{4} \text{ to } \frac{1}{8} \right)$$

6.5 2 gain adjustment mode

The 2 gain adjustment mode is used to match the position loop gains of the axes in the interpolation operation of servo motors of two or more axes for an X-Y table or the like. In this mode, manually set the model loop gain that determines command trackability. Other parameters for gain adjustment are set automatically.

(1) 2 gain adjustment mode 1

For the 2 gain adjustment mode 1, manually set the model loop gain that determines command trackability. The mode constantly estimates the load to motor inertia ratio, and automatically sets other parameters for gain adjustment to optimum gains using auto tuning response.

The following parameters are used for 2 gain adjustment mode 1.

(a) Automatically adjusted parameter

The following parameters are automatically adjusted by auto tuning.

Parameter	Symbol	Name
PB06	GD2	Load to motor inertia ratio
PB08	PG2	Position loop gain
PB09	VG2	Speed loop gain
PB10	VIC	Speed integral compensation

(b) Manually adjusted parameter

The following parameters are adjustable manually.

Parameter	Symbol	Name
PA09	RSP	Auto tuning response
PB07	PG1	Model loop gain

6. NORMAL GAIN ADJUSTMENT

(2) 2 gain adjustment mode 2

Use 2 gain adjustment mode 2 when proper gain adjustment cannot be made with 2 gain adjustment mode 1. Since the load to motor inertia ratio is not estimated in this mode, set the value of a proper load to motor inertia ratio in [Pr. PB06].

The following parameters are used for 2 gain adjustment mode 2.

(a) Automatically adjusted parameter

The following parameters are automatically adjusted by auto tuning.

Parameter	Symbol	Name
PB08	PG2	Position loop gain
PB09	VG2	Speed loop gain
PB10	VIC	Speed integral compensation

(b) Manually adjusted parameter

The following parameters are adjustable manually.

Parameter	Symbol	Name
PA09	RSP	Auto tuning response
PB06	GD2	Load to motor inertia ratio
PB07	PG1	Model loop gain

(3) Adjustment procedure of 2 gain adjustment mode

POINT
<p>● Set the same value in [Pr. PB07 Model loop gain] for the axis used in the 2 gain adjustment mode.</p>

Step	Operation	Description
1	Set the auto tuning mode.	Select the auto tuning mode 1.
2	During operation, increase the response level setting value in [Pr. PA09], and return the setting if vibration occurs.	Adjustment in auto tuning mode 1
3	Check value of the model loop gain and the load to motor inertia ratio in advance.	Check the upper setting limits.
4	Set the 2 gain adjustment mode 1 ([Pr. PA08]: _ _ _ 0).	Select the 2 gain adjustment mode 1 (interpolation mode).
5	When the load to motor inertia ratio is different from the design value, select the 2 gain adjustment mode 2 ([Pr. PA08]: _ _ _ 4) and then set the load to motor inertia ratio manually in [Pr. PB06].	Check the load to motor inertia ratio.
6	Set the model loop gain of all the axes to be interpolated to the same value. At that time, adjust the values to the setting value of the axis which has the smallest model loop gain.	Set model loop gain.
7	Considering the interpolation characteristic and motor status, fine-adjust the model loop gain and response level setting.	Fine adjustment

6. NORMAL GAIN ADJUSTMENT

(4) Parameter adjustment

[Pr. PB07 Model loop gain]

This parameter determines the response level of the position control loop. Increasing the value improves trackability to a position command, but a too high value will make overshoot liable to occur at settling.

Number of droop pulses is determined by the following expression.

$$\text{Number of droop pulses [pulse]} = \frac{\text{Position command frequency [pulse/s]}}{\text{Model loop gain setting}}$$

$$\text{Position command frequency} = \frac{\text{Speed [r/min]}}{60} \times \text{Encoder resolution (number of pulses per servo motor revolution)}$$

7. SPECIAL ADJUSTMENT FUNCTIONS

7. SPECIAL ADJUSTMENT FUNCTIONS

POINT
<ul style="list-style-type: none"> ● The functions given in this chapter need not be used normally. Use them if you are not satisfied with the machine status after making adjustment in the methods in chapter 6.

7.1 Filter setting

The following filters are available with MR-JE servo amplifiers.

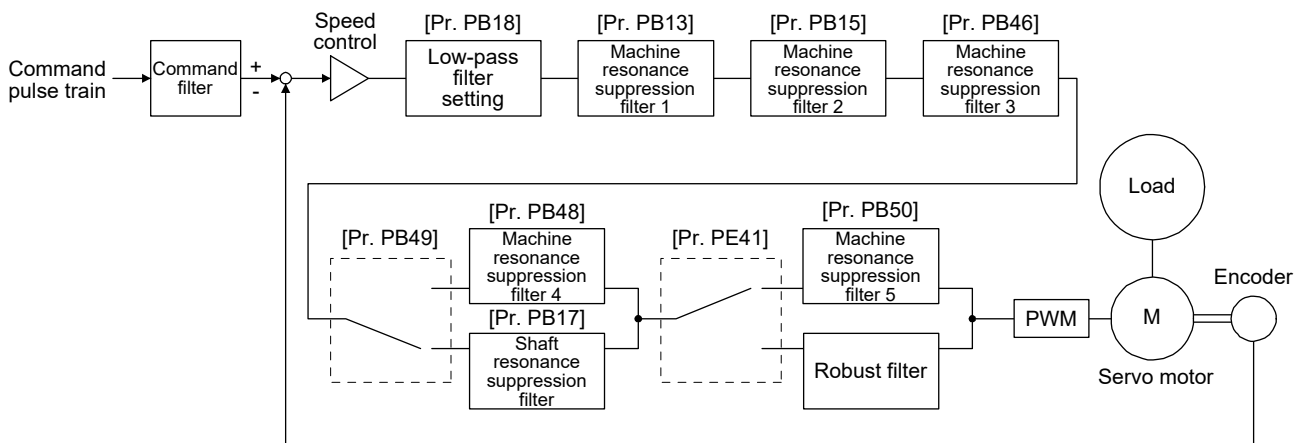

7.1.1 Machine resonance suppression filter

POINT
<ul style="list-style-type: none"> ● The machine resonance suppression filter is a delay factor for the servo system. Therefore, vibration may increase if you set an incorrect resonance frequency or set notch characteristics too deep or too wide. ● If the frequency of machine resonance is unknown, decrease the notch frequency from higher to lower ones in order. The optimum notch frequency is set at the point where vibration is minimal. ● A deeper notch has a higher effect on machine resonance suppression but increases a phase delay and may increase vibration. ● A wider notch has a higher effect on machine resonance suppression but increases a phase delay and may increase vibration. ● The machine characteristic can be grasped beforehand by the machine analyzer on MR Configurator2. This allows the required notch frequency and notch characteristics to be determined.

If a mechanical system has a unique resonance point, increasing the servo system response level may cause resonance (vibration or unusual noise) in the mechanical system at that resonance frequency. Using the machine resonance suppression filter and adaptive tuning can suppress the resonance of the mechanical system. The setting range is 10 Hz to 4500 Hz.

7. SPECIAL ADJUSTMENT FUNCTIONS

(1) Function

The machine resonance suppression filter is a filter function (notch filter) which decreases the gain of the specific frequency to suppress the resonance of the mechanical system. You can set the gain decreasing frequency (notch frequency), gain decreasing depth, and width.

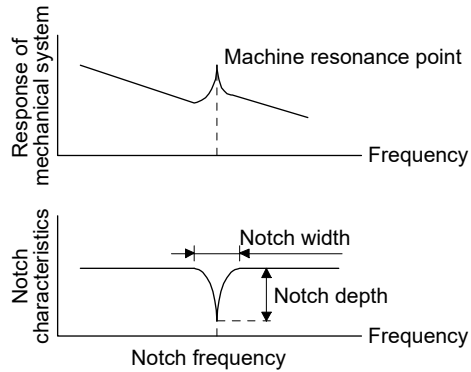

You can set five machine resonance suppression filters at most.

Filter	Setting parameter	Precaution	Parameter that is reset with vibration tough drive function	Parameter automatically adjusted with one-touch tuning
Machine resonance suppression filter 1	PB01/PB13/PB14	The filter can be set automatically with "Filter tuning mode selection" in [Pr. PB01].	PB13	PB01/PB13/PB14
Machine resonance suppression filter 2	PB15/PB16		PB15	PB15/PB16
Machine resonance suppression filter 3	PB46/PB47		PB46/PB47	
Machine resonance suppression filter 4	PB48/PB49	Enabling the machine resonance suppression filter 4 disables the shaft resonance suppression filter. Using the shaft resonance suppression filter is recommended because it is adjusted properly depending on the usage situation. The shaft resonance suppression filter is enabled for the initial setting.		PB48/PB49
Machine resonance suppression filter 5	PB50/PB51	Enabling the robust filter disables the machine resonance suppression filter 5. The robust filter is disabled for the initial setting.		PB51

7. SPECIAL ADJUSTMENT FUNCTIONS

(2) Parameter

(a) Machine resonance suppression filter 1 ([Pr. PB13] and [Pr. PB14])

Set the notch frequency, notch depth, and notch width of the machine resonance suppression filter 1 ([Pr. PB13] and [Pr. PB14]).

When you select "Manual setting (_ _ _ 2)" of "Filter tuning mode selection" in [Pr. PB01], the setting of the machine resonance suppression filter 1 is enabled.

(b) Machine resonance suppression filter 2 ([Pr. PB15] and [Pr. PB16])

To use this filter, select "Enabled (_ _ _ 1)" of "Machine resonance suppression filter 2 selection" in [Pr. PB16].

How to set the machine resonance suppression filter 2 ([Pr. PB15] and [Pr. PB16]) is the same as for the machine resonance suppression filter 1 ([Pr. PB13] and [Pr. PB14]).

(c) Machine resonance suppression filter 3 ([Pr. PB46] and [Pr. PB47])

To use this filter, select "Enabled (_ _ _ 1)" of "Machine resonance suppression filter 3 selection" in [Pr. PB47].

How to set the machine resonance suppression filter 3 ([Pr. PB46] and [Pr. PB47]) is the same as for the machine resonance suppression filter 1 ([Pr. PB13] and [Pr. PB14]).

(d) Machine resonance suppression filter 4 ([Pr. PB48] and [Pr. PB49])

To use this filter, select "Enabled (_ _ _ 1)" of "Machine resonance suppression filter 4 selection" in [Pr. PB49]. However, enabling the machine resonance suppression filter 4 disables the shaft resonance suppression filter.

How to set the machine resonance suppression filter 4 ([Pr. PB48] and [Pr. PB49]) is the same as for the machine resonance suppression filter 1 ([Pr. PB13] and [Pr. PB14]).

(e) Machine resonance suppression filter 5 ([Pr. PB50] and [Pr. PB51])

To use this filter, select "Enabled (_ _ _ 1)" of "Machine resonance suppression filter 5 selection" in [Pr. PB51]. However, enabling the robust filter ([Pr. PE41]: _ _ _ 1) disables the machine resonance suppression filter 5.

How to set the machine resonance suppression filter 5 ([Pr. PB50] and [Pr. PB51]) is the same as for the machine resonance suppression filter 1 ([Pr. PB13] and [Pr. PB14]).

7. SPECIAL ADJUSTMENT FUNCTIONS

7.1.2 Adaptive filter II

POINT
<ul style="list-style-type: none"> ● The machine resonance frequency which adaptive filter II (adaptive tuning) can respond to is about 100 Hz to 2.25 kHz. As for the resonance frequency out of the range, set manually. ● When adaptive tuning is executed, vibration sound increases as an excitation signal is forcibly applied for several seconds. ● When adaptive tuning is executed, machine resonance is detected for a maximum of 10 seconds and a filter is generated. After filter generation, the adaptive tuning mode automatically shifts to the manual setting. ● Adaptive tuning generates the optimum filter with the currently set control gains. If vibration occurs when the response setting is increased, execute adaptive tuning again. ● During adaptive tuning, a filter having the best notch depth at the set control gain is generated. To allow a filter margin against machine resonance, increase the notch depth in the manual setting. ● Adaptive vibration suppression control may provide no effect on a mechanical system which has complex resonance characteristics. ● Adaptive tuning in the high accuracy mode is available with servo amplifiers with software version C5 or later. The frequency is estimated more accurately in the high accuracy mode compared to the standard mode. However, the tuning sound may be larger in the high accuracy mode.

(1) Function

Adaptive filter II (adaptive tuning) is a function in which the servo amplifier detects machine vibration for a predetermined period of time and sets the filter characteristics automatically to suppress mechanical system vibration. Since the filter characteristics (frequency, depth) are set automatically, you need not be conscious of the resonance frequency of a mechanical system.

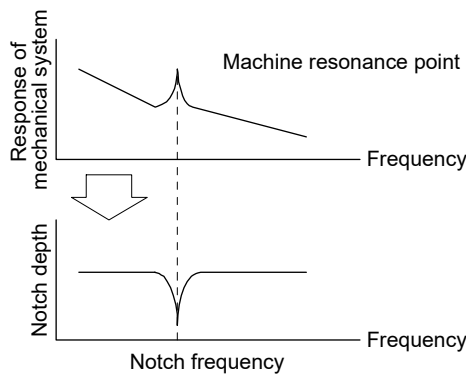

When machine resonance is large and frequency is low

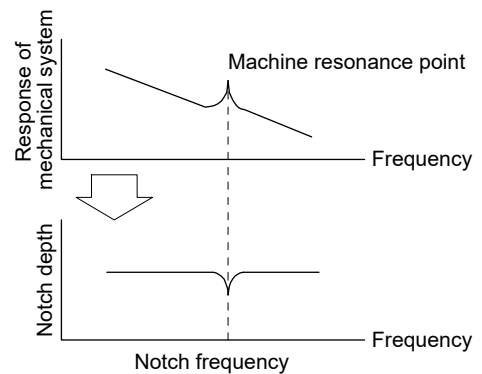

When machine resonance is small and frequency is high

7. SPECIAL ADJUSTMENT FUNCTIONS

(2) Parameter

Select how to set the filter tuning in [Pr. PB01 Adaptive tuning mode (adaptive filter II)].

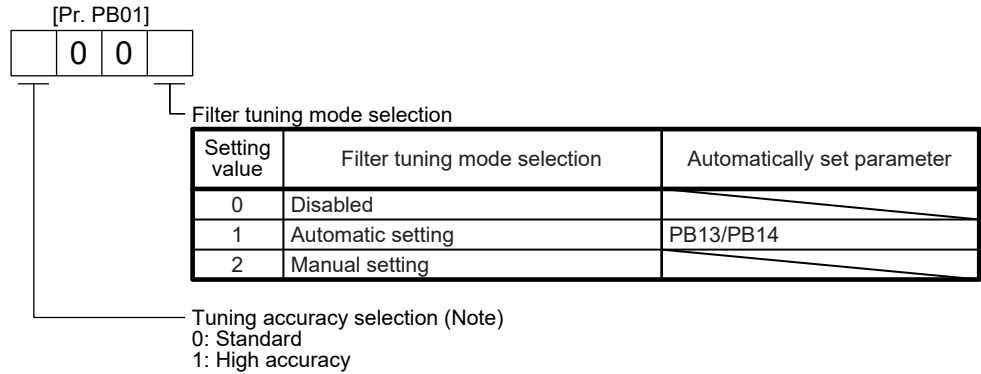

Note. This digit is available with servo amplifier with software version C5 or later.

(3) Adaptive tuning mode procedure

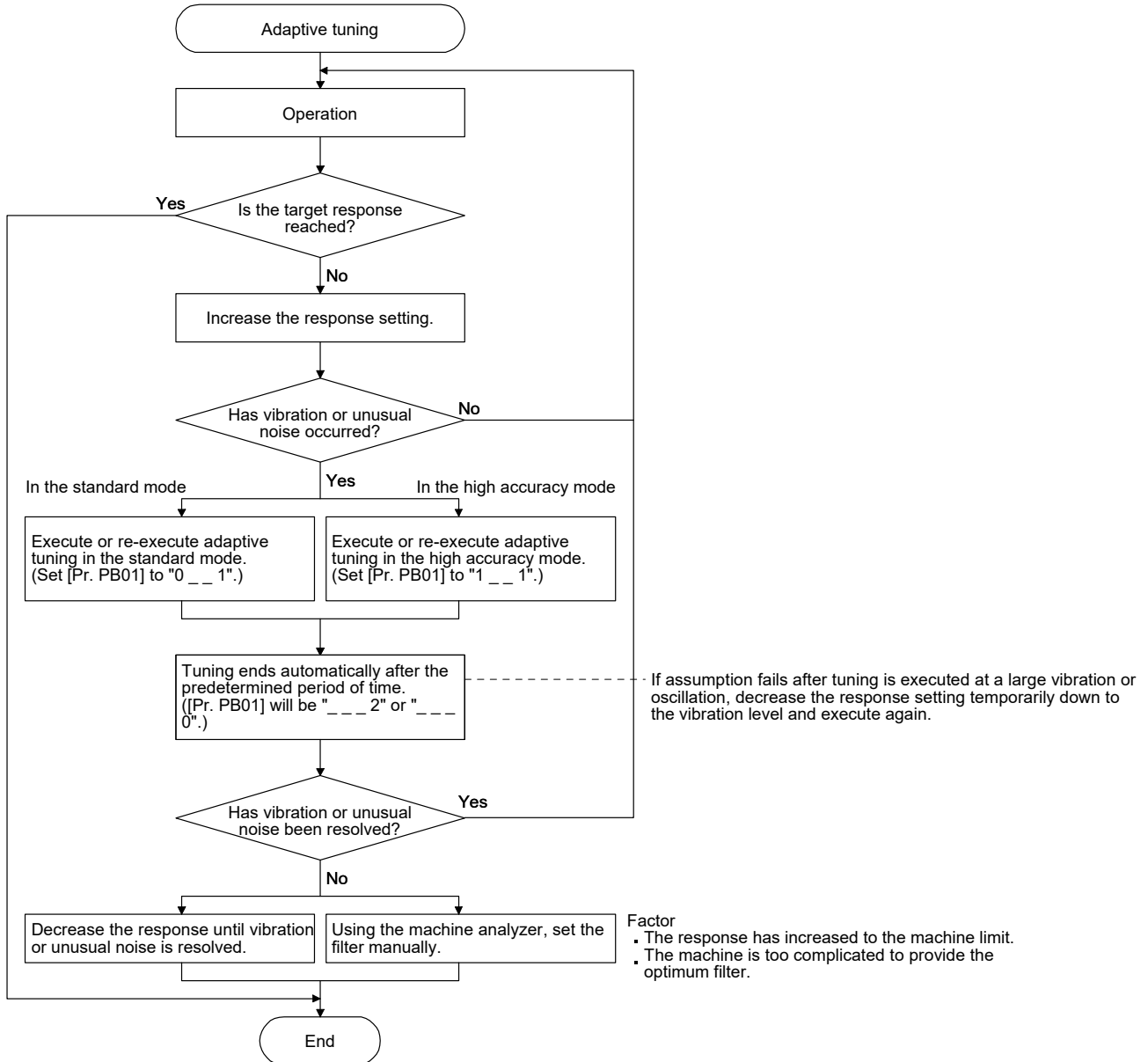

7. SPECIAL ADJUSTMENT FUNCTIONS

7.1.3 Shaft resonance suppression filter

POINT
<p>● This filter is set properly by default according to the servo motor you use and load moment of inertia. It is recommended that [Pr. PB23] be set to "___ 0" (automatic setting) because changing "Shaft resonance suppression filter selection" in [Pr. PB23] or [Pr. PB17 Shaft resonance suppression filter] may lower the performance.</p>

(1) Function

When a load is mounted to the servo motor shaft, resonance by shaft torsion during driving may generate a mechanical vibration at high frequency. The shaft resonance suppression filter suppresses the vibration.

When you select "Automatic setting", the filter will be set automatically on the basis of the servo motor you use and the load to motor inertia ratio. The disabled setting increases the response of the servo amplifier for high resonance frequency.

(2) Parameter

Set "Shaft resonance suppression filter selection" in [Pr. PB23].

[Pr. PB23]

0	0	0	
---	---	---	--

Shaft resonance suppression filter selection
 0: Automatic setting
 1: Manual setting
 2: Disabled

To set [Pr. PB17 Shaft resonance suppression filter] automatically, select "Automatic setting".
 To set [Pr. PB17 Shaft resonance suppression filter] manually, select "Manual setting". The setting values are as follows.

Shaft resonance suppression filter setting frequency selection

Setting value	Frequency [Hz]	Setting value	Frequency [Hz]
__ 0 0	Disabled	__ 1 0	562
__ 0 1	Disabled	__ 1 1	529
__ 0 2	4500	__ 1 2	500
__ 0 3	3000	__ 1 3	473
__ 0 4	2250	__ 1 4	450
__ 0 5	1800	__ 1 5	428
__ 0 6	1500	__ 1 6	409
__ 0 7	1285	__ 1 7	391
__ 0 8	1125	__ 1 8	375
__ 0 9	1000	__ 1 9	360
__ 0 A	900	__ 1 A	346
__ 0 B	818	__ 1 B	333
__ 0 C	750	__ 1 C	321
__ 0 D	692	__ 1 D	310
__ 0 E	642	__ 1 E	300
__ 0 F	600	__ 1 F	290

7. SPECIAL ADJUSTMENT FUNCTIONS

7.1.4 Low-pass filter

(1) Function

When a ball screw or the like is used, resonance of high frequency may occur as the response level of the servo system is increased. To prevent this, the low-pass filter is enabled for a torque command as the initial value. The filter frequency of the low-pass filter is automatically adjusted to the value in the following equation.

$$\text{Filter frequency ([rad/s])} = \frac{VG2}{1 + GD2} \times 8$$

However, when an automatically adjusted value is smaller than VG2, the filter frequency will be the VG2 value.

To set [Pr. PB18] manually, select "Manual setting (_ _ 1 _)" of "Low-pass filter selection" in [Pr. PB23].

(2) Parameter

Set "Low-pass filter selection" in [Pr. PB23].

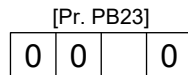

Low-pass filter selection
 0: Automatic setting
 1: Manual setting
 2: Disabled

7.1.5 Advanced vibration suppression control II

POINT
<ul style="list-style-type: none"> ● The function is enabled when "Gain adjustment mode selection" in [Pr. PA08] is "Auto tuning mode 2 (_ _ _ 2)", "Manual mode (_ _ _ 3)", or "2 gain adjustment mode 2 (_ _ _ 4)". ● The machine resonance frequency supported in the vibration suppression control tuning mode is 1.0 Hz to 100.0 Hz. As for the vibration out of the range, set manually. ● Stop the servo motor before changing the vibration suppression control-related parameters. Otherwise, it may cause an unexpected operation. ● For positioning operation during execution of vibration suppression control tuning, provide a stop time to ensure a stop after vibration damping. ● Vibration suppression control tuning may not make normal estimation if the residual vibration at the servo motor side is small. ● Vibration suppression control tuning sets the optimum parameter with the currently set control gains. When the response setting is increased, set vibration suppression control tuning again. ● When using the vibration suppression control 2, set " _ _ _ 1" in [Pr. PA24].

7. SPECIAL ADJUSTMENT FUNCTIONS

(1) Function

Vibration suppression control is used to further suppress load-side vibration, such as work-side vibration and base shake. The servo motor-side operation is adjusted for positioning so that the machine does not vibrate.

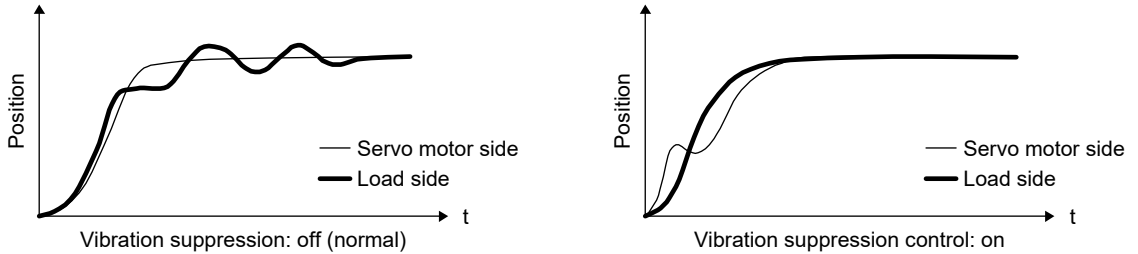

When the advanced vibration suppression control II ([Pr. PB02 Vibration suppression control tuning mode]) is executed, the vibration frequency at load side is automatically estimated to suppress machine side vibration two times at most.

In the vibration suppression control tuning mode, this mode shifts to the manual setting after the positioning operation is performed the predetermined number of times. For manual setting, adjust the vibration suppression control 1 with [Pr. PB19] to [Pr. PB22] and vibration suppression control 2 with [Pr. PB52] to [Pr. PB55].

(2) Parameter

Set [Pr. PB02 Vibration suppression control tuning mode (advanced vibration suppression control II)]. When you use a vibration suppression control, set "Vibration suppression control 1 tuning mode selection". When you use two vibration suppression controls, set "Vibration suppression control 2 tuning mode selection" in addition.

[Pr. PB02]
0 0

Vibration suppression control 1 tuning mode

Setting value	Vibration suppression control 1 tuning mode selection	Automatically set parameter
__ 0	Disabled	
__ 1	Automatic setting	PB19/PB20/PB21/PB22
__ 2	Manual setting	

Vibration suppression control 2 tuning mode

Setting value	Vibration suppression control 2 tuning mode selection	Automatically set parameter
__ 0	Disabled	
__ 1	Automatic setting	PB52/PB53/PB54/PB55
__ 2	Manual setting	

7. SPECIAL ADJUSTMENT FUNCTIONS

(3) Vibration suppression control tuning procedure

The following flow chart is for the vibration suppression control 1. For the vibration suppression control 2, set " __ 1 _ " in [Pr. PB02] to execute the vibration suppression control tuning.

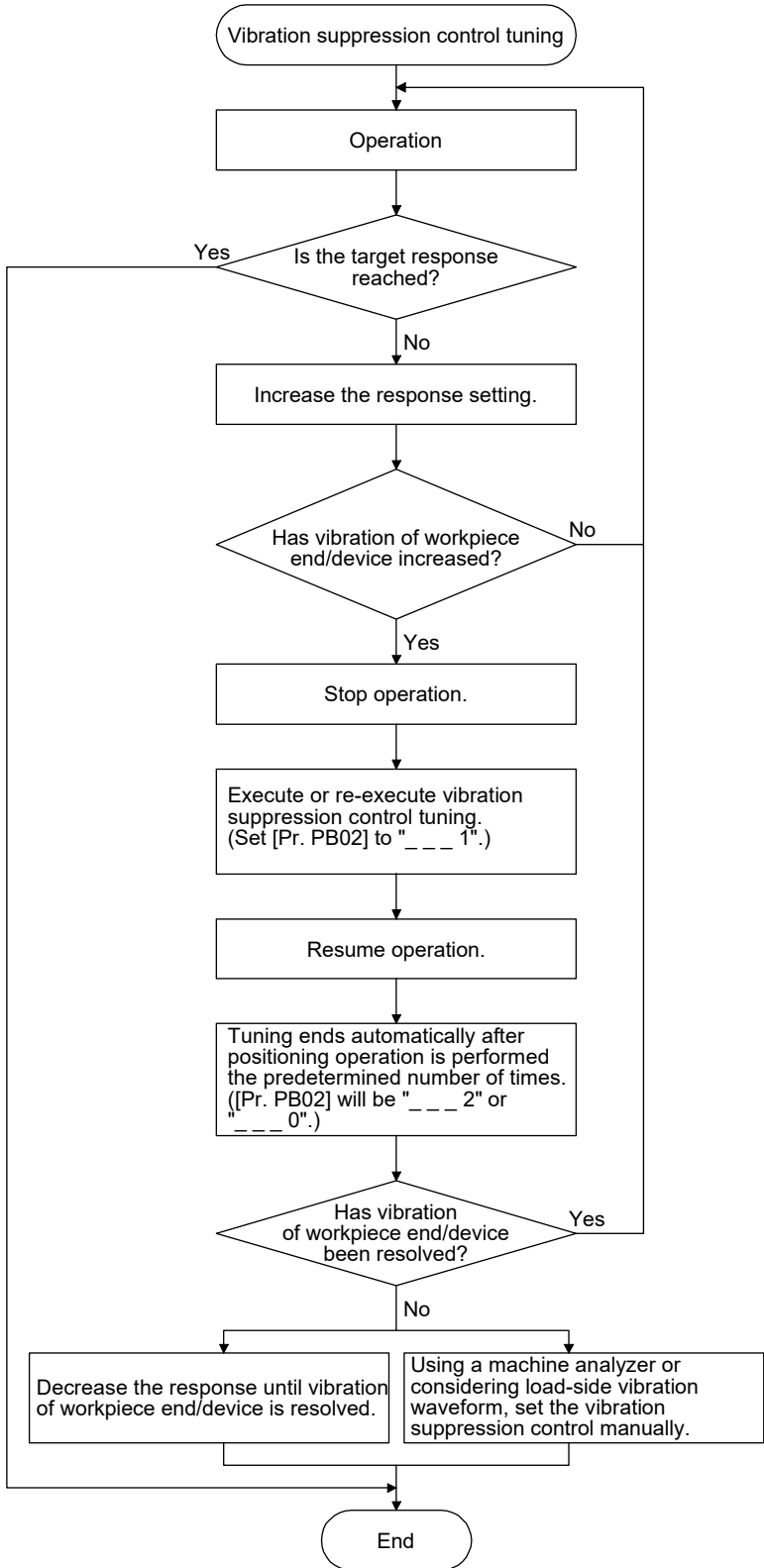

- Factor
- Estimation cannot be made as load-side vibration has not been transmitted to the servo motor side.
 - The model control gain value has reached the response level of the load-side vibration frequency (vibration suppression control limit).

7. SPECIAL ADJUSTMENT FUNCTIONS

(4) Vibration suppression control manual mode

POINT
<ul style="list-style-type: none"> ● When load-side vibration does not show up in servo motor-side vibration, the setting of the servo motor-side vibration frequency does not provide an effect. ● When the anti-resonance frequency and resonance frequency can be confirmed using the machine analyzer or external measuring instrument, do not set the same value but set different values to improve the vibration suppression performance. ● The setting range of [Pr. PB19], [Pr. PB20], [Pr. PB52], and [Pr. PB53] varies, depending on the value in [Pr. PB07]. If a value out of the range is set, the vibration suppression control will be disabled.

Measure work-side vibration and device shake with the machine analyzer or external measuring instrument, and set the following parameters to adjust vibration suppression control manually.

Setting item	Vibration suppression control 1	Vibration suppression control 2
Vibration frequency for vibration suppression control	[Pr. PB19]	[Pr. PB52]
Resonance frequency for vibration suppression control	[Pr. PB20]	[Pr. PB53]
Vibration suppression control - Vibration frequency damping	[Pr. PB21]	[Pr. PB54]
Vibration suppression control - Resonance frequency damping	[Pr. PB22]	[Pr. PB55]

Step 1. Select "Manual setting (_ _ 2)" of "Vibration suppression control 1 tuning mode selection" or "Manual setting (_ _ 2 _)" of "Vibration suppression control 2 tuning mode selection" in [Pr. PB02].

Step 2. Set "Vibration frequency for vibration suppression control" and "Resonance frequency for vibration suppression control" as follows.

However, the value of [Pr. PB07 Model loop gain], vibration frequency, and resonance frequency have the following usable range and recommended range.

Vibration suppression control	Usable range	Recommended setting range
Vibration suppression control 1	$[Pr. PB19] > 1/2\pi \times (0.9 \times [Pr. PB07])$ $[Pr. PB20] > 1/2\pi \times (0.9 \times [Pr. PB07])$	$[Pr. PB19] > 1/2\pi \times (1.5 \times [Pr. PB07])$ $[Pr. PB20] > 1/2\pi \times (1.5 \times [Pr. PB07])$
Vibration suppression control 2	When $[Pr. PB19] < [Pr. PB52]$, $[Pr. PB52] > (5.0 + 0.1 \times [Pr. PB07])$ $[Pr. PB53] > (5.0 + 0.1 \times [Pr. PB07])$ $1.1 < [Pr. PB52]/[Pr. PB19] < 5.5$ $[Pr. PB07] < 2\pi (0.3 \times [Pr. PB19] + 1/8 \times [Pr. PB52])$	When $[Pr. PB19] < [Pr. PB52]$, $[Pr. PB52], [Pr. PB53] > 6.25 \text{ Hz}$ $1.1 < [Pr. PB52]/[Pr. PB19] < 4$ $[Pr. PB07] < 1/3 \times (4 \times [Pr. PB19] + 2 \times [Pr. PB52])$

7. SPECIAL ADJUSTMENT FUNCTIONS

- (a) When a vibration peak can be confirmed with the machine analyzer using MR Configurator2, or external measuring instrument.

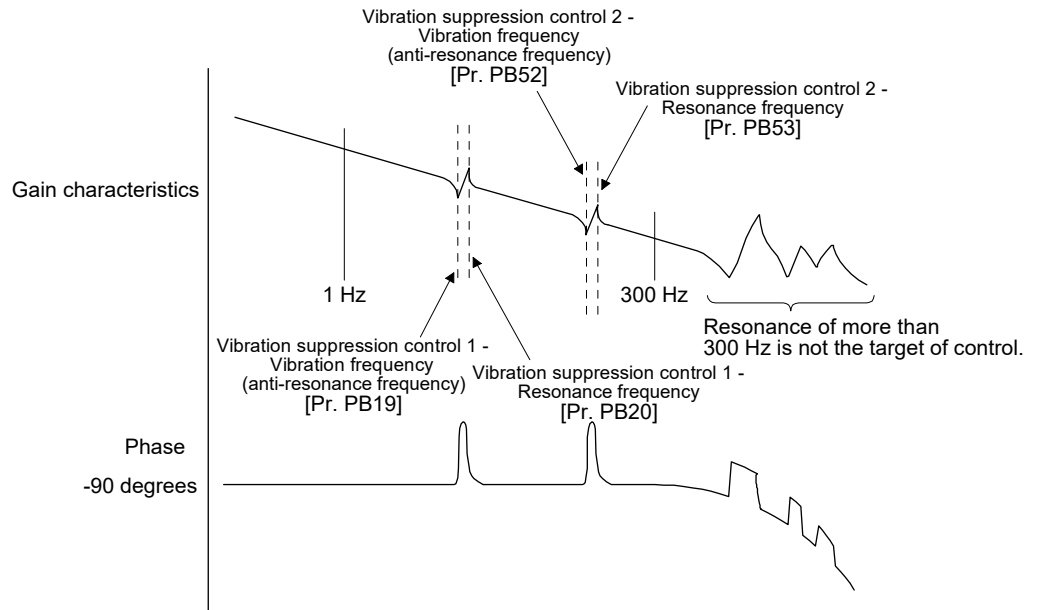

- (b) When vibration can be confirmed using monitor signal or external sensor

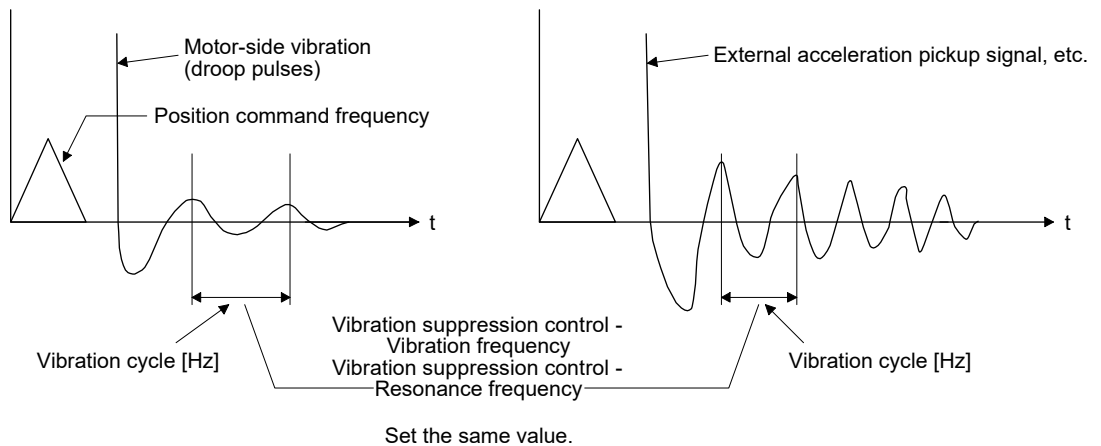

- Step 3. Fine-adjust "Vibration suppression control - Vibration frequency damping" and "Vibration suppression control - Resonance frequency damping".

7.1.6 Command notch filter

POINT
<ul style="list-style-type: none"> ● By using the advanced vibration suppression control II and the command notch filter, the load-side vibration of three frequencies can be suppressed. ● The frequency range of machine vibration, which can be supported by the command notch filter, is between 4.5 Hz and 2250 Hz. Set a frequency close to the machine vibration frequency and within the range. ● When [Pr. PB45 Command notch filter] is changed during the positioning operation, the changed setting is not reflected. The setting is reflected approximately 150 ms after the servo motor stops (after servo-lock).

7. SPECIAL ADJUSTMENT FUNCTIONS

(1) Function

Command notch filter has a function that lowers the gain of the specified frequency contained in a position command. By lowering the gain, load-side vibration, such as work-side vibration and base shake, can be suppressed. Which frequency to lower the gain and how deep to lower the gain can be set.

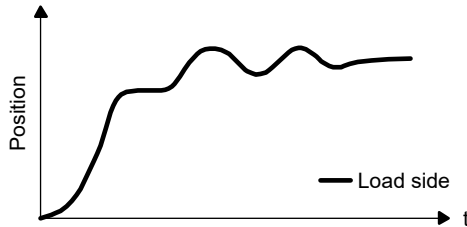

Command notch filter: disabled

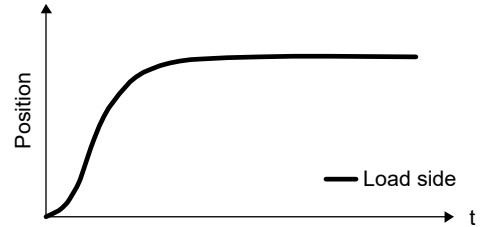

Command notch filter: enabled

(2) Parameter

Set [Pr. PB45 Command notch filter] as shown below. For the command notch filter setting frequency, set the closest value to the vibration frequency [Hz] at the load side.

[Pr. PB45]

0			
---	--	--	--

Notch depth

Setting value	Depth [dB]
0	-40.0
1	-24.1
2	-18.1
3	-14.5
4	-12.0
5	-10.1
6	-8.5
7	-7.2
8	-6.0
9	-5.0
A	-4.1
B	-3.3
C	-2.5
D	-1.8
E	-1.2
F	-0.6

Command notch filter setting frequency

Setting value	Frequency [Hz]	Setting value	Frequency [Hz]	Setting value	Frequency [Hz]
00	Disabled	20	70	40	17.6
01	2250	21	66	41	16.5
02	1125	22	62	42	15.6
03	750	23	59	43	14.8
04	562	24	56	44	14.1
05	450	25	53	45	13.4
06	375	26	51	46	12.8
07	321	27	48	47	12.2
08	281	28	46	48	11.7
09	250	29	45	49	11.3
0A	225	2A	43	4A	10.8
0B	204	2B	41	4B	10.4
0C	187	2C	40	4C	10.0
0D	173	2D	38	4D	9.7
0E	160	2E	37	4E	9.4
0F	150	2F	36	4F	9.1
10	140	30	35.2	50	8.8
11	132	31	33.1	51	8.3
12	125	32	31.3	52	7.8
13	118	33	29.6	53	7.4
14	112	34	28.1	54	7.0
15	107	35	26.8	55	6.7
16	102	36	25.6	56	6.4
17	97	37	24.5	57	6.1
18	93	38	23.4	58	5.9
19	90	39	22.5	59	5.6
1A	86	3A	21.6	5A	5.4
1B	83	3B	20.8	5B	5.2
1C	80	3C	20.1	5C	5.0
1D	77	3D	19.4	5D	4.9
1E	75	3E	18.8	5E	4.7
1F	72	3F	18.2	5F	4.5

7. SPECIAL ADJUSTMENT FUNCTIONS

7.2 Gain switching function

You can switch gains with the function. You can switch gains during rotation and during stop, and can use a control command from a controller to switch gains during operation.

7.2.1 Applications

The following shows when you use the function.

- (1) You want to increase the gains during servo-lock but decrease the gains to reduce noise during rotation.
- (2) You want to increase the gains during settling to shorten the stop settling time.
- (3) You want to change the gains using a control command from a controller to ensure stability of the servo system since the load to motor inertia ratio varies greatly during a stop (e.g. a large load is mounted on a carrier).

7. SPECIAL ADJUSTMENT FUNCTIONS

7.2.2 Function block diagram

The control gains, load to motor inertia ratio, and vibration suppression control settings are changed according to the conditions selected by [Pr. PB26 Gain switching function] and [Pr. PB27 Gain switching condition].

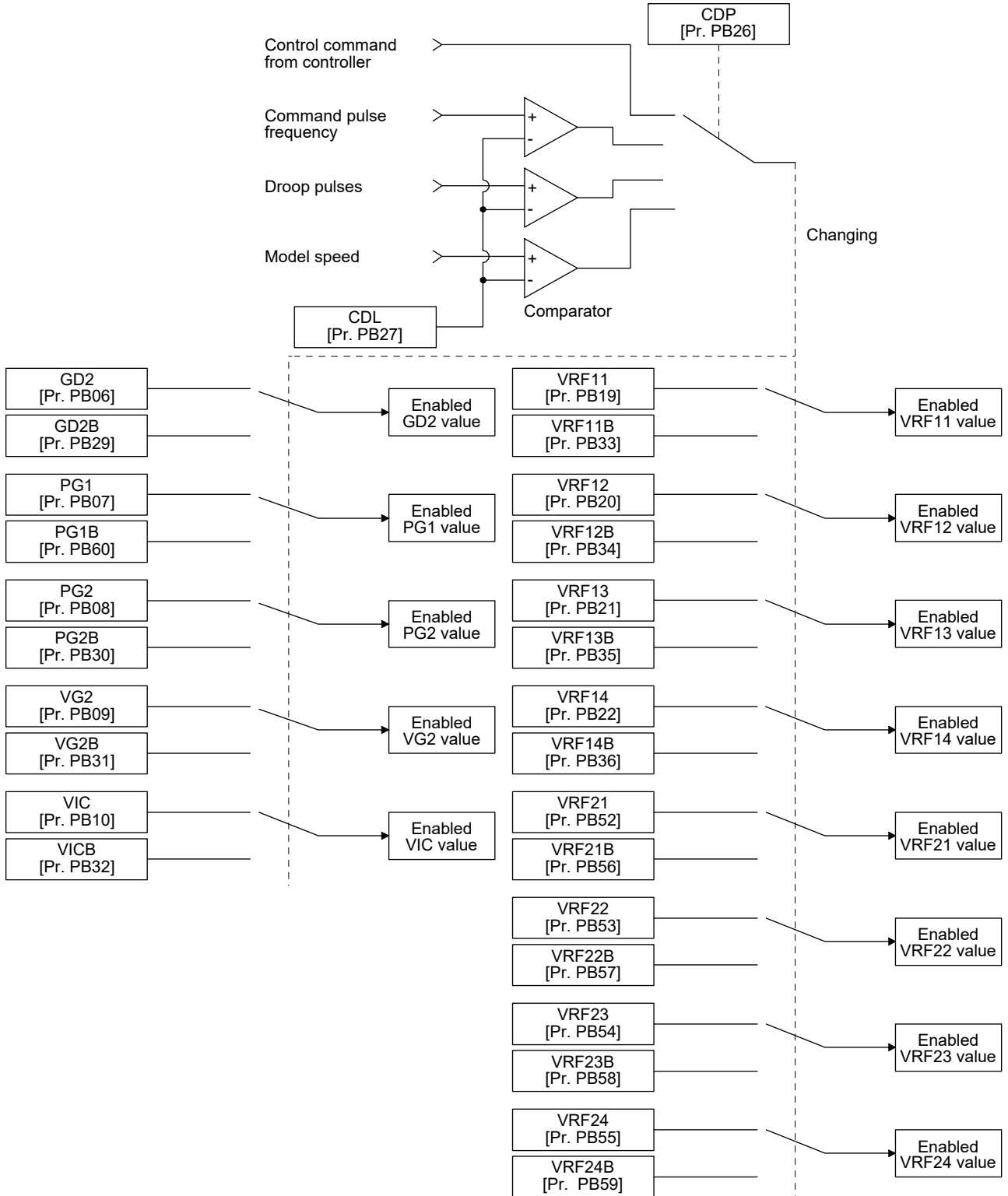

7. SPECIAL ADJUSTMENT FUNCTIONS

7.2.3 Parameter

When using the gain switching function, always select "Manual mode (_ _ _ 3)" of "Gain adjustment mode selection" in [Pr. PA08 Auto tuning mode]. The gain switching function cannot be used in the auto tuning mode.

(1) Parameters for setting gain switching condition

Parameter	Symbol	Name	Unit	Description
PB26	CDP	Gain switching function		Select a switching condition.
PB27	CDL	Gain switching condition	[kpulse/s] /[pulse] /[r/min]	Set a switching condition values.
PB28	CDT	Gain switching time constant	[ms]	Set the filter time constant for a gain change at changing.

(a) [Pr. PB26 Gain switching function]

This parameter is for setting of the gain switching conditions. Select the switching condition in the first to third digits.

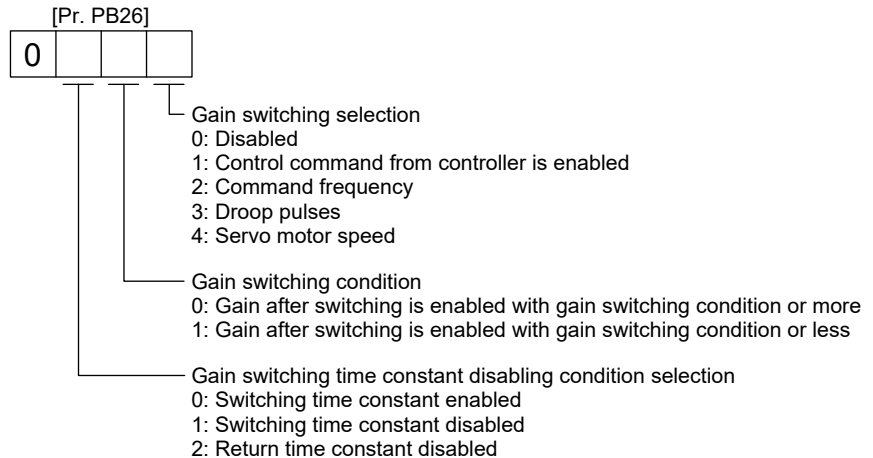

(b) [Pr. PB27 Gain switching condition]

Set a level to switch gains with [Pr. PB27] after you select "Command frequency", "Droop pulses", or "Servo motor speed" in the gain switching selection in [Pr. PB26 Gain switching function].

The setting unit is as follows.

Gain switching condition	Unit
Command frequency	[kpulse/s]
Droop pulses	[pulse]
Servo motor speed	[r/min]

(c) [Pr. PB28 Gain switching time constant]

You can set the primary delay filter to each gain at gain switching. Use this parameter to suppress shock given to the machine if the gain difference is large at gain switching, for example.

7. SPECIAL ADJUSTMENT FUNCTIONS

(2) Switchable gain parameter

Loop gain	Before switching			After switching		
	Parameter	Symbol	Name	Parameter	Symbol	Name
Load to motor inertia ratio	PB06	GD2	Load to motor inertia ratio	PB29	GD2B	Load to motor inertia ratio after gain switching
Model loop gain	PB07	PG1	Model loop gain	PB60	PG1B	Model loop gain after gain switching
Position loop gain	PB08	PG2	Position loop gain	PB30	PG2B	Position loop gain after gain switching
Speed loop gain	PB09	VG2	Speed loop gain	PB31	VG2B	Speed loop gain after gain switching
Speed integral compensation	PB10	VIC	Speed integral compensation	PB32	VICB	Speed integral compensation after gain switching
Vibration suppression control 1 - Vibration frequency	PB19	VRF11	Vibration suppression control 1 - Vibration frequency	PB33	VRF11B	Vibration suppression control 1 - Vibration frequency after gain switching
Vibration suppression control 1 - Resonance frequency	PB20	VRF12	Vibration suppression control 1 - Resonance frequency	PB34	VRF12B	Vibration suppression control 1 - Resonance frequency after gain switching
Vibration suppression control 1 - Vibration frequency damping	PB21	VRF13	Vibration suppression control 1 - Vibration frequency damping	PB35	VRF13B	Vibration suppression control 1 - Vibration frequency damping after gain switching
Vibration suppression control 1 - Resonance frequency damping	PB22	VRF14	Vibration suppression control 1 - Resonance frequency damping	PB36	VRF14B	Vibration suppression control 1 - Resonance frequency damping after gain switching
Vibration suppression control 2 - Vibration frequency	PB52	VRF21	Vibration suppression control 2 - Vibration frequency	PB56	VRF21B	Vibration suppression control 2 - Vibration frequency after gain switching
Vibration suppression control 2 - Resonance frequency	PB53	VRF22	Vibration suppression control 2 - Resonance frequency	PB57	VRF22B	Vibration suppression control 2 - Resonance frequency after gain switching
Vibration suppression control 2 - Vibration frequency damping	PB54	VRF23	Vibration suppression control 2 - Vibration frequency damping	PB58	VRF23B	Vibration suppression control 2 - Vibration frequency damping after gain switching
Vibration suppression control 2 - Resonance frequency damping	PB55	VRF24	Vibration suppression control 2 - Resonance frequency damping	PB59	VRF24B	Vibration suppression control 2 - Resonance frequency damping after gain switching

7. SPECIAL ADJUSTMENT FUNCTIONS

(a) [Pr. PB06] to [Pr. PB10]

These parameters are the same as in ordinary manual adjustment. Gain switching allows the values of load to motor inertia ratio, position loop gain, model loop gain, speed loop gain, and speed integral compensation to be switched.

(b) [Pr. PB19] to [Pr. PB22]/[Pr. PB52] to [Pr. PB55]

These parameters are the same as in ordinary manual adjustment. You can switch the vibration frequency, resonance frequency, vibration frequency damping, and resonance frequency damping by switching gain during motor stop.

(c) [Pr. PB29 Load to motor inertia ratio after gain switching]

Set the load to motor inertia ratio after gain switching. If the load to motor inertia ratio does not change, set it to the same value as [Pr. PB06 Load to motor inertia ratio].

(d) [Pr. PB30 Position loop gain after gain switching], [Pr. PB31 Speed loop gain after gain switching], and [Pr. PB32 Speed integral compensation after gain switching]

Set the values of after switching position loop gain, speed loop gain and speed integral compensation.

(e) Vibration suppression control after gain switching ([Pr. PB33] to [Pr. PB36]/[Pr. PB56] to [Pr. PB59])/[Pr. PB60 Model loop gain after gain switching]

The gain switching vibration suppression control and gain switching model loop gain are used only with a control command from the controller.

You can switch the vibration frequency, resonance frequency, vibration frequency damping, resonance frequency damping, and model loop gain of the vibration suppression control 1 and vibration suppression control 2.

7. SPECIAL ADJUSTMENT FUNCTIONS

7.2.4 Gain switching procedure

This operation will be described by way of setting examples.

(1) When you choose switching by a control command from the controller

(a) Setting example

Parameter	Symbol	Name	Setting value	Unit
PB06	GD2	Load to motor inertia ratio	4.00	[Multiplier]
PB07	PG1	Model loop gain	100	[rad/s]
PB08	PG2	Position loop gain	120	[rad/s]
PB09	VG2	Speed loop gain	3000	[rad/s]
PB10	VIC	Speed integral compensation	20	[ms]
PB19	VRF11	Vibration suppression control 1 - Vibration frequency	50	[Hz]
PB20	VRF12	Vibration suppression control 1 - Resonance frequency	50	[Hz]
PB21	VRF13	Vibration suppression control 1 - Vibration frequency damping	0.20	
PB22	VRF14	Vibration suppression control 1 - Resonance frequency damping	0.20	
PB52	VRF21	Vibration suppression control 2 - Vibration frequency	20	[Hz]
PB53	VRF22	Vibration suppression control 2 - Resonance frequency	20	[Hz]
PB54	VRF23	Vibration suppression control 2 - Vibration frequency damping	0.10	
PB55	VRF24	Vibration suppression control 2 - Resonance frequency damping	0.10	
PB29	GD2B	Load to motor inertia ratio after gain switching	10.00	[Multiplier]
PB60	PG1B	Model loop gain after gain switching	50	[rad/s]
PB30	PG2B	Position loop gain after gain switching	84	[rad/s]
PB31	VG2B	Speed loop gain after gain switching	4000	[rad/s]
PB32	VICB	Speed integral compensation after gain switching	50	[ms]
PB26	CDP	Gain switching function	0001 (Switch by control command from the controller.)	
PB28	CDT	Gain switching time constant	100	[ms]
PB33	VRF11B	Vibration suppression control 1 - Vibration frequency after gain switching	60	[Hz]
PB34	VRF12B	Vibration suppression control 1 - Resonance frequency after gain switching	60	[Hz]
PB35	VRF13B	Vibration suppression control 1 - Vibration frequency damping after gain switching	0.15	
PB36	VRF14B	Vibration suppression control 1 - Resonance frequency damping after gain switching	0.15	
PB56	VRF21B	Vibration suppression control 2 - Vibration frequency after gain switching	30	[Hz]
PB57	VRF22B	Vibration suppression control 2 - Resonance frequency after gain switching	30	[Hz]
PB58	VRF23B	Vibration suppression control 2 - Vibration frequency damping after gain switching	0.05	
PB59	VRF24B	Vibration suppression control 2 - Resonance frequency damping after gain switching	0.05	

7. SPECIAL ADJUSTMENT FUNCTIONS

(b) Switching timing chart

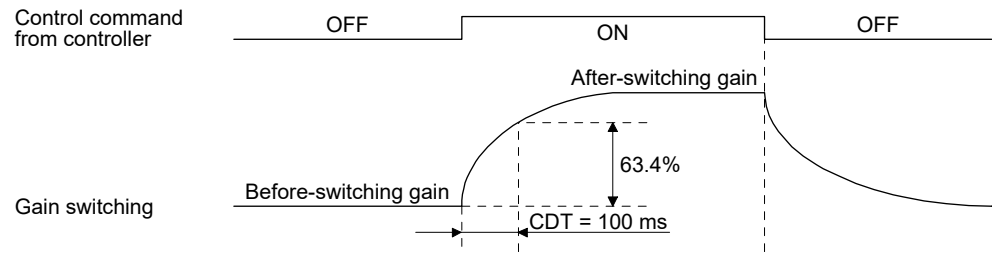

Model loop gain	100	→	50	→	100
Load to motor inertia ratio	4.00	→	10.00	→	4.00
Position loop gain	120	→	84	→	120
Speed loop gain	3000	→	4000	→	3000
Speed integral compensation	20	→	50	→	20
Vibration suppression control 1 - Vibration frequency	50	→	60	→	50
Vibration suppression control 1 - Resonance frequency	50	→	60	→	50
Vibration suppression control 1 - Vibration frequency damping	0.20	→	0.15	→	0.20
Vibration suppression control 1 - Resonance frequency damping	0.20	→	0.15	→	0.20
Vibration suppression control 2 - Vibration frequency	20	→	30	→	20
Vibration suppression control 2 - Resonance frequency	20	→	30	→	20
Vibration suppression control 2 - Vibration frequency damping	0.10	→	0.05	→	0.10
Vibration suppression control 2 - Resonance frequency damping	0.10	→	0.05	→	0.10

(2) When you choose switching by droop pulses

The vibration suppression control after gain switching and model loop gain after gain switching cannot be used.

(a) Setting example

Parameter	Symbol	Name	Setting value	Unit
PB06	GD2	Load to motor inertia ratio	4.00	[Multiplier]
PB08	PG2	Position loop gain	120	[rad/s]
PB09	VG2	Speed loop gain	3000	[rad/s]
PB10	VIC	Speed integral compensation	20	[ms]
PB29	GD2B	Load to motor inertia ratio after gain switching	10.00	[Multiplier]
PB30	PG2B	Position loop gain after gain switching	84	[rad/s]
PB31	VG2B	Speed loop gain after gain switching	4000	[rad/s]
PB32	VICB	Speed integral compensation after gain switching	50	[ms]
PB26	CDP	Gain switching function	0003 (switching by droop pulses)	
PB27	CDL	Gain switching condition	50	[pulse]
PB28	CDT	Gain switching time constant	100	[ms]

7. SPECIAL ADJUSTMENT FUNCTIONS

(b) Switching timing chart

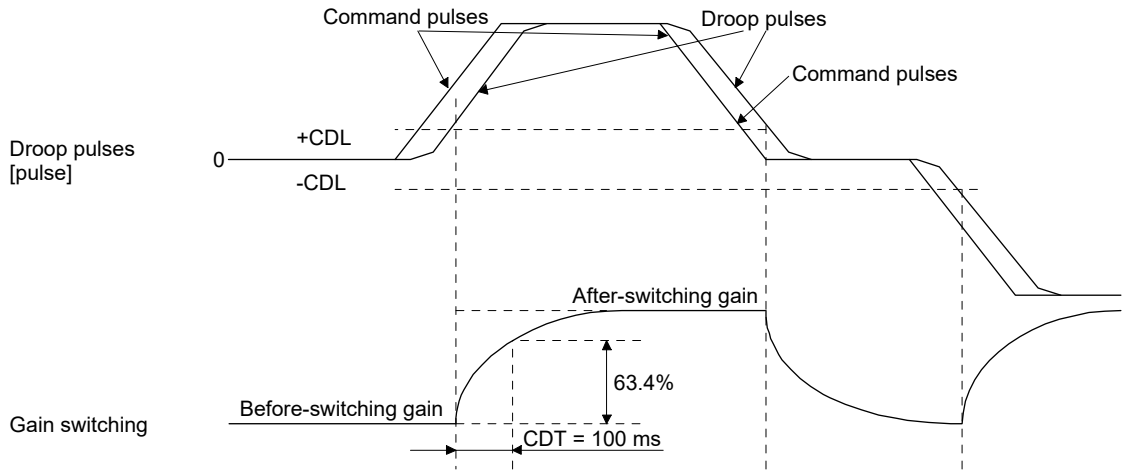

Load to motor inertia ratio	4.00	→	10.00	→	4.00	→	10.00
Position loop gain	120	→	84	→	120	→	84
Speed loop gain	3000	→	4000	→	3000	→	4000
Speed integral compensation	20	→	50	→	20	→	50

(3) When the gain switching time constant is disabled

(a) Switching time constant disabled was selected.

The gain switching time constant is disabled. The time constant is enabled at gain return.

The following example shows for [Pr. PB26 (CDP)] = 0103, [Pr. PB27 (CDL)] = 100 [pulse], and [Pr. PB28 (CDT)] = 100 [ms].

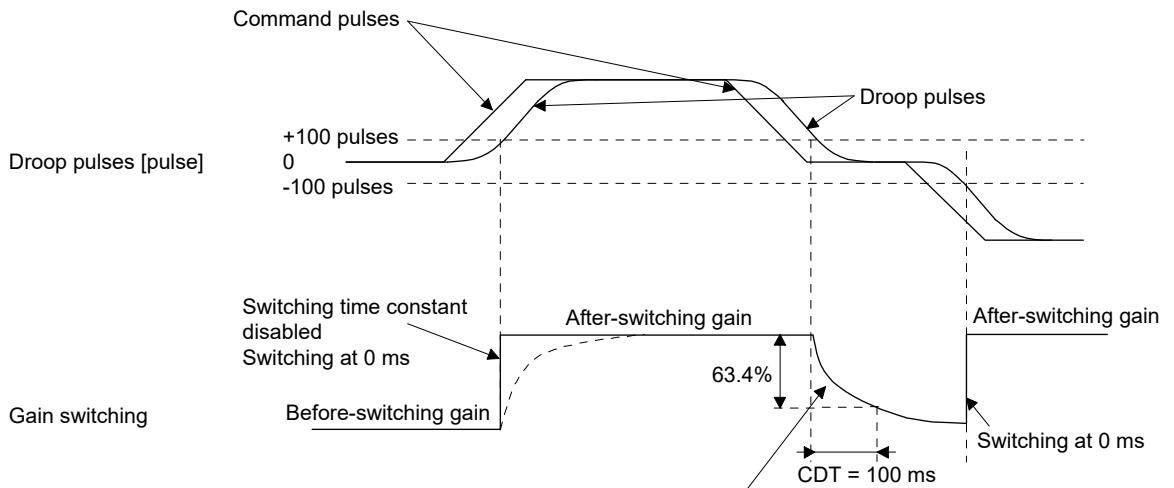

Switching at [Pr. PB28 (CDT)] = 100 [ms] only when gain switching off (when returning)

7. SPECIAL ADJUSTMENT FUNCTIONS

(b) Return time constant disabled was selected.

The gain switching time constant is enabled. The time constant is disabled at gain return.

The following example shows for [Pr. PB26 (CDP)] = 0201, [Pr. PB27 (CDL)] = 0, and [Pr. PB28 (CDT)] = 100 [ms].

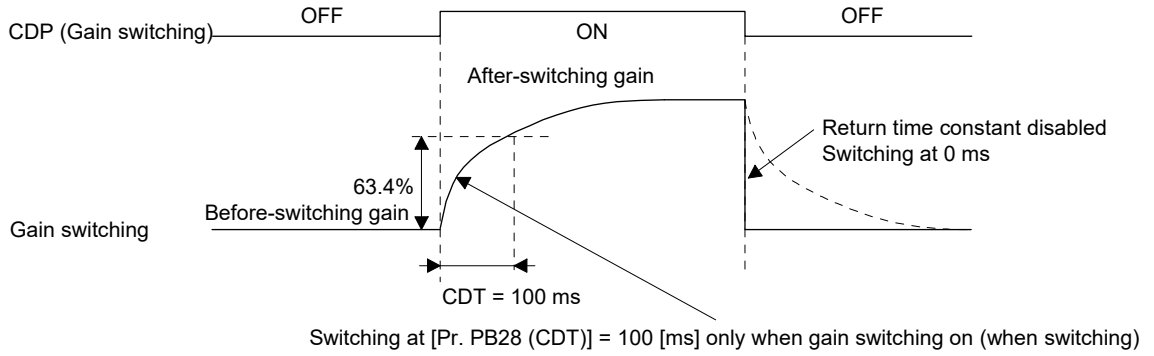

7. SPECIAL ADJUSTMENT FUNCTIONS

7.3 Tough drive function

POINT
● Enable or disable the tough drive function with [Pr. PA20 Tough drive setting]. (Refer to section 5.2.1.)

This function makes the equipment continue operating even under the condition that an alarm occurs. The tough drive function includes two types: the vibration tough drive and the instantaneous power failure tough drive.

7.3.1 Vibration tough drive function

This function prevents vibration by resetting a filter instantaneously when machine resonance occurs due to varied vibration frequency caused by machine aging.

To reset the machine resonance suppression filters with the function, [Pr. PB13 Machine resonance suppression filter 1] and [Pr. PB15 Machine resonance suppression filter 2] should be set in advance. Set [Pr. PB13] and [Pr. PB15] as follows.

- (1) One-touch tuning execution (section 6.2)
- (2) Manual setting (section 5.2.2)

The vibration tough drive function operates when a detected machine resonance frequency is within $\pm 30\%$ for a value set in [Pr. PB13 Machine resonance suppression filter 1] or [Pr. PB15 Machine resonance suppression filter 2].

To set a detection level of the function, set sensitivity in [Pr. PF23 Vibration tough drive - Oscillation detection level].

POINT
● Resetting [Pr. PB13] and [Pr. PB15] by the vibration tough drive function is performed constantly. However, the number of write times to the EEPROM is limited to once per hour.
● The vibration tough drive function does not reset [Pr. PB46 Machine resonance suppression filter 3], [Pr. PB48 Machine resonance suppression filter 4], and [Pr. PB50 Machine resonance suppression filter 5].
● The vibration tough drive function does not detect a vibration of 100 Hz or lower.

7. SPECIAL ADJUSTMENT FUNCTIONS

The following shows the function block diagram of the vibration tough drive function. The function detects machine resonance frequency and compares it with [Pr. PB13] and [Pr. PB15], and resets a machine resonance frequency of a parameter whose set value is closer.

Filter	Setting parameter	Precaution	Parameter that is reset with vibration tough drive function
Machine resonance suppression filter 1	PB01/PB13/PB14	The filter can be set automatically with "Filter tuning mode selection" in [Pr. PB01].	PB13
Machine resonance suppression filter 2	PB15/PB16		PB15
Machine resonance suppression filter 3	PB46/PB47		
Machine resonance suppression filter 4	PB48/PB49	Enabling the machine resonance suppression filter 4 disables the shaft resonance suppression filter. Using the shaft resonance suppression filter is recommended because it is adjusted properly depending on the usage situation. The shaft resonance suppression filter is enabled for the initial setting.	
Machine resonance suppression filter 5	PB50/PB51	Enabling the robust filter disables the machine resonance suppression filter 5. The robust filter is disabled for the initial setting.	

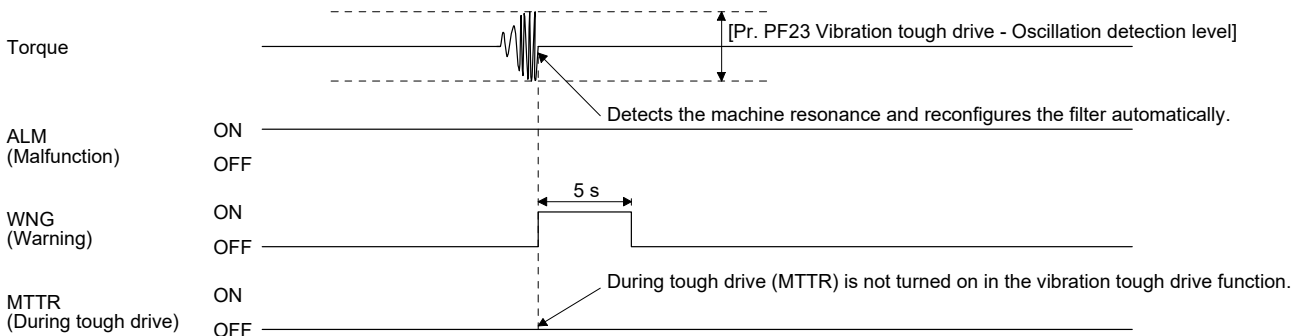
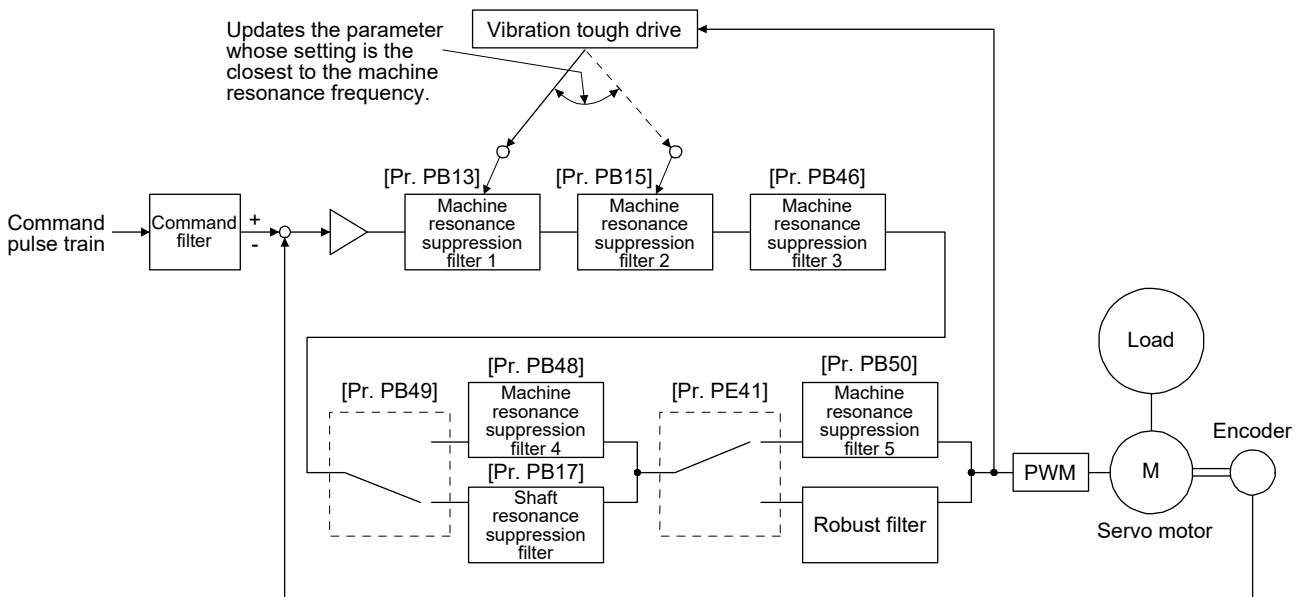

7. SPECIAL ADJUSTMENT FUNCTIONS

7.3.2 Instantaneous power failure tough drive function

The instantaneous power failure tough drive function avoids [AL. 10 Undervoltage] even when an instantaneous power failure occurs during operation. When the instantaneous power failure tough drive activates, the function will increase the tolerance against instantaneous power failures using the electrical energy charged in the capacitor in the servo amplifier and will change an alarm level of [AL. 10 Undervoltage] simultaneously. The [AL. 10.1 Voltage drop in the power] detection time for the power supply can be changed by [Pr. PF25 Instantaneous power failure tough drive - Detection time].

POINT
<ul style="list-style-type: none"> ● MBR (Electromagnetic brake interlock) will not turn off during the instantaneous power failure tough drive. ● Selecting "Enabled (_ _ _ 1)" for "Torque limit function selection at instantaneous power failure" in [Pr. PA26] will limit torques to save electric energy when an instantaneous power failure occurs during operation and will make [AL. 10 Undervoltage] less likely to occur. ● When the load of instantaneous power failure is large, [AL. 10.2] caused by the bus voltage drop may occur regardless of the set value of [Pr. PF25 Instantaneous power failure tough drive - Detection time].

(1) Instantaneous power failure time > [Pr. PF25 Instantaneous power failure tough drive - Detection time]

The alarm occurs when the instantaneous power failure time exceeds [Pr. PF25 Instantaneous power failure tough drive - Detection time].

MTTR (During tough drive) turns on after the instantaneous power failure is detected.

MBR (Electromagnetic brake interlock) turns off when the alarm occurs.

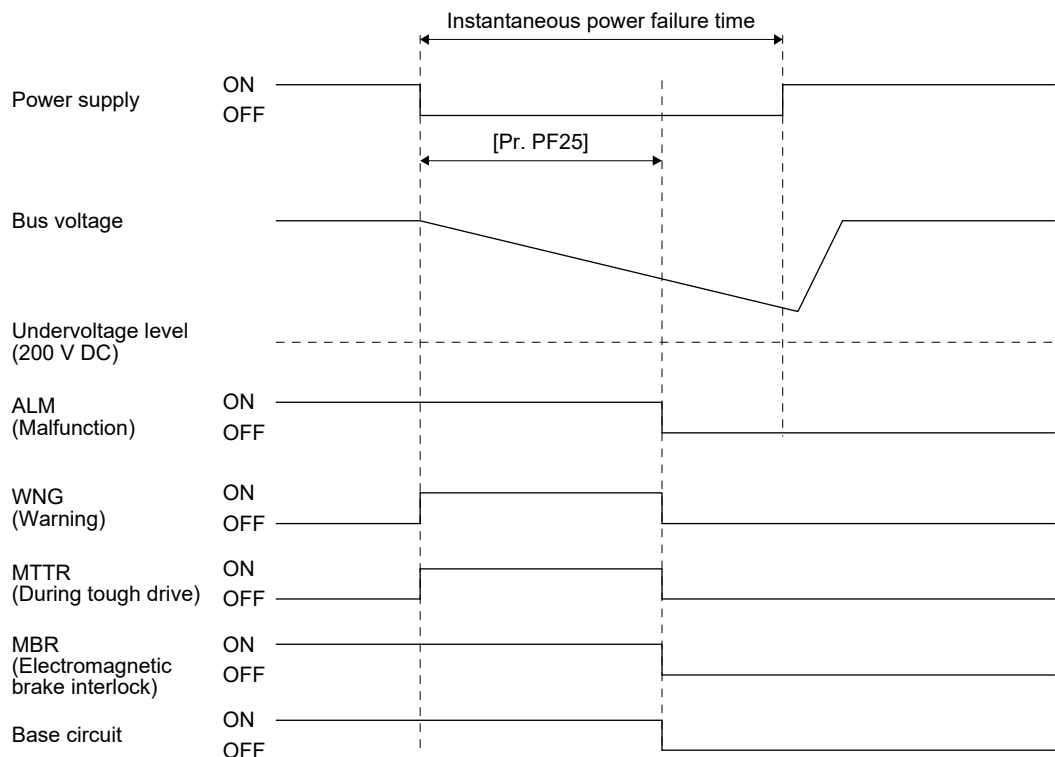

7. SPECIAL ADJUSTMENT FUNCTIONS

(2) Instantaneous power failure time < [Pr. PF25 Instantaneous power failure tough drive - Detection time]
 Operation status differs depending on how bus voltage decreases.

(a) When the bus voltage decreases to 200 V DC or lower within the instantaneous power failure time [AL. 10 Undervoltage] occurs when the bus voltage decreases to the undervoltage level or lower regardless of the enabled instantaneous power failure tough drive.

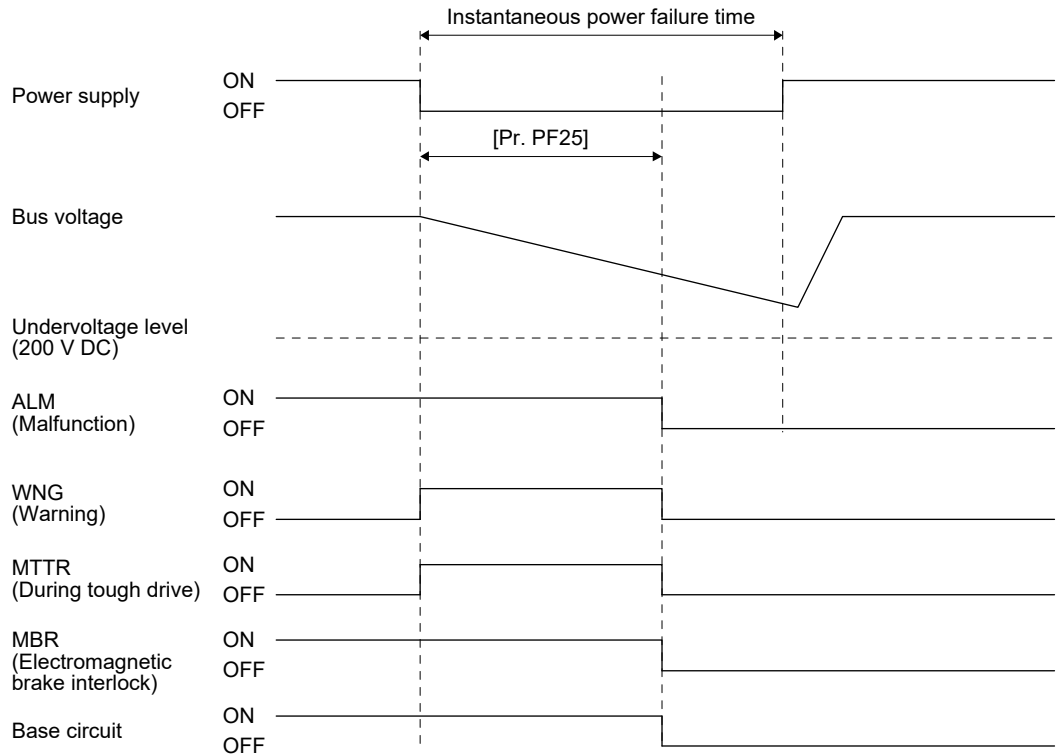

(b) When the bus voltage does not decrease to 200 V DC or lower within the instantaneous power failure time

The operation continues without alarming.

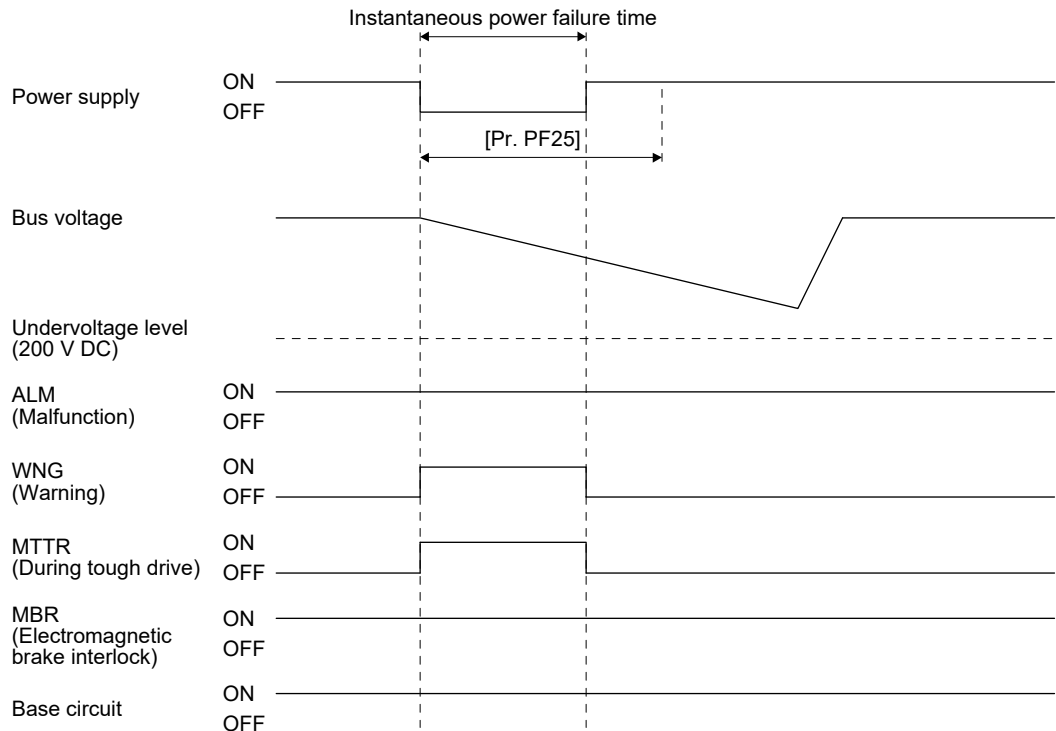

7. SPECIAL ADJUSTMENT FUNCTIONS

7.4 Model adaptive control disabled

POINT
<ul style="list-style-type: none"> ● Change the parameters while the servo motor stops. ● When setting auto tuning response ([Pr. PA09]), change the setting value one by one to adjust it while checking operation status of the servo motor.

(1) Summary

The servo amplifier has a model adaptive control. The servo amplifier has a virtual motor model and drives the servo motor following the output of the motor model in the model adaptive control. At model adaptive control disabled, the servo amplifier drives the motor with PID control without using the model adaptive control.

The following shows the available parameters at model adaptive control disabled.

Parameter	Symbol	Name
PB08	PG2	Position loop gain
PB09	VG2	Speed loop gain
PB10	VIC	Speed integral compensation

(2) Parameter setting

Set [Pr. PB25] to " _ _ _ 2".

(3) Restrictions

The following functions are not available at model adaptive control disabled.

Function	Explanation
Forced stop deceleration function ([Pr. PA04])	Disabling the model adaptive control while the forced stop deceleration function is enabled, [AL. 37] will occur. The forced stop deceleration function is enabled at factory setting. Set [Pr. PA04] to "0 _ _ _" (Forced stop deceleration function disabled).
Vibration suppression control 1 ([Pr. PB02]/[Pr. PB19]/[Pr. PB20]) Vibration suppression control 2 ([Pr. PB02]/[Pr. PB52]/[Pr. PB53])	The vibration suppression control uses the model adaptive control. Disabling the model adaptive control will also disable the vibration suppression control.
Overshoot amount compensation ([Pr. PB12])	The overshoot amount compensation uses data used by the model adaptive control. Disabling the model adaptive control will also disable the overshoot amount compensation.

7. SPECIAL ADJUSTMENT FUNCTIONS

7.5 Lost motion compensation function

POINT
<ul style="list-style-type: none"> ● The lost motion compensation function is enabled only in the position control mode.

The lost motion compensation function corrects response delays (caused by a non-sensitive band due to friction, twist, expansion, and backlash) caused when the machine travel direction is reversed. This function contributes to improvement for protrusions that occur at a quadrant change and streaks that occur at a quadrant change during circular cutting.

This function is effective when a high follow-up performance is required such as drawing an arc with an X-Y table.

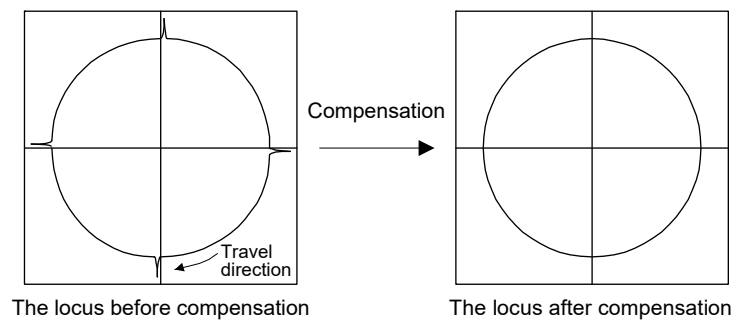

(1) Parameter setting

Setting [Pr. PE44] to [Pr. PE50] enables the lost motion compensation function.

(a) Lost motion compensation function selection ([Pr. PE48])

Select the lost motion compensation function.

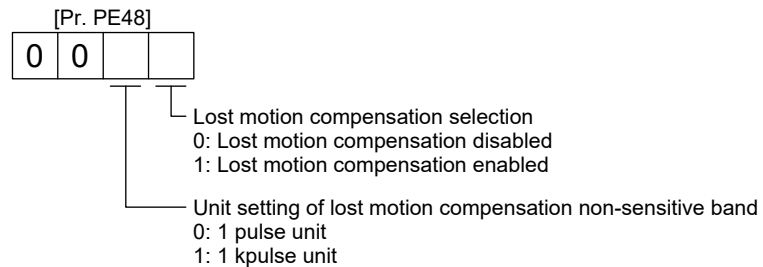

(b) Lost motion compensation ([Pr. PE44]/[Pr. PE45])

Set the same value for the lost motion compensation for each of when the forward rotation switches to the reverse rotation and when the reverse rotation switches to the forward rotation. When the heights of protrusions differ depending on the travel direction, set the different compensation for each travel direction. Set a value twice the usual friction torque and adjust the value while checking protrusions.

(c) Torque offset ([Pr. PE47])

For a vertical axis, unbalanced torque occurs due to the gravity. Although setting the torque offset is usually unnecessary, setting unbalanced torque of a machine as a torque offset cancels the unbalanced torque. The torque offset does not need to be set for a machine not generating unbalanced torque.

7. SPECIAL ADJUSTMENT FUNCTIONS

(d) Lost motion compensation timing ([Pr. PE49])

You can set the delay time of the lost motion compensation start timing with this parameter. When a protrusion occurs belatedly, set the lost motion compensation timing corresponding to the protrusion occurrence timing.

(e) Lost motion compensation non-sensitive band ([Pr. PE50])

When the travel direction reverses frequently around the zero speed, unnecessary lost motion compensation is triggered by the travel direction switching. By setting the lost motion compensation non-sensitive band, the speed is recognized as 0 when the fluctuation of the droop pulses is the setting value or less. This prevents unnecessary lost motion compensation.

When the value of this parameter is changed, the compensation timing is changed. Adjust the value of Lost motion compensation timing ([Pr. PE49]).

(f) Lost motion filter setting ([Pr. PE46])

Changing the value of this parameter is usually unnecessary. When a value other than 0.0 ms is set in this parameter, the high-pass filter output value of the set time constant is applied to the compensation and lost motion compensation continues.

(2) Adjustment procedure of the lost motion compensation function

(a) Measuring the load current

Measure the load currents during the forward direction feed and reverse direction feed with MR Configurator2.

(b) Setting the lost motion compensation

Calculate the friction torque from the measurement result of (a) in this section and set a value twice the friction torque in [Pr. PE44] and [Pr. PE45] as lost motion compensation.

$$\text{Friction torque [\%]} = \frac{|\text{(load current during feed in the forward rotation direction [\%])} - \text{(load current during feed in the reverse rotation direction [\%])}|}{2}$$

(c) Checking protrusions

Drive the servo motor and check that the protrusions are corrected.

7. SPECIAL ADJUSTMENT FUNCTIONS

(d) Adjusting the lost motion compensation

When protrusions still occur, the compensation is insufficient. Increase the lost motion compensation by approximately 0.5% until the protrusions are eliminated. When notches occur, the compensation is excessive. Decrease the lost motion compensation by approximately 0.5% until the notches are eliminated. Different values can be set as the compensation for each of when the forward rotation (CCW) switches to the reverse rotation (CW) and when the reverse rotation (CW) switches to the forward rotation (CCW).

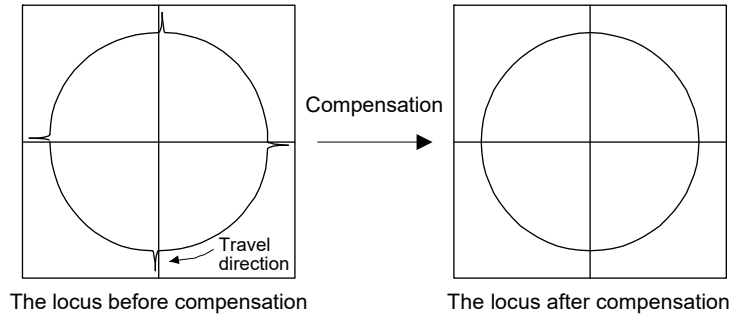

(e) Adjusting the lost motion compensation timing

When the machine has low rigidity, the speed loop gain is set lower than the standard setting value, or the servo motor is rotating at high speed, quadrant projections may occur behind the quadrant change points. In this case, you can suppress the quadrant projections by delaying the lost motion compensation timing with [Pr. PE49 Lost motion compensation timing]. Increase the setting value of [Pr. PE49] from 0 ms (initial value) by approximately 0.5 ms to adjust the compensation timing.

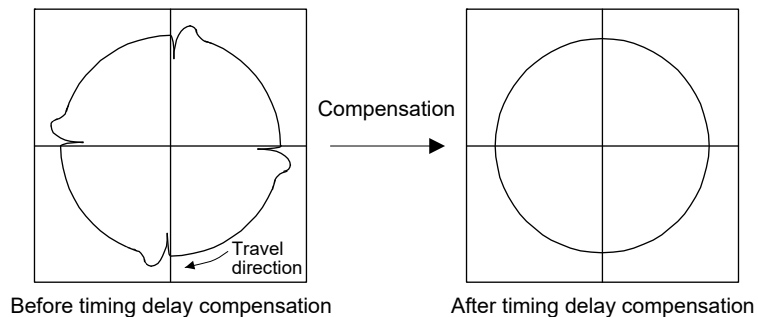

(f) Adjusting the lost motion compensation non-sensitive band

When the lost motion is compensated twice around a quadrant change point, set [Pr. PE50 Lost motion compensation non-sensitive band]. Increase the setting value so that the lost motion is not compensated twice. Setting [Pr. PE50] may changes the compensation timing. Adjust the lost motion compensation timing of (2) (e) in this section.

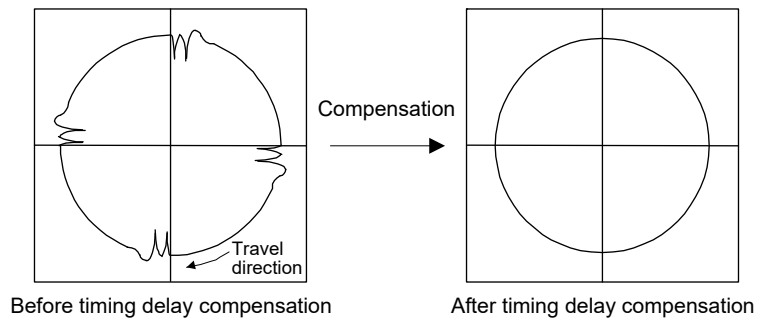

8. TROUBLESHOOTING

8. TROUBLESHOOTING

POINT	
	<ul style="list-style-type: none"> ● Refer to "MELSERVO-JE Servo Amplifier Instruction Manual (Troubleshooting)" for details of alarms and warnings. ● As soon as an alarm occurs, make the Servo-off status and interrupt the power. ● [AL. 37 Parameter error] and warnings (except [AL. F0 Tough drive warning]) are not recorded in the alarm history.

When an error occurs during operation, the corresponding alarm or warning is displayed. When an alarm or warning is displayed, refer to "MELSERVO-JE Servo Amplifier Instruction Manual (Troubleshooting)" to remove the failure. When an alarm occurs, ALM (Malfunction) will turn off.

8.1 Explanation for the lists

(1) No./Name/Detail number/Detail name

Indicates the number, name, detail number, detail name of alarms or warnings.

(2) Stop method

For the alarms and warnings in which "SD" is written in the stop method column, the servo motor stops with the dynamic brake after forced stop deceleration. For the alarms and warnings written "DB" or "EDB" in the stop method column, the servo motor stops with the dynamic brake without forced stop deceleration.

(3) Alarm deactivation

After the cause of the alarm has been removed, the alarm can be deactivated by any of the methods marked E in the alarm deactivation column. Warnings are automatically canceled after the cause of occurrence is removed. Alarms are deactivated with alarm reset, CPU reset, or power cycling.

Alarm deactivation	Explanation
Alarm reset	1. Error reset command from the controller 2. Push "Occurring Alarm Reset" in the "Alarm Display" window of MR Configurator2.
CPU reset	Reset the controller itself.
Power cycling	Turn off the power, check that the 3-digit, 7-segment LED display is off, and then turn on the power.

8. TROUBLESHOOTING

8.2 Alarm list

	No.	Name	Detail No.	Detail name	Stop method (Note 2, 3)	Alarm deactivation		
						Alarm reset	CPU reset	Power cycling
Alarm	10	Undervoltage	10.1	Voltage drop in the power	EDB	○	○	○
			10.2	Bus voltage drop	SD	○	○	○
	12	Memory error 1 (RAM)	12.1	RAM error 1	DB	/	/	○
			12.2	RAM error 2	DB	/	/	○
			12.3	RAM error 3	DB	/	/	○
			12.4	RAM error 4	DB	/	/	○
			12.5	RAM error 5	DB	/	/	○
			12.6	RAM error 6	DB	/	/	○
	13	Clock error	13.1	Clock error 1	DB	/	/	○
			13.2	Clock error 2	DB	/	/	○
			13.3	Clock error 3	DB	/	/	○
	14	Control process error	14.1	Control process error 1	DB	/	/	○
			14.2	Control process error 2	DB	/	/	○
			14.3	Control process error 3	DB	/	/	○
			14.4	Control process error 4	DB	/	/	○
			14.5	Control process error 5	DB	/	/	○
			14.6	Control process error 6	DB	/	/	○
			14.7	Control process error 7	DB	/	/	○
			14.8	Control process error 8	DB	/	/	○
			14.9	Control process error 9	DB	/	/	○
			14.A	Control process error 10	DB	/	/	○
			14.C	Control process error 12	DB	/	/	○
			14.D	Control process error 13	DB	/	/	○
			15	Memory error 2 (EEP-ROM)	15.1	EEP-ROM error at power on	DB	/
	15.2	EEP-ROM error during operation			DB	/	/	○
	15.4	Home position information read error			DB	/	/	○
	16	Encoder initial communication error 1	16.1	Encoder initial communication - Receive data error 1	DB	/	/	○
			16.2	Encoder initial communication - Receive data error 2	DB	/	/	○
			16.3	Encoder initial communication - Receive data error 3	DB	/	/	○
			16.5	Encoder initial communication - Transmission data error 1	DB	/	/	○
			16.6	Encoder initial communication - Transmission data error 2	DB	/	/	○
			16.7	Encoder initial communication - Transmission data error 3	DB	/	/	○
			16.A	Encoder initial communication - Process error 1	DB	/	/	○
			16.B	Encoder initial communication - Process error 2	DB	/	/	○
			16.C	Encoder initial communication - Process error 3	DB	/	/	○
			16.D	Encoder initial communication - Process error 4	DB	/	/	○
			16.E	Encoder initial communication - Process error 5	DB	/	/	○
			16.F	Encoder initial communication - Process error 6	DB	/	/	○
			17	Board error	17.1	Board error 1	DB	/
	17.3	Board error 2			DB	/	/	○
	17.4	Board error 3			DB	/	/	○
	17.5	Board error 4			DB	/	/	○
17.6	Board error 5	DB			/	/	○	
17.7	Board error 7	DB			/	/	○	

8. TROUBLESHOOTING

	No.	Name	Detail No.	Detail name	Stop method (Note 2, 3)	Alarm deactivation		
						Alarm reset	CPU reset	Power cycling
Alarm	19	Memory error 3 (Flash-ROM)	19.1	Flash-ROM error 1	DB	<input type="checkbox"/>	<input type="checkbox"/>	<input type="checkbox"/>
			19.2	Flash-ROM error 2	DB	<input type="checkbox"/>	<input type="checkbox"/>	<input type="checkbox"/>
			19.4	Flash-ROM error 4	DB	<input type="checkbox"/>	<input type="checkbox"/>	<input type="checkbox"/>
			19.5	Flash-ROM error 5	DB	<input type="checkbox"/>	<input type="checkbox"/>	<input type="checkbox"/>
			1A	Servo motor combination error	1A.1	Servo motor combination error 1	DB	<input type="checkbox"/>
	1A.4	Servo motor combination error 2	DB		<input type="checkbox"/>	<input type="checkbox"/>	<input type="checkbox"/>	
	1E	Encoder initial communication error 2	1E.1	Encoder malfunction	DB	<input type="checkbox"/>	<input type="checkbox"/>	<input type="checkbox"/>
	1F	Encoder initial communication error 3	1F.1	Incompatible encoder	DB	<input type="checkbox"/>	<input type="checkbox"/>	<input type="checkbox"/>
	20	Encoder normal communication error 1	20.1	Encoder normal communication - Receive data error 1	EDB	<input type="checkbox"/>	<input type="checkbox"/>	<input type="checkbox"/>
			20.2	Encoder normal communication - Receive data error 2	EDB	<input type="checkbox"/>	<input type="checkbox"/>	<input type="checkbox"/>
			20.3	Encoder normal communication - Receive data error 3	EDB	<input type="checkbox"/>	<input type="checkbox"/>	<input type="checkbox"/>
			20.5	Encoder normal communication - Transmission data error 1	EDB	<input type="checkbox"/>	<input type="checkbox"/>	<input type="checkbox"/>
			20.6	Encoder normal communication - Transmission data error 2	EDB	<input type="checkbox"/>	<input type="checkbox"/>	<input type="checkbox"/>
			20.7	Encoder normal communication - Transmission data error 3	EDB	<input type="checkbox"/>	<input type="checkbox"/>	<input type="checkbox"/>
			20.9	Encoder normal communication - Receive data error 4	EDB	<input type="checkbox"/>	<input type="checkbox"/>	<input type="checkbox"/>
			20.A	Encoder normal communication - Receive data error 5	EDB	<input type="checkbox"/>	<input type="checkbox"/>	<input type="checkbox"/>
	21	Encoder normal communication error 2	21.1	Encoder data error 1	EDB	<input type="checkbox"/>	<input type="checkbox"/>	<input type="checkbox"/>
			21.2	Encoder data update error	EDB	<input type="checkbox"/>	<input type="checkbox"/>	<input type="checkbox"/>
			21.3	Encoder data waveform error	EDB	<input type="checkbox"/>	<input type="checkbox"/>	<input type="checkbox"/>
			21.5	Encoder hardware error 1	EDB	<input type="checkbox"/>	<input type="checkbox"/>	<input type="checkbox"/>
			21.6	Encoder hardware error 2	EDB	<input type="checkbox"/>	<input type="checkbox"/>	<input type="checkbox"/>
			21.9	Encoder data error 2	EDB	<input type="checkbox"/>	<input type="checkbox"/>	<input type="checkbox"/>
	24	Main circuit error	24.1	Ground fault detected at hardware detection circuit	DB	<input type="checkbox"/>	<input type="checkbox"/>	<input type="checkbox"/>
			24.2	Ground fault detected at software detection function	DB	<input type="checkbox"/>	<input type="checkbox"/>	<input type="checkbox"/>
	25	Absolute position erased	25.1	Servo motor encoder - Absolute position erased	DB	<input type="checkbox"/>	<input type="checkbox"/>	<input type="checkbox"/>
	30	Regenerative error	30.1	Regeneration heat error	DB	<input type="checkbox"/> (Note 1)	<input type="checkbox"/> (Note 1)	<input type="checkbox"/> (Note 1)
			30.2	Regeneration signal error	DB	<input type="checkbox"/> (Note 1)	<input type="checkbox"/> (Note 1)	<input type="checkbox"/> (Note 1)
			30.3	Regeneration feedback signal error	DB	<input type="checkbox"/> (Note 1)	<input type="checkbox"/> (Note 1)	<input type="checkbox"/> (Note 1)
	31	Overspeed	31.1	Abnormal motor speed	SD	<input type="checkbox"/>	<input type="checkbox"/>	<input type="checkbox"/>
	32	Overcurrent	32.1	Overcurrent detected at hardware detection circuit (during operation)	DB	<input type="checkbox"/>	<input type="checkbox"/>	<input type="checkbox"/>
			32.2	Overcurrent detected at software detection function (during operation)	DB	<input type="checkbox"/>	<input type="checkbox"/>	<input type="checkbox"/>
			32.3	Overcurrent detected at hardware detection circuit (during a stop)	DB	<input type="checkbox"/>	<input type="checkbox"/>	<input type="checkbox"/>
			32.4	Overcurrent detected at software detection function (during a stop)	DB	<input type="checkbox"/>	<input type="checkbox"/>	<input type="checkbox"/>
	33	Overvoltage	33.1	Main circuit voltage error	EDB	<input type="checkbox"/>	<input type="checkbox"/>	<input type="checkbox"/>
	34	SSCNET receive error 1	34.1	SSCNET receive data error	SD	<input type="checkbox"/>	<input type="checkbox"/> (Note 4)	<input type="checkbox"/>
34.2			SSCNET connector connection error	SD	<input type="checkbox"/>	<input type="checkbox"/>	<input type="checkbox"/>	
34.3			SSCNET communication data error	SD	<input type="checkbox"/>	<input type="checkbox"/>	<input type="checkbox"/>	
34.4			Hardware error signal detection	SD	<input type="checkbox"/>	<input type="checkbox"/>	<input type="checkbox"/>	
35	Command frequency error	35.1	Command frequency error	SD	<input type="checkbox"/>	<input type="checkbox"/>	<input type="checkbox"/>	

8. TROUBLESHOOTING

	No.	Name	Detail No.	Detail name	Stop method (Note 2, 3)	Alarm deactivation		
						Alarm reset	CPU reset	Power cycling
Alarm	36	SSCNET receive error 2	36.1	Continuous communication data error	SD	○	○	○
	37	Parameter error	37.1	Parameter setting range error	DB	△	○	○
			37.2	Parameter combination error	DB	△	○	○
			37.3	Point table setting error	DB	△	○	○
	39	Program error	39.1	Program error	DB	△	○	○
			39.2	Instruction argument external error	DB	△	○	○
			39.3	Register No. error	DB	△	○	○
			39.4	Non-correspondence command error	DB	△	○	○
	3A	Inrush current suppression circuit error	3A.1	Inrush current suppression circuit error	EDB	△	○	○
	3E	Operation mode error	3E.1	Operation mode error	DB	△	○	○
			3E.6	Operation mode switch error	DB	△	○	○
	45	Main circuit device overheat	45.1	Main circuit device overheat error 1	SD	○ (Note 1)	○ (Note 1)	○ (Note 1)
	46	Servo motor overheat	46.1	Abnormal temperature of servo motor 1	SD	○ (Note 1)	○ (Note 1)	○ (Note 1)
			46.5	Abnormal temperature of servo motor 3	DB	○ (Note 1)	○ (Note 1)	○ (Note 1)
			46.6	Abnormal temperature of servo motor 4	DB	○ (Note 1)	○ (Note 1)	○ (Note 1)
	47	Cooling fan error	47.2	Cooling fan speed reduction error	SD	△	○	○
	50	Overload 1	50.1	Thermal overload error 1 during operation	SD	○ (Note 1)	○ (Note 1)	○ (Note 1)
			50.2	Thermal overload error 2 during operation	SD	○ (Note 1)	○ (Note 1)	○ (Note 1)
			50.3	Thermal overload error 4 during operation	SD	○ (Note 1)	○ (Note 1)	○ (Note 1)
			50.4	Thermal overload error 1 during a stop	SD	○ (Note 1)	○ (Note 1)	○ (Note 1)
			50.5	Thermal overload error 2 during a stop	SD	○ (Note 1)	○ (Note 1)	○ (Note 1)
			50.6	Thermal overload error 4 during a stop	SD	○ (Note 1)	○ (Note 1)	○ (Note 1)
	51	Overload 2	51.1	Thermal overload error 3 during operation	DB	○ (Note 1)	○ (Note 1)	○ (Note 1)
			51.2	Thermal overload error 3 during a stop	DB	○ (Note 1)	○ (Note 1)	○ (Note 1)
	52	Error excessive	52.1	Excess droop pulse 1	SD	○	○	○
			52.3	Excess droop pulse 2	SD	○	○	○
			52.4	Error excessive during 0 torque limit	SD	○	○	○
			52.5	Excess droop pulse 3	EDB	○	○	○
	54	Oscillation detection	54.1	Oscillation detection error	EDB	○	○	○
	56	Forced stop error	56.2	Over speed during forced stop	EDB	○	○	○
			56.3	Estimated distance over during forced stop	EDB	○	○	○
	61	Operation error	61.1	Point table setting range error	DB	○	△	○
	69	Command error	69.1	Forward rotation-side software limit detection - Command excess error	SD	○	○	○
			69.2	Reverse rotation-side software limit detection - Command excess error	SD	○	○	○
			69.3	Forward rotation stroke end detection - Command excess error	SD	○	○	○
			69.4	Reverse rotation stroke end detection - Command excess error	SD	○	○	○
	86	Network communication error	86.1	Network communication error 1	SD	○	△	○
			86.4	Network communication error 4	SD	○	△	○
			86.5	Network communication error 5	SD	○	△	○

8. TROUBLESHOOTING

	No.	Name	Detail No.	Detail name	Stop method (Note 2, 3)	Alarm deactivation		
						Alarm reset	CPU reset	Power cycling
Alarm	8A	USB communication time-out error/serial communication time-out error/Modbus RTU communication time-out error	8A.1	USB communication time-out error/serial communication time-out error	SD	○	○	○
			8A.2	Modbus RTU communication time-out error	SD	○	○	○
	8C	Network module communication error	8C.1	Network module communication error 1	SD	△	△	○
			8C.2	Network module communication error 2	SD	△	△	○
			8C.3	Network module communication error 3	SD	△	△	○
			8C.4	Network module communication error 4	SD	△	△	○
			8C.5	Network module communication error 5	SD	△	△	○
			8C.6	Network module communication error 6	SD	△	△	○
			8C.7	Network module communication error 7	SD	△	△	○
	8E	USB communication error/serial communication error/Modbus RTU communication error	8E.1	USB communication receive error/serial communication receive error	SD	○	○	○
			8E.2	USB communication checksum error/serial communication checksum error	SD	○	○	○
			8E.3	USB communication character error/serial communication character error	SD	○	○	○
			8E.4	USB communication command error/serial communication command error	SD	○	○	○
			8E.5	USB communication data number error/serial communication data number error	SD	○	○	○
			8E.6	Modbus RTU communication receive error	SD	○	○	○
			8E.7	Modbus RTU communication message frame error	SD	○	○	○
			8E.8	Modbus RTU communication CRC error	SD	○	○	○
	888/88888	Watchdog	88_/_/8888_	Watchdog	DB	△	△	○

- Note 1. After resolving the source of trouble, cool the equipment for approximately 30 minutes.
2. The following shows three stop methods of DB, EDB, and SD.
 DB: Dynamic brake stop (For a servo amplifier without the dynamic brake, the servo motor coasts.)
 EDB: Electronic dynamic brake stop (available with specified servo motors)
 Refer to the following table for the specified servo motors. The stop method for other than the specified servo motors is DB.
 For MR-JE_A, setting [Pr. PF09] to "(_ _ 3)" enables the electronic dynamic brake.

Series	Servo motor
HG-KN	HG-KN053/HG-KN13/HG-KN23/HG-KN43
HG-SN	HG-SN52

SD: Forced stop deceleration

3. This is applicable when [Pr. PA04] is set to the initial value. The stop method of SD can be changed to DB using [Pr. PA04].
4. In some controller communication status, the alarm factor may not be removed.

8. TROUBLESHOOTING

8.3 Warning list

No.	Name	Detail No.	Detail name	Stop method (Note 2, 3)	
Warning	90	Home position return incomplete warning	90.1	Home position return incomplete	
			90.2	Home position return abnormal termination	
			90.5	Z-phase unpassed	
	91	Servo amplifier overheat warning (Note 1)	91.1	Main circuit device overheat warning	
	92	Battery cable disconnection warning	92.1	Encoder battery cable disconnection warning	
			92.3	Battery degradation	
	96	Home position setting warning	96.1	In-position warning at home positioning	
			96.2	Command input warning at home positioning	
			96.3	Servo off warning at home positioning	
	97	Positioning specification warning	97.1	Program operation disabled warning	
	98	Software limit warning	98.1	Forward rotation-side software stroke limit reached	
			98.2	Reverse rotation-side software stroke limit reached	
	99	Stroke limit warning	99.1	Forward rotation stroke end off	(Note 4)
			99.2	Reverse rotation stroke end off	(Note 4)
	9B	Error excessive warning	9B.1	Excess droop pulse 1 warning	
			9B.3	Excess droop pulse 2 warning	
			9B.4	Error excessive warning during 0 torque limit	
	9F	Battery warning	9F.1	Low battery	
	E0	Excessive regeneration warning	E0.1	Excessive regeneration warning	
	E1	Overload warning 1	E1.1	Thermal overload warning 1 during operation	
			E1.2	Thermal overload warning 2 during operation	
E1.3			Thermal overload warning 3 during operation		
E1.4			Thermal overload warning 4 during operation		
E1.5			Thermal overload warning 1 during a stop		
E1.6			Thermal overload warning 2 during a stop		
E1.7			Thermal overload warning 3 during a stop		
E1.8			Thermal overload warning 4 during a stop		
E3	Absolute position counter warning	E3.1	Multi-revolution counter travel distance excess warning		
		E3.2	Absolute position counter warning		
		E3.4	Absolute positioning counter EEPROM writing frequency warning		
		E3.5	Encoder absolute positioning counter warning		
E4	Parameter warning	E4.1	Parameter setting range error warning		
E6	Servo forced stop warning	E6.1	Forced stop warning	SD	
E7	Controller forced stop warning	E7.1	Controller forced stop input warning	SD	
E8	Cooling fan speed reduction warning	E8.1	Decreased cooling fan speed warning		

8. TROUBLESHOOTING

	No.	Name	Detail No.	Detail name	Stop method (Note 2, 3)
Warning	E9	Main circuit off warning	E9.1	Servo-on signal on during main circuit off	DB
			E9.2	Bus voltage drop during low speed operation	DB
			E9.3	Ready-on signal on during main circuit off	DB
	EC	Overload warning 2	EC.1	Overload warning 2	
	ED	Output watt excess warning	ED.1	Output watt excess warning	
	F0	Tough drive warning	F0.1	Instantaneous power failure tough drive warning	
			F0.3	Vibration tough drive warning	
	F2	Drive recorder - Miswriting warning	F2.1	Drive recorder - Area writing time-out warning	
			F2.2	Drive recorder - Data miswriting warning	
	F3	Oscillation detection warning	F3.1	Oscillation detection warning	
	F4	Positioning warning	F4.4	Target position setting range error warning	
			F4.6	Acceleration time constant setting range error warning	
			F4.7	Deceleration time constant setting range error warning	
			F4.8	Control command input error warning	
	F5	Simple cam function - Cam data miswriting warning	F5.1	Cam data - Area writing time-out warning	
			F5.2	Cam data - Area miswriting warning	
			F5.3	Cam data checksum error	
	F6	Simple cam function - Cam control warning	F6.1	Cam axis one cycle current value restoration failed	
			F6.2	Cam axis feed current value restoration failed	
			F6.3	Cam unregistered error	
			F6.4	Cam control data setting range error	
F6.5			Cam No. external error		
F6.6			Cam control inactive		

- Note
1. After resolving the source of trouble, cool the equipment for approximately 30 minutes.
 2. The following shows two stop methods of DB and SD.
DB: Dynamic brake stop (For a servo amplifier without the dynamic brake, the servo motor coasts.)
SD: Forced stop deceleration
 3. This is applicable when [Pr. PA04] is set to the initial value. The stop method of SD can be changed to DB using [Pr. PA04].
 4. Quick stop or slow stop can be selected using [Pr. PD30] for the MR-JE-_A or using [Pr. PD35] for the MR-JE-_C (except in the profile mode).

9. DIMENSIONS

9. DIMENSIONS

9.1 Servo amplifier

(1) MR-JE-10B to MR-JE-40B

[Unit: mm]

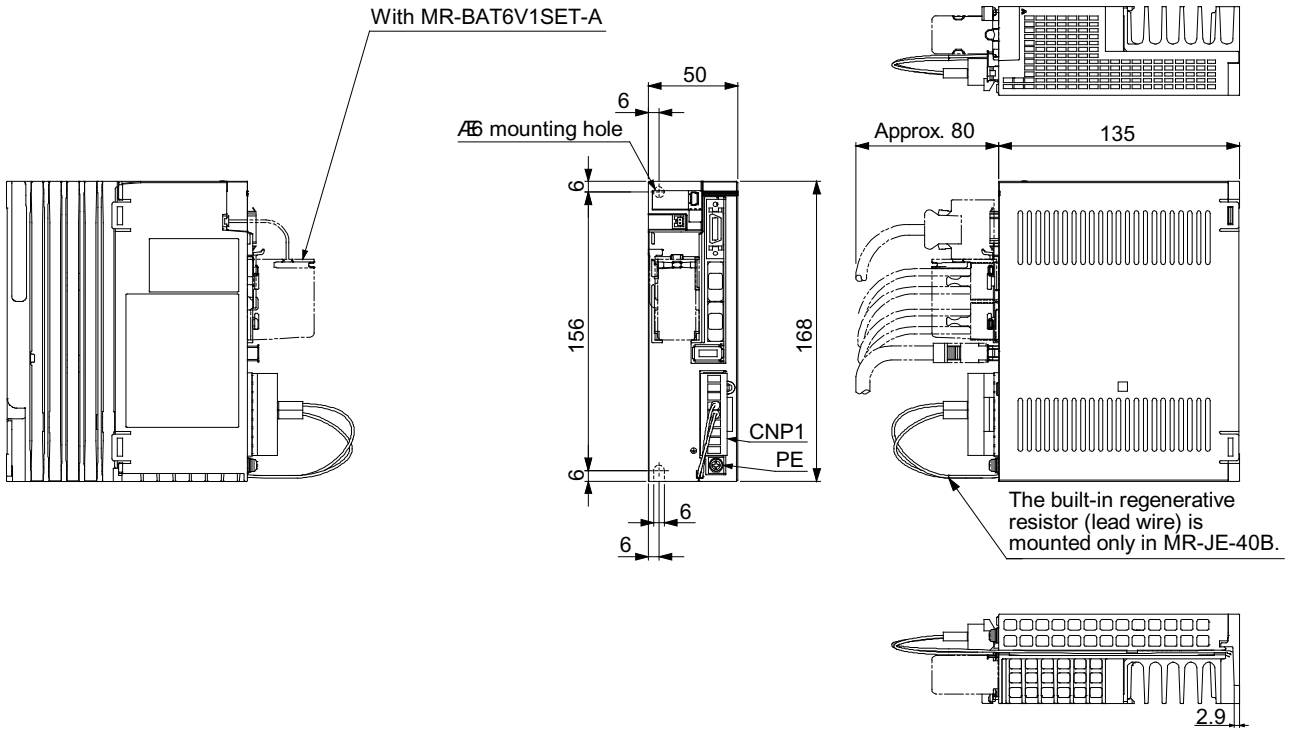

Mass: 0.8 [kg]

Mounting screw
Screw size: M5
Tightening torque: 3.24 [N•m]

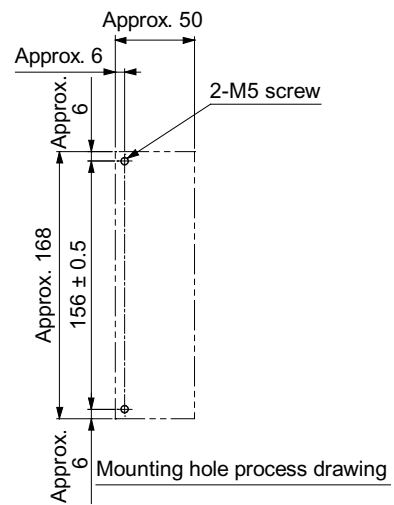
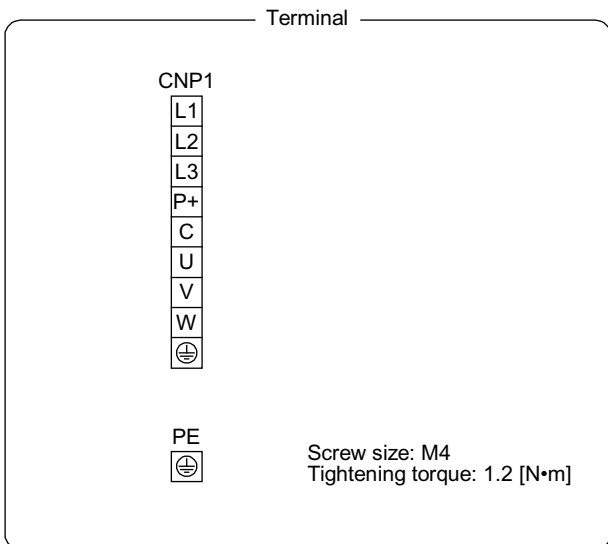

9. DIMENSIONS

(2) MR-JE-70B/MR-JE-100B

[Unit: mm]

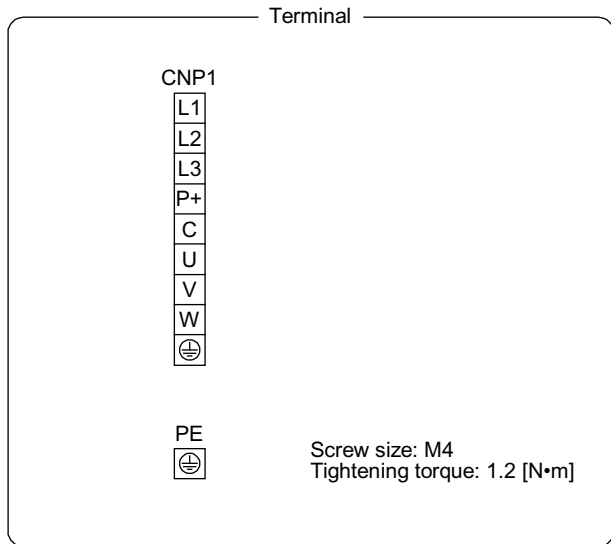
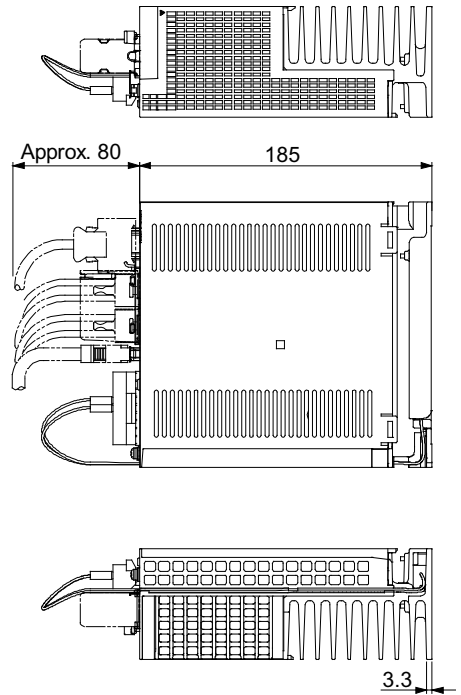
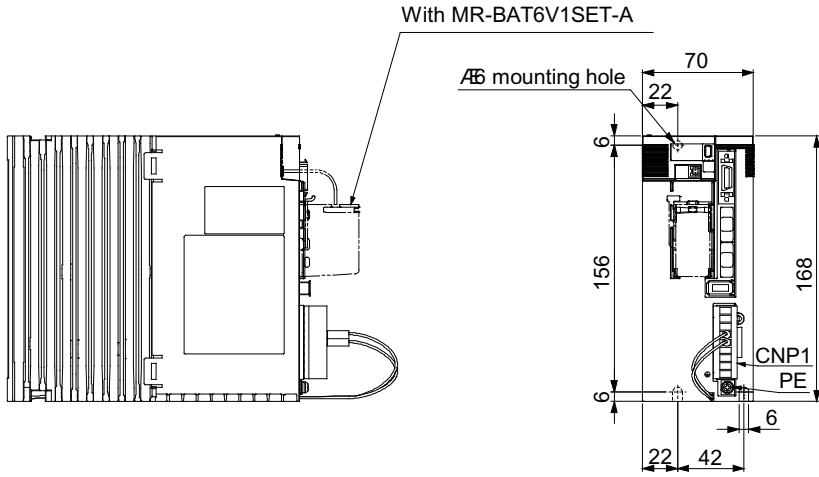

Mass: 1.5 [kg]
 Mounting screw
 Screw size: M5
 Tightening torque: 3.24 [N·m]

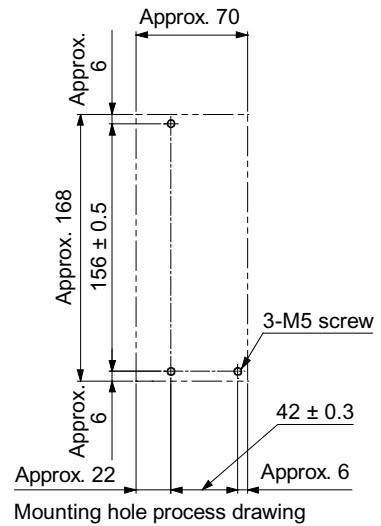

9. DIMENSIONS

(3) MR-JE-200B/MR-JE-300B

[Unit: mm]

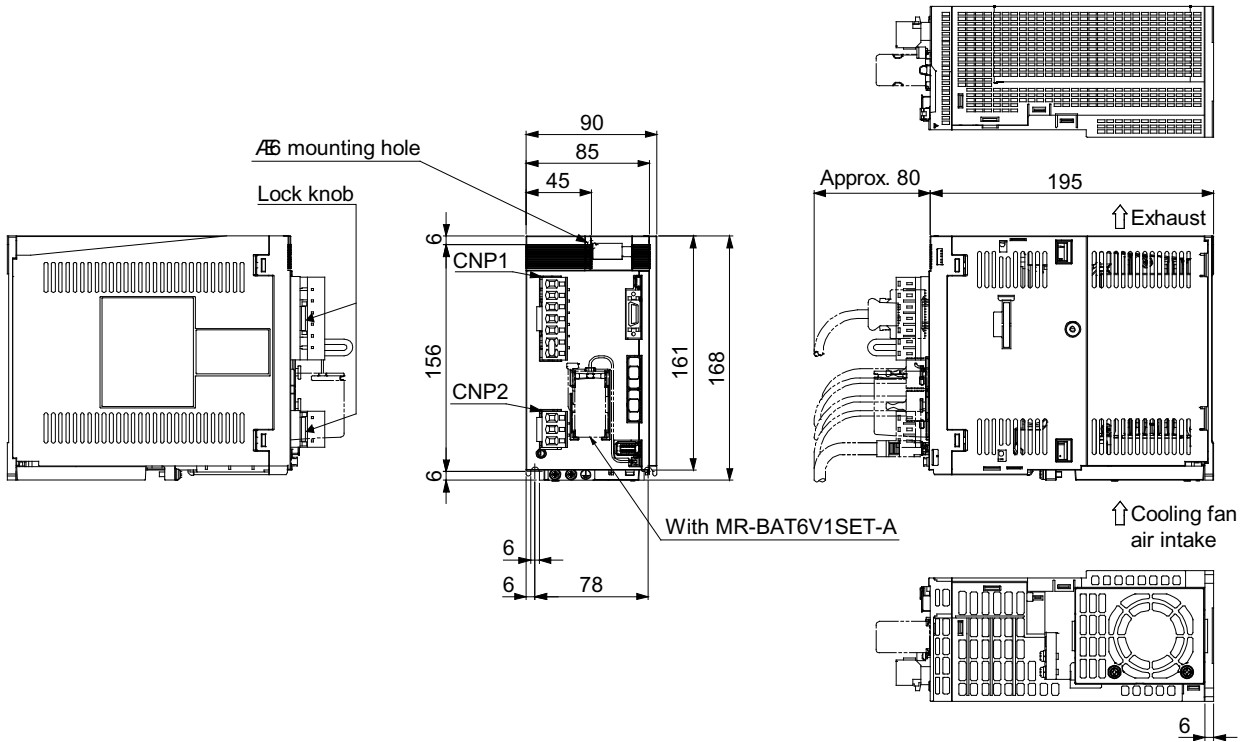

Mass: 2.1 [kg]

Mounting screw
Screw size: M5
Tightening torque: 3.24 [N•m]

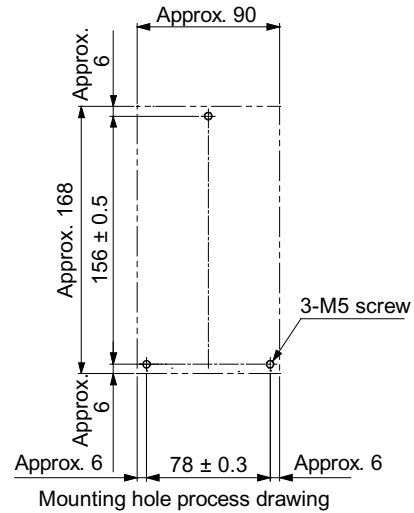
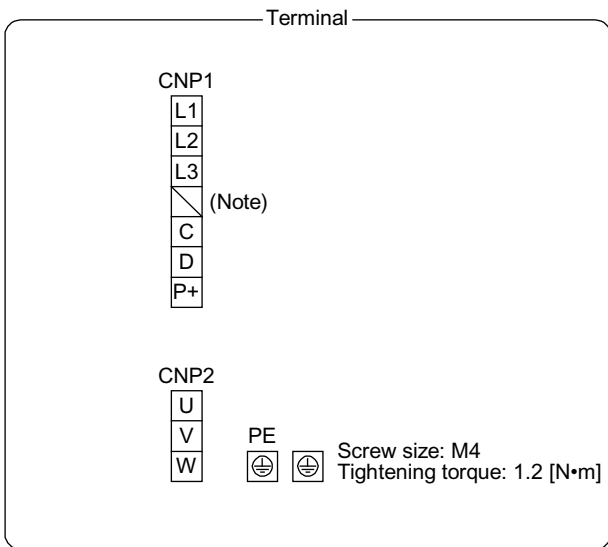

Note. The servo amplifiers without the N- terminal will be available sequentially from the December 2016 production.

9. DIMENSIONS

9.2 Connector

(1) CN1A/CN1B connector

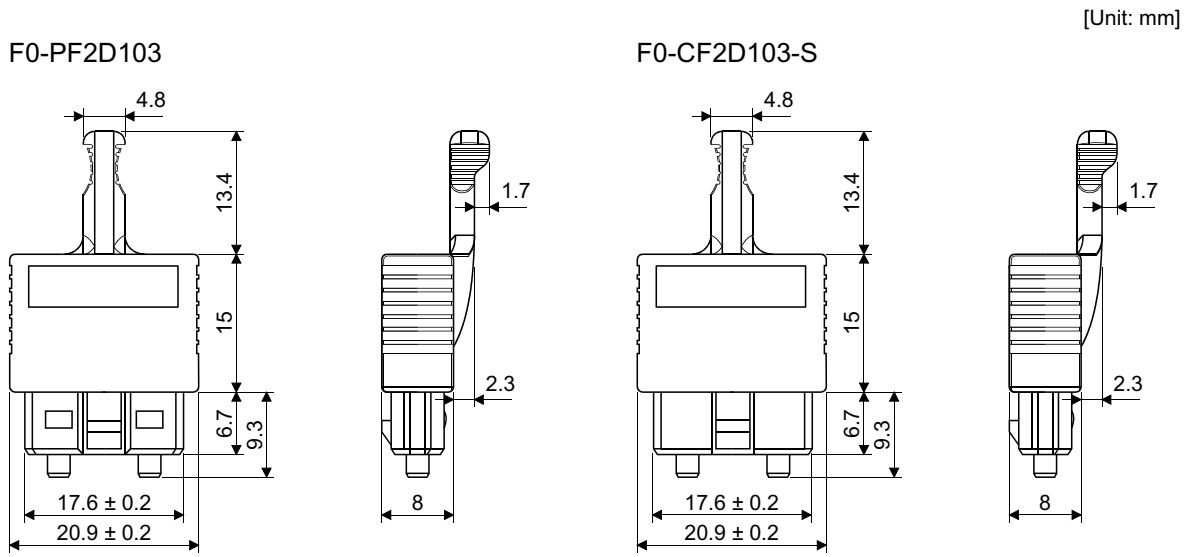

(2) SCR connector system (3M) Receptacle: 36210-0100PL Shell kit: 36310-3200-008

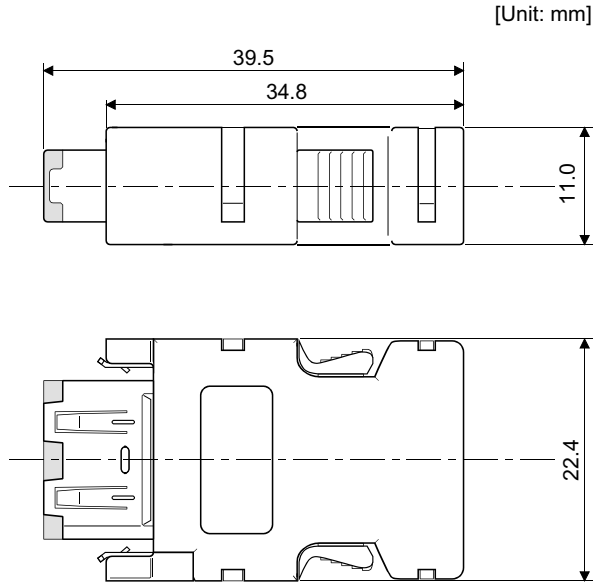

10. CHARACTERISTICS

10. CHARACTERISTICS

10.1 Overload protection characteristics

An electronic thermal is built in the servo amplifier to protect the servo motor, servo amplifier and servo motor power wires from overloads.

[AL. 50 Overload 1] occurs if overload operation performed is above the electronic thermal protection curve shown in fig. 10.1. [AL. 51 Overload 2] occurs if the maximum current is applied continuously for several seconds due to machine collision, etc. Use the equipment on the left-side area of the continuous or broken line in the graph.

For the system where the unbalanced torque occurs, such as a vertical axis system, the unbalanced torque of the machine should be kept at 70% or lower of the motor's rated torque.

This servo amplifier has a servo motor overload protection. (The servo motor overload current (full load current) is set on the basis of 110% rated current of the servo amplifier.)

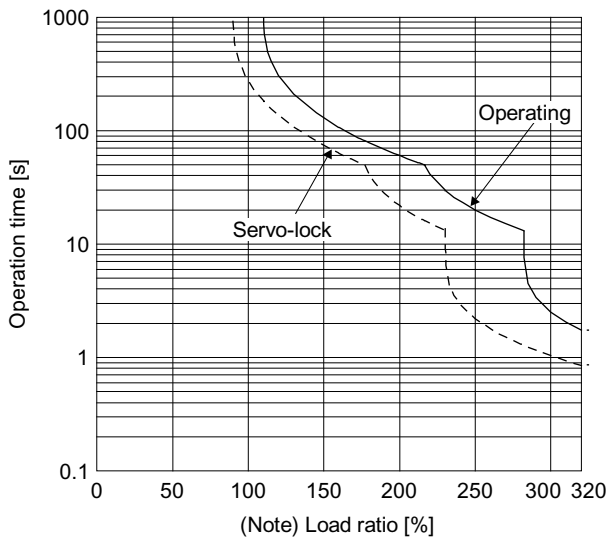

HG-KN13_

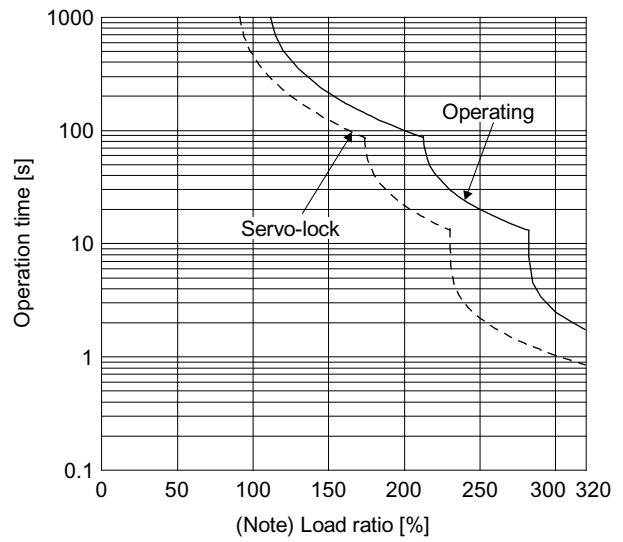

HG-KN23_/HG-KN43_/
HG-KN73_/HG-SN52_/
HG-SN102_

10. CHARACTERISTICS

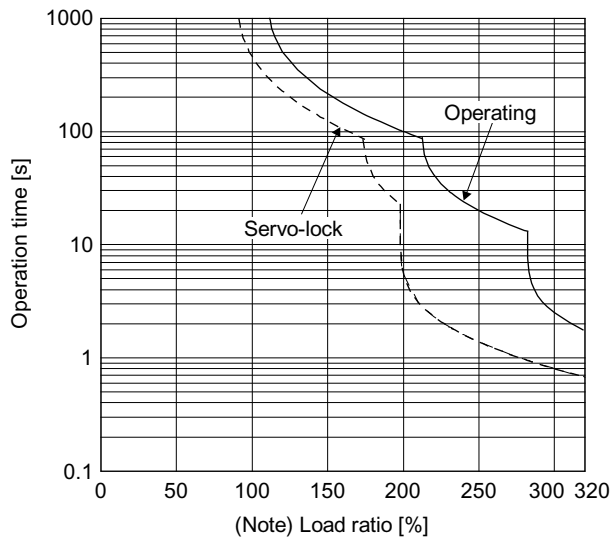

HG-SN152_/HG-SN202_/

HG-SN302_

Note. If operation that generates torque more than 100% of the rating is performed with an abnormally high frequency in a servo motor stop status (servo-lock status) or in a 50 r/min or lower low-speed operation status, the servo amplifier may malfunction regardless of the electronic thermal protection.

Fig. 10.1 Electronic thermal protection characteristics

10. CHARACTERISTICS

10.2 Power supply capacity and generated loss

(1) Servo amplifier generated heat

Table 10.1 indicates servo amplifiers' power supply capacities and losses generated under rated load. For thermal design of an enclosed type cabinet, use the values in the tables in consideration for the worst operating conditions including environments and operation patterns. The actual amount of generated heat will be intermediate between values at rated torque and servo-off according to the duty used during operation. When the servo motor is run at less than the rated speed, the power supply capacity will be smaller than the value in the table, but the servo amplifier's generated heat will not change.

Table 10.1 Power supply capacity and generated loss per servo motor at rated output

Servo amplifier	Servo motor	(Note 1) Power supply capacity [kVA]	(Note 2) Servo amplifier- generated heat [W]		Area required for heat dissipation [m ²]
			At rated output	With servo-off	
MR-JE-10B	HG-KN13_	0.3	25	15	0.5
MR-JE-20B	HG-KN23_	0.5	25	15	0.5
MR-JE-40B	HG-KN43_	0.9	35	15	0.7
MR-JE-70B	HG-KN73_	1.3	50	15	1.0
	HG-SN52_	1.0	40	15	0.8
MR-JE-100B	HG-SN102_	1.7	50	15	1.0
MR-JE-200B	HG-SN152_	2.5	90	20	1.8
	HG-SN202_	3.5			
MR-JE-300B	HG-SN302_	4.8	120	20	2.4

- Note 1. The power supply equipment capacity changes with the power supply impedance. This value is applicable when the power factor improving AC reactor is not used.
- Note 2. Heat generated during regeneration is not included in the servo amplifier-generated heat. To calculate heat generated by the regenerative option, refer to section 11.2.

10. CHARACTERISTICS

(2) Heat dissipation area for an enclosed type cabinet

The enclosed type cabinet (hereafter called the cabinet) which will contain the servo amplifier should be designed to ensure that its temperature rise is within +10 °C at the ambient temperature of 40 °C. (With an approximately 5 °C safety margin, the system should operate within a maximum 55 °C limit.) The necessary cabinet heat dissipation area can be calculated by equation 10.1.

$$A = \frac{P}{K \cdot \Delta T} \dots\dots\dots (10.1)$$

- A : Heat dissipation area [m²]
- P : Loss generated in the cabinet [W]
- T : Difference between internal and ambient temperatures [°C]
- K : Heat dissipation coefficient [5 to 6]

When calculating the heat dissipation area with equation 10.1, assume that P is the sum of all losses generated in the cabinet. Refer to table 10.1 for heat generated by the servo amplifier. "A" indicates the effective area for heat dissipation, but if the cabinet is directly installed on an insulated wall, that extra amount must be added to the cabinet's surface area. The required heat dissipation area will vary with the conditions in the cabinet. If convection in the cabinet is poor and heat builds up, effective heat dissipation will not be possible. Therefore, arrangement of the equipment in the cabinet and the use of a cooling fan should be considered. Table 10.1 lists the cabinet dissipation area for each servo amplifier (guideline) when the servo amplifier is operated at the ambient temperature of 40 °C under rated load.

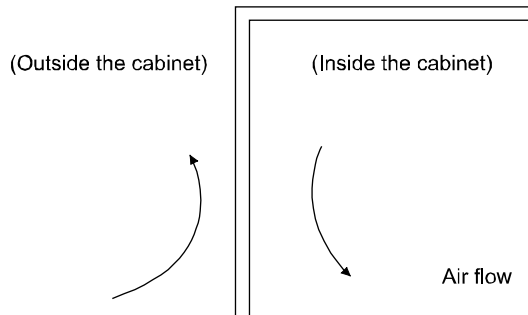

Fig. 10.2 Temperature distribution in an enclosed type cabinet

When air flows along the outer wall of the cabinet, effective heat exchange will be possible, because the temperature slope inside and outside the cabinet will be steeper.

10. CHARACTERISTICS

10.3 Dynamic brake characteristics

CAUTION

- The coasting distance is a theoretically calculated value which ignores the running load such as friction. The calculated value will be longer than the actual distance. If an enough braking distance is not provided, a moving part may crash into the stroke end, which is very dangerous. Install the anti-crash mechanism such as an air brake or an electric/mechanical stopper such as a shock absorber to reduce the shock of moving parts.

POINT

- Do not use dynamic brake for stop in a normal operation as it is the function for stop in emergency.
- For a machine operating at the recommended load to motor inertia ratio or less, the estimated number of usage times of the dynamic brake is 1000 times while the machine decelerates from the rated speed to a stop once in 10 minutes.
- Be sure to enable EM1 (Forced stop 1) after servo motor stops when using EM1 (Forced stop 1) frequently in other than emergency.

10. CHARACTERISTICS

10.3.1 Dynamic brake operation

(1) Calculation of coasting distance

Fig. 10.3 shows the pattern in which the servo motor comes to a stop when the dynamic brake is operated. Use equation 10.2 to calculate an approximate coasting distance to a stop. The dynamic brake time constant \ddot{A} varies with the servo motor and machine operation speeds. (Refer to (2) in this section.)

A working part generally has a friction force. Therefore, actual coasting distance will be shorter than a maximum coasting distance calculated with the following equation.

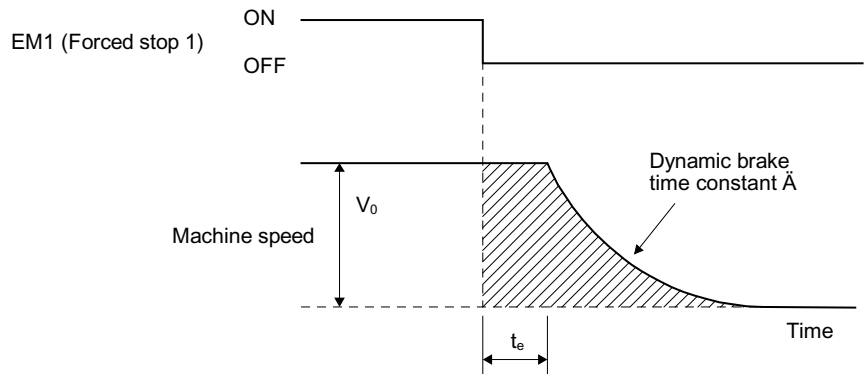

Fig. 10.3 Dynamic brake operation diagram

$$L_{\max} = \frac{V_0}{60} \cdot \left\{ t_e + \tau \left(1 + \frac{J_L}{J_M} \right) \right\} \dots \dots \dots (10.2)$$

- L_{\max} : Maximum coasting distance [mm]
- V_0 : Machine's fast feed speed [mm/min]
- J_M : Moment of inertia of the servo motor [$\times 10^{-4}$ kg·m²]
- J_L : Load moment of inertia converted into equivalent value on servo motor shaft [$\times 10^{-4}$ kg·m²]
- \ddot{A} : Dynamic brake time constant [s]
- t_e : Delay time of control section [s]

There is internal relay delay time of about 10 ms.

(2) Dynamic brake time constant

The following shows necessary dynamic brake time constant \ddot{A} for equation 10.2.

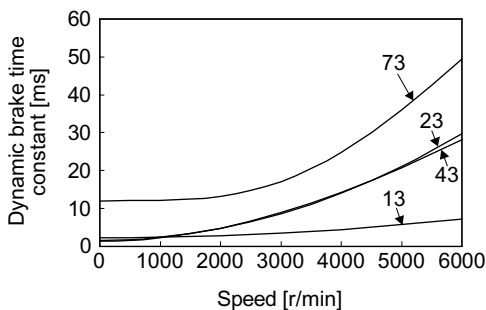

HG-KN series

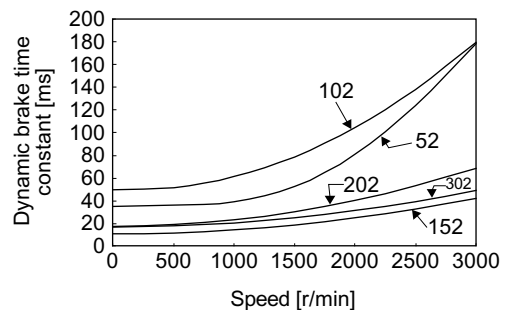

HG-SN series

10. CHARACTERISTICS

10.3.2 Permissible load to motor inertia when the dynamic brake is used

Use the dynamic brake under the load to motor inertia ratio indicated in the following table. If the ratio is higher than this value, the dynamic brake may burn. If there is a possibility that the ratio may exceed the value, contact your local sales office.

The values of the permissible load to motor inertia ratio in the table are the values at the maximum rotation speed of the servo motor.

Servo motor	Permissible load to motor inertia ratio [multiplier]
HG-KN13_	30
HG-KN23_	
HG-KN43_	
HG-KN73_	
HG-SN52_	
HG-SN102_	
HG-SN152_	24
HG-SN202_	16
HG-SN302_	

10.4 Cable bending life

The bending life of the cables is shown below. This graph calculated values. Since they are not guaranteed values, provide a little allowance for these values.

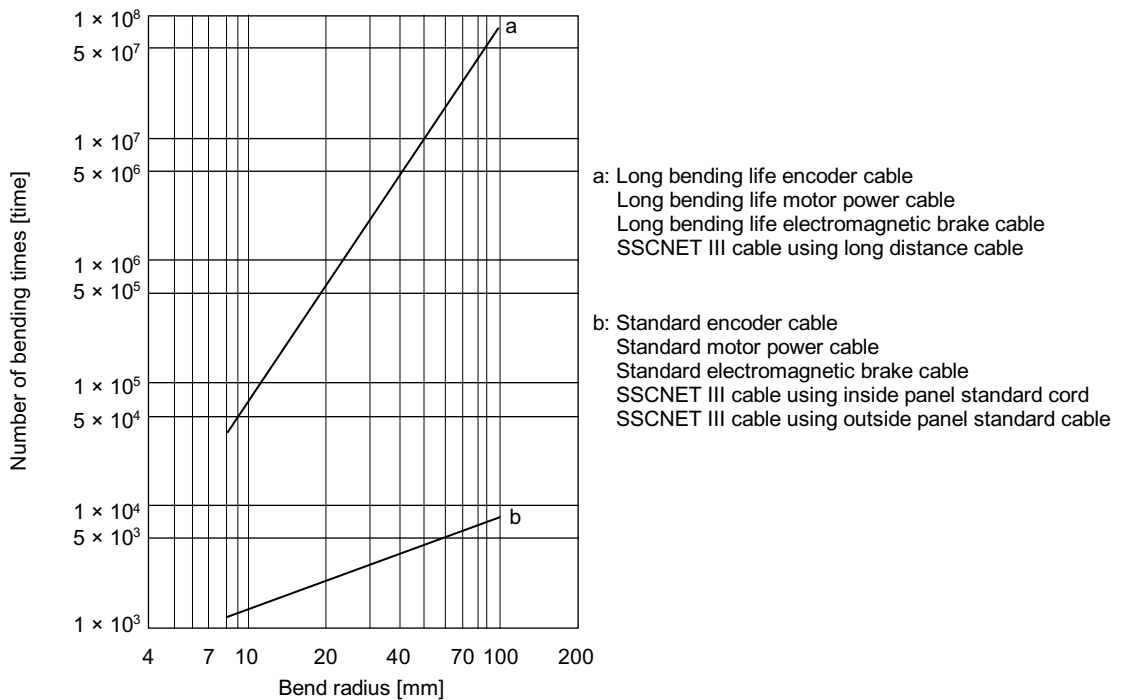

10. CHARACTERISTICS

10.5 Inrush current at power-on

POINT
● For a servo amplifier of 400 W or less, the inrush current values can change depending on frequency of turning on/off the power and ambient temperature.

The following table indicates the inrush currents (reference data) that will flow when 240 V AC is applied at the power supply capacity of 2500 kVA and the wiring length of 1 m. Even when you use a 1-phase 200 V AC power supply with MR-JE-10B to MR-JE-200B, the inrush currents will be the same.

Servo amplifier	Inrush currents (A _{0-P})
MR-JE-10B, MR-JE-20B, MR-JE-40B	32 A (attenuated to approx. 3 A in 20 ms)
MR-JE-70B, MR-JE-100B	36 A (attenuated to approx. 7 A in 20 ms)
MR-JE-200B, MR-JE-300B	102 A (attenuated to approx. 12 A in 20 ms)

Since large inrush currents flow in the power supplies, always use molded-case circuit breakers and magnetic contactors. (Refer to section 11.7.)

When circuit protectors are used, it is recommended that the inertia delay type, which is not tripped by an inrush current, be used.

11. OPTIONS AND PERIPHERAL EQUIPMENT

11. OPTIONS AND PERIPHERAL EQUIPMENT

 WARNING	<ul style="list-style-type: none">● Before connecting options and peripheral equipment, turn off the power and wait for 15 minutes or more until the charge lamp turns off. Otherwise, an electric shock may occur. In addition, when confirming whether the charge lamp is off or not, always confirm it from the front of the servo amplifier.
--	--

 CAUTION	<ul style="list-style-type: none">● Use the specified peripheral equipment and options to prevent a malfunction or a fire.
--	--

POINT
<ul style="list-style-type: none">● We recommend using HIV wires to wire the servo amplifiers, options, and peripheral equipment. Therefore, the recommended wire sizes may differ from those used for the previous servo amplifiers.

11.1 Cable/connector sets

POINT
<ul style="list-style-type: none">● The IP rating indicated for cables and connectors is their protection against ingress of dust and raindrops when they are connected to a servo amplifier or servo motor. If the IP rating of the cable, connector, servo amplifier and servo motor vary, the overall IP rating depends on the lowest IP rating of all components.

Please purchase the cable and connector options indicated in this section for this servo amplifier.





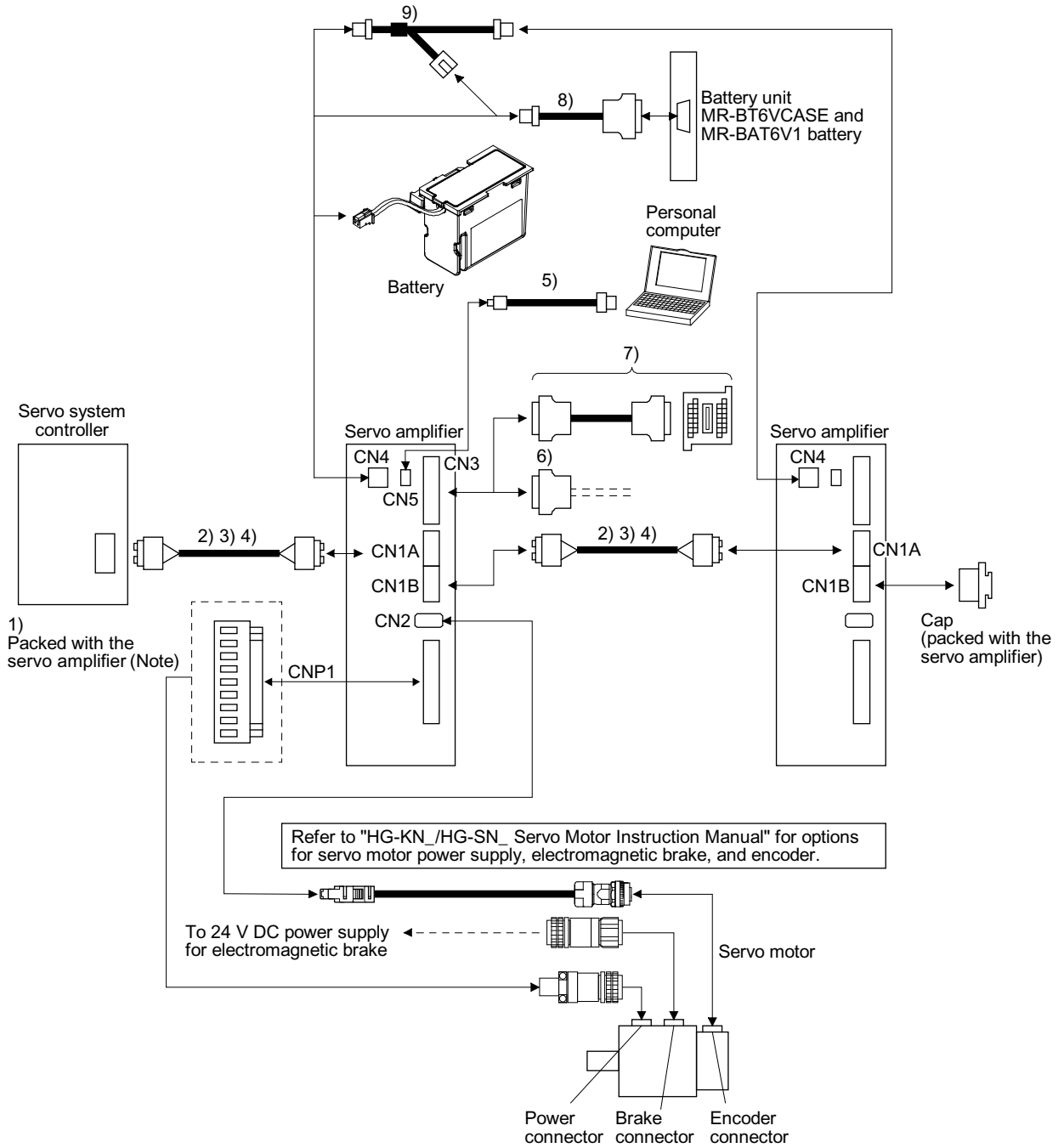

11. OPTIONS AND PERIPHERAL EQUIPMENT

11.1.1 Combinations of cable/connector sets

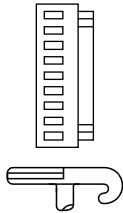
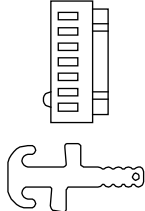

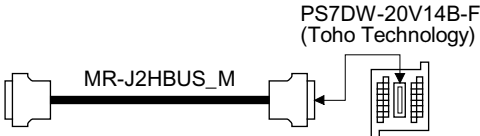

Note. Connectors for 1 kW or less. Refer to section 3.3.3 (1) (b) for 2 kW or more.

11. OPTIONS AND PERIPHERAL EQUIPMENT

No.	Product name	Model	Description	Application	
1)	Servo amplifier CNP1 power connector	MR-JECNP1-01	Connector for CNP1: 09JFAT-SAXGDK-H5.0 (JST) Applicable wire size: AWG 18 to 14 Insulator OD: to 3.9 mm Open tool: J-FAT-OT (N) or J-FAT-OT (JST)	 Supplied with servo amplifiers of 1 kW or less	
		MR-JECNP1-02	Connector for CNP1: 06(7-4)JFAT-SAXGFK-XL (JST) Applicable wire size: AWG 16 to 10 Insulator OD: to 4.7 mm Open tool: J-FAT-OT-EXL (JST)		 Supplied with servo amplifiers of 2 kW and 3 kW
	Servo amplifier CNP2 power connector	MR-JECNP2-02	Connector for CNP2: 03JFAT-SAXGFK-XL (JST) Applicable wire size: AWG 16 to 10 Insulator OD: to 4.7 mm		
2)	SSCNET III cable	MR-J3BUS_M Cable length: 0.15 m to 3 m (Refer to section 11.1.2.)	Connector: PF-2D103 (JAE)	Connector: PF-2D103 (JAE)	Standard cord inside cabinet
3)	SSCNET III cable	MR-J3BUS_M-A Cable length: 5 m to 20 m (Refer to section 11.1.2.)			Standard cable outside cabinet
4)	SSCNET III cable	MR-J3BUS_M-B Cable length: 30 m to 50 m (Refer to section 11.1.2.)	Connector: CF-2D103-S (JAE)	Connector: CF-2D103-S (JAE)	Long distance cable
					
5)	USB cable	MR-J3USBCBL3M Cable length: 3 m	CN5 connector mini-B connector (5 pins)	Personal computer connector A connector	For connection with PC-AT compatible personal computer
					
6)	Connector set	MR-CCN1	Connector: 10120-3000PE Shell kit: 10320-52F0-008 (3M or equivalent)		
7)	Junction terminal block (recommended)		 PS7DW-20V14B-F (Toho Technology)		
		<p>The junction terminal block PS7DW-20V14B-F is not an option. To use the junction terminal block, option MR-J2HBUS_M is necessary. Refer to section 11.3 for details.</p>			

11. OPTIONS AND PERIPHERAL EQUIPMENT

No.	Product name	Model	Description		Application
8)	Battery cable	MR-BT6V1CBL_M Cable length: 0.3 m or 1 m (Refer to section 11.1.3.)	Housing: PAP-02V-O Contact: SPHD-001G-P0.5 (JST)	Connector: 10114-3000PE Shell kit: 10314-52F0-008 (3M or equivalent)	For connection with battery unit
					
9)	Junction battery cable	MR-BT6V2CBL_M Cable length: 0.3 m or 1 m (Refer to section 11.1.3.)	Housing: PAP-02V-O Contact: SPHD-001G-P0.5 (JST)	Housing: PALR-02VF-O Contact: SPAL-001GU-P0.5 (JST)	For battery junction
					
			Housing: PAP-02V-O Contact: SPHD-001G-P0.5 (JST)		

11. OPTIONS AND PERIPHERAL EQUIPMENT

11.1.2 SSCNET III cable

POINT
<ul style="list-style-type: none"> ● Do not look directly at the light generated from the CN1A connector and CN1B connector of servo amplifier or the end of SSCNET III cable. The light can be a discomfort when it enters the eye. ● Refer to app. 5 for a long distance cable over 50 m and ultra-long bending life cable.

(1) Model explanations

The numbers in the cable length field of the table indicate the symbol filling the underline "_" in the cable model. The cables of the lengths with the numbers are available.

Cable model	Cable length											Bending life	Application and remark
	0.15 m	0.3 m	0.5 m	1 m	3 m	5 m	10 m	20 m	30 m	40 m	50 m		
MR-J3BUS_M	015	03	05	1	3							Standard	Using standard cord inside cabinet
MR-J3BUS_M-A						5	10	20				Standard	Using standard cable outside cabinet
(Note) MR-J3BUS_M-B									30	40	50	Long bending life	Using long distance cable

Note. For cables of 30 m or shorter, contact your local sales office.

(2) Specifications

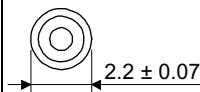
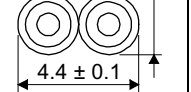
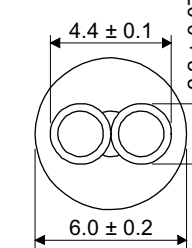
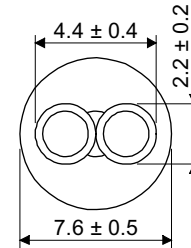
		Description			
SSCNET III cable model		MR-J3BUS_M		MR-J3BUS_M-A	MR-J3BUS_M-B
SSCNET III cable length		0.15 m	0.3 m to 3 m	5 m to 20 m	30 m to 50 m
Optical cable (cord)	Minimum bending radius	25 mm		Enforced covering cable: 50 mm Cord: 25 mm	Enforced covering cable: 50 mm Cord: 30 mm
	Tension strength	70 N	140 N	420 N (Enforced covering cable)	980 N (Enforced covering cable)
	Temperature range for operation (Note)	-40 °C to 85 °C			-20 °C to 70 °C
	Ambience	Indoors (no direct sunlight), no solvent or oil			
	Appearance [mm]				

Note. This temperature range for use is the value for optical cable (cord) only. The temperature condition for the connector is the same as that for the servo amplifier.

11. OPTIONS AND PERIPHERAL EQUIPMENT

- (3) Dimensions
 - (a) MR-J3BUS015M

[Unit: mm]

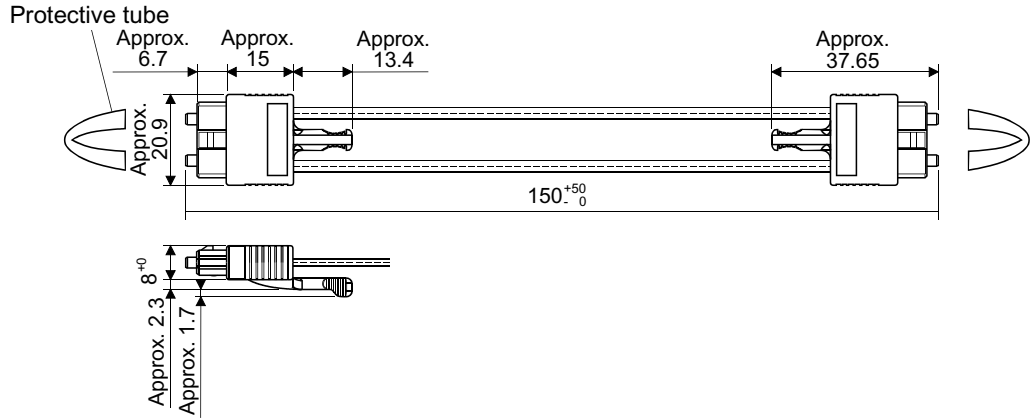

- (b) MR-J3BUS03M to MR-J3BUS3M

Refer to the table shown in (1) in this section for cable length (L).

[Unit: mm]

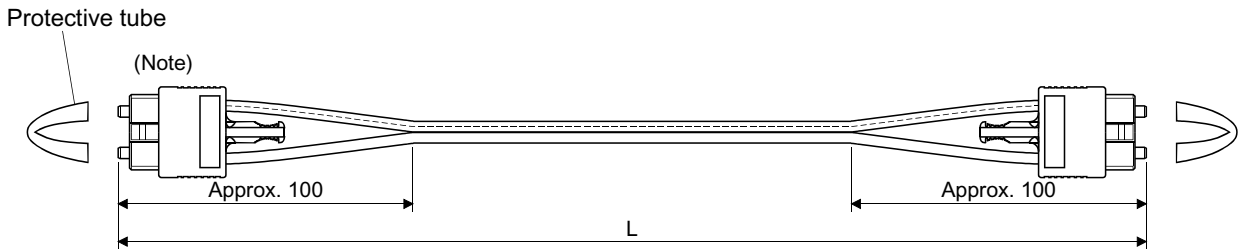

Note. Dimension of connector part is the same as that of MR-J3BUS015M.

- (c) MR-J3BUS5M-A to MR-J3BUS20M-A/MR-J3BUS30M-B to MR-J3BUS50M-B

Refer to the table shown in (1) in this section for cable length (L).

SSCNET III cable	Variable dimensions [mm]	
	A	B
MR-J3BUS5M-A to MR-J3BUS20M-A	100	30
MR-J3BUS30M-B to MR-J3BUS50M-B	150	50

[Unit: mm]

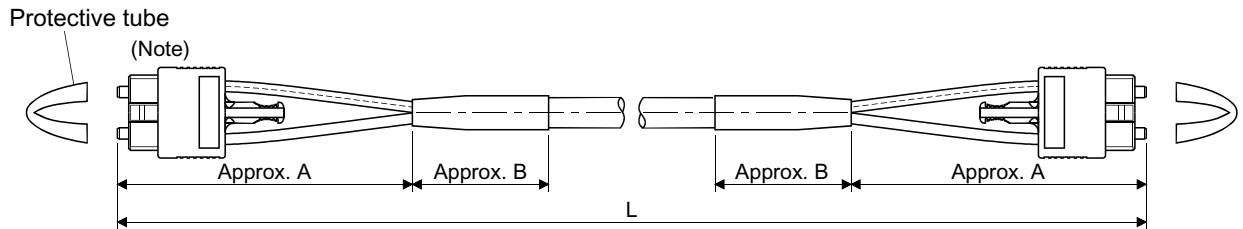

Note. Dimension of connector part is the same as that of MR-J3BUS015M.

11. OPTIONS AND PERIPHERAL EQUIPMENT

11.1.3 Battery cable and junction battery cable

(1) Model explanations

The numbers in the cable length field of the table indicate the symbol filling the underline "_" in the cable model. The cables of the lengths with the numbers are available.

Cable model	Cable length		Bending life	Application and remark
	0.3 m	1 m		
MR-BT6V1CBL_M	03	1	Standard	For connecting to MR-BT6VCASE
MR-BT6V2CBL_M	03	1	Standard	For junction

(2) MR-BT6V1CBL_M

(a) Appearance

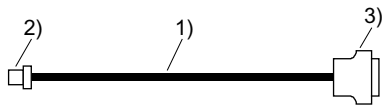

Components	Description
1) Cable	VSVC 7/0.18 × 2C
2) Connector	Housing: PAP-02V-O Contact: SPHD-001G-P0.5 (JST)
3) Connector	Connector: 10114-3000PE Shell kit: 10314-52F0-008 (3M or equivalent)

(b) Internal wiring diagram

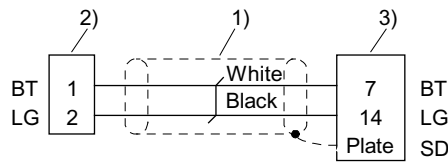

(3) MR-BT6V2CBL_M

(a) Appearance

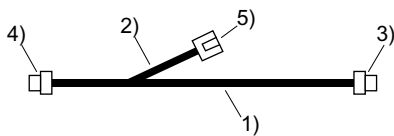

Components	Description
1) Cable	VSVC 7/0.18 × 2C
2) Cable	
3) Connector	Housing: PAP-02V-O
4) Connector	Contact: SPHD-001G-P0.5 (JST)
5) Connector	Housing: PALR-02VF-O Contact: SPAL-001GU-P0.5 (JST)

(b) Internal wiring diagram

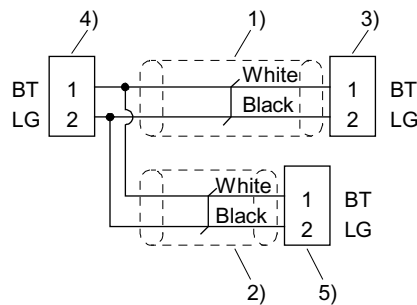

11. OPTIONS AND PERIPHERAL EQUIPMENT

11.2 Regenerative option

 CAUTION	<p>● Do not use servo amplifiers with regenerative options other than the combinations specified below. Otherwise, it may cause a fire.</p>
--	---

11.2.1 Combination and regenerative power

The power values in the table are resistor-generated powers and not rated powers.

Servo amplifier	Regenerative power [W]					
	Built-in regenerative resistor	MR-RB032 [40 Ω]	MR-RB12 [40 Ω]	MR-RB30 [13 Ω]	MR-RB32 [40 Ω]	(Note) MR-RB50 [13 Ω]
MR-JE-10B		30				
MR-JE-20B		30	100			
MR-JE-40B	10	30	100			
MR-JE-70B	20	30	100		300	
MR-JE-100B	20	30	100		300	
MR-JE-200B	100			300		500
MR-JE-300B	100			300		500

Note. Always install a cooling fan.

11. OPTIONS AND PERIPHERAL EQUIPMENT

11.2.2 Selection of regenerative option

Use the following method when regeneration occurs continuously in vertical motion applications or when it is desired to make an in-depth selection of the regenerative option.

(1) Regenerative energy calculation

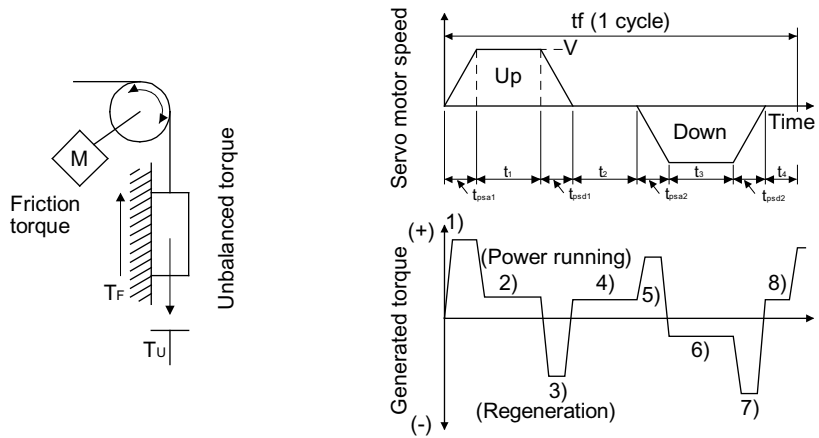

Formulas for calculating torque and energy in operation

Regenerative power	Torque applied to servo motor [N·m] (Note)	Energy E [J]
1)	$T_1 = \frac{(J_L \cdot \eta + J_M) \cdot V}{9.55 \cdot 10^4} \cdot \frac{1}{t_{psa1}} + T_U + T_F$	$E_1 = \frac{0.1047}{2} \cdot V \cdot T_1 \cdot t_{psa1}$
2)	$T_2 = T_U + T_F$	$E_2 = 0.1047 \cdot V \cdot T_2 \cdot t_1$
3)	$T_3 = \frac{-(J_L \cdot \eta + J_M) \cdot V}{9.55 \cdot 10^4} \cdot \frac{1}{t_{psd1}} + T_U + T_F$	$E_3 = \frac{0.1047}{2} \cdot V \cdot T_3 \cdot t_{psd1}$
4), 8)	$T_4, T_8 = T_U$	$E_4, E_8 = 0$ (No regeneration)
5)	$T_5 = \frac{(J_L \cdot \eta + J_M) \cdot V}{9.55 \cdot 10^4} \cdot \frac{1}{t_{psa2}} - T_U + T_F$	$E_5 = \frac{0.1047}{2} \cdot V \cdot T_5 \cdot t_{psa2}$
6)	$T_6 = -T_U + T_F$	$E_6 = 0.1047 \cdot V \cdot T_6 \cdot t_3$
7)	$T_7 = \frac{-(J_L \cdot \eta + J_M) \cdot V}{9.55 \cdot 10^4} \cdot \frac{1}{t_{psd2}} - T_U + T_F$	$E_7 = \frac{0.1047}{2} \cdot V \cdot T_7 \cdot t_{psd2}$

Note. η : Drive system efficiency

From the calculation results in 1) to 8), find the absolute value (Es) of the sum total of negative energies.

11. OPTIONS AND PERIPHERAL EQUIPMENT

(2) Losses of servo motor and servo amplifier in regenerative mode

The following table lists the efficiencies and other data of the servo motor and servo amplifier in the regenerative mode.

Servo amplifier	Inverse efficiency [%]	Capacitor charging [J]
MR-JE-10B	55	11
MR-JE-20B	75	11
MR-JE-40B	85	14
MR-JE-70B	85	25

Servo amplifier	Inverse efficiency [%]	Capacitor charging [J]
MR-JE-100B	85	25
MR-JE-200B	85	42
MR-JE-300B	85	42

Inverse efficiency (η_m): Efficiency including some efficiencies of the servo motor and servo amplifier when rated (regenerative) torque is generated at rated speed. The efficiency varies with the speed and generated torque. In addition, the characteristics of the electrolytic capacitor change over the years, and thus the inverse efficiency should have a large margin of approximately 10%.

Capacitor charging (E_c): Energy charged into the electrolytic capacitor in the servo amplifier

Subtract the capacitor charging from the result of multiplying the sum total of regenerative energies by the inverse efficiency to calculate the energy consumed by the regenerative option.

$$ER [J] = \eta_m \cdot E_s - E_c$$

Calculate the power consumption of the regenerative option on the basis of one-cycle operation period t_f [s] to select the necessary regenerative option.

$$PR [W] = ER/t_f$$

11.2.3 Parameter setting

Set [Pr. PA02] according to the option to be used.

[Pr. PA02]

0	0		
---	---	--	--

- Regenerative option selection
- 00: Regenerative option is not used.
 - For servo amplifier of 200 W or less, regenerative resistor is not used.
 - For servo amplifier of 0.4 kW to 3 kW, built-in regenerative resistor is used.
 - 02: MR-RB032
 - 03: MR-RB12
 - 04: MR-RB32
 - 05: MR-RB30
 - 06: MR-RB50 (Cooling fan is required)

11. OPTIONS AND PERIPHERAL EQUIPMENT

11.2.4 Connection of regenerative option

POINT
<ul style="list-style-type: none">● When you use a regenerative option with an MR-JE-40B to MR-JE-100B, remove the built-in regenerative resistor and wiring from the servo amplifier.● When MR-RB50 is used, a cooling fan is required to cool it. The cooling fan should be prepared by the customer.● For the wire sizes used for wiring, refer to section 11.6.● A built-in regenerative resistor should not be mounted or removed frequently.● When you remount a built-in regenerative resistor, check the lead wires of the built-in regenerative resistor for scratches or cracks.

The regenerative option generates heat of 100 °C higher than the ambient temperature. Fully consider heat dissipation, installation position, wires used, etc. before installing the option. For wiring, use flame-retardant wires or make the wires flame retardant and keep them away from the regenerative option. Use twisted wires of up to 5 m for connecting the servo amplifier.

11. OPTIONS AND PERIPHERAL EQUIPMENT

(1) MR-JE-100B or less

When you use a regenerative option for MR-JE-40B to MR-JE-100B, remove wirings of P+ and C, remove the built-in regenerative resistor, and then connect the regenerative option between P+ and C. G3 and G4 are terminals for the thermal sensor. Between G3 and G4 is opened when the regenerative option overheats abnormally.

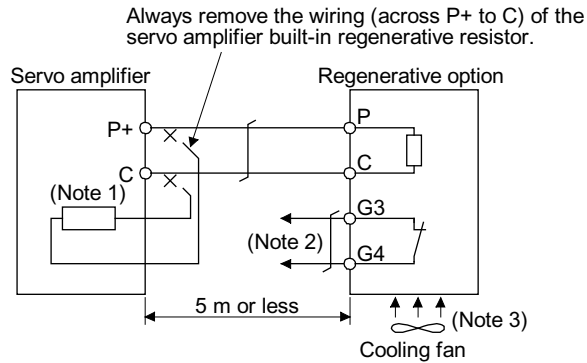

Note 1. The built-in regenerative resistor is not provided for MR-JE-10B and MR-JE-20B.

2. Configure a sequence which will switch off the magnetic contactor when abnormal heating occurs.

G3-G4 contact specifications

Maximum voltage: 120 V AC/DC

Maximum current: 0.5 A/4.8 V DC

Maximum capacity: 2.4 VA

3. When the ambient temperature is higher than 55 °C and the regenerative load ratio is higher than 60% in MR-RB32, forcibly cool the air with a cooling fan (1.0 m³/min or more, 92 mm × 92 mm). A cooling fan is not required if the ambient temperature is 35 °C or lower. (A cooling fan is required for the shaded area in the following graph.)

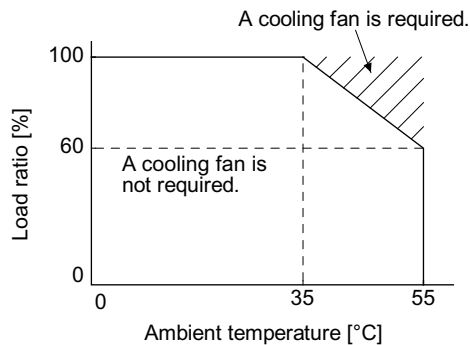

11. OPTIONS AND PERIPHERAL EQUIPMENT

To remove the built-in regenerative resistor mounted on the back of MR-JE-40B to MR-JE-100B, refer to the following illustration and follow the procedures 1) to 3).

- 1) Disconnect the wirings of the built-in regenerative resistor from the power connector (CNP1).
(Refer to section 3.3.3 (2) (b).)
- 2) Remove the wirings of the built-in regenerative resistor from the closest position to the power connector (CNP1) in order. Please pay full attention not to break the wirings.
- 3) Remove the screw fixing the built-in regenerative resistor and dismount the built-in regenerative resistor.

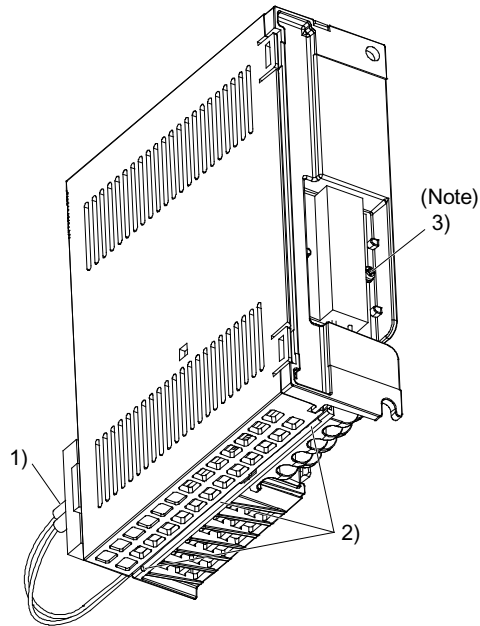

Note. Screw size: M3
Tightening torque: 0.72 [N•m]

11. OPTIONS AND PERIPHERAL EQUIPMENT

(2) MR-JE-200B or more

Always remove the wiring from across P+ to D and mount the regenerative option across P+ to C. G3 and G4 are terminals for the thermal sensor. Between G3 and G4 is opened when the regenerative option overheats abnormally.

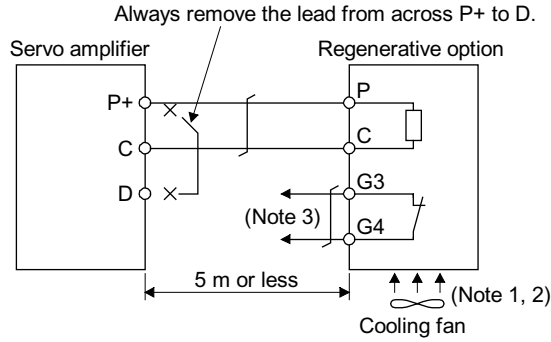

- Note 1. When using the MR-RB50, forcibly cool it with a cooling fan (1.0 m³/min or more, 92 mm × 92 mm).
- Note 2. When the ambient temperature is higher than 55 °C and the regenerative load ratio is higher than 60% in MR-RB30, forcibly cool the air with a cooling fan (1.0 m³/min or more, 92 mm × 92 mm). A cooling fan is not required if the ambient temperature is 35 °C or lower. (A cooling fan is required for the shaded area in the following graph.)

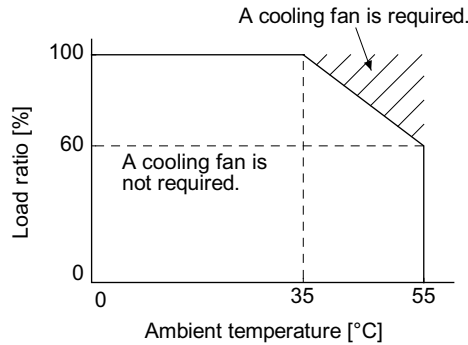

3. Configure a sequence which will switch off the magnetic contactor when abnormal heating occurs.

G3-G4 contact specifications

- Maximum voltage: 120 V AC/DC
- Maximum current: 0.5 A/4.8 V DC
- Maximum capacity: 2.4 VA

11. OPTIONS AND PERIPHERAL EQUIPMENT

11.2.5 Dimensions

(1) MR-RB12

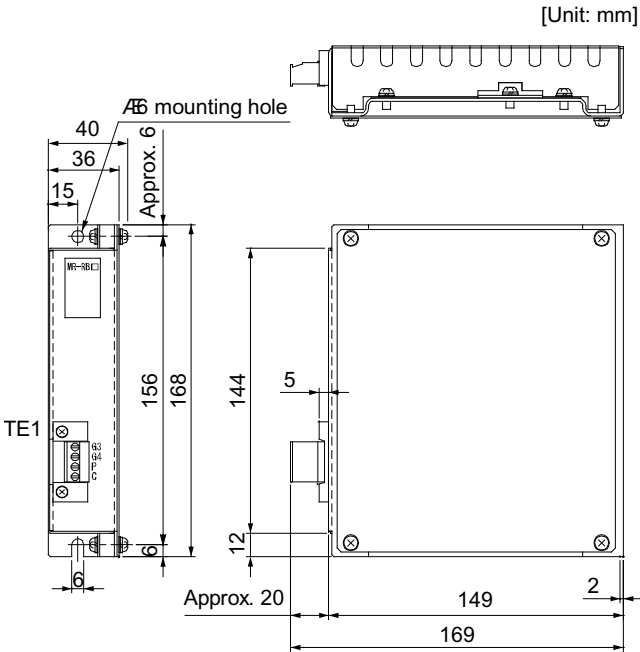

- TE1 terminal block

G3
G4
P
C

Applicable wire size: 0.2 mm² to 2.5 mm² (AWG 24 to 12)

Tightening torque: 0.5 to 0.6 [N•m]

- Mounting screw

Screw size: M5

Tightening torque: 3.24 [N•m]

Mass: 1.1 [kg]

(2) MR-RB30/MR-RB32

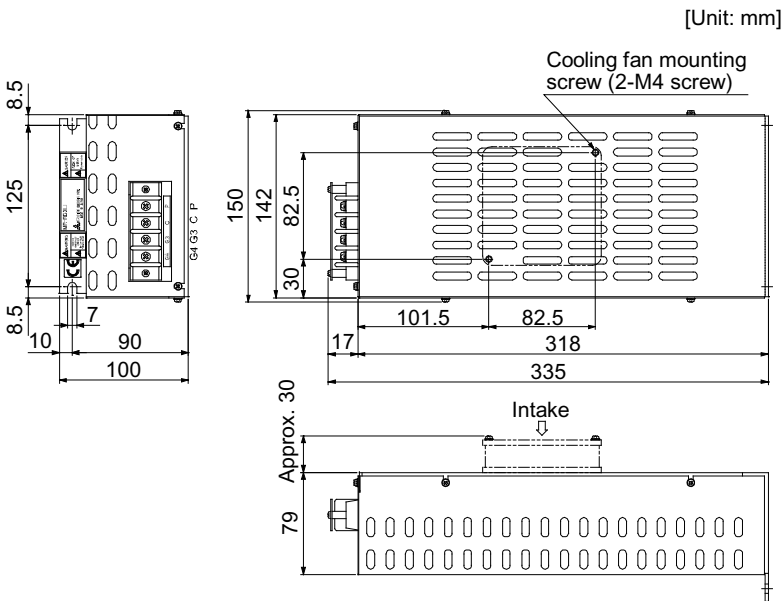

- Terminal block

P
C
G3
G4

Terminal screw size: M4

Tightening torque: 1.2 [N•m]

- Mounting screw

Screw size: M6

Tightening torque: 5.4 [N•m]

Mass: 2.9 [kg]

11. OPTIONS AND PERIPHERAL EQUIPMENT

(3) MR-RB50

[Unit: mm]

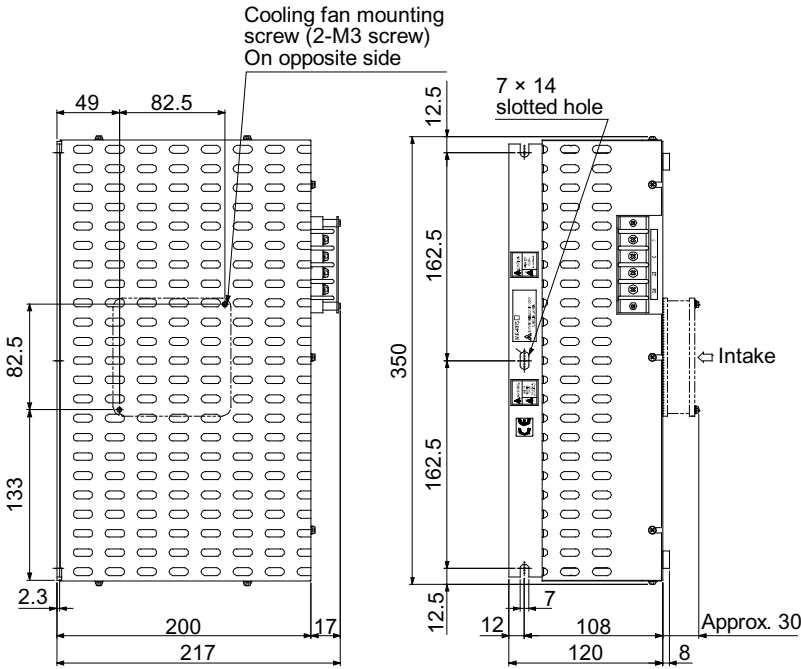

- Terminal block

P
C
G3
G4

Terminal screw size: M4
Tightening torque: 1.2 [N•m]

- Mounting screw
Screw size: M6
Tightening torque: 5.4 [N•m]

Mass: 5.6 [kg]

(4) MR-RB032

[Unit: mm]

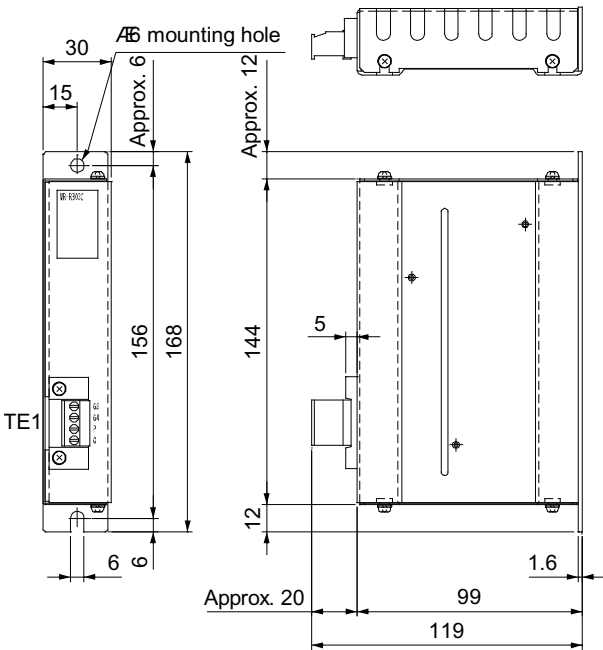

- TE1 terminal block

G3
G4
P
C

Applicable wire size: 0.2 mm² (AWG 24) to 2.5 mm² (AWG 12)
Tightening torque: 0.5 to 0.6 [N•m]

- Mounting screw
Screw size: M5
Tightening torque: 3.24 [N•m]

Mass: 0.5 [kg]

11. OPTIONS AND PERIPHERAL EQUIPMENT

11.3 Junction terminal block PS7DW-20V14B-F (recommended)

(1) Usage

Always use the junction terminal block (PS7DW-20V14B-F (Toho Technology)) with the option cable (MR-J2HBUS_M) as a set. A connection example is shown below.

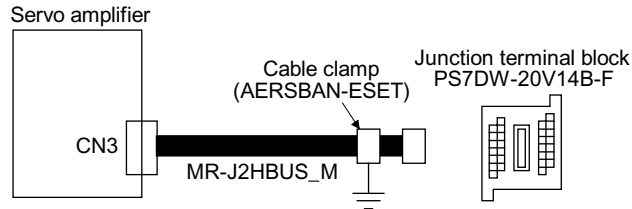

Ground the junction terminal block cable on the junction terminal block side with the supplied cable clamp fitting (AERSBAN-ESET). For the use of the cable clamp fitting, refer to section 11.10, (2) (c).

(2) Connection diagram of MR-J2HBUS_M cable and junction terminal block

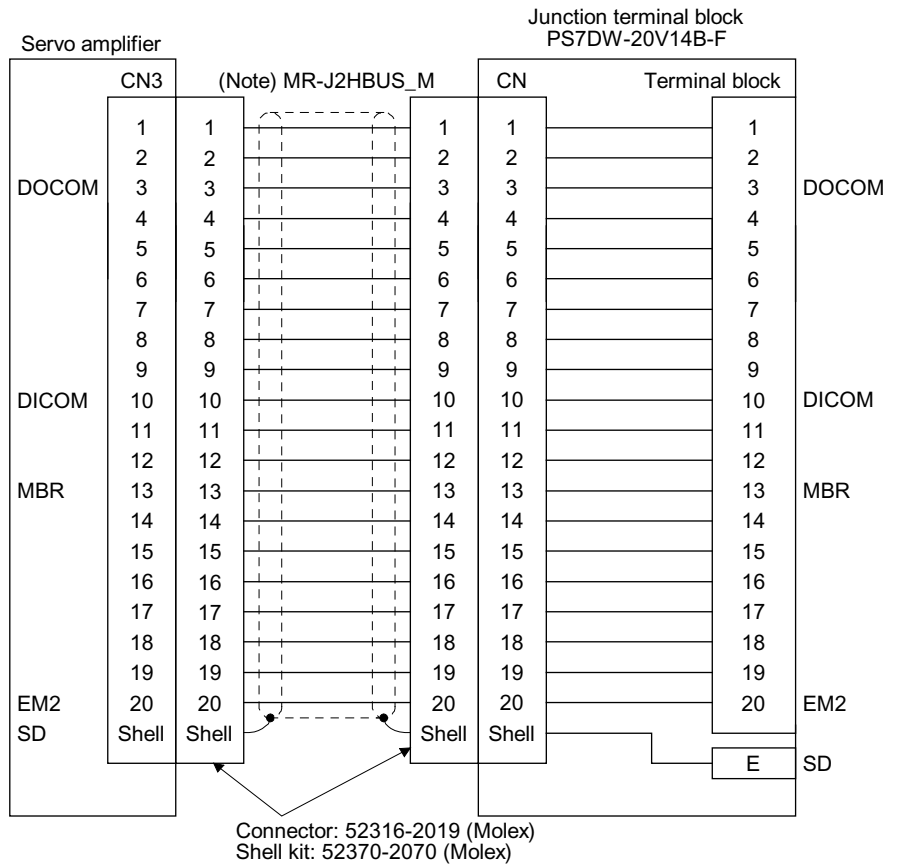

Note. A symbol indicating the cable length is put in _.

05: 0.5 m

1: 1 m

5: 5 m

11. OPTIONS AND PERIPHERAL EQUIPMENT

(3) Dimensions of junction terminal block

[Unit: mm]

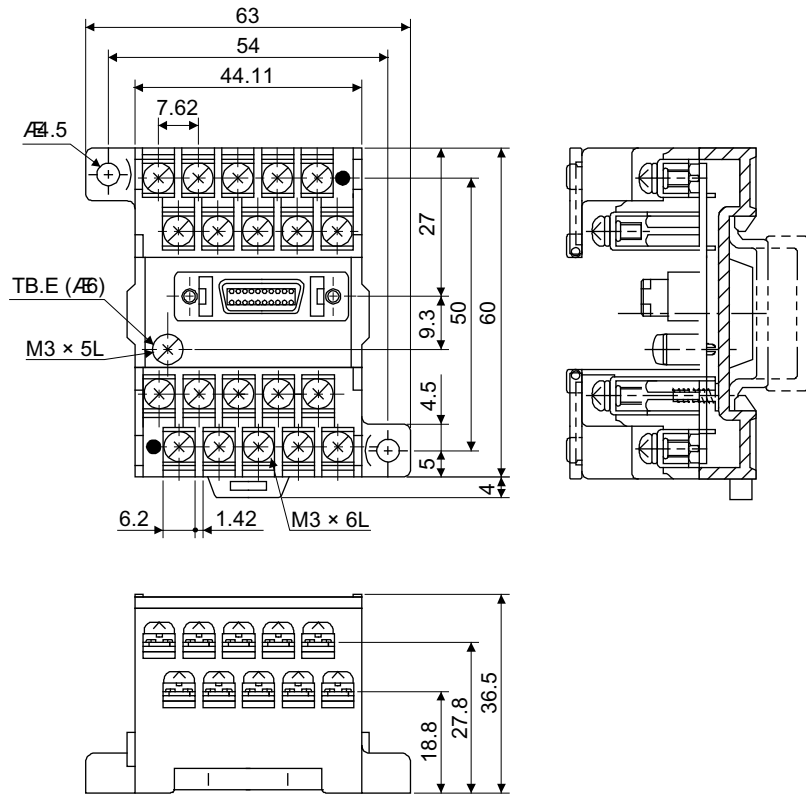

11.4 MR Configurator2

11.4.1 Engineering software

The following engineering software is compatible with this servo amplifier.

Engineering software	Manual
MR Configurator2 SW1DNC-MRC2-__	MR Configurator2 SW1DNC-MRC2-E Installation Guide (IB(NA)0300163ENG)

For the engineering software specifications and system configuration, refer to the installation guide.

11. OPTIONS AND PERIPHERAL EQUIPMENT

11.4.2 Precautions for using USB communication function

Note the following to prevent an electric shock and malfunction of the servo amplifier.

(1) Power connection of personal computer

Connect your personal computer with the following procedures.

(a) When using a personal computer with AC power supply

- 1) When using a personal computer with a three-core power plug or power plug with grounding wire, use a three-pin socket or ground the grounding wire.
- 2) When your personal computer has two-core plug and has no grounding wire, connect the personal computer to the servo amplifier with the following procedures.
 - a) Disconnect the power plug of the personal computer from an AC power socket.
 - b) Check that the power plug was disconnected and connect the device to the servo amplifier.
 - c) Connect the power plug of the personal computer to the AC power socket.

(b) When using a personal computer with battery

You can use as it is.

(2) Connection with other devices using servo amplifier communication function

When the servo amplifier is charged with electricity due to connection with a personal computer and the charged servo amplifier is connected with other devices, the servo amplifier or the connected devices may malfunction. Connect the servo amplifier and other devices with the following procedures.

- (a) Shut off the power of the device for connecting with the servo amplifier.
- (b) Shut off the power of the servo amplifier which was connected with the personal computer and check the charge lamp is off.
- (c) Connect the device with the servo amplifier.
- (d) Turn on the power of the servo amplifier and the device.

11. OPTIONS AND PERIPHERAL EQUIPMENT

11.5 Battery

POINT	
●	Refer to app. 2 and 3 for battery transportation and the new EU Battery Directive.

The battery is used to construct an absolute position detection system. For construction of an absolute position detection system, refer to chapter 12.

11.5.1 Selection of battery

Applicable batteries differ depending on servo amplifiers. Select a proper battery.

(1) Applications of the batteries

Model	Name	Application	Built-in battery
MR-BAT6V1SET-A	Battery	For absolute position data-hold	MR-BAT6V1
MR-BT6VCASE	Battery case	For absolute position data-hold for multiple-axis servo motors	MR-BAT6V1

(2) Combination of battery and servo amplifier

Model	MR-JE-_B
MR-BAT6V1SET-A	○
MR-BT6VCASE	○

11. OPTIONS AND PERIPHERAL EQUIPMENT

11.5.2 MR-BAT6V1SET-A battery

POINT
● For the specifications and the year and month of manufacture of the built-in MR-BAT6V1 battery, refer to section 11.5.4.

(1) Parts identification and dimensions

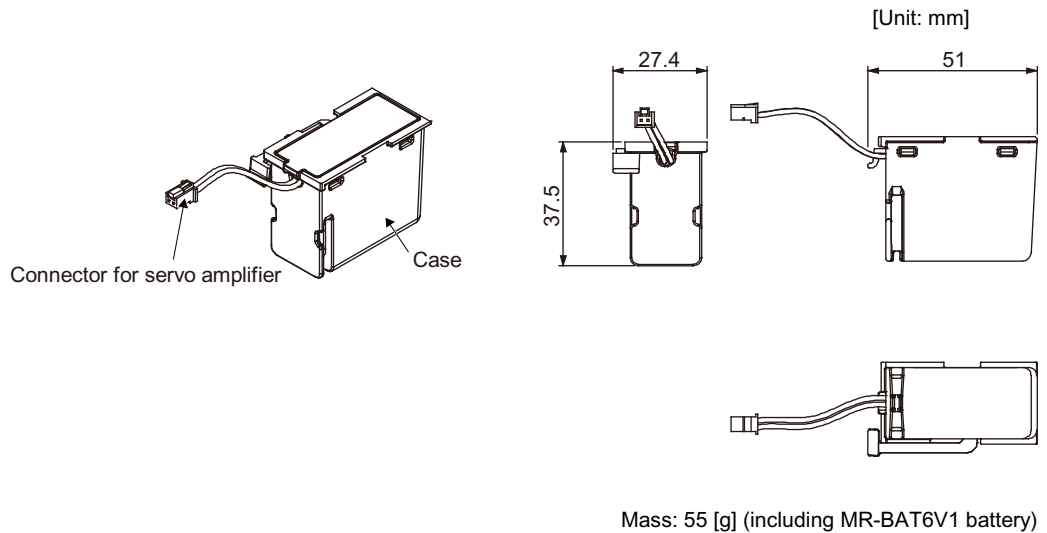

(2) Battery connection

Connect a battery as follows.

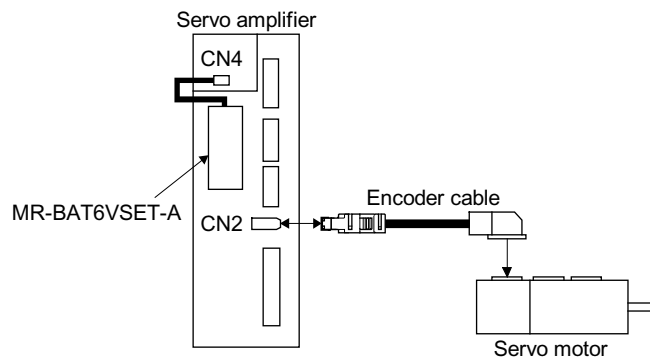

11. OPTIONS AND PERIPHERAL EQUIPMENT

(3) Battery replacement procedure

WARNING

- Before replacing a battery, turn off the power and wait for 15 minutes or more until the charge lamp turns off. Otherwise, an electric shock may occur. In addition, when confirming whether the charge lamp is off or not, always confirm it from the front of the servo amplifier.

CAUTION

- The internal circuits of the servo amplifier may be damaged by static electricity. Always take the following precautions.
 - Ground human body and work bench.
 - Do not touch the conductive areas, such as connector pins and electrical parts, directly by hand.

POINT

- Replacing a battery will erase the absolute position data.
- Before replacing batteries, check that the new battery is within battery life.

(a) Mounting method

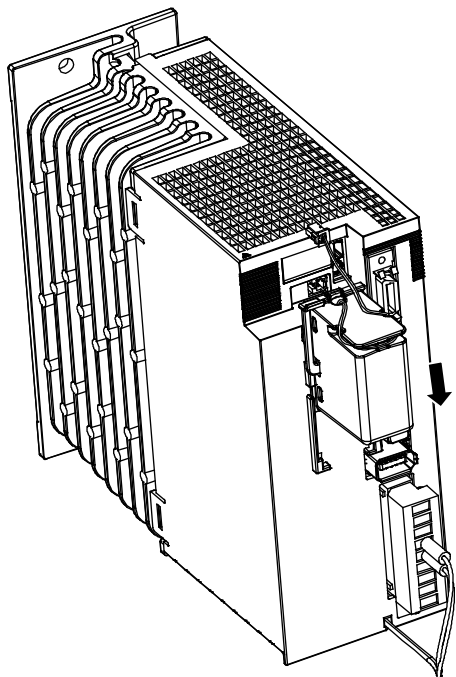

Pull down the battery along the rail.

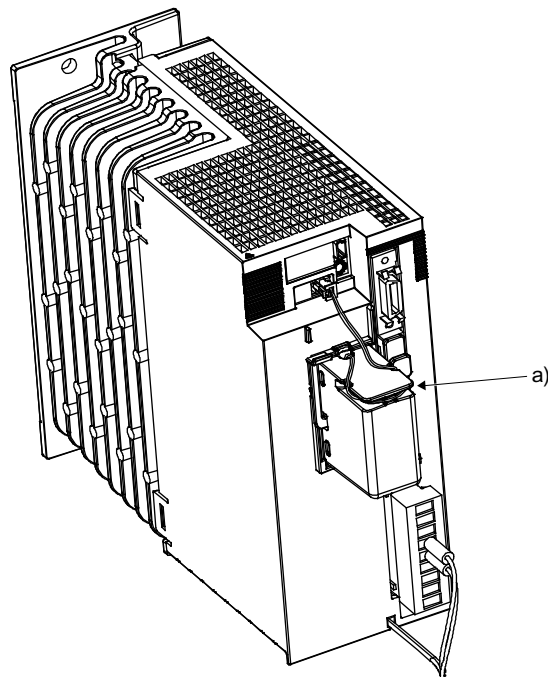

For MR-JE-100B or less, wrap the excess wire around a) of the battery.

11. OPTIONS AND PERIPHERAL EQUIPMENT

For MR-JE-200B or more, connect the battery cable as follows.

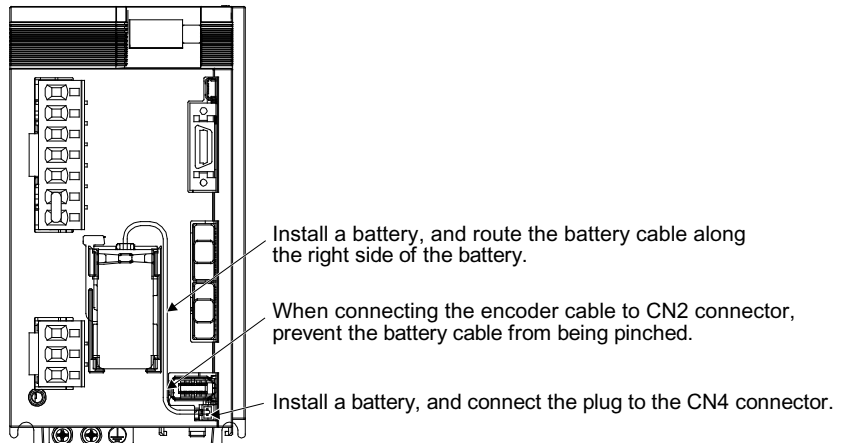

(b) Removal procedure

CAUTION

- Pulling out the connector of the battery without the lock release lever pressed may damage the CN4 connector of the servo amplifier or the connector of the battery.

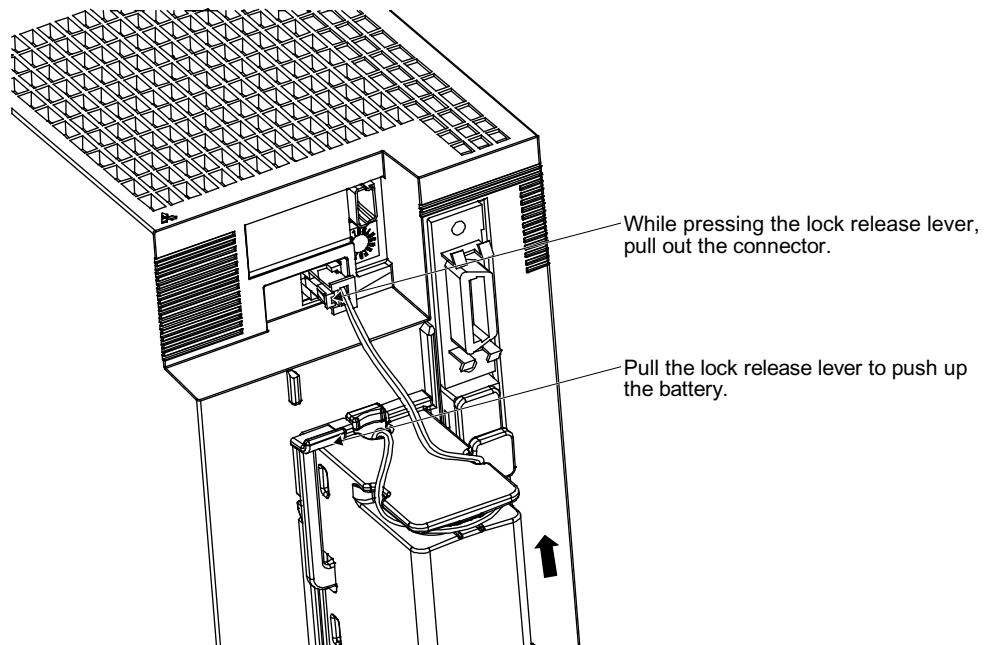

11. OPTIONS AND PERIPHERAL EQUIPMENT

(4) Replacement procedure of the built-in battery

When the MR-BAT6V1SET-A reaches the end of its life, replace the MR-BAT6V1 battery in the MR-BAT6V1SET-A.

1) Hold the tab and open the cover.

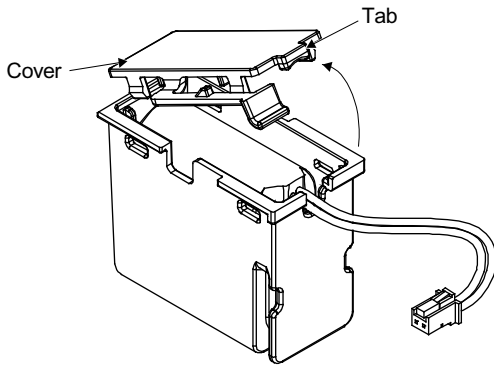

2) Replace the battery with a new MR-BAT6V1 battery.

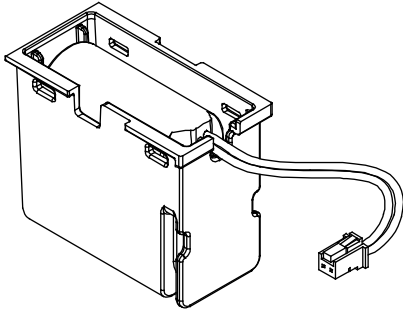

3) Press the cover until it is fixed with the projection of the locking part to close the cover.

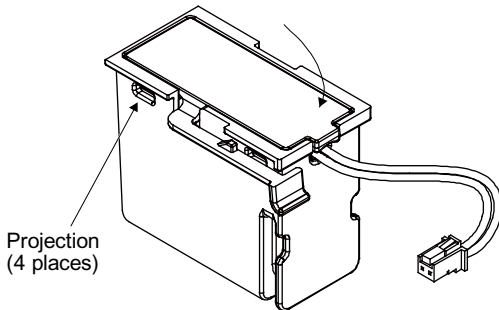

11. OPTIONS AND PERIPHERAL EQUIPMENT

11.5.3 MR-BT6VCASE battery case

POINT
<ul style="list-style-type: none"> ● The battery unit consists of an MR-BT6VCASE battery case and five MR-BAT6V1 batteries. ● For the specifications and the year and month of manufacture of the MR-BAT6V1 battery, refer to section 11.5.4.

MR-BT6VCASE is a case used for connecting and mounting five MR-BAT6V1 batteries. No battery is included in the battery case. Prepare MR-BAT6V1 batteries separately.

(1) Number of connectable servo motors

One MR-BT6VCASE case can hold the absolute position data of up to 8-axis servo motors. Servo motors in an incremental system are included as the axis numbers.

(2) Dimensions

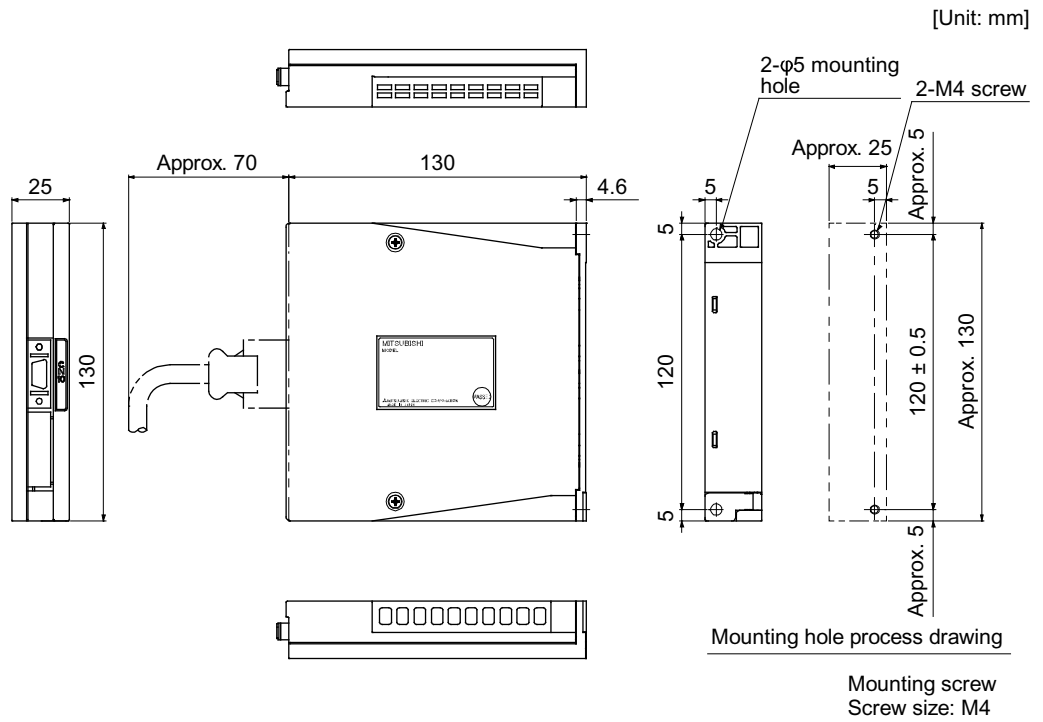

[Mass: 0.18 kg]

11. OPTIONS AND PERIPHERAL EQUIPMENT

(3) Battery connection

POINT
● One battery unit can be connected to up to 8-axis servo motors. Servo motors in an incremental system are included as the axis numbers.

(a) When using 1-axis servo amplifier

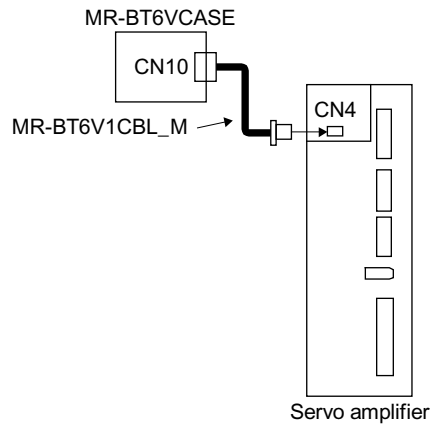

(b) When using up to 8-axis servo amplifiers

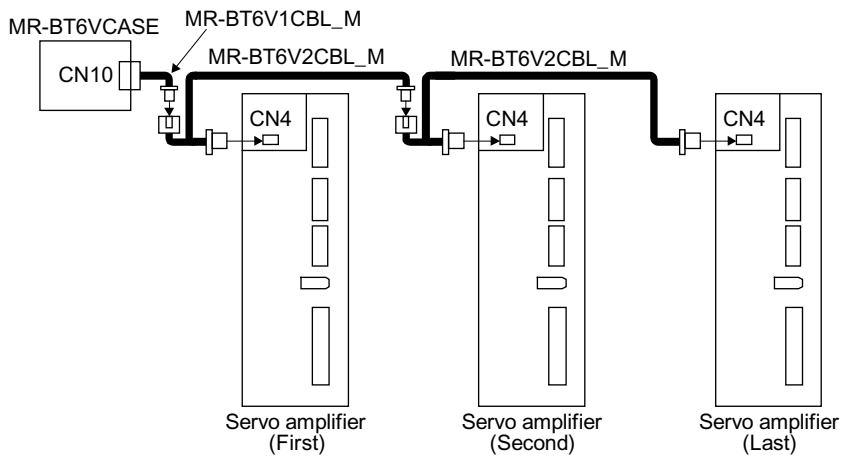

11. OPTIONS AND PERIPHERAL EQUIPMENT

(4) Battery replacement procedure

WARNING

- Before replacing a battery, turn off the power and wait for 15 minutes or more until the charge lamp turns off. Otherwise, an electric shock may occur. In addition, when confirming whether the charge lamp is off or not, always confirm it from the front of the servo amplifier.

CAUTION

- The internal circuits of the servo amplifier may be damaged by static electricity. Always take the following precautions.
 - Ground human body and work bench.
 - Do not touch the conductive areas, such as connector pins and electrical parts, directly by hand.

POINT

- Replacing a battery will erase the absolute position data.
- Before replacing batteries, check that the new battery is within battery life.

11. OPTIONS AND PERIPHERAL EQUIPMENT

(a) Assembly of the battery unit



- CAUTION**
- Do not mount new and old batteries together.
 - When you change a battery, change all batteries at the same time.

POINT

- Always mount five MR-BAT6V1 batteries to the MR-BT6VCASE battery case.

1) Things to be prepared

Product name	Model	Quantity	Remark
Battery case	MR-BT6VCASE	1	MR-BT6VCASE is a case used for connecting and mounting five MR-BAT6V1 batteries.
Battery	MR-BAT6V1	5	Lithium battery (primary battery, nominal + 6 V)

2) Disassembly and assembly of the battery case MR-BT6VCASE

a) Disassembly of the case

MR-BT6VCASE is shipped assembled. To mount MR-BAT6V1 batteries, the case needs to be disassembled.

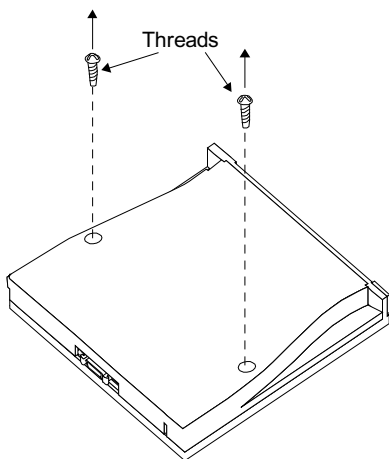

Remove the two screws using a Phillips head screwdriver.

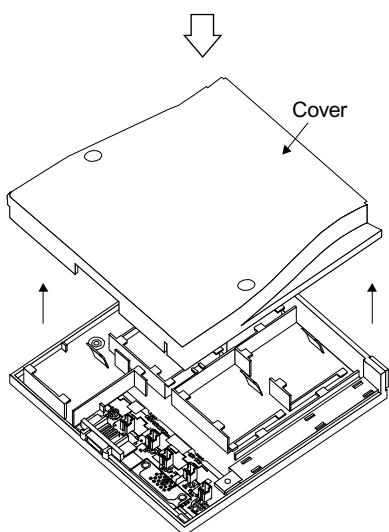

Remove the cover.

Parts identification

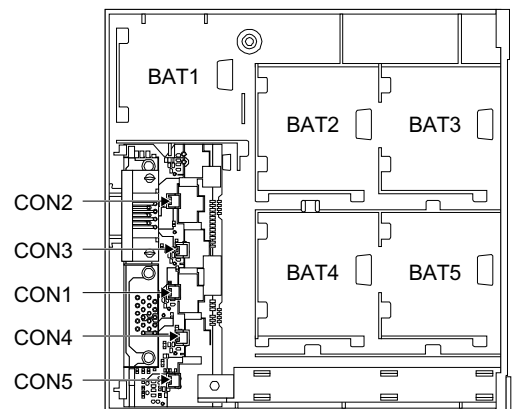

11. OPTIONS AND PERIPHERAL EQUIPMENT

b) Mounting MR-BAT6V1

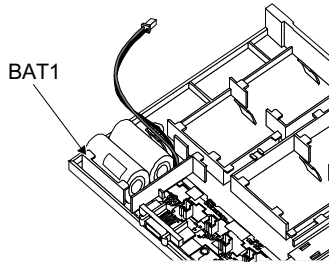

Securely mount an MR-BAT6V1 to the BAT1 holder.

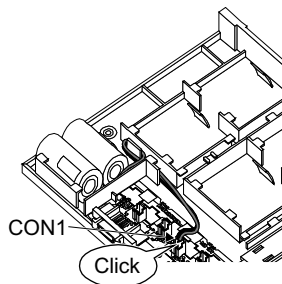

Insert the MR-BAT6V1 connector mounted on the BAT1 holder to CON1.

Confirm the click sound at this point.

The connector has to be connected in the right direction.

If the connector is pushed forcefully in the incorrect direction, the connector will break.

Place the MR-BAT6V1 lead wire to the duct designed to store lead wires.

Insert MR-BAT6V1 to the holder in the same procedure in the order from BAT2 to BAT5.

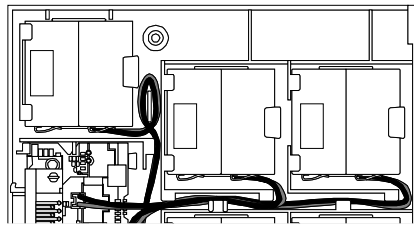
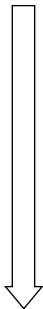

Bring out the lead wire from the space between the ribs, and bend it as shown above to store it in the duct. Connect the lead wire to the connector. Be careful not to get the lead wire caught in the case or other parts.
When the lead wire is damaged, external short circuit may occur, and the battery can become hot.

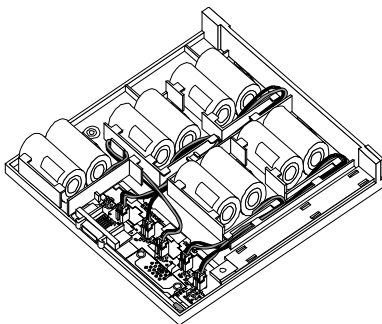

11. OPTIONS AND PERIPHERAL EQUIPMENT

c) Assembly of the case

After all MR-BAT6V1 batteries are mounted, fit the cover and insert screws into the two holes and tighten them. Tightening torque is 0.71 N·m.

POINT

- When assembling the case, be careful not to get the lead wires caught in the fitting parts or the screwing parts.

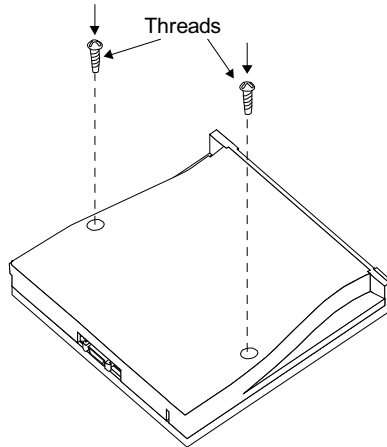

d) Precautions for removal of battery

The connector attached to the MR-BAT6V1 battery has the lock release lever. When removing the connector, pull out the connector while pressing the lock release lever.

3) Battery cable removal

CAUTION

- Pulling out the connector of the MR-BT6V1CBL and MR-BT6V2CBL without the lock release lever pressed may damage the CN4 connector of the servo amplifier or the connector of the MR-BT6V1CBL or MR-BT6V2CBL.

Pull out the connector in the same procedure as that of the MR-BAT6V1SET-A. Refer to section 11.5.2 (3) (b).

11. OPTIONS AND PERIPHERAL EQUIPMENT

11.5.4 MR-BAT6V1 battery

The MR-BAT6V1 battery is a primary lithium battery for replacing MR-BAT6V1SET-A and MR-BAT6V1SET and a primary lithium battery built-in MR-BT6VCASE. Always store the MR-BAT6V1 in a case when using it. The year and month of manufacture of the MR-BAT6V1 battery are described on the rating plate put on an MR-BAT6V1 battery.

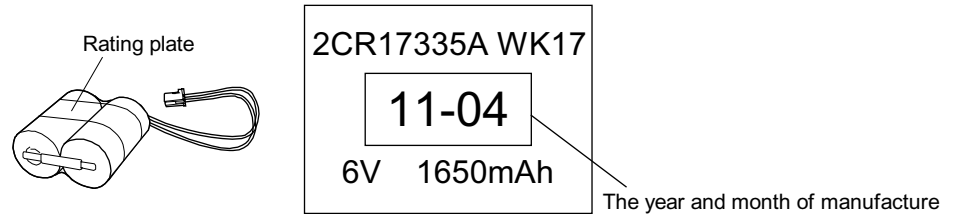

Item	Description
Battery pack	2CR17335A (CR17335A × 2 pcs. in series)
Nominal voltage [V]	6
Nominal capacity [mAh]	1650
Storage temperature [°C]	0 to 55
Operating temperature [°C]	0 to 55
Lithium content [g]	1.2
Mercury content	Less than 1 ppm
Dangerous goods class	Not subject to the dangerous goods (Class 9) Refer to app. 2 for details.
Operating humidity and storage humidity	5 %RH to 90 %RH (non-condensing)
(Note) Battery life	5 years from date of manufacture
Mass [g]	34

Note. Quality of the batteries degrades by the storage condition. The battery life is 5 years from the production date regardless of the connection status.

11. OPTIONS AND PERIPHERAL EQUIPMENT

11.6 Selection example of wires

POINT
<ul style="list-style-type: none"> ● To comply with the IEC/EN/UL/CSA standard, use the wires shown in app. 4 for wiring. To comply with other standards, use a wire that is complied with each standard. ● Selection conditions of wire size are as follows. Construction condition: Single wire set in midair Wire length: 30 m or shorter

The following diagram shows the wires used for wiring. Use the wires given in this section or equivalent.

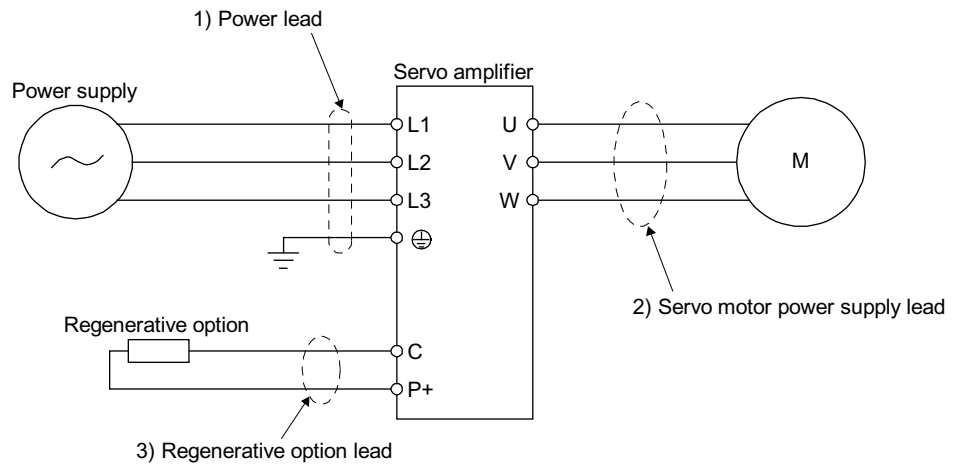

Table 11.1 shows examples for using the 600 V grade heat-resistant polyvinyl chloride insulated wire (HIV wire).

Table 11.1 Wire size selection example (HIV wire)

Servo amplifier	Wire [mm ²]		
	1) L1/L2/L3/⊕	3) P+/C	2) U/V/W/⊕ (Note 1)
MR-JE-10B	2 (AWG 14)	2 (AWG 14)	AWG 18 to 14 (Note 2)
MR-JE-20B			
MR-JE-40B			
MR-JE-70B			
MR-JE-100B			
MR-JE-200B (3-phase power supply input)	3.5 (AWG 12)	2 (AWG 14)	AWG 16 to 10
MR-JE-200B (1-phase power supply input)			
MR-JE-300B			

- Note
1. The wire size shows applicable size of the servo amplifier connector. For wires connecting to the servo motor, refer to "HG-KN_/HG-SN_ Servo Motor Instruction Manual".
 2. Be sure to use the size of 2 mm² for compliance with the IEC/EN/UL/CSA standard.

11. OPTIONS AND PERIPHERAL EQUIPMENT

11.7 Molded-case circuit breakers, fuses, magnetic contactors

CAUTION

- Select a molded-case circuit breaker with a fast shut-off time to prevent smoke or a fire.
- Always use one molded-case circuit breaker and one magnetic contactor with one servo amplifier.

When using a fuse instead of the molded-case circuit breaker, use the one having the specifications given in this section.

Servo amplifier	Molded-case circuit breaker (Note 1 and 4)			Fuse			Magnetic contactor (Note 2)	
	Frame, rated current		Voltage AC [V]	Class	Current [A]	Voltage AC [V]		
	Power factor improving reactor is not used	Power factor improving reactor is used						
MR-JE-10B	30 A frame 5 A	30 A frame 5 A	240	T	10	300	S-N10 S-T10	
MR-JE-20B								
MR-JE-40B	30 A frame 10 A	30 A frame 5 A						15
MR-JE-70B	30 A frame 15 A	30 A frame 10 A						20
MR-JE-100B (3-phase power supply input)								
MR-JE-100B (1-phase power supply input)	30 A frame 15 A	30 A frame 15 A					30	
MR-JE-200B	30 A frame 20 A	30 A frame 20 A					40	S-N20 (Note 3) S-T21
MR-JE-300B	30 A frame 30 A	30 A frame 30 A	70	S-N20 S-T21				

- Note
1. When having the servo amplifier comply with the IEC/EN/UL/CSA standard, refer to app. 4.
 2. Use a magnetic contactor with an operation delay time (interval since a current is applied to the coil until the contact closes) of 80 ms or shorter.
 3. S-N18 can be used when auxiliary contact is not required.
 4. Use a molded-case circuit breaker having the operation characteristics equal to or higher than Mitsubishi Electric general-purpose products.

The Type E Combination motor controller can also be used instead of a molded-case circuit breaker.

Servo amplifier	Rated input voltage AC [V]	Input phase	Type E Combination motor controller			SCCR [kA]
			Model	Rated voltage AC [V]	Rated current [A] (Heater design)	
MR-JE-10B	200 to 240	3-phase	MMP-T32	240	1.6	50
MR-JE-20B					2.5	
MR-JE-40B					4	
MR-JE-70B					6.3	
MR-JE-100B					8	
MR-JE-200B					18	
MR-JE-300B					25	25

11. OPTIONS AND PERIPHERAL EQUIPMENT

11.8 Power factor improving AC reactor

The following shows the advantages of using a power factor improving AC reactor.

- It improves the power factor by increasing the form factor of the servo amplifier's input current.
- It decreases the power supply capacity.
- The input power factor is improved to about 80%.

When using power factor improving reactors for two servo amplifiers or more, be sure to connect a power factor improving reactor to each servo amplifier. If using only one power factor improving reactor, enough improvement effect of phase factor cannot be obtained unless all servo amplifiers are operated.

(1) Connection example

(a) For 3-phase 200 V AC to 240 V AC power supply

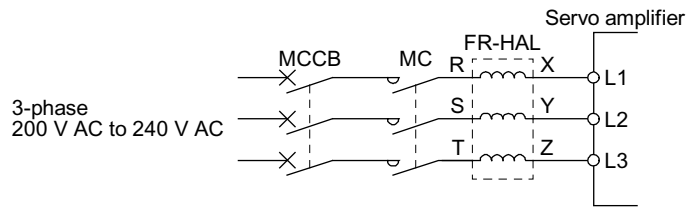

(b) For 1-phase 200 V AC to 240 V AC power supply of MR-JE-10B to MR-JE-100B

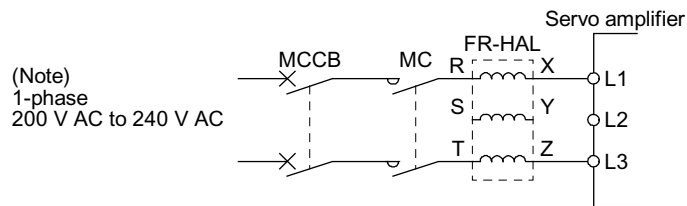

Note. Connect the power supply to L1 and L3. Leave L2 open.

(c) For 1-phase 200 V AC to 240 V AC power supply of MR-JE-200B

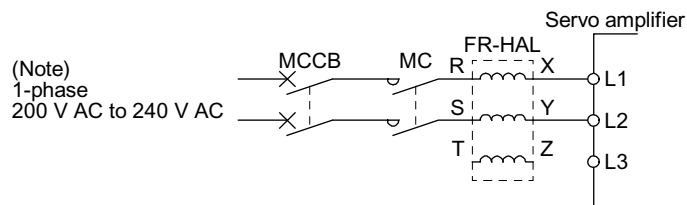

Note. Connect the power supply to L1 and L2. Leave L3 open.

11. OPTIONS AND PERIPHERAL EQUIPMENT

(2) Dimensions

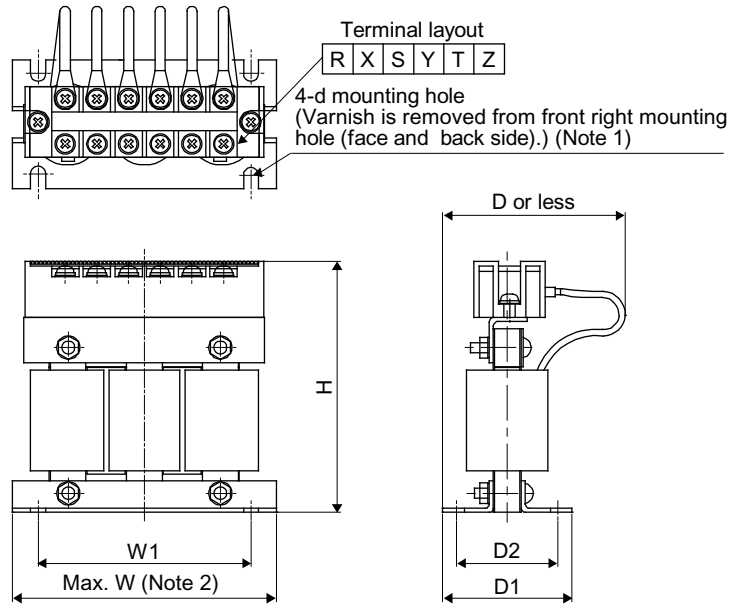

Fig. 11.1

Servo amplifier	Power factor improving AC reactor	Dimensions	Dimensions [mm]							Terminal size	Mass [kg]
			W	W1	H	D (Note 3)	D1	D2	d		
MR-JE-10B, MR-JE-20B	FR-HAL-0.4K	Fig. 11.1	104	84	99	72	51	40	M5	M4	0.6
MR-JE-40B	FR-HAL-0.75K		104	84	99	74	56	44	M5	M4	0.8
MR-JE-70B	FR-HAL-1.5K		104	84	99	77	61	50	M5	M4	1.1
MR-JE-100B (3-phase power supply input)	FR-HAL-2.2K		115 (Note 3)	40	115	77	71	57	M6	M4	1.5
MR-JE-100B (1-phase power supply input) MR-JE-200B (3-phase power supply input)	FR-HAL-3.7K		115 (Note 3)	40	115	83	81	67	M6	M4	2.2
MR-JE-200B (1-phase power supply input) MR-JE-300B	FR-HAL-5.5K		115 (Note 3)	40	115	83	81	67	M6	M4	2.3

Note 1. Use this for grounding.

2. $W \pm 2$ is applicable for FR-HAL-0.4K to FR-HAL-1.5K.

3. Maximum dimensions. The dimension varies depending on the input/output lines.

11.9 Relay (recommended)

The following relays should be used with the interfaces.

Interface	Selection example
Digital input (interface DI-1) Relay used for digital input command signals	To prevent defective contacts, use a relay for small signal (twin contacts). (Ex.) Omron: type G2A, MY
Digital output (interface DO-1) Relay used for digital output signals	Small relay with 12 V DC or 24 V DC of rated current 40 mA or less (Ex.) Omron: type MY

11. OPTIONS AND PERIPHERAL EQUIPMENT

11.10 Noise reduction techniques

Noises are classified into external noises which enter the servo amplifier to cause it to malfunction and those radiated by the servo amplifier to cause peripheral equipment to malfunction. Since the servo amplifier is an electronic device which handles small signals, the following general noise reduction techniques are required. Also, the servo amplifier can be a source of noise as its outputs are chopped by high carrier frequencies. If peripheral equipment malfunctions due to noises produced by the servo amplifier, noise suppression measures must be taken. The measures will vary slightly with the routes of noise transmission.

(1) Noise reduction techniques

(a) General reduction techniques

- Avoid laying power lines (input and output cables) and signal cables side by side or do not bundle them together. Separate power lines from signal cables.
- Use a shielded twisted pair cable for connection with the encoder and for control signal transmission, and connect the external conductor of the cable to the SD terminal.
- Ground the servo amplifier, servo motor, etc. together at one point. (Refer to section 3.11.)

(b) Reduction techniques for external noises that cause the servo amplifier to malfunction

If there are noise sources (such as a magnetic contactor, an electromagnetic brake, and many relays which make a large amount of noise) near the servo amplifier and the servo amplifier may malfunction, the following countermeasures are required.

- Provide surge killers on the noise sources to suppress noises.
- Attach data line filters to the signal cables.
- Ground the shields of the encoder connecting cable and the control signal cables with cable clamp fittings.
- Although a surge absorber is built into the servo amplifier, to protect the servo amplifier and other equipment against large exogenous noise and lightning surge, attaching a varistor to the power input section of the equipment is recommended.

(c) Techniques for noises radiated by the servo amplifier that cause peripheral equipment to malfunction

Noises produced by the servo amplifier are classified into those radiated from the cables connected to the servo amplifier and its main circuits (input and output circuits), those induced electromagnetically or statically by the signal cables of the peripheral equipment located near the main circuit cables, and those transmitted through the power supply cables.

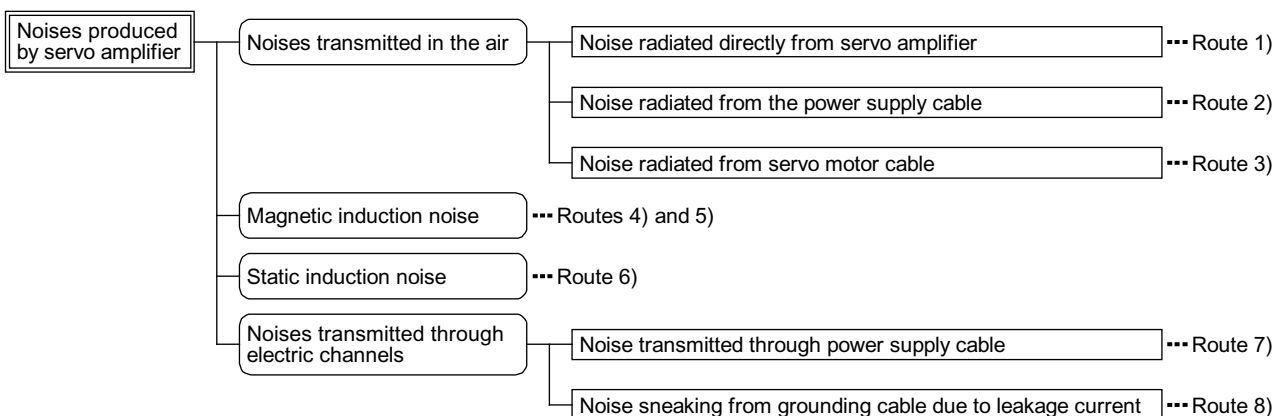

11. OPTIONS AND PERIPHERAL EQUIPMENT

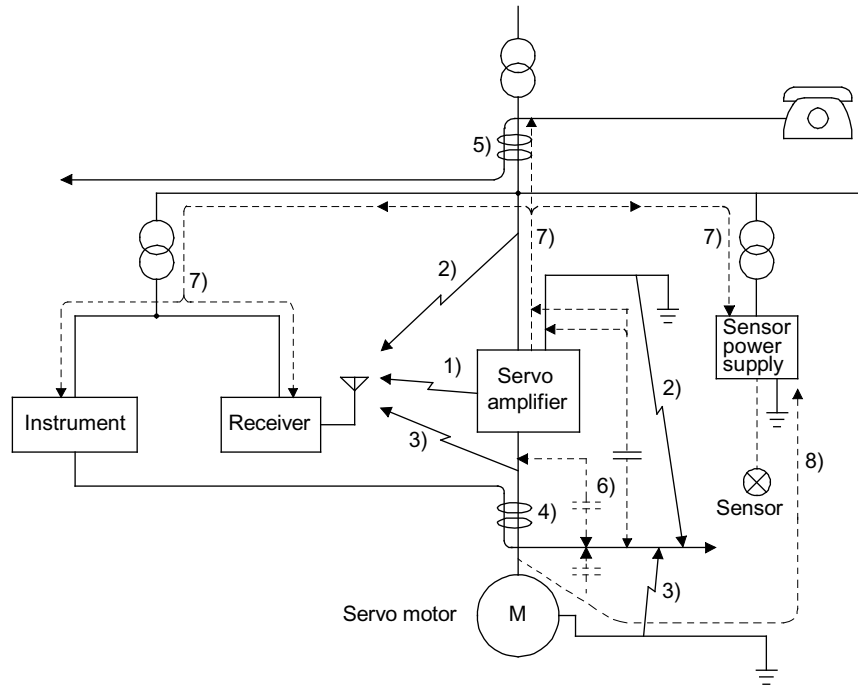

Noise transmission route	Suppression techniques
1) 2) 3)	<p>When measuring instruments, receivers, sensors, etc. which handle weak signals and may malfunction due to noise and/or their signal cables are contained in a cabinet together with the servo amplifier or run near the servo amplifier, such devices may malfunction due to noises transmitted through the air. The following techniques are required.</p> <ol style="list-style-type: none"> 1. Provide maximum clearance between easily affected devices and the servo amplifier. 2. Provide maximum clearance between easily affected signal cables and the I/O cables of the servo amplifier. 3. Avoid wiring the power lines (input/output lines of the servo amplifier) and signal lines side by side or bundling them together. 4. Insert a line noise filter to the I/O cables or a radio noise filter on the input line. 5. Use shielded wires for the signal and power lines, or put the lines in separate metal conduits.
4) 5) 6)	<p>When the power lines and the signal lines are laid side by side or bundled together, magnetic induction noise and static induction noise will be transmitted through the signal cables and malfunction may occur. The following techniques are required.</p> <ol style="list-style-type: none"> 1. Provide maximum clearance between easily affected devices and the servo amplifier. 2. Provide maximum clearance between easily affected signal cables and the I/O cables of the servo amplifier. 3. Avoid wiring the power lines (input/output lines of the servo amplifier) and signal lines side by side or bundling them together. 4. Use shielded wires for the signal and power lines, or put the lines in separate metal conduits.
7)	<p>When the power supply of peripheral equipment is connected to the power supply of the servo amplifier system, noises produced by the servo amplifier may be transmitted back through the power supply cable and the devices may malfunction. The following techniques are required.</p> <ol style="list-style-type: none"> 1. Install the radio noise filter (FR-BIF) on the power lines (Input lines) of the servo amplifier. 2. Install the line noise filter (FR-BSF01) on the power lines of the servo amplifier.
8)	<p>If the grounding wires of the peripheral equipment and the servo amplifier make a closed loop circuit, leakage current may flow through, causing the equipment to malfunction. In this case, the malfunction may be prevented by the grounding wires disconnected from the equipment.</p>

11. OPTIONS AND PERIPHERAL EQUIPMENT

(2) Noise reduction products

(a) Data line filter (recommended)

Noise can be prevented by installing a data line filter onto the encoder cable, etc.

For example, ZCAT3035-1330 by TDK, ESD-SR-250 by TOKIN, GRFC-13 by Kitagawa Industries, and E04SRM563218 by SEIWA ELECTRIC are available as data line filters.

As a reference example, the impedance specifications of the ZCAT3035-1330 (TDK) are indicated below. These impedances are reference values and not guaranteed values.

Impedance [Ω]	
10 MHz to 100 MHz	100 MHz to 500 MHz
80	150

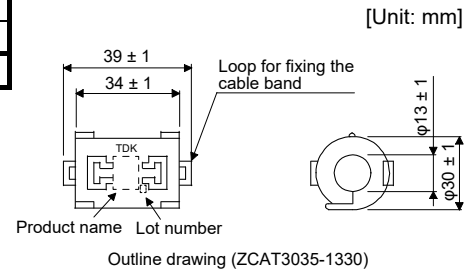

(b) Surge killer (recommended)

Use of a surge killer is recommended for AC relay, magnetic contactor or the like near the servo amplifier. Use the following surge killer or equivalent.

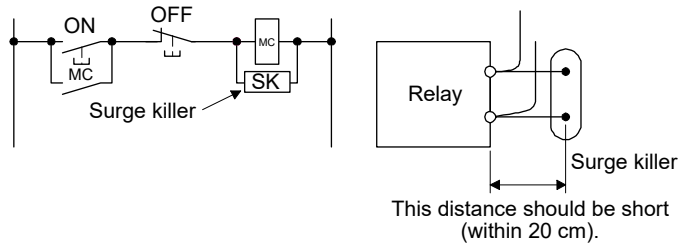

(Ex.) CR-50500 Okaya Electric Industries)

Rated voltage AC [V]	C [$\mu\text{F} \pm 20\%$]	R [$\Omega \pm 30\%$]	Test voltage
250	0.5	50 (1/2 W)	Between terminals: 625 V AC, 50 Hz/60 Hz 60 s Between terminal and case: 2000 V AC, 50 Hz/60 Hz 60 s

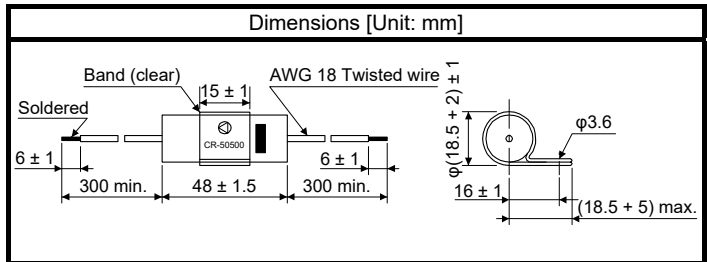

Note that a diode should be installed to a DC relay or the like.

Maximum voltage: Not less than 4 times the drive voltage of the relay or the like

Maximum current: Not less than twice the drive current of the relay or the like

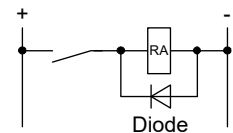

11. OPTIONS AND PERIPHERAL EQUIPMENT

(c) Cable clamp fitting AERSBAN-_SET

Generally, connecting the grounding of the shielded wire to the SD terminal of the connector provides a sufficient effect. However, the effect can be increased when the shielded wire is connected directly to the grounding plate as shown below.

Install the grounding plate near the servo amplifier for the encoder cable. Peel part of the cable sheath to expose the external conductor, and press that part against the grounding plate with the cable clamp.

If the cable is thin, clamp several cables in a bunch. The cable clamp comes as a set with the grounding plate.

[Unit: mm]

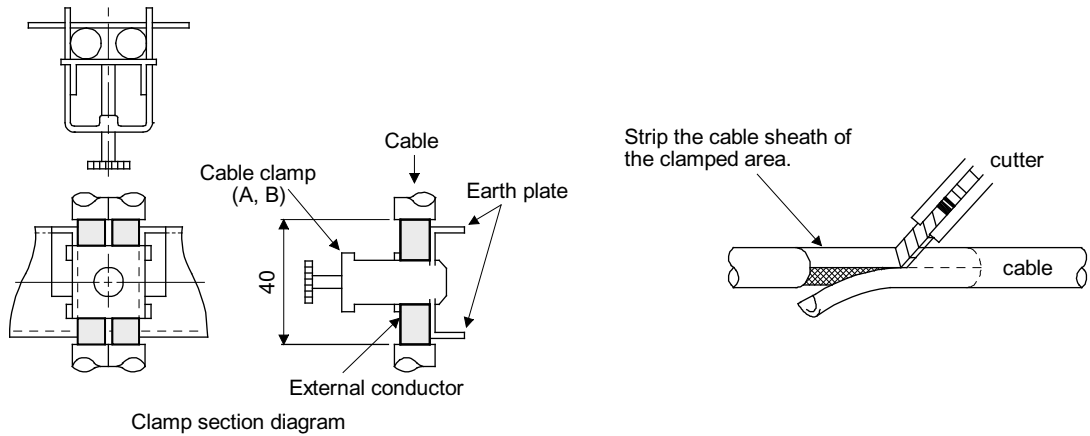

• Dimensions

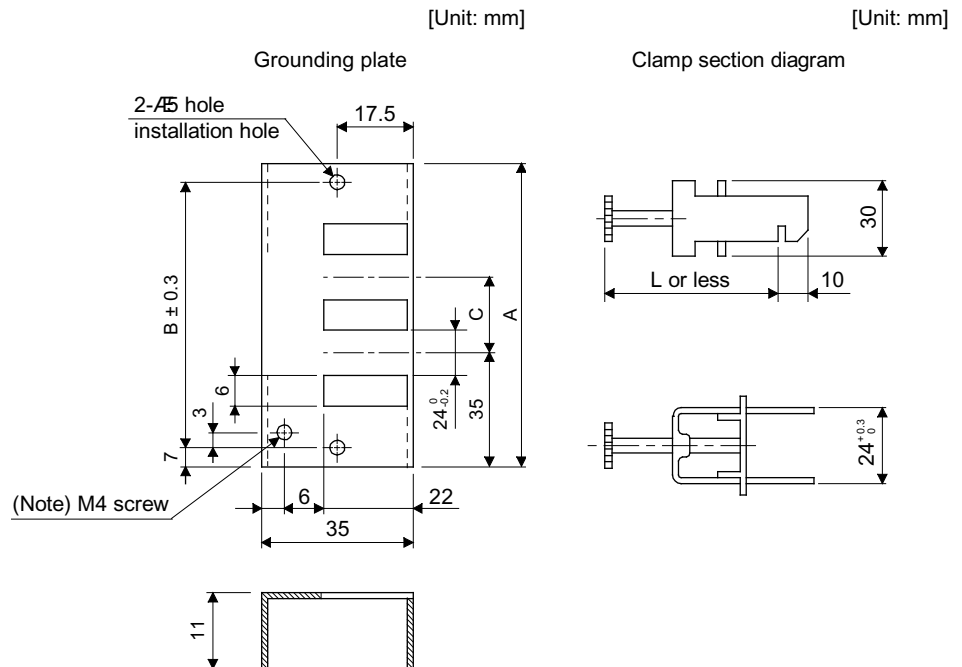

Note. Screw hole for grounding. Connect it to the grounding plate of the cabinet.

Model	A	B	C	Accessory fittings
AERSBAN-DSET	100	86	30	Clamp A: 2 pcs.
AERSBAN-ESET	70	56		Clamp B: 1 pc.

Clamp fitting	L
A	70
B	45

11. OPTIONS AND PERIPHERAL EQUIPMENT

(d) Line noise filter (FR-BSF01)

This filter is effective in suppressing noises radiated from the power supply side and output side of the servo amplifier and also in suppressing high-frequency leakage current (0-phase current). It especially affects the noises between 0.5 MHz and 5 MHz band.

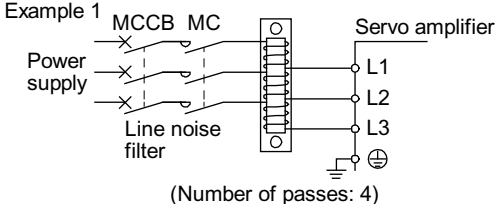
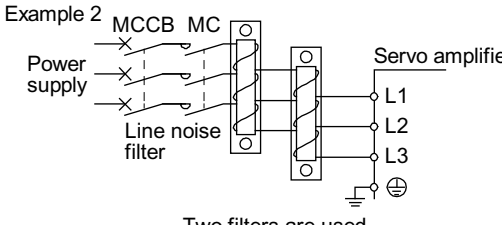
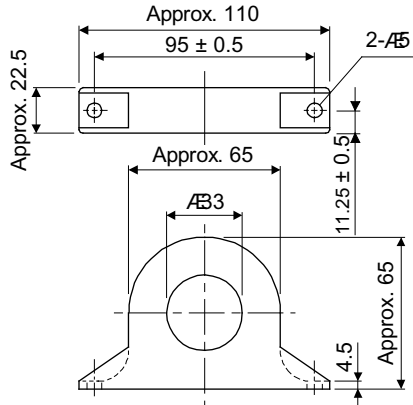
Connection diagram	Dimensions [Unit: mm]
<p>The line noise filters can be installed on lines of the power supply (L1/L2/L3) and of the servo motor power (U/V/W). Pass each of the wires through the line noise filter an equal number of times in the same direction. For wires of the power supply, the effect of the filter rises as the number of passes increases, but generally four passes would be appropriate. For the servo motor power lines, passes must be four times or less. Do not pass the grounding wire through the filter. Otherwise, the effect of the filter will drop.</p> <p>Wind the wires by passing through the filter to satisfy the required number of passes as shown in Example 1. If the wires are too thick to wind, use two or more filters to have the required number of passes as shown in Example 2.</p> <p>Place the line noise filters as close to the servo amplifier as possible for their best performance.</p> <p>Example 1</p>  <p>(Number of passes: 4)</p> <p>Example 2</p>  <p>Two filters are used (Total number of passes: 4)</p>	<p>FR-BSF01 (for wire size 3.5 mm² (AWG 12) or smaller)</p> 

11. OPTIONS AND PERIPHERAL EQUIPMENT

(e) Radio noise filter (FR-BIF)

This filter is effective in suppressing noises radiated from the power supply side of the servo amplifier especially in 10 MHz and lower radio frequency bands. The FR-BIF is designed for the input only.

200 V class: FR-BIF

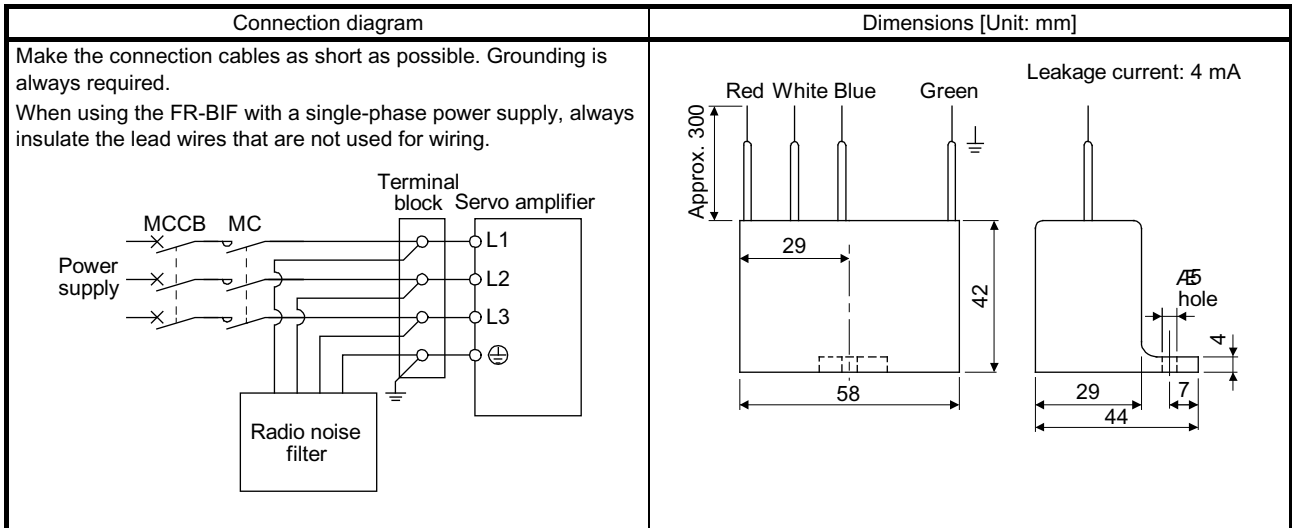

(f) Varistor for input power supply (recommended)

Varistors are effective to prevent exogenous noise and lightning surge from entering the servo amplifier. When using a varistor, connect it between each phase of the input power supply of the equipment. For varistors, the TND20V-431K and TND20V-471K, manufactured by Nippon Chemi-Con, are recommended. For detailed specification and usage of the varistors, refer to the manufacturer catalog.

Power supply voltage	Varistor	Maximum rating					Maximum limit voltage		Static capacity (reference value)	Varistor voltage rating (range) V1 mA
		Permissible circuit voltage		Surge current immunity	Energy immunity	Rated pulse power	[A]	[V]		
		AC [Vrms]	DC [V]	8/20 μ s [A]	2 ms [J]	[W]			[pF]	[V]
200 V class	TND20V-431K	275	350	10000/1 time	195	1.0	100	710	1300	430 (387 to 473)
	TND20V-471K	300	385	7000/2 times	215			775	1200	470 (423 to 517)

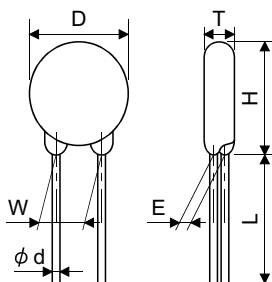

[Unit: mm]

Model	D Max.	H Max.	T Max.	E \pm 1.0	(Note) L Min.	Δ \pm 0.05	W \pm 1.0
TND20V-431K	21.5	24.5	6.4	3.3	20	0.8	10.0
TND20V-471K			6.6	3.5			

Note. For special purpose items for lead length (L), contact the manufacturer.

11. OPTIONS AND PERIPHERAL EQUIPMENT

11.11 Earth-leakage current breaker

(1) Selection method

High-frequency chopper currents controlled by pulse width modulation flow in the AC servo circuits. Leakage currents containing harmonic contents are larger than those of the motor which is run with a commercial power supply.

Select an earth-leakage current breaker according to the following formula, and ground the servo amplifier, servo motor, etc. securely.

To minimize leakage currents, make the input and output wires as short as possible, and keep a distance of 30 cm or longer between the wires and ground.

$$\text{Rated sensitivity current} \geq 10 \times \{I_{g1} + I_{gn} + I_{ga} + K \times (I_{g2} + I_{gm})\} \text{ [mA]} \dots\dots\dots (11.1)$$

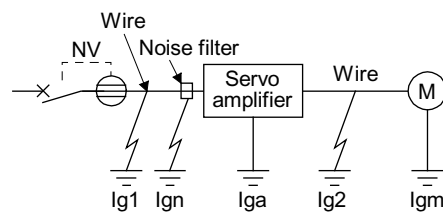

Earth-leakage current breaker		K
Type	Mitsubishi Electric products	
Models provided with harmonic and surge reduction techniques	NV-SP NV-SW NV-CP NV-CW NV-HW	1
General models	BV-C1 NFB NV-L	3

Ig1: Leakage current on the electric channel from the earth-leakage current breaker to the input terminals of the servo amplifier (Found from Fig. 11.2.)

Ig2: Leakage current on the electric channel from the output terminals of the servo amplifier to the servo motor (Found from Fig. 11.2.)

Ign: Leakage current when a filter is connected to the input side (4.4 mA per one FR-BIF)

Iga: Leakage current of the servo amplifier (Found from table 11.3.)

Igm: Leakage current of the servo motor (Found from table 11.2.)

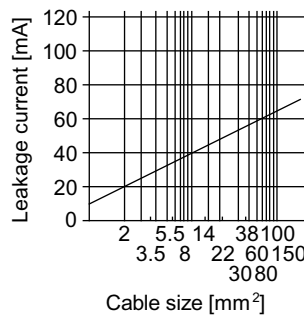

Fig. 11.2 Example of leakage current per km (Ig1, Ig2) for CV cable run in metal conduit

11. OPTIONS AND PERIPHERAL EQUIPMENT

Table 11.2 Servo motor leakage current example (Igm)

Servo motor power [kW]	Leakage current [mA]
0.1 to 1	0.1
1.5 to 2	0.2
3	0.3

Table 11.3 Servo amplifier leakage current example (Iga)

Servo amplifier capacity [kW]	Leakage current [mA]
0.1 to 0.4	0.1
0.75 to 3	0.15

Table 11.4 Earth-leakage current breaker selection example

Servo amplifier capacity [kW]	Rated sensitivity current of earth-leakage current breaker [mA]
MR-JE-10B to MR-JE-300B	15

(2) Selection example

Indicated below is an example of selecting an earth-leakage current breaker under the following conditions.

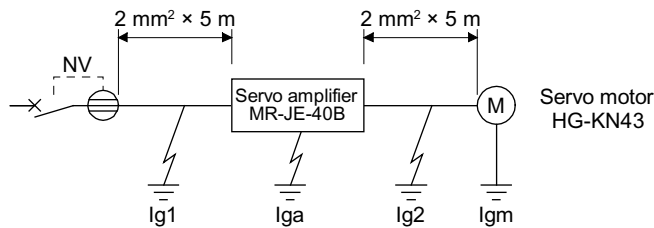

Use an earth-leakage current breaker designed for suppressing harmonics/surges. Find the terms of equation (11.1) from the diagram.

$$I_{g1} = 20 \cdot \frac{5}{1000} = 0.1 \text{ [mA]}$$

$$I_{g2} = 20 \cdot \frac{5}{1000} = 0.1 \text{ [mA]}$$

$$I_{gn} = 0 \text{ (not used)}$$

$$I_{ga} = 0.1 \text{ [mA]}$$

$$I_{gm} = 0.1 \text{ [mA]}$$

Insert these values in equation (11.1).

$$I_{ge} = 10^{-4} \{0.1 + 0 + 0.1 + 1 \cdot (0.1 + 0.1)\} = 4 \text{ [mA]}$$

According to the result of calculation, use an earth-leakage current breaker having the rated sensitivity current (I_g) of 4.0 mA or more.

An earth-leakage current breaker having I_g of 15 mA is used with the NV-SP/SW/CP/CW/HW series.

11. OPTIONS AND PERIPHERAL EQUIPMENT

11.12 EMC filter (recommended)

POINT
<p>● For when multiple servo amplifiers are connected to one EMC filter, refer to section 6.4 of "EMC Installation Guidelines".</p>

It is recommended that one of the following filters be used to comply with EN EMC directive. Some EMC filters have large in leakage current.

(1) Combination with the servo amplifier

Servo amplifier	Recommended filter (Soshin Electric)				Mass [kg]
	Model	Rated current [A]	Rated voltage [V AC]	Leakage current [mA]	
MR-JE-10B to MR-JE-100B	HF3010A-UN (Note)	10	250	5	3.5
MR-JE-200B, MR-JE-300B	HF3030A-UN (Note)	30			5.5

Note. A surge protector is separately required to use any of these EMC filters.

(2) Connection example

(a) For 3-phase 200 V AC to 240 V AC power supply

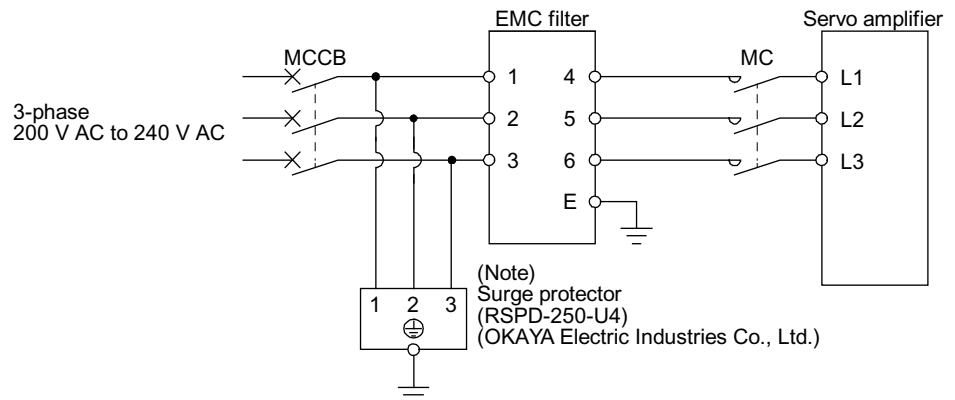

Note. The example is when a surge protector is connected.

11. OPTIONS AND PERIPHERAL EQUIPMENT

(b) For 1-phase 200 V AC to 240 V AC power supply of MR-JE-10B to MR-JE-100B

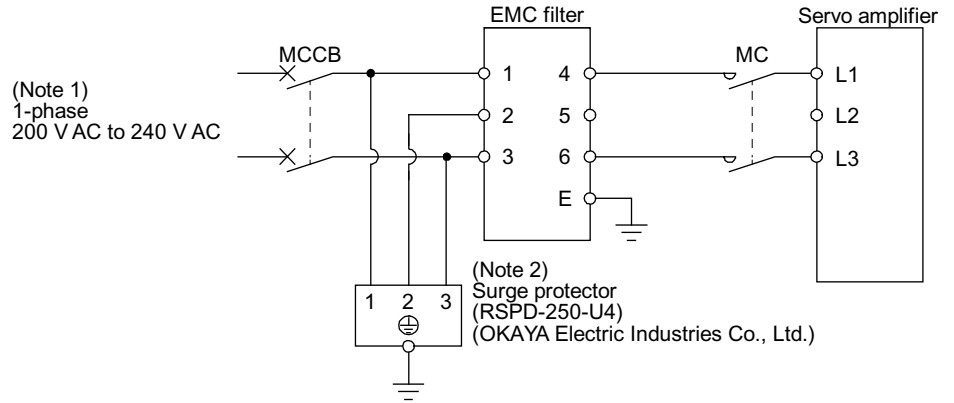

- Note 1. Connect the power supply to L1 and L3. Leave L2 open.
2. The example is when a surge protector is connected.

(c) For 1-phase 200 V AC to 240 V AC power supply of MR-JE-200B

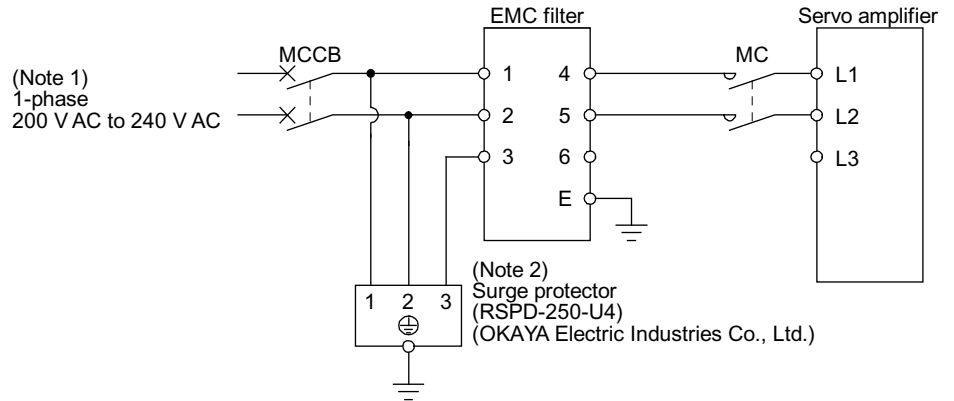

- Note 1. Connect the power supply to L1 and L2. Leave L3 open.
2. The example is when a surge protector is connected.

11. OPTIONS AND PERIPHERAL EQUIPMENT

- (3) Dimensions
 - (a) EMC filter
 - HF3010A-UN

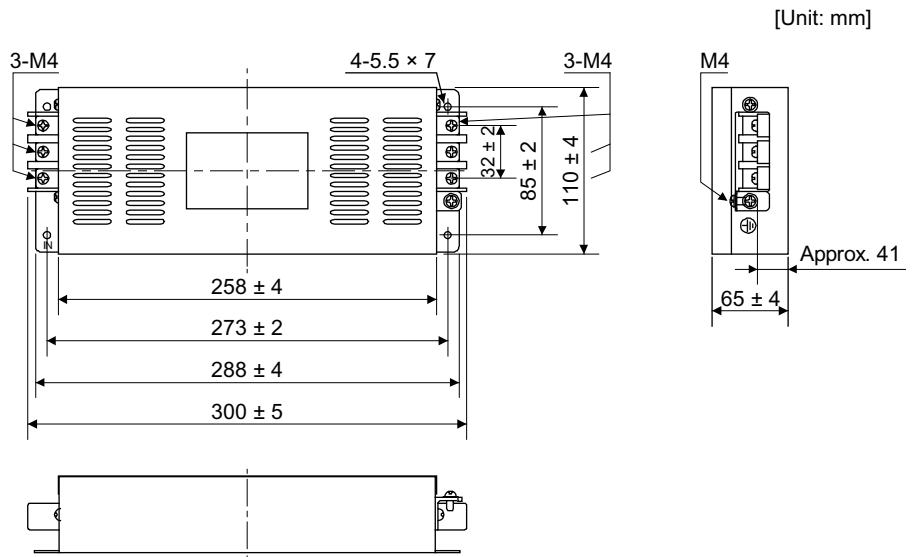

HF3030A-UN

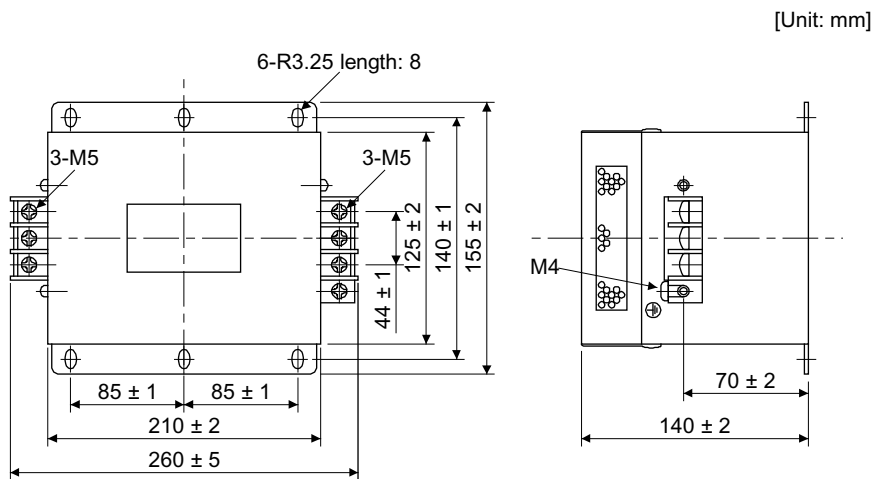

11. OPTIONS AND PERIPHERAL EQUIPMENT

(b) Surge protector

RSPD-250-U4

[Unit: mm]

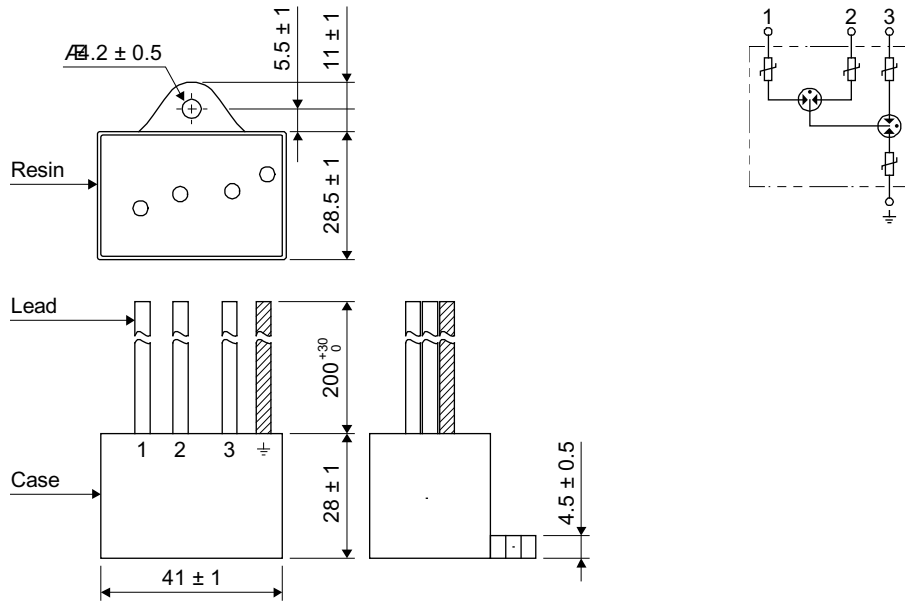

12. ABSOLUTE POSITION DETECTION SYSTEM

12. ABSOLUTE POSITION DETECTION SYSTEM

CAUTION

- If [AL. 25 Absolute position erased] or [AL. E3 Absolute position counter warning] has occurred, always perform home position setting again. Otherwise, it may cause an unexpected operation.
- If [AL. 25], [AL. 92], or [AL. 9F] occurs due to a failure, such as short circuit of the battery, the MR-BAT6V1 battery can become hot. Use the MR-BAT6V1 battery with a case to prevent getting burnt.

POINT

- Replacing a battery will erase the absolute position data.
- Refer to section 11.5 for the replacement procedure of the battery.
- When absolute position data is erased from the encoder, always execute home position setting before operation.

12.1 Summary

12.1.1 Features

For normal operation, the encoder consists of a detector designed to detect a position within one revolution and a cumulative revolution counter designed to detect the number of revolutions.

The absolute position detection system always detects the absolute position of the machine and keeps it battery-backed, independently of whether the servo system controller power is on or off. Therefore, once home position return is made at the time of machine installation, home position return is not needed when power is switched on thereafter.

Even at a power failure or a malfunction, the system can be easily restored.

12. ABSOLUTE POSITION DETECTION SYSTEM

12.1.2 Configuration

The following shows a configuration of the absolute position detection system. Refer to section 11.5 for the connection of the battery.

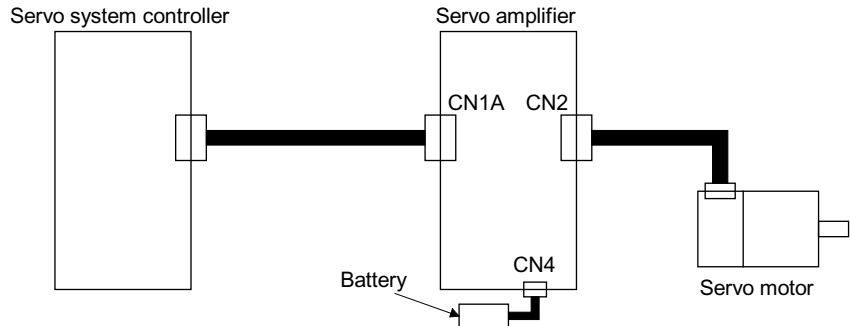

12.1.3 Parameter setting

Set "_ _ _ 1" in [Pr. PA03] to enable the absolute position detection system.

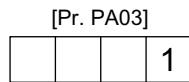

Absolute position detection system selection
0: Disabled (used in incremental system)
1: Enabled (used in absolute position detection system)

12.1.4 Confirmation of absolute position detection data

You can check the absolute position data with MR Configurator2. Choose "Monitor" and "ABS Data Display" to open the absolute position data display screen.

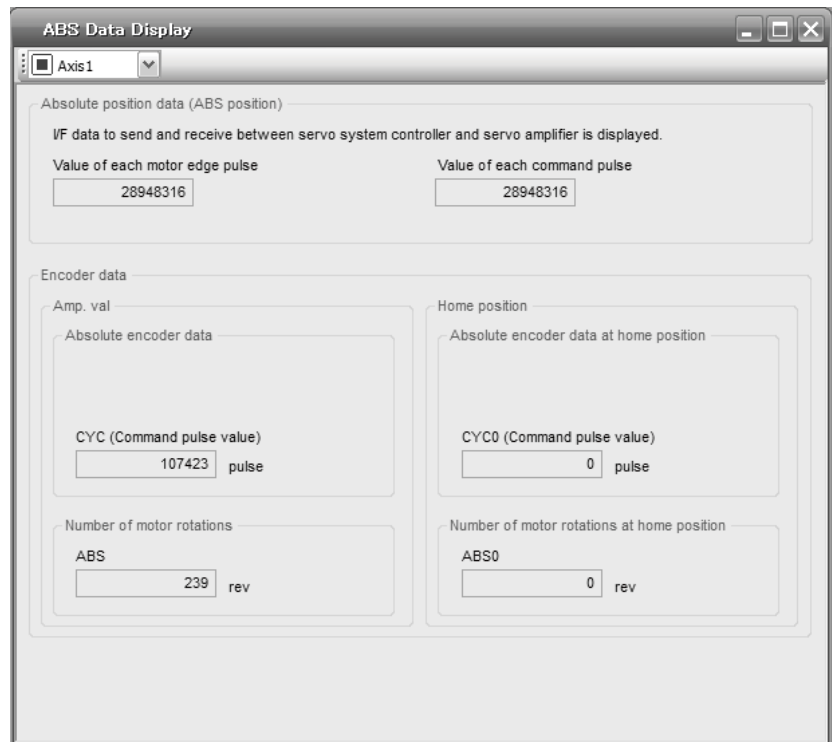

12. ABSOLUTE POSITION DETECTION SYSTEM

12.2 Battery

12.2.1 Using the MR-BAT6V1SET-A battery

(1) Configuration diagram

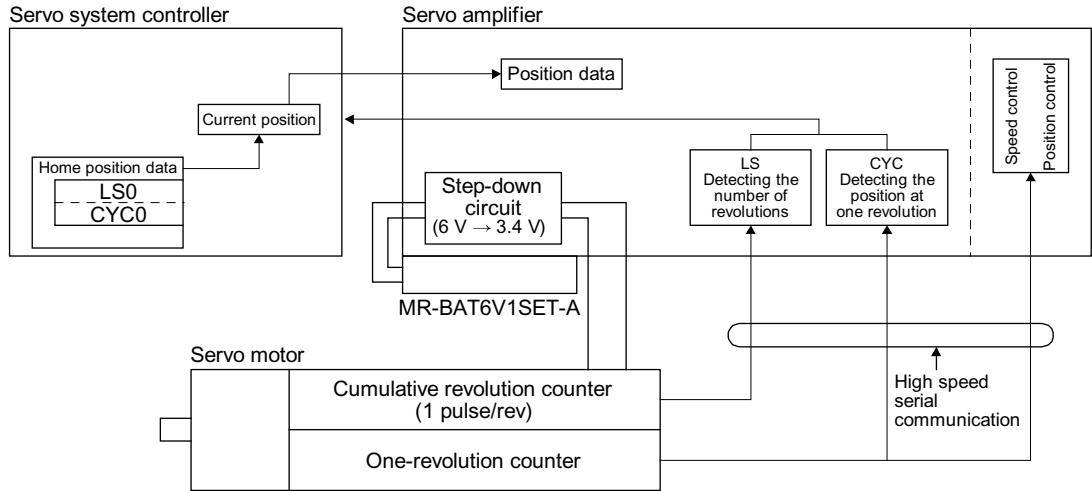

(2) Specifications

(a) Specification list

Item	Description
System	Electronic battery backup type
Maximum revolution range	Home position ± 32767 rev.
(Note 1)	6000
Maximum speed at power failure [r/min]	(only when acceleration time until 6000 r/min is 0.2 s or longer)
(Note 2)	Approximately 20,000 hours
Battery backup time	(equipment power supply: off, ambient temperature: 20 °C) Approximately 29,000 hours (power-on time ratio: 25%, ambient temperature: 20 °C) (Note 3)

- Note 1. Maximum speed available when the shaft is rotated by external force at the time of power failure or the like. Also, if power is switched on at the servo motor speed of 3000 r/min or higher, position mismatch may occur due to external force or the like.
- Note 2. The data-holding time by the battery using MR-BAT6V1SET-A. Replace the batteries within three years since the operation start regardless of the power supply of the servo amplifier on/off. If the battery is used out of specification, [AL. 25 Absolute position erased] may occur.
- Note 3. The power-on time ratio 25% is equivalent to 8 hours power on for a weekday and off for a weekend.

12. ABSOLUTE POSITION DETECTION SYSTEM

12.2.2 Using the MR-BT6VCASE battery case

POINT
<ul style="list-style-type: none"> ● One MR-BT6VCASE can hold the absolute position data of up to 8-axis servo motors. ● Always install five MR-BAT6V1 batteries to MR-BT6VCASE.

(1) Configuration diagram

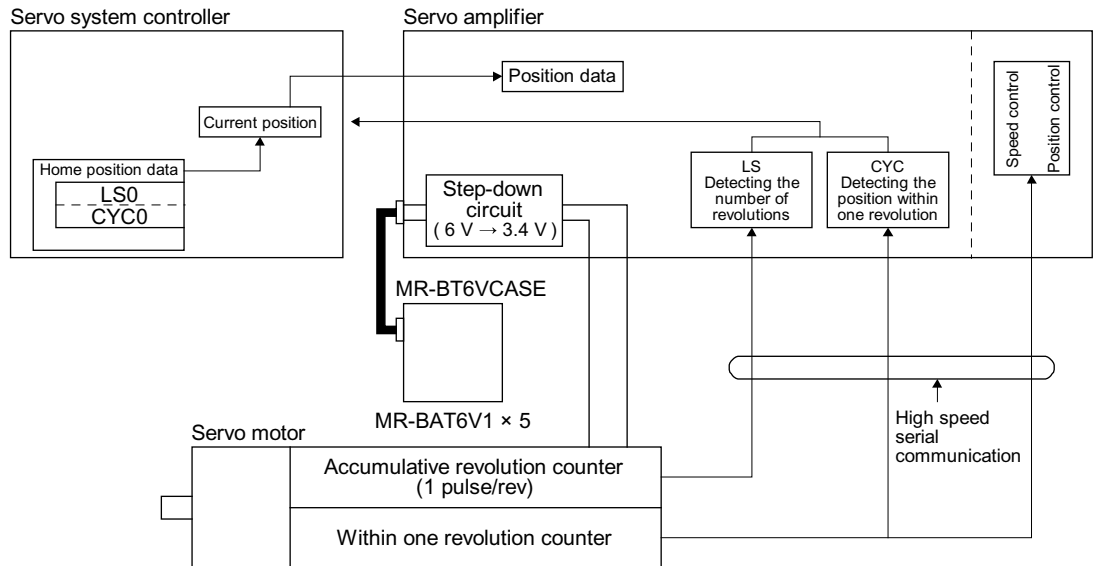

(2) Specification list

Item	Description
System	Electronic battery backup type
Maximum revolution range	Home position ± 32767 rev.
(Note 1)	6000
Maximum speed at power failure [r/min]	(only when acceleration time until 6000 r/min is 0.2 s or longer)
(Note 2)	Approximately 40,000 hours/2 axes or less, 30,000 hours/3 axes, or 10,000 hours/8 axes (equipment power supply: off, ambient temperature: 20 °C)
Battery backup time	Approximately 55,000 hours/2 axes or less, 38,000 hours/3 axes, or 15,000 hours/8 axes (power-on time ratio: 25%, ambient temperature: 20 °C) (Note 3)

- Note 1. Maximum speed available when the shaft is rotated by external force at the time of power failure or the like. Also, if power is switched on at the servo motor speed of 3000 r/min or higher, position mismatch may occur due to external force or the like.
- Note 2. The data-holding time by five MR-BAT6V1 batteries. The battery life varies depending on the number of target axes (including axis for using in the incremental system). Replace the batteries within three years since the operation start regardless of the power supply of the servo amplifier on/off. If the battery is used out of specification, [AL. 25 Absolute position erased] may occur.
- Note 3. The power-on time ratio 25% is equivalent to 8 hours power on for a weekday and off for a weekend.

APPENDIX

APPENDIX

App. 1 Peripheral equipment manufacturer (for reference)

Names given in the table are as of November 2023.

For information, such as the delivery time, price, and specifications of the recommended products, contact each manufacturer.

Manufacturer	Contact information
TOKIN	TOKIN Corporation
Kitagawa Industries	Kitagawa Industries Co., Ltd.
JST	J.S.T. Mfg. Co., Ltd.
Junkosha	Toa Electric Industrial Co. Ltd., Nagoya Branch
3M	3M
SEIWA ELECTRIC	Seiwa Electric Mfg. Co. Ltd.
Soshin Electric	Soshin Electric Co., Ltd.
TDK	TDK Corporation
Molex	Molex Japan LLC
Toho Technology	Toho Technology Corp., Kyoto factory

App. 2 Handling of AC servo amplifier batteries for the United Nations Recommendations on the Transport of Dangerous Goods

United Nations Recommendations on the Transport of Dangerous Goods Rev. 15 (hereinafter Recommendations of the United Nations) has been issued. To reflect this, transport regulations for lithium metal batteries are partially revised in the Technical Instruction (ICAO-TI) by the International Civil Aviation Organization (ICAO) and the International Maritime Dangerous Goods Code (IMDG Code) by the International Maritime Organization (IMO).

To comply the instruction and code, we have modified the indication on the package for general-purpose AC servo batteries.

The above change will not affect the function and performance of the product.

(1) Target model

(a) Battery (cell)

Model	Option model	Type	Lithium content	Mass of battery	Remark
ER6	MR-J3BAT	Cell	0.65 g	16 g	Cells with more than 0.3 grams of lithium content must be handled as dangerous goods (Class 9) depending on packaging requirements.
ER17330	MR-BAT	Cell	0.48 g	13 g	
	A6BAT	Cell	0.48 g	13 g	

APPENDIX

(b) Battery unit (assembled battery)

Model	Option model	Type	Lithium content	Mass of battery	Remark
ER6	MR-J2M-BT	Assembled battery (Seven)	4.55 g	112 g	Assembled batteries with more than two grams of lithium content must be handled as dangerous goods (Class 9) regardless of packaging requirements.
CR17335A	MR-BAT6V1	Assembled battery (Two)	1.20 g	34 g	Assembled batteries with more than 0.3 grams of lithium content must be handled as dangerous goods (Class 9) depending on packaging requirements.
	MR-BAT6V1SET(-A)	Assembled battery (Two)	1.20 g	34 g	
	MR-BAT6V1BJ	Assembled battery (Two)	1.20 g	34 g	

(2) Purpose

Safer transportation of lithium metal batteries.

(3) Change in regulations

The following points are changed for lithium metal batteries in transportation by sea or air based on the revision of Recommendations of the United Nations Rev. 15 and ICAO-TI 2009-2010 edition, and IATA Dangerous Goods Regulations 54th Edition (effective January 1, 2013). For lithium metal batteries, cells are classified as UN3090, and batteries contained in or packed with equipment are classified as UN3091.

(a) Transportation of lithium metal batteries alone

Packaging requirement	Classification	Main requirement
Less than eight cells per package with less than one gram of lithium content	UN3090 P1968 Section II	The package must pass a 1.2 m drop test, and the handling label with battery illustration (size: 120 × 110 mm) must be attached on the package.
Less than two assembled batteries per package with less than two grams of lithium content		
More than eight cells per package with less than one gram of lithium content	UN3090 P1968 Section IB	The package must pass a 1.2 m drop test, and the handling label with battery illustration (size: 120 × 110 mm) must be attached on the package. The Class 9 hazard label must be attached or others to comply with dangerous goods (Class 9).
More than two assembled batteries per package with less than two grams of lithium content		
Cells with more than one gram of lithium content	UN3090 P1968 Section IA	The package must be compliant with Class 9 Packages, and the Class 9 hazard label must be attached or others to comply with dangerous goods (Class 9).
Assembled batteries with more than two grams of lithium content		

APPENDIX

(b) Transportation of lithium metal batteries packed with or contained in equipment

- 1) For batteries packed with equipment, follow the necessary requirements of UN3091 PI969. Batteries are classified into either Section II/Section I depending on the lithium content/packaging requirements.
- 2) For batteries contained in equipment, follow the necessary requirements of UN3091 PI970. Batteries are classified into either Section II/Section I depending on the lithium content/packaging requirements.
The special handling may be unnecessary depending on the number of batteries and gross mass per package.



Fig. app. 1 Example of Mitsubishi label with battery illustration

(Available until December 31, 2018)

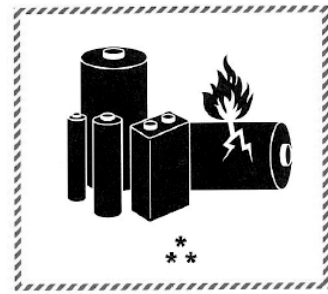

* Place for UN number (s)
** Place for telephone number for additional information

Fig. app. 2 Example of Mitsubishi label with battery illustration

(Available from January 1, 2017)

The handling label shown in Fig. app. 1 has been changed to the one shown in Fig. app. 2 in accordance with the IATA Dangerous Goods Regulations 58th Edition (effective January 1, 2017). However, the label shown in Fig. app. 1 may be used until December 31, 2018 (for two years as an interim measure).

(4) Details of the package change

The following caution is added to the packages of the target batteries.
"Containing lithium metal battery. Regulations apply for transportation."

(5) Transportation precaution for customers

For sea or air transportation, attaching the handling label (fig. app. 1) must be attached to the package of a Mitsubishi Electric cell or battery. In addition, attaching it to the outer package containing several packages of Mitsubishi Electric cells or batteries is also required. When the content of a package must be handled as dangerous goods (Class 9), the Shipper's Declaration for Dangerous Goods is required, and the package must be compliant with Class 9 Packages. Documentations like the handling label in the specified design and the Shipper's Declaration for Dangerous Goods are required for transportation. Please attach the documentations to the packages and the outer package.

The IATA Dangerous Goods Regulations are revised, and the requirements are changed annually. When customers transport lithium batteries by themselves, the responsibility for the cargo lies with the customers. Thus, be sure to check the latest version of the IATA Dangerous Goods Regulations.

APPENDIX

App. 3 Symbol for the new EU Battery Directive

Symbol for the new EU Battery Directive (2006/66/EC) that is plastered to general-purpose AC servo battery is explained here.



Note. This symbol mark is for EU countries only.

This symbol mark is according to the directive 2006/66/EC Article 20 Information for end-users and Annex II. Your MITSUBISHI ELECTRIC product is designed and manufactured with high quality materials and components which can be recycled and/or reused.

This symbol means that batteries and accumulators, at their end-of-life, should be disposed of separately from your household waste.

If a chemical symbol is printed beneath the symbol shown above, this chemical symbol means that the battery or accumulator contains a heavy metal at a certain concentration.

This will be indicated as follows.

Hg: mercury (0.0005%), Cd: cadmium (0.002%), Pb: lead (0.004%)

In the European Union there are separate collection systems for used batteries and accumulators. Please, dispose of batteries and accumulators correctly at your local community waste collection/recycling center.

Please, help us to conserve the environment we live in!

APPENDIX

App. 4 Compliance with global standards

For compliance with the standards of Europe/UK, United States/Canada, and South Korea, refer to the following manual.

MR-JE Instructions and Cautions for Safe Use of AC Servos (IB(NA)-0300194ENG)

App. 5 SSCNET III cable (SC-J3BUS_M-C) manufactured by Mitsubishi Electric System & Service

POINT
● For the details of the SSCNET III cables, contact your local sales office.
● Do not look directly at the light generated from the CN1A connector and CN1B connector of servo amplifier or the end of SSCNET III cable. The light can be a discomfort when it enters the eye.





The cable is available per 1 m up to 100 m. The number of the length (1 to 100) will be in the underscore in the cable model.

Cable model	Cable length	Bending life	Application and remark
	1 m to 100 m		
SC-J3BUS_M-C	1 to 100	Ultra-long bending life	Using long distance cable

APPENDIX

App. 6 Low-voltage directive

MR-JE series servo amplifiers are certificated in compliance with Low-voltage directive. The following shows a certificate by the Certification Body.

Zertifikat		Certificate			
Zertifikat Nr. Certificate No.	R 50244051	Blatt Page	0001		
Ihr Zeichen Client Reference	T.E.	Unser Zeichen Our Reference	ZO-HIM- 12311510 001	Ausstellungsdatum Date of Issue	11.01.2013 (day/mo/yr)
Genehmigungsinhaber License Holder			Fertigungsstätte Manufacturing Plant		
Mitsubishi Electric Corp. Nagoya Works 1-14, Yada-minami 5-chome Higashi-ku, Nagoya-shi, Aichi 461-8670 JAPAN			Mitsubishi Electric Corp. Nagoya Works 1-14, Yada-minami 5-chome Higashi-ku, Nagoya-shi, Aichi 461-8670 JAPAN		
Prüfzeichen Test Mark		Geprüft nach Tested acc. to			
		EN 61800-5-1:2007 IEC 61800-5-1:2007			
Zertifiziertes Produkt (Geräteidentifikation)	(Product Identification)		Lizenzentgelte - Einheit License Fee - Unit		
Control Unit Servo Drive Unit					
Type Designation	: MR-JE-uvw-xyz				5
		u, v, w, x, y, z = (see Appendix 1)			6
Rated Voltage	: 3AC 200-240V, 50/60Hz or AC 200-240V, 50/60Hz				
Rated Current	: (see Appendix 1)				
Protection Class	: I				
Rated Output Values	: 3AC 170V 360Hz				
Ambient Temperature	: 0°C to 55°C				
Overvoltage Category	: III (3AC200-240V) or II (AC200-240V)				
Pollution Degree	: 2				
Remark: Power circuits and secondary control circuits provide protective separation. The unit must be installed in accordance with the manufacturer's instructions.					
				11	
ANLAGE (Appendix): 1					
<small>Dem Zertifikat liegt unsere Prüf- und Zertifizierungsordnung zugrunde und es bestätigt die Konformität des Produktes mit den oben genannten Standards und Prüfgrundlagen. Zusätzliche Anforderungen in Ländern, in denen das Produkt in Verkehr gebracht werden soll, müssen zusätzlich betrachtet werden. Die Herstellung des zertifizierten Produktes wird überwacht. This certificate is based on our Testing and Certification Regulation and states the conformity of the product with the standards and testing requirements as indicated above. Any additional requirements in countries where the product is going to be marketed have to be considered additionally. The manufacturing of the certified product is subject to surveillance.</small>					
TÜV Rheinland LGA Products GmbH - Tillystraße 2 - 90431 Nürnberg					
Tel. (+49/221)8 06 - 13 71 e-mail cert-validity@de.tuv.com				Dipl.-Ing. (FH) M. Geiser	
Fax: (+49/221)8 06 - 39 35 http://www.tuv.com/safety					

Refer to section 1.6 (2) for the models shown in "(see Appendix 1.1)".

APPENDIX

App. 7 When turning on or off the input power supply with DC power supply

App. 7.1 Connection example

For the signals or wiring that are not described in this section, refer to section 3.1.

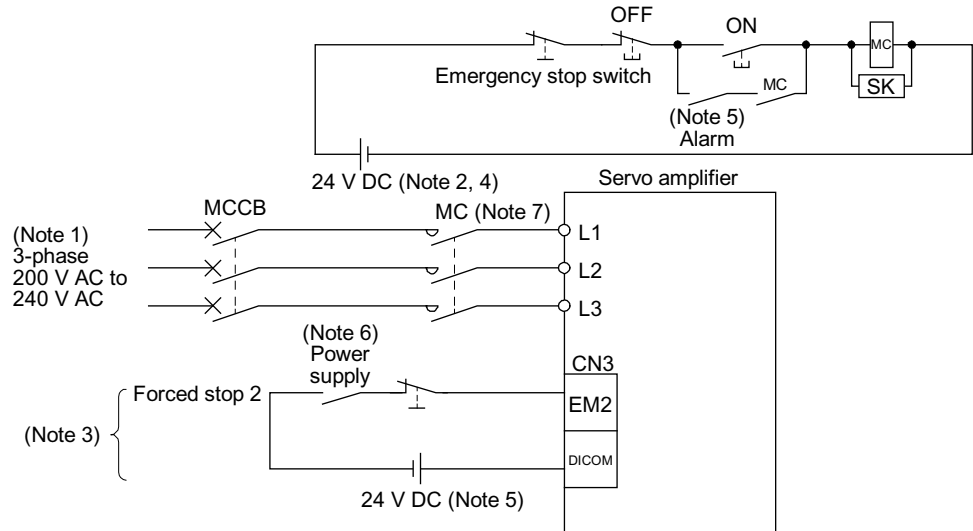

- Note 1. For 1-phase 200 V AC to 240 V AC of MR-JE-10B to MR-JE-100B, connect the power supply to L1 and L3. Leave L2 open. For 1-phase 200 V AC to 240 V AC of MR-JE-200B, connect the power supply to L1 and L2. Leave L3 open. MR-JE-300B is not applicable to 1-phase 200 V AC to 240 V AC power supply.
- Note 2. Do not use the 24 V DC interface power supply for magnetic contactor. Always use the power supply designed exclusively for the magnetic contactor.
- Note 3. This diagram shows sink I/O interface. For source I/O interface, refer to section 3.8.3.
- Note 4. Controlling the on switch or off switch with DC power supply satisfies the requirements of IEC/EN 60204-1.
- Note 5. Configure the power supply circuit that turns off the magnetic contactor after an alarm occurs on the controller side.
- Note 6. Configure a circuit to turn off EM2 when the power is turned off to prevent an unexpected restart of the servo amplifier.
- Note 7. Use a magnetic contactor with an operation delay time (interval since a current is applied to the coil until the contact closes) of 80 ms or shorter. Depending on the power supply voltage and operation pattern, bus voltage can decrease. This can shift the mode to the dynamic brake deceleration during forced stop deceleration. When dynamic brake deceleration is not required, slow the time to turn off the magnetic contactor.

App. 7.2 Magnetic contactor

Use a magnetic contactor with an operation delay time (interval since a current is applied to the coil until the contact closes) of 80 ms or shorter.

Servo amplifier	Magnetic contactor
MR-JE-10B	SD-N11
MR-JE-20B	
MR-JE-40B	
MR-JE-70B	
MR-JE-100B	
MR-JE-200B	SD-N21
MR-JE-300B	

APPENDIX

App. 8 When using the hot line forced stop function in combination with MR-J4-_B servo amplifier and MR-J4W-_B servo amplifier

At factory setting, MR-J4-_B servo amplifiers and MR-J4W-_B servo amplifiers do not decelerate to a stop by the hot line forced stop function if an alarm occurs in an MR-JE-_B servo amplifier.

To decelerate MR-J4-_B servo amplifiers and MR-J4W-_B servo amplifiers to a stop by the hot line forced stop function, enable the deceleration to a stop selection with [Pr. PA27] of the MR-J4-_B servo amplifiers and MR-J4W-_B servo amplifiers.

If an alarm occurs in the MR-J4-_B servo amplifier and MR-J4W-_B servo amplifier, MR-JE-_B, MR-J4-_B, and MR-J4W-_B servo amplifiers do not decelerate to a stop by the hot line forced stop function.

No.	Symbol	Name and function	Initial value [unit]	Setting range														
PA27	*HTL	Hot line forced stop function	<table border="1"> <thead> <tr> <th>Setting digit</th> <th>Explanation</th> <th>Initial value</th> </tr> </thead> <tbody> <tr> <td>___x</td> <td>Deceleration to a stop selection Select enabled/disabled of deceleration to a stop for when a hot line forced stop signal is received. 0: Disabled 2: Enabled This parameter is used by servo amplifier with software version B7 or later.</td> <td>0h</td> </tr> <tr> <td>__x_</td> <td rowspan="3">For manufacturer setting</td> <td>0h</td> </tr> <tr> <td>_x__</td> <td>0h</td> </tr> <tr> <td>x___</td> <td>0h</td> </tr> </tbody> </table>		Setting digit	Explanation	Initial value	___x	Deceleration to a stop selection Select enabled/disabled of deceleration to a stop for when a hot line forced stop signal is received. 0: Disabled 2: Enabled This parameter is used by servo amplifier with software version B7 or later.	0h	__x_	For manufacturer setting	0h	_x__	0h	x___	0h	Refer to the "Name and function" column.
					Setting digit	Explanation	Initial value											
					___x	Deceleration to a stop selection Select enabled/disabled of deceleration to a stop for when a hot line forced stop signal is received. 0: Disabled 2: Enabled This parameter is used by servo amplifier with software version B7 or later.	0h											
					__x_	For manufacturer setting	0h											
					_x__		0h											
x___	0h																	

APPENDIX

App. 9 Optional data monitor function

The optional data monitor function is used to monitor data in the servo amplifier with the servo system controller. With the optional data monitor, the following data types of registered monitor can be set. For details of usage, unit of data type, and others, refer to the manuals for servo system controllers.

Data type	Description
Effective load ratio	The continuous effective load current is displayed. The effective value is displayed considering a rated current as 100%.
Regenerative load ratio	The ratio of regenerative power to permissible regenerative power is displayed in %.
Peak load ratio	The maximum torque generated is displayed. The highest value in the past 15 s is displayed, with the rated torque being 100 %.
Position feedback	Feedback pulses from the servo motor encoder are counted and displayed.
Encoder position within one revolution	The position in servo motor-side 1-revolution is displayed in the encoder pulse unit. When the value exceeds the maximum number of pulses, it resets to 0.
Encoder multiple revolution counter	The rotation amount of the servo motor is displayed. The value is counted up by one per servo motor revolution.
Load inertia moment ratio	The set ratio of the load inertia moment to the servo motor shaft inertia moment is displayed.
Model loop gain	The model loop gain value is displayed.
Main circuit bus voltage	The voltage of main circuit converter is displayed.
Cumulative current value	The cumulative current value of the servo motor is displayed.
Servo motor speed	The servo motor speed is displayed.
Module power consumption	The module power consumption is displayed. The positive value is displayed in power running. The negative value is displayed in regeneration.
Module integral power consumption	The module integral power consumption is displayed.
Instantaneous torque	The instantaneous torque is displayed. The value of torque being occurred is displayed in real time considering a rated torque as 100%.
Servo motor thermistor temperature	The thermistor temperature is displayed for the servo motor with a thermistor. For the servo motor without thermistor, "9999" is displayed. For the servo motor with a thermistor, refer to each servo motor instruction manual.
Disturbance torque	The difference between the torque necessary to drive the servo motor and the actually required torque (Torque current value) is displayed as the disturbance torque.
Overload alarm margin	The margins to the levels which trigger [AL. 50 Overload 1] and [AL. 51 Overload 2] are displayed in percentage.
Error excessive alarm margin	The margin to the level which triggers the error excessive alarm is displayed in units of encoder pulses. The error excessive alarm occurs at 0 pulses.
Settling time	The time (Settling time) after command is completed until INP (In-position) turns on is displayed.
Overshoot amount	The overshoot amount during position control is displayed in units of encoder pulses.
Internal temperature of encoder	The internal temperature of encoder is displayed. When an encoder communication error occurs, the last value will be displayed before the error. This is available with servo amplifiers with software version C4 or later.
Servo command value	The position command from the controller is displayed.
Torque command	The torque command from the controller is displayed.

APPENDIX

App. 10 Using the neutral point of a 3-phase 400 V AC class power supply for inputting a 1-phase 200 V AC class power supply

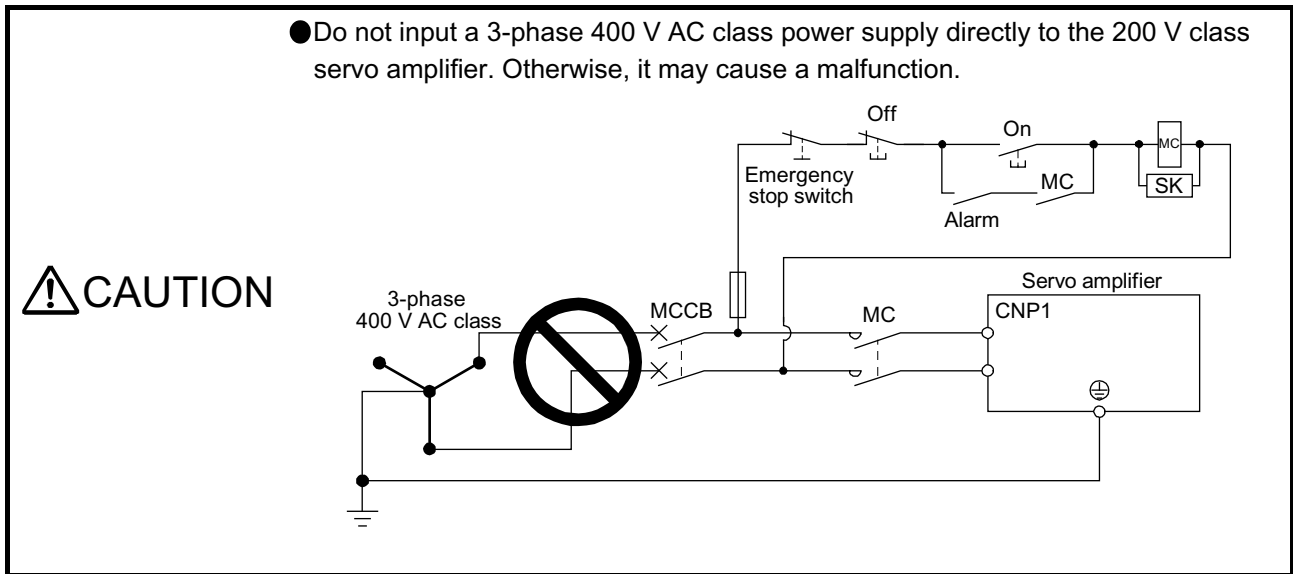

You can use the neutral point of a 3-phase 400 V AC class power supply to input a 1-phase 200 V AC class power supply to the servo amplifier.
If necessary, use a step-down transformer to decrease the power supply voltage to 200 V AC to 240 V AC.

(1) For MR-JE-10B to MR-JE-100B

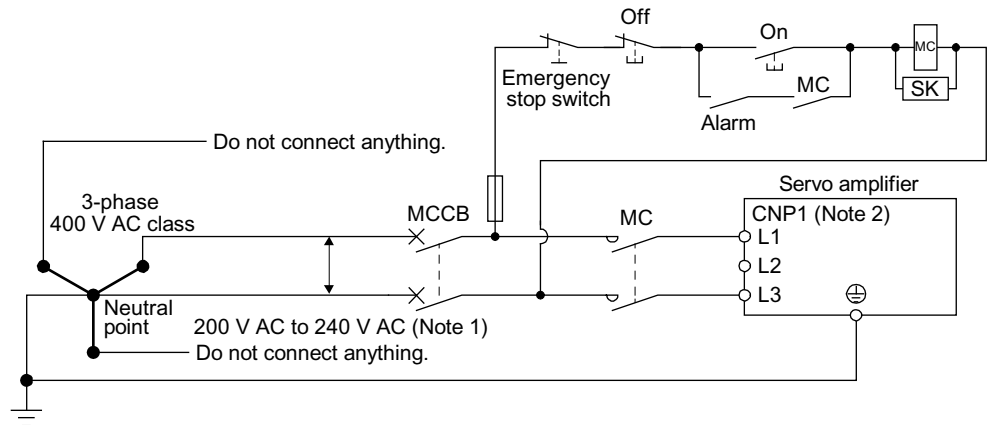

- Note 1. If necessary, use a step-down transformer to decrease the power supply voltage to 200 V AC to 240 V AC.
- Note 2. Connect the 1-phase 200 V AC to 240 V AC power supply to L1 and L3. One of the connecting destinations is different from MR-JE-200B servo amplifier's.

APPENDIX

App. 11 Status of general-purpose AC servo products for compliance with the China RoHS directive





(1) Summary

The China RoHS directive: 电子信息产品污染控制管理办法 (Management Methods for Controlling Pollution by Electronic Information Products) came into effect on March 1, 2007. The China RoHS directive was replaced by the following China RoHS directive: 电器电子产品有害物质限制使用管理办法 (Management Methods for the Restriction of the Use of Hazardous Substances in Electrical and Electronic Products). The succeeding China RoHS directive has been in effect since July 1, 2016. The China RoHS directive restricts the use of six hazardous substances (lead, mercury, cadmium, hexavalent chromium, polybrominated biphenyls (PBB), and polybrominated diphenyl ethers (PBDE)) and other hazardous substances specified by the State (currently no applicable substances). The EU RoHS directive (2011/65/EU) also restricts the use of the above six hazardous substances.

(2) Status of our products for compliance with the China RoHS directive

The following tables show the content of six hazardous substances in our products and Environment-Friendly Use Period marks. Table app. 1 is created based on the standard SJ/T11364.

Table app. 1 Names and the content of hazardous substances in the products

Substance name Threshold standard		Hazardous substance (Note 1)						Environment-Friendly Use Period mark (Note 2)	Remark
		Lead (Pb)	Mercury (Hg)	Cadmium (Cd)	Hexavalent chromium (Cr(VI))	PBB	PBDE		
Part name		Threshold of cadmium: 0.01 wt% (100 ppm), Threshold of substances other than cadmium: 0.1 wt% (1000 ppm)							
Servo amplifier	Mounting board	×	○	○	○	○	○		/
	Heat sink	×	○	○	○	○	○		
	Resin cabinet	○	○	○	○	○	○		
	Plate and screw	○	○	○	○	○	○		
Servo motor	Bracket	×	○	○	○	○	○		/
	Mounting board	×	○	○	○	○	○		
	Resin cabinet	○	○	○	○	○	○		
	Core and cable	○	○	○	○	○	○		
Cable product	Cable	○	○	○	○	○	○		Including connector set
	Connector	○	○	○	○	○	○		
Optional unit	Mounting board	×	○	○	○	○	○		/
	Resin cabinet	○	○	○	○	○	○		
	Plate and screw	○	○	○	○	○	○		

Note 1. ○: Indicates that said hazardous substance contained in all of the homogeneous materials for this part is below the limit requirement of GB/T26572.

×: Indicates that said hazardous substance contained in at least one of the homogeneous materials for this part is above the limit requirement of GB/T26572.

2. Indications based on "Marking for the restriction of the use of hazardous substances in electrical and electronic product" [SJ/T11364-2014]



Indicates that a certain hazardous substance is contained in the product manufactured or sold in China. Observe safety and usage precautions for the product, and use it within a limited number of years from the production date. Thereby, any of the hazardous substances in the product does not cause environmental pollution, or seriously affect human health or property.



Indicates that no certain hazardous substance is contained in the product.

APPENDIX

(3) Difference between the China RoHS directive and the EU RoHS directive

The China RoHS directive allows no restriction exemption unlike the EU RoHS directive. Although a product complies with the EU RoHS directive, a hazardous substance in the product may be considered to be above the limit requirement (marked "x") in the China RoHS directive.

The following shows some restriction exemptions and their examples according to the EU RoHS directive.

- Lead as an alloying element in steel for machining purposes and in galvanized steel containing up to 0.35% lead by weight, lead as an alloying element in aluminum containing up to 0.4% lead by weight, and copper alloy containing up to 4% lead by weight, e.g. brass-made insert nuts
- Lead in high melting temperature type solders (i.e. lead-based alloys containing 85% by weight or more lead)
- Electrical and electronic components containing lead in a glass or ceramic other than dielectric ceramic in capacitors, e.g. piezoelectric devices
- Electrical and electronic components containing lead in a glass or ceramic matrix compound, e.g. chip resistors

(4) Status of our products for compliance with the China RoHS directive (Chinese)

The following shows table app. 1 in Chinese according to "Management Methods for the Restriction of the Use of Hazardous Substances in Electrical and Electronic Products".

表附. 2 产品中所含有害物质的名称及含量

部件名称	物质名称 阈值 基准	有害物质 (注1)						环境保护 使用期限标识 (注2)	备注
		铅 (Pb)	汞 (Hg)	镉 (Cd)	六价铬 (Cr(VI))	PBB	PBDE		
		阈值: 镉: 0.01wt%(100ppm)、 镉以外: 0.1wt%(1000ppm)、							
伺服放大器 伺服系统 控制器	电路板组件	×	○	○	○	○	○		/
	散热片	×	○	○	○	○	○		
	树脂壳体	○	○	○	○	○	○		
	金属板、螺丝	○	○	○	○	○	○		
伺服电机	托架	×	○	○	○	○	○		/
	电路板组件	×	○	○	○	○	○		
	树脂壳体	○	○	○	○	○	○		
	铁心、电线	○	○	○	○	○	○		
电缆 加工品	电线	○	○	○	○	○	○		包括连接器组件
	连接器	○	○	○	○	○	○		
选件 模块	电路板组件	×	○	○	○	○	○		/
	树脂壳体	○	○	○	○	○	○		
	金属板、螺丝	○	○	○	○	○	○		

- 注 1. ○: 表示该有害物质在该部件所有均质材料中的含量均在GB/T26572规定的限量要求以下。
 ×: 表示该有害物质在该部件的至少一种均质材料中的含量超出GB/T26572规定的限量要求。
 2. 根据“电子电气产品有害物质限制使用标识要求”、[SJ/T11364-2014]的表示



该标志表示在中国制造/销售的产品中含有特定有害物质。
 只要遵守本产品的安全及使用方面的注意事项，从生产日算起的环保使用期限内不会造成环境污染或对人体、财产产生深刻的影响。



该标志表示制造的产品中不含有特定有害物质。

APPENDIX

App. 12 Error excessive alarm level adjustment method

If necessary, the error excessive alarm level can be adjusted.

(1) Parameter

The error excessive alarm level can be increased with the following parameter.

Parameter	Symbol	Name	Setting range	Unit
PC01	ERZ	Error excessive alarm level	0 to 1000	[rev unit]
PC06 "x ___"	*COP3	Error excessive alarm/error excessive warning level unit selection 0: 1 rev unit 1: 0.1 rev unit 2: 0.01 rev unit 3: 0.001 rev unit	0 to 3	-

(2) Checking the error excessive alarm margin

Monitor the error excessive alarm margin using the graph function of MR Configurator2. The pulse of the error excessive alarm margin is at a maximum when the command position and feedback position match. [AL. 52 Error excessive] occurs when the error excessive alarm margin is 0 pulses. Calculate the differential pulse using the maximum and minimum pulses in "error excessive alarm margin".

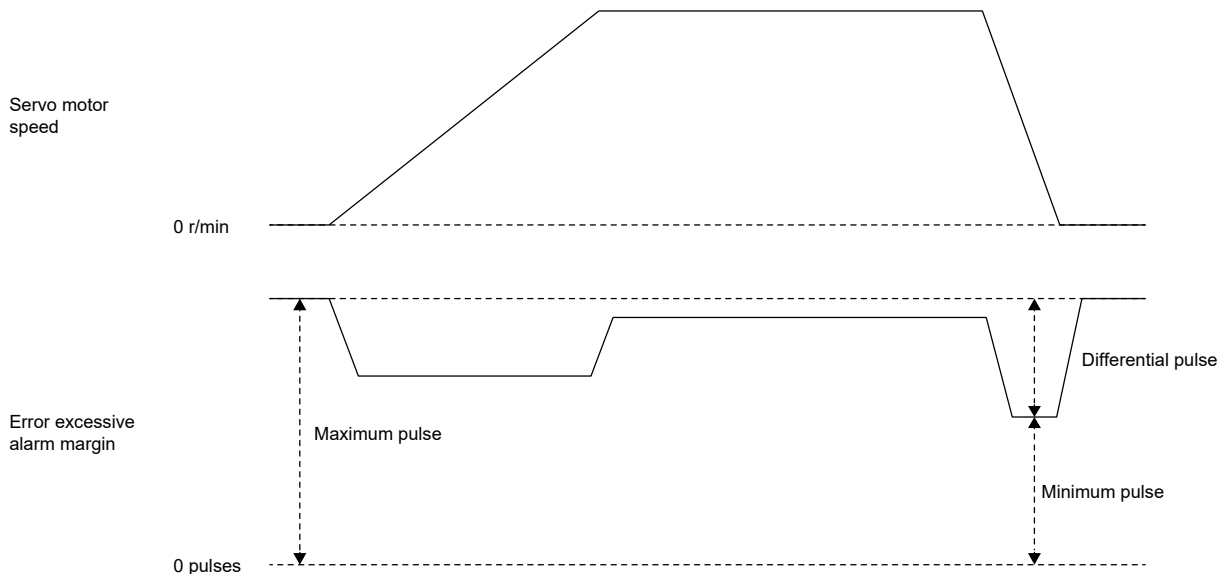

(3) Adjusting the error excessive alarm level

Adjust the error excessive alarm level with "x ___" of [Pr. PC01] and [Pr. PC06] so that the following calculation formula is satisfied.

$$[\text{Pr. PC01}] \times \text{unit set in } [\text{Pr. PC06}] \times \text{"x ___"} > \text{Difference in error excessive alarm margin/resolution per revolution}$$

REVISION

*The manual number is given on the bottom left of the back cover.

Revision Date	*Manual Number	Revision
Nov. 2014	SH(NA)030152ENG-A	First edition
Aug. 2015	SH(NA)030152ENG-B	<p>The content of one-touch tuning is changed.</p> <p>1. To prevent electric shock, note the following. Partially changed.</p> <p>Section 2.6 Partially changed.</p> <p>Section 5.2.2 The content of [Pr. PB06] is added. The content of [Pr. PB56] is added. The content of [Pr. PB57] is added.</p> <p>Section 5.2.3 The content of [Pr. PC24] is added.</p> <p>Section 6.2 The content is changed.</p> <p>Section 7.1.1 Partially changed.</p> <p>Section 8.2 Partially changed.</p> <p>Section 8.3 Partially changed.</p> <p>Section 11.4.2 Partially changed.</p> <p>Section 11.5.2 Partially added.</p> <p>Section 11.12 Partially changed.</p> <p>App. 1 Partially changed.</p> <p>App. 9 Newly added.</p>
May 2016	SH(NA)030152ENG-C	<p>Adaptive filter II is improved.</p> <p>3. To prevent injury, note the following. Partially changed.</p> <p>4. Additional instructions (2), (5), (6) Partially added.</p> <p>Section 1.7.1 Partially changed.</p> <p>Section 2.5 Partially added.</p> <p>Section 3.1 CAUTION is partially changed.</p> <p>Section 3.3.3 Partially added.</p> <p>Chapter 4 CAUTION is partially changed.</p> <p>Section 4.3.3 Partially changed.</p> <p>Section 4.5.2 Partially changed.</p> <p>Section 5.2.2 Partially added to PB01.</p> <p>Section 6.2.3 Partially changed.</p> <p>Section 7.1.2 Partially changed.</p> <p>Section 7.1.4 Partially changed.</p> <p>Section 7.5 Partially changed.</p> <p>Section 8.2 Partially changed.</p> <p>Section 8.3 Partially changed.</p> <p>Section 10.5 POINT is partially changed.</p> <p>Section 11.1.1 Partially added.</p> <p>Section 11.2.2 Partially changed.</p> <p>Section 11.4.2 Partially changed.</p> <p>Section 11.5.4 Partially changed.</p> <p>Section 11.12 Partially changed.</p> <p>App. 1 Partially changed.</p> <p>App. 2 Partially changed.</p> <p>App. 4 Partially changed.</p> <p>App. 8 Partially changed.</p> <p>App. 9 Partially added.</p>
Nov. 2016	SH(NA)030152ENG-D	<p>The HG-KN series servo motors can be operated at a speed of 6000 r/min, and DI/DO are added.</p> <p>4. Additional instructions (1) Transportation and installation The environment is partially changed.</p>

Revision Date	*Manual Number	Revision	
Nov. 2016	SH(NA)030152ENG-D	Section 1.1 Section 1.2 Section 1.3 Section 3.1 Section 3.2 Section 3.3.1 Section 3.3.3 Section 3.4 Section 3.5 Section 3.7.3 Section 3.8.1 Section 3.8.2 Section 3.8.3 Chapter 5 Section 5.1 Section 5.2.1 Section 5.2.4 Section 6.2.3 Section 9.1 Section 10.3.1 Section 11.1.1 Section 11.5.4 App. 4 App. 9 App. 10 App. 11	POINT is added. The diagram is partially changed. Partially changed. CAUTION is partially changed. Note is partially changed. POINT is partially added. The diagrams are partially changed. Partially changed. Partially changed. The diagram is partially changed. Partially changed. The diagrams are partially changed. The diagram is partially changed. Partially changed. Partially changed. The change is made to CAUTION entirely. The parameter is partially added. [Pr. PA28] is added. [Pr. PD02] to [Pr. PD05], [Pr. PD08], and [Pr. PD09] are added. Partially added. Partially changed. The graph is partially changed. Partially changed. Partially changed. Partially changed. Partially changed. Newly added. Newly added.
Aug. 2017	SH(NA)030152ENG-E	A maximum altitude of 2000 m above sea level is supported. 3. To prevent injury, note the following. 4. Additional instructions Section 1.3 Section 1.4 Chapter 2 Section 2.7 Chapter 3 Section 3.3.3 Section 3.5 Section 3.6 Section 3.7 Section 3.10.2 Chapter 4 Section 4.2 Section 5.2.1 Section 5.2.2 Chapter 6 Section 6.2.2 Section 7.1.4 Section 7.1.5 Section 8.2 Section 8.3 Section 10.3 Section 11.1.1	Partially changed. Partially changed. Partially changed. CAUTION is partially changed. Newly added. CAUTION is partially changed. Partially changed. Partially changed. Partially changed. Partially changed. Partially changed. CAUTION is partially changed. Partially changed. Partially changed. Partially changed. CAUTION is partially changed. Partially changed. Partially changed. Partially changed. Partially changed. CAUTION is added. Partially changed.

MELSERVO is a trademark or registered trademark of Mitsubishi Electric Corporation in Japan and/or other countries.
Microsoft, Windows, Internet Explorer, and Windows Vista are registered trademarks or trademarks of Microsoft Corporation in the United States, Japan, and/or other countries.
Intel, Pentium, and Celeron are trademarks of Intel Corporation in the United States and/or other countries.
All other product names and company names are trademarks or registered trademarks of their respective companies.

Warranty

1. Warranty period and coverage

We will repair any failure or defect hereinafter referred to as "failure" in our FA equipment hereinafter referred to as the "Product" arisen during warranty period at no charge due to causes for which we are responsible through the distributor from which you purchased the Product or our service provider. However, we will charge the actual cost of dispatching our engineer for an on-site repair work on request by customer in Japan or overseas countries. We are not responsible for any on-site readjustment and/or trial run that may be required after a defective unit are repaired or replaced.

[Term]

For terms of warranty, please contact your original place of purchase.

[Limitations]

- (1) You are requested to conduct an initial failure diagnosis by yourself, as a general rule.
It can also be carried out by us or our service company upon your request and the actual cost will be charged. However, it will not be charged if we are responsible for the cause of the failure.
- (2) This limited warranty applies only when the condition, method, environment, etc. of use are in compliance with the terms and conditions and instructions that are set forth in the instruction manual and user manual for the Product and the caution label affixed to the Product.
- (3) Even during the term of warranty, the repair cost will be charged on you in the following cases;
 - 1) a failure caused by your improper storing or handling, carelessness or negligence, etc., and a failure caused by your hardware or software problem
 - 2) a failure caused by any alteration, etc. to the Product made on your side without our approval
 - 3) a failure which may be regarded as avoidable, if your equipment in which the Product is incorporated is equipped with a safety device required by applicable laws and has any function or structure considered to be indispensable according to a common sense in the industry
 - 4) a failure which may be regarded as avoidable if consumable parts designated in the instruction manual, etc. are duly maintained and replaced
 - 5) any replacement of consumable parts (battery, fan, smoothing capacitor, etc.)
 - 6) a failure caused by external factors such as inevitable accidents, including without limitation fire and abnormal fluctuation of voltage, and acts of God, including without limitation earthquake, lightning and natural disasters
 - 7) a failure generated by an unforeseeable cause with a scientific technology that was not available at the time of the shipment of the Product from our company
 - 8) any other failures which we are not responsible for or which you acknowledge we are not responsible for

2. Term of warranty after the stop of production

- (1) We may accept the repair at charge for another seven (7) years after the production of the product is discontinued. The announcement of the stop of production for each model can be seen in our Sales and Service, etc.
- (2) Please note that the Product (including its spare parts) cannot be ordered after its stop of production.

3. Service in overseas countries

Our regional FA Center in overseas countries will accept the repair work of the Product. However, the terms and conditions of the repair work may differ depending on each FA Center. Please ask your local FA center for details.

4. Exclusion of loss in opportunity and secondary loss from warranty liability

Regardless of the gratis warranty term, Mitsubishi shall not be liable for compensation to:

- (1) Damages caused by any cause found not to be the responsibility of Mitsubishi.
- (2) Loss in opportunity, lost profits incurred to the user by Failures of Mitsubishi products.
- (3) Special damages and secondary damages whether foreseeable or not, compensation for accidents, and compensation for damages to products other than Mitsubishi products.
- (4) Replacement by the user, maintenance of on-site equipment, start-up test run and other tasks.

5. Change of Product specifications

Specifications listed in our catalogs, manuals or technical documents may be changed without notice.

6. Application and use of the Product

- (1) For the use of our General-Purpose AC Servo, its applications should be those that may not result in a serious damage even if any failure or malfunction occurs in General-Purpose AC Servo, and a backup or fail-safe function should operate on an external system to General-Purpose AC Servo when any failure or malfunction occurs.
- (2) Our General-Purpose AC Servo is designed and manufactured as a general purpose product for use at general industries. Therefore, applications substantially influential on the public interest for such as atomic power plants and other power plants of electric power companies, and also which require a special quality assurance system, including applications for railway companies and government or public offices are not recommended, and we assume no responsibility for any failure caused by these applications when used
In addition, applications which may be substantially influential to human lives or properties for such as airlines, medical treatments, railway service, incineration and fuel systems, man-operated material handling equipment, entertainment machines, safety machines, etc. are not recommended, and we assume no responsibility for any failure caused by these applications when used. We will review the acceptability of the abovementioned applications, if you agree not to require a specific quality for a specific application. Please contact us for consultation.
- (3) Mitsubishi Electric shall have no responsibility or liability for any problems involving programmable controller trouble and system trouble caused by DoS attacks, unauthorized access, computer viruses, and other cyberattacks.

SH(NA)030152ENG-G(2511)MEE

MODEL:

MODEL CODE:

MITSUBISHI ELECTRIC CORPORATION

HEAD OFFICE: TOKYO BLDG., 2-7-3, MARUNOUCHI, CHIYODA-KU, TOKYO 100-8310, JAPAN
NAGOYA WORKS: 1-14, YADA-MINAMI 5-CHOME, HIGASHI-KU, NAGOYA 461-8670, JAPAN

When exported from Japan, this manual does not require application to the
Ministry of Economy, Trade and Industry for service transaction permission.

Specifications subject to change without notice.

Compliance with the indicated global standards and regulations is current as of the release date of this manual.