

General-Purpose AC Servo

MITSUBISHI SERVO AMPLIFIERS & MOTORS
MELSERVO compatible

SERVO MOTOR INSTRUCTION MANUAL

-HG-KN
-HG-SN

● Safety Instructions ●

Please read the instructions carefully before using the equipment.

To use the equipment correctly, do not attempt to install, operate, maintain or inspect the equipment until you have read through this Instruction Manual and appended documents carefully. Do not use the equipment until you have a full knowledge of the equipment, safety information and instructions.

In this Instruction Manual, the safety instruction levels are classified into "WARNING" and "CAUTION".



Indicates that incorrect handling may cause hazardous conditions, resulting in death or severe injury.



Indicates that incorrect handling may cause hazardous conditions, resulting in medium or slight injury to personnel or may cause physical damage.

Note that the  CAUTION level may lead to a serious consequence according to conditions.

Please follow the instructions of both levels because they are important to personnel safety.

What must not be done and what must be done are indicated by the following diagrammatic symbols.



Indicates what must not be done. For example, "No Fire" is indicated by .



Indicates what must be done. For example, grounding is indicated by .

In this Instruction Manual, instructions at a lower level than the above, instructions for other functions, and so on are classified into "POINT".

After reading this Instruction Manual, keep it accessible to the operator.

1. To prevent electric shock, note the following

WARNING

- Before wiring and inspections, turn off the power and wait for 15 minutes or more until the charge lamp turns off. Otherwise, an electric shock may occur. In addition, when confirming whether the charge lamp is off or not, always confirm it from the front of the servo amplifier.
- Ground the servo amplifier and servo motor securely.
- Any person who is involved in wiring and inspection should be fully competent to do the work.
- Do not attempt to wire the servo amplifier and servo motor until they have been installed. Otherwise, it may cause an electric shock.
- The cables should not be damaged, stressed, loaded, or pinched. Otherwise, it may cause an electric shock.
- To avoid an electric shock, insulate the connections of the power supply terminals.

2. To prevent fire, note the following

CAUTION

- Install the servo motor on incombustible material. Installing them directly or close to combustibles will lead to smoke or a fire.
- Provide an adequate protection to prevent screws and other conductive matter, oil and other combustible matter from entering the servo motor.

3. To prevent injury, note the following

CAUTION

- Only the power/signal specified in the Instruction Manual must be supplied/applied to each terminal. Otherwise, an electric shock, fire, injury, etc. may occur.
- Connect cables to the correct terminals. Otherwise, a burst, damage, etc. may occur.
- Ensure that polarity (+/-) is correct. Otherwise, a burst, damage, etc. may occur.
- The servo motor, etc. may be hot while power is on and for some time after power-off. Take safety measures such as providing covers to avoid accidentally touching them by hands and parts such as cables.
- The surface temperature of the servo motor may exceed 100 °C depending on its mounting and operating conditions.
- During operation, never touch the rotor of the servo motor. Otherwise, it may cause injury.

4. Additional instructions

The following instructions should also be fully noted. Incorrect handling may cause a malfunction, injury, electric shock, fire, etc.

(1) Transportation and installation

CAUTION

- Transport the products correctly according to their mass.
- Stacking in excess of the specified number of product packages is not allowed.
- Do not hold the cables, connectors, shaft, or encoder when carrying the servo motor. Otherwise, it may drop.
- Install the servo motor in a load-bearing place in accordance with the Instruction Manual.
- Do not get on or put heavy load on the equipment. Otherwise, it may cause injury.
- The equipment must be installed in the specified direction.
- Do not install or operate the servo motor which have been damaged or have any parts missing.
- Do not drop or strike the servo motor. Otherwise, injury, malfunction, etc. may occur.
- Securely fix the servo motor to the machine. If being attached insecurely, the motor may come off during operation.
- When handling the servo motor, be careful with the sharp edges of the servo motor, shaft keyway, or others.
- Do not strike the connector. Otherwise, a connection failure, malfunction, etc. may occur.
- Be sure to measure the vibration level with the servo motor mounted on the machine when checking the vibration level. A great vibration may cause the early damage of a bearing, encoder, and brake. The great vibration may also cause the poor connector connection or bolt looseness.
- For the gain adjustment at the equipment startup, check the torque waveform and the speed waveform with a measurement device to check that no vibration occurs. If the vibration occurs due to high gain, the vibration may cause the early damage of the servo motor.
- Take safety measures, e.g. provide covers, to prevent accidental access to the rotor of the servo motor during operation.
- Never hit the servo motor or shaft, especially when coupling the servo motor to the machine. Otherwise, the encoder may malfunction.
- Do not subject the servo motor shaft to more than the permissible load. Otherwise, the shaft may break.
- To prevent a fire or injury from occurring in case of an earthquake or other natural disasters, securely install, mount, and wire the servo motor in accordance with the Instruction Manual.
- When you keep or use the equipment, please fulfill the following environment.

Item		Environment
Ambient temperature	Operation	0 °C to 40 °C (non-freezing)
	Storage	-15 °C to 70 °C (non-freezing)
Ambient humidity	Operation	10 %RH to 80 %RH (non-condensing)
	Storage	10 %RH to 90 %RH (non-condensing)
Ambience		Indoors (no direct sunlight), free from corrosive gas, flammable gas, oil mist, dust, and dirt
Altitude		Max. 2000 m above sea level (Note)
Vibration resistance	HG-KN series	X, Y: 49 m/s ²
	HG-SN52/HG-SN102/HG-SN152	X, Y: 24.5 m/s ²
	HG-SN202/HG-SN302	X: 24.5 m/s ² Y: 49 m/s ²

Note. Contact your local sales office for the altitude for options.

(2) Wiring

CAUTION

- Wire the equipment correctly and securely. Otherwise, the servo motor may operate unexpectedly.
- Make sure to connect the cables and connectors by using the fixing screws and the locking mechanism. Otherwise, the cables and connectors may be disconnected during operation.
- Do not install a power capacitor, surge killer, or radio noise filter (optional FR-BIF) on the servo amplifier output side.
- To avoid a malfunction, connect the wires to the correct phase terminals (U/V/W) of the servo amplifier and servo motor.
- Connect the servo amplifier power output (U/V/W) to the servo motor power input (U/V/W) directly. Do not let a magnetic contactor, etc. intervene. Otherwise, it may cause a malfunction.

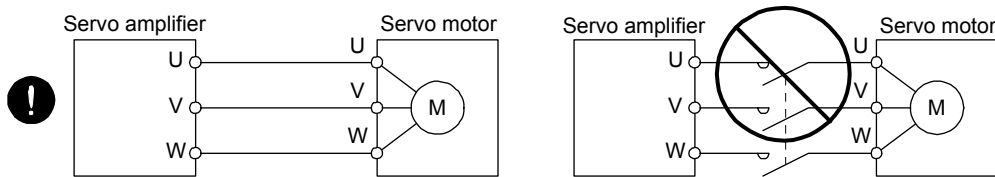

- Do not connect AC power supply directly to the servo motor. Otherwise, it may cause a malfunction.
- When the cable is not tightened enough to the terminal block, the cable or terminal block may generate heat because of the poor contact. Be sure to tighten the cable with specified torque.

(3) Test run and adjustment

CAUTION

- Before operation, check the parameter settings. Improper settings may cause some machines to operate unexpectedly.
- Never make a drastic adjustment or change to the parameter values as doing so will make the operation unstable.

(4) Usage

⚠ CAUTION

- When it is assumed that a hazardous condition may occur due to a power failure or product malfunction, use a servo motor with an external brake to prevent the condition.
- For equipment in which the moving part of the machine may collide against the load side, install a limit switch or stopper to the end of the moving part. The machine may be damaged due to a collision.
- Do not scratch the coated surface with hard objects nor clean the coated surface with an organic solvent. Doing so may scuff the surface.
- Do not disassemble, repair, or modify the product. Otherwise, an electric shock, fire, injury, etc. may occur. Disassembled, repaired, and/or modified products are not covered under warranty.
- Use the servo amplifier with the specified servo motor.
- Correctly wire options and peripheral equipment, etc. in the correct combination. Otherwise, an electric shock, fire, injury, etc. may occur.
- The electromagnetic brake on the servo motor is designed to hold the motor shaft and should not be used for ordinary braking.
- For such reasons as incorrect wiring, service life, and mechanical structure (e.g. where a ball screw and the servo motor are coupled via a timing belt), the electromagnetic brake may not hold the motor shaft. To ensure safety, install a stopper on the machine side.
- If the dynamic brake is activated at power-off, alarm occurrence, etc., do not rotate the servo motor by an external force. Otherwise, it may cause a fire.

(5) Corrective actions

⚠ CAUTION

- Ensure safety by confirming the power off, etc. before performing corrective actions. Otherwise, it may cause an accident.
- When it is assumed that a hazardous condition may occur due to a power failure or product malfunction, use a servo motor with an electromagnetic brake or external brake to prevent the condition.
- Configure an electromagnetic brake circuit which is interlocked with an external emergency stop switch.

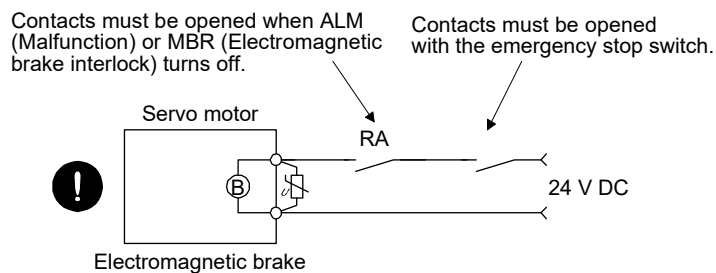

- Failure of MBR (Electromagnetic brake interlock) or ALM (Malfunction) may cause brake malfunction.
- When any alarm has occurred, eliminate its cause, ensure safety, and deactivate the alarm before restarting operation.
- Provide an adequate protection to prevent unexpected restart after an instantaneous power failure.
- To prevent an electric shock, injury, or fire from occurring after an earthquake or other natural disasters, ensure safety by checking conditions, such as the installation, mounting, wiring, and equipment before switching the power on.

(6) Storage

CAUTION

Note the followings when storing the servo motor for an extended period of time (guideline: three or more months).

- Always store the servo motor indoors in a clean and dry place.
- If it is stored in a dusty or damp place, make adequate provision, e.g. cover the whole product.
- If the insulation resistance of the winding decreases, check how to store the equipment.
- Though the motor is rust-proofed before shipment using paint or rust prevention oil, rust may be produced depending on the storage conditions or storage period. If the servo motor is to be stored for longer than six months, apply rust prevention oil again especially to the machined surfaces of the shaft, etc.
- Before using the product after storage for an extended period of time, hand-turn the servo motor output shaft to confirm that nothing is wrong with the servo motor. When the servo motor is equipped with an electromagnetic brake, check it after releasing the electromagnetic brake with the brake power supply.
- When the product has been stored for an extended period of time, contact your local sales office.

(7) General instruction

- To illustrate details, the equipment in the diagrams of this Instruction Manual may have been drawn without covers and safety guards. When the equipment is operated, the covers and safety guards must be installed as specified. Operation must be performed in accordance with this Instruction Manual.

● DISPOSAL OF WASTE ●

Please dispose a servo motor and other options according to your local laws and regulations.

«Cables used for wiring»

Wires mentioned in this Instruction Manual are selected based on the ambient temperature of 40 °C.

«U.S. customary units»

U.S. customary units are not shown in this manual. Convert the values if necessary according to the following table.

Quantity	SI (metric) unit	U.S. customary unit
Mass	1 [kg]	2.2046 [lb]
Length	1 [mm]	0.03937 [inch]
Torque	1 [N·m]	141.6 [oz·inch]
Moment of inertia	1 [(× 10 ⁻⁴ kg·m ²)]	5.4675 [oz·inch ²]
Load (thrust load/axial load)	1 [N]	0.2248 [lbf]
Temperature	N [°C] × 9/5 + 32	N [°F]

CONTENTS

1. INTRODUCTION	1- 1 to 1- 6
1.1 Rating plate.....	1- 1
1.2 Parts identification.....	1- 2
1.3 Electromagnetic brake	1- 3
1.4 Servo motor shaft shapes	1- 5
2. INSTALLATION	2- 1 to 2- 8
2.1 Mounting direction.....	2- 2
2.2 Load mounting/dismounting precautions.....	2- 3
2.3 Permissible load for the shaft	2- 4
2.4 Protection from oil and water	2- 4
2.5 Cable.....	2- 5
2.6 Servo motor with oil seal.....	2- 5
2.7 Inspection items	2- 6
2.8 Parts having service life	2- 6
2.9 Machine accuracies	2- 7
2.10 Mounting servo motors	11- 7
2.11 Restrictions when using the equipment at altitudes exceeding 1000 m and up to 2000 m above sea level.....	11- 7
3. CONNECTORS USED FOR SERVO MOTOR WIRING	3- 1 to 3- 6
3.1 Selection of connectors	3- 1
3.2 Wiring connectors (connector configurations A/B/C).....	3- 2
3.3 Wiring connectors (connector configurations D/E/F/G).....	3- 3
4. CONNECTION OF SERVO AMPLIFIER AND SERVO MOTOR	4- 1 to 4- 8
4.1 Connection instructions	4- 2
4.2 Wiring.....	4- 3
4.2.1 HG-KN series servo motor	4- 3
4.2.2 HG-SN series servo motor	4- 5
4.3 Selection example of wires	4- 7
5. WIRING OPTION	5- 1 to 5-22
5.1 Cable/connector sets	5- 1
5.1.1 Combinations of cable/connector sets	5- 2
5.1.2 Cable and connector list.....	5- 3
5.2 Encoder cable/connector sets	5- 6
5.3 Servo motor power cable.....	5-17
5.4 Electromagnetic brake cable	5-19
5.5 Wires for option cables	5-20
6. HG-KN SERIES	6- 1 to 6-18
6.1 Model designation.....	6- 1
6.2 Combination list of servo motors and servo amplifiers.....	6- 1

6.3	Standard specifications.....	6- 2
6.3.1	Standard specifications list.....	6- 2
6.3.2	Torque characteristics.....	6- 4
6.4	Electromagnetic brake characteristics.....	6- 5
6.5	Servo motors with special shafts.....	6- 6
6.5.1	Key shaft (with 2 round end key).....	6- 6
6.5.2	D cut shaft.....	6- 6
6.6	Servo motor with oil seal.....	6- 7
6.7	Mounting connectors.....	6- 8
6.8	Dimensions.....	6- 9
6.8.1	Standard (without an electromagnetic brake).....	6- 9
6.8.2	With an electromagnetic brake.....	6-13

7. HG-SN SERIES	7- 1 to 7-12
------------------------	---------------------

7.1	Model designation.....	7- 1
7.2	Combination list of servo motors and servo amplifiers.....	7- 1
7.3	Standard specifications.....	7- 2
7.3.1	Standard specifications list.....	7- 2
7.3.2	Torque characteristics.....	7- 4
7.4	Electromagnetic brake characteristics.....	7- 5
7.5	Servo motors with special shafts.....	7- 6
7.6	Servo motor with oil seal.....	7- 6
7.7	Dimensions.....	7- 7
7.7.1	Standard (without an electromagnetic brake).....	7- 7
7.7.2	With an electromagnetic brake.....	7- 9

APPENDIX	App.- 1 to App.-10
-----------------	---------------------------



App. 1	Servo motor ID codes.....	App.- 1
App. 2	Manufacturer list.....	App.- 1
App. 3	Compliance with the CE marking.....	App.- 2
App. 4	Compliance with UL/CSA standard.....	App.- 3
App. 5	Selection example of servo motor power cable.....	App.- 4
App. 6	Connector dimensions.....	App.- 5





1. INTRODUCTION

1. INTRODUCTION

1.1 Rating plate

The following shows an example of rating plate for explanation of each item.

			MITSUBISHI ELECTRIC	AC SERVO MOTOR SERVO MOTEUR AC
	Model	→	HG-KN13J	
	Input power, rated current and rated output	→	3AC 112 V 0.8 A 100W	
	Mass and insulation class	→	0.57 kg Cl.B, A(UL) CONT	
	Rated speed	→	3000 r/min 0-250Hz	
	Induced voltage constant and maximum ambient temperature	→	31 mV/min ⁻¹ 40°C	
	Power factor and IP rating	→	P.F. 98% IP65	
	Serial number (Note 1)	→	SER.M00001234 15X	
	Country of origin and conforming standards	→	MADE IN JAPAN IEC60034-1 FABRIQUE AU JAPON IEC61800-3	
	Manufacturer	→	MITSUBISHI ELECTRIC CORPORATION TOKYO 100-8310 JAPAN	
				

(Note 2)	→	
	→	
	→	
	→	

- Note 1. Production year and month of the servo motor are indicated in a serial number on the rating plate.
 The year and month are indicated by the last two digits of the year and one digit of the month [1 to 9, X (10), Y (11), and Z (12)].
 For January 2012, the Serial No. is like, "SER. _____ 121".
2. Products approved by Certification Bodies are marked. The marks depends on the Certification Bodies.

1. INTRODUCTION

1.2 Parts identification

(1) HG-KN series servo motor

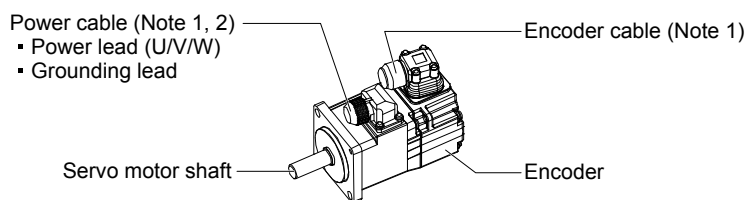

- Note 1. The encoder cable and power supply cable are options.
- Note 2. An electromagnetic brake cable is separately required for the servo motor with an electromagnetic brake.

(2) HG-SN series servo motor

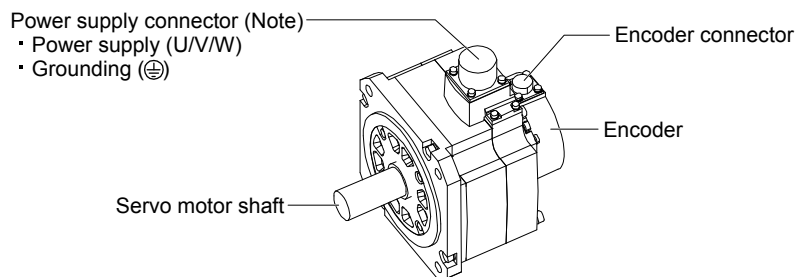

- Note. The servo motor with an electromagnetic brake has the electromagnetic brake connector separately.

1. INTRODUCTION

1.3 Electromagnetic brake

CAUTION

- The electromagnetic brake is provided to prevent a drop at a power failure or alarm occurrence during vertical drive or to hold a shaft at a stop. Do not use it for normal braking (including braking at servo-lock).
- The electromagnetic brake has a time lag. Ensure enough time between releasing the electromagnetic brake and starting the servo motor. Be sure to check the operation delay time with an actual machine.
- Configure an electromagnetic brake circuit so that it is activated also by an external emergency stop switch.
- For details of the circuit configuration and timing chart, refer to each servo amplifier instruction manual.
- While the electromagnetic brake is opened, the motor may be raised to high temperature regardless of driving.
- The life will be shortened under sudden acceleration/deceleration conditions.

The servo motor with an electromagnetic brake can be used to prevent a drop in vertical lift applications or to ensure double safety at an emergency stop, for example. When operating the servo motor, supply power to the electromagnetic brake to release the brake. Switching power off enables the electromagnetic brake.

(1) Electromagnetic brake power supply

Prepare the following power supply for use with the electromagnetic brake only. The electromagnetic brake terminals (B1/B2) have no polarity.

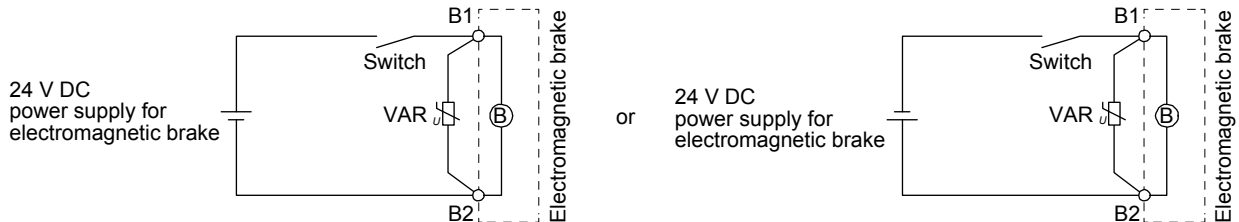

The surge absorber (VAR) must be installed between B1 and B2. For a selection example of the surge absorber, refer to "Electromagnetic brake characteristic" in the chapter of each servo motor series. When you use a diode for a surge absorber, the electromagnetic braking time will be longer.

(2) Sound generation

Though the brake lining may rattle during operation, it poses no functional problem.

If braking sounds, it may be improved by setting the machine resonance suppression filter in the servo amplifier parameters. For details, refer to each servo amplifier instruction manual.

1. INTRODUCTION

(3) Selection of surge absorbers for electromagnetic brake circuit

The following shows an example how to select a varistor with a surge absorber.

(a) Selection conditions

Item	Condition
Electromagnetic brake specification	R [Ω]: Resistance L [H]: Inductance Vb [V]: Power supply voltage
Desired suppression voltage	Vs [V] or less
Durable surge application time	N times

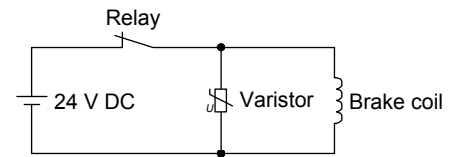

(b) Tentative selection and verification of surge absorber

1) Maximum allowable circuit voltage of varistor

Tentatively select a varistor whose maximum allowable voltage is larger than Vb [V].

2) Brake current (Ib)

$$I_b = \frac{V_b}{R} \text{ [A]}$$

3) Energy (E) generated by brake coil

$$E = \frac{L \times I_b^2}{2} \text{ [J]}$$

4) Varistor limit voltage (Vi)

From the energy (E) generated in the brake coil and the varistor characteristic diagram, calculate the varistor limit voltage (Vi) when the brake current (Ib) flows into the tentatively selected varistor during opening of the circuit.

Vi is favorable when the varistor limit voltage (Vi) [V] is smaller than the desired suppressed voltage (Vs) [V].

If Vi is not smaller than Vs, reselect a varistor or improve the withstand voltage of devices.

5) Surge current width (τ)

Given that the varistor absorbs all energies, the surge current width (τ) will be as follows.

$$\tau = \frac{E}{V_i \times I_b} \text{ [S]}$$

6) Examining surge life of varistor

From the varistor characteristic diagram, find the guaranteed current value (Ip) in which the number of the surge application life is N at the surge current width (τ). Calculate the guaranteed current value (Ip) ratio to brake current (Ib).

If an enough margin is ensured for Ip/Ib, the number of the surge application life N [time] can be considered as favorable.

(4) Others

A leakage magnetic flux will occur at the shaft end of the servo motor equipped with an electromagnetic brake. Note that chips, screws, etc. are attracted.

1. INTRODUCTION

1.4 Servo motor shaft shapes

In addition to the straight shaft, the key shaft and D cut shaft are available.

The key shaft and D cut shaft cannot be used in very frequent start/stop applications.

Since we cannot warrant the servo motor against fracture and similar accidents attributable to a loose key, use a friction coupling, etc. when coupling the shaft with a machine.

The shaft shape of the standard servo motor changes depending on the series and capacity. Refer to the chapter of the servo motor series.

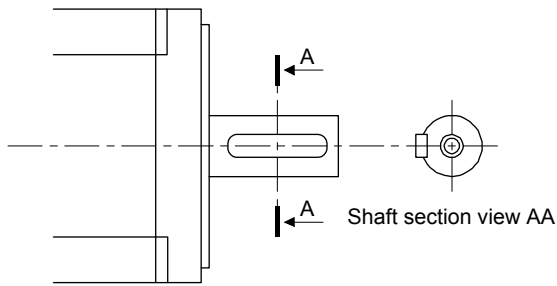

Key shaft (with 2 round end key)

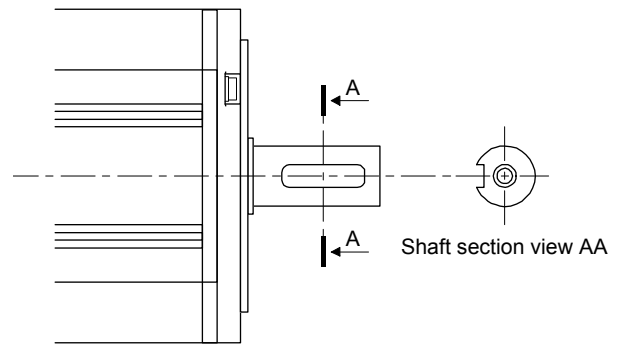

Key shaft (without key)

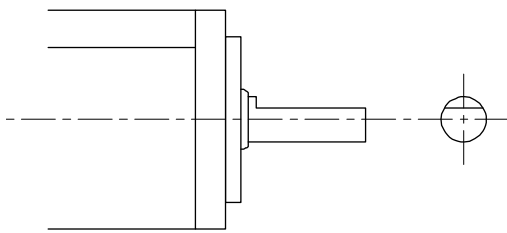

D cut shaft

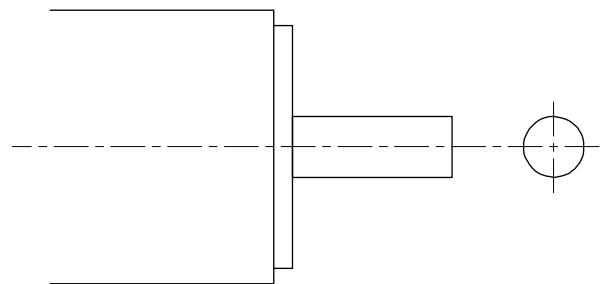

Straight shaft

2. INSTALLATION

2. INSTALLATION

 **WARNING** ● To prevent electric shock, ground each equipment securely.

- Stacking in excess of the specified number of product packages is not allowed.
- Install the equipment on incombustible material. Installing them directly or close to combustibles will lead to smoke or a fire.
- Install the servo motor in a load-bearing place in accordance with the Instruction Manual.
- Do not get on or put heavy load on the equipment. Otherwise, it may cause injury.
- Use the equipment within the specified environment. For the environment, refer to the specifications of the servo motor series.
- Do not drop or strike the servo motor. Isolate it from all impact loads.
- Do not install or operate a faulty servo motor.
- Do not carry the servo motor by holding the cables, connectors, shaft, or encoder. Otherwise, it may drop.
- Securely fix the servo motor to the machine. If being attached insecurely, the motor may come off during operation, leading to injury.
- Be sure to measure the vibration level with the servo motor mounted on the machine when checking the vibration level. A great vibration may cause the early damage to a bearing, encoder, and brake. The great vibration may also cause the poor connector connection or bolt looseness.
- For the gain adjustment at the equipment startup, check the torque waveform and the speed waveform with a measurement device to check that no vibration occurs. If the vibration occurs due to high gain, the vibration may cause the early damage to the servo motor.
- Never hit the servo motor or shaft, especially when coupling the servo motor to the machine. Otherwise, the encoder may malfunction.
- When coupling a load to the servo motor, do not use a rigid coupling. Doing so can cause the shaft to break and the bearing to wear out.
- Balance the load to the extent possible. Not doing so can cause vibration during servo motor operation or damage the bearings and encoder.
- Take safety measures, e.g. provide covers, to prevent accidental access to the rotor of the servo motor during operation.
- Do not subject the servo motor shaft to more than the permissible load. Otherwise, the shaft may break, leading to injury.
- When the product has been stored for an extended period of time, contact your local sales office.
- When handling the servo motor, be careful with the sharp edges of the servo motor, shaft keyway, or others.
- Do not use the servo motor where the shaft-through portion may be subject to pressure (e.g. compressed air). Applying air pressure to the inside of the servo motor may cause a malfunction.

 **CAUTION**

2. INSTALLATION

2.1 Mounting direction

(1) Standard servo motor

The following table indicates the mounting direction of the standard servo motor.

Servo motor series	Mounting direction
HG-KN HG-SN	All direction

For mounting in the horizontal direction, it is recommended to set the connector section downward. When mounting the motor vertically or obliquely, give a little slack for the connection cable.

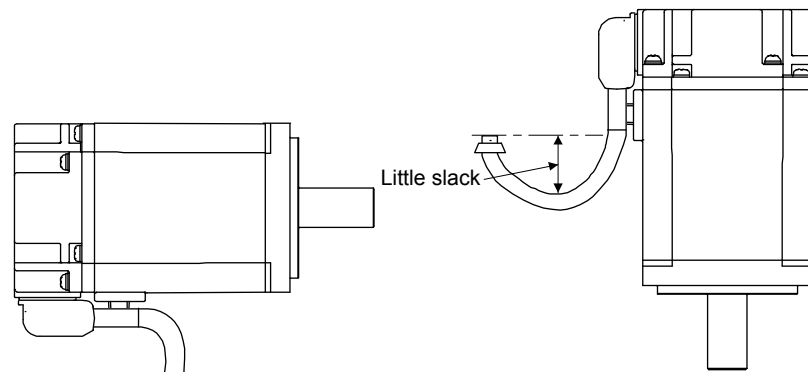

(2) Servo motor with an electromagnetic brake

The servo motor with an electromagnetic brake can also be installed in the same orientation as the standard servo motor. When the servo motor with an electromagnetic brake is installed with the shaft end at top, the brake plate may generate sliding sound but it is not a fault.

2. INSTALLATION

2.2 Load mounting/dismounting precautions

● During assembling, the shaft end must not be hammered. Otherwise, the encoder may malfunction.

CAUTION

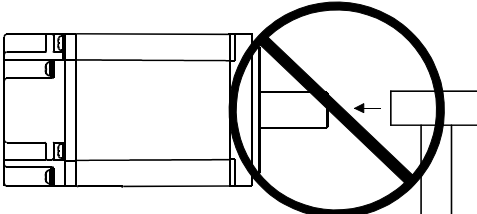

● Do not process the shaft to avoid damage to the encoder and bearing.

- (1) When mounting a pulley to the servo motor with a key shaft, use the screw hole in the shaft end. To fit the pulley, first insert a double-end stud into the screw hole of the shaft, put a washer against the end face of the coupling, and insert and tighten a nut to force the pulley in.

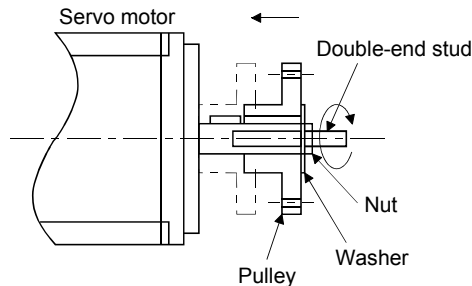

- (2) For the shaft without a key, use a friction coupling or the like.
- (3) When removing the pulley, use a pulley remover to protect the shaft from hard load and or impact.
- (4) To ensure safety, fit a protective cover or the like on the rotary area, such as the pulley, mounted to the shaft.
- (5) When a threaded shaft end part is needed to mount a pulley on the shaft, please contact your local sales office.
- (6) The direction of the encoder on the servo motor cannot be changed.
- (7) When mounting the servo motor, use spring washers, etc. and fully tighten the bolts so that they do not become loose due to vibration.

2. INSTALLATION

2.3 Permissible load for the shaft

CAUTION ● Do not use a rigid coupling as it may apply excessive bending load to the shaft of the servo motor, leading the shaft to break and the bearing to wear out.

For the permissible shaft load specific to the servo motor, refer to the chapter of the servo motor series.

- (1) Use a flexible coupling and adjust the misalignment of the shaft to less than the permissible radial load.
- (2) When using a pulley, sprocket, or timing belt, keep the radial load within the permissible value.
- (3) Excess of the permissible load can cause the bearing life to reduce and the shaft to break.
- (4) The load indicated in this section is static load in a single direction and does not include eccentric load. Make eccentric load as small as possible. Not doing so can cause the servo motor to be damaged.

2.4 Protection from oil and water

Provide adequate protection to prevent foreign matter, such as oil from entering the servo motor shaft. When installing the servo motor, consider the items in this section.

- (1) Do not use the direct drive motor with its cable soaked in oil or water.

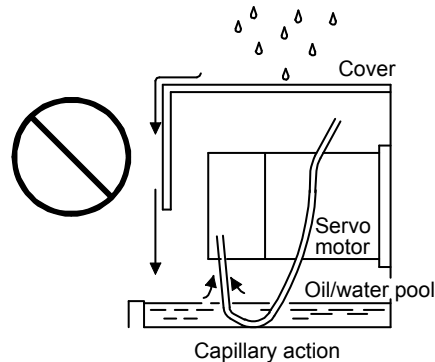

- (2) When the servo motor is to be installed with the shaft end at top, provide measures so that it is not exposed to oil and water entering from the machine side, gear box, etc.

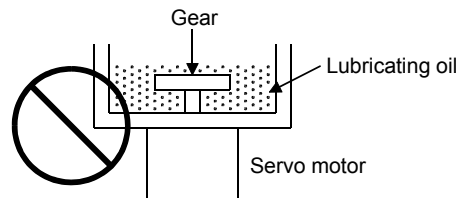

- (3) If oil such as cutting oil drops on the servo motor, the sealant, packing, cable and others may be affected depending on the oil type.
- (4) In the environment where the servo motor is exposed to oil mist, oil, water, grease and/or like, a standard specifications servo motor may not be usable. Please contact your local sales office.

2. INSTALLATION

2.5 Cable

The power supply and encoder cables routed from the servo motor should be fixed to the servo motor to keep them unmovable. Otherwise, the cable may disconnect. In addition, do not modify the connectors, terminals and others at the ends of the cables.

2.6 Servo motor with oil seal

For the servo motor with oil seal, the oil seal prevents the entry of oil into the servo motor. Make sure to install it according in this section.

The functions have no problem even if the servo motor with oil seal may sound during operation.

(1) Pressure and oil level

Install the servo motor horizontally, and set the oil level in the gear box to be lower than the oil seal lip always. If the oil level is higher than the oil seal lip, the oil enter the servo motor and may cause a malfunction. Refer to the chapter of the servo motor series for the height above oil level.

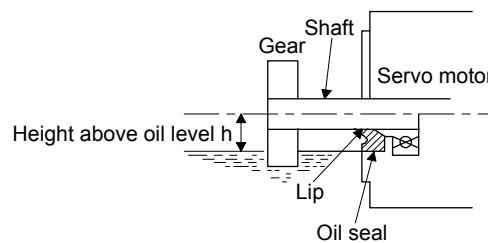

High pressure against the oil seal causes the abrasion and makes the life be short. Keep constant internal pressure by equipping a ventilator to the gear box.

(2) Temperature

High temperature against the oil seal lip makes the life be short. Avoid exposing the oil seal lip to high temperature oil since applicable temperature of the material is up to 100 °C and temperature of the oil seal lip rises within 10 °C to 15 °C at maximum rotation.

2. INSTALLATION

2.7 Inspection items

WARNING

- Before starting maintenance and/or inspection, turn off the power and wait for 15 minutes or more until the charge lamp turns off. Otherwise, an electric shock may occur. In addition, when confirming whether the charge lamp is off or not, always confirm it from the front of the servo amplifier.
- To avoid an electric shock, only qualified personnel should attempt inspections. For repair and parts replacement, contact your local sales office.

CAUTION

- Do not perform insulation resistance test on the servo motor. Otherwise, it may cause a malfunction.
- Do not disassemble and/or repair the equipment on customer side.

It is recommended that the following points periodically be checked.

- (1) Check the bearings, brake section, etc. for unusual noise.
- (2) Check the cables and the like for scratches or cracks. Especially when the cable is movable, perform periodic inspections according to operating conditions.
- (3) Check the servo motor shaft and coupling for misalignment.
- (4) Check the power connector and encoder connector tightening screws for looseness.

2.8 Parts having service life

Service life of the following parts is listed below. However, the service life varies depending on operating methods and environment. If any fault is found in the parts, they must be replaced immediately regardless of their service life. For parts replacement, please contact your local sales office.

Part name	Life guideline
Bearings	20,000 hours to 30,000 hours
Encoder	20,000 hours to 30,000 hours
Oil seal	5000 hours

(1) Bearings

When the motor is run at rated speed under rated load, bearings should be exchanged in 20,000 to 30,000 hours as a guideline. This differs on the operating conditions. The bearings must also be changed if unusual noise or vibration is found during inspection.

(2) Oil seal

Oil seals must be changed in 5,000 hours of operation at rated speed as a guideline. They must also be changed if oil leakage, etc. is found during inspection.

The functions have no problem even if an oil seal may sound during operation.

2. INSTALLATION

2.9 Machine accuracies

The following table indicates the machine accuracies of the servo motor around the output shaft and mounting. (except the optional products)

Accuracy [mm]	Measuring position	Flange size		
		100 × 100 or less	130 × 130	176 × 176
Runout of flange surface to output shaft	a)	0.05	0.06	0.08
Runout of fitting OD of flange surface	b)	0.04	0.04	0.06
Runout of output shaft end	c)	0.02	0.02	0.03

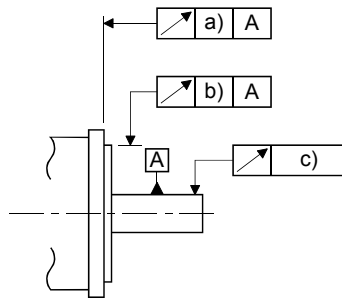

2.10 Mounting servo motors

Be sure to use the servo motor within the specified environment, and mount the servo motor on a machine having the equivalent heat dissipation effect as the following aluminum flange.

The temperature of the servo motor increases differently depending on its mounting environment, operating conditions, etc. Make sure to check the temperature with an actual machine.

Flange size [mm]	Servo motor	
	HG-KN	HG-SN
250 × 250 × 6	13/23	
250 × 250 × 12	43	52/102/152
300 × 300 × 12	73	
300 × 300 × 20		202/302

2.11 Restrictions when using the equipment at altitudes exceeding 1000 m and up to 2000 m above sea level

As heat dissipation effects decrease in proportion to decreasing air density, use the equipment within the effective load ratio and regenerative load ratio shown in the following figure.

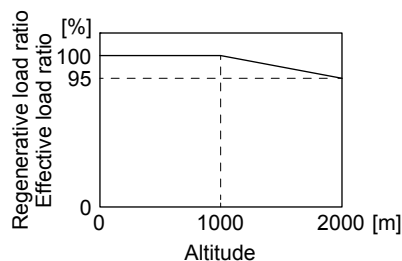

3. CONNECTORS USED FOR SERVO MOTOR WIRING

3. CONNECTORS USED FOR SERVO MOTOR WIRING

POINT
<p>● The IP rating indicated is the connector's protection against ingress of dust and water when the connector is connected to a servo motor. If the IP rating of the connector, and servo motor vary, the overall IP rating depends on the lowest IP rating of all components.</p>

3.1 Selection of connectors

Use the connector configuration products given in the table as the connectors for connection with the servo motor. Refer to section 3.2 and 3.3 for the compatible connector configuration products.

(1) HG-KN series

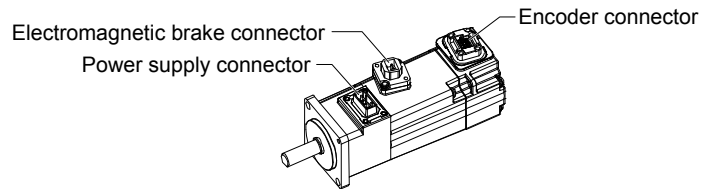

Servo motor	Wiring connector		
	For encoder	For power supply	For electromagnetic brake
HG-KN_	Connector configuration A	Connector configuration B	Connector configuration C

(2) HG-SN series

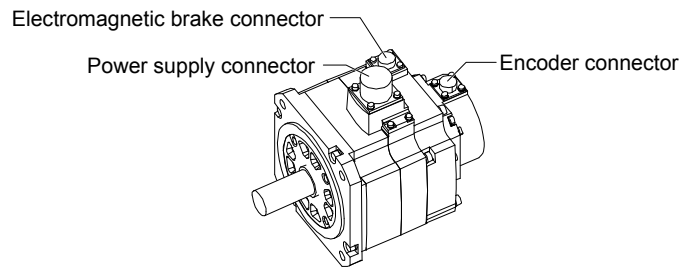

Servo motor	Wiring connector		
	For encoder	For power supply	For electromagnetic brake
HG-SN52 HG-SN102 HG-SN152	Connector configuration D	Connector configuration E	Connector configuration F
HG-SN202 HG-SN302		Connector configuration G	

3. CONNECTORS USED FOR SERVO MOTOR WIRING

3.2 Wiring connectors (connector configurations A/B/C)

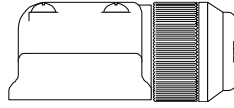

Connector configuration	Feature	Connector	Crimping tool	Servo motor encoder connector (Note)
A (for encoder)	IP65	Connector: 2174053-1 (TE Connectivity)	For ground clip: 1596970-1 For receptacle contact: 1596847-1 (TE Connectivity)	1674339-1 (TE Connectivity)

Note. The connector to be mated.

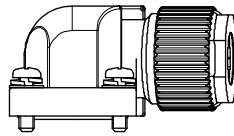

Connector configuration	Feature	Connector	Crimping tool	Servo motor power connector (Note)
B (for power supply)	IP65	Connector: KN4FT04SJ1-R HOOD/SOCKET INSULATOR/BUSHING/GROUND NUT Contact: ST-TMH-S-C1B-100 (A534G) (JAE)	CT170-14-TMH5B (JAE)	JN4AT04NJ1 (JAE)

Note. The connector to be mated.

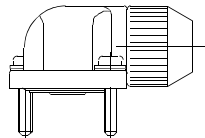

Connector configuration	Feature	Connector	Crimping tool	Servo motor electromagnetic brake connector (Note)
C (for electromagnetic brake)	IP65	Connector: JN4FT02SJ1-R HOOD/SOCKET INSULATOR/BUSHING/GROUND NUT Contact: ST-TMH-S-C1B-100 (A534G) (JAE)	CT170-14-TMH5B (JAE)	JN4AT02PJ1 (JAE)

Note. The connector to be mated.

3. CONNECTORS USED FOR SERVO MOTOR WIRING

3.3 Wiring connectors (connector configurations D/E/F/G)

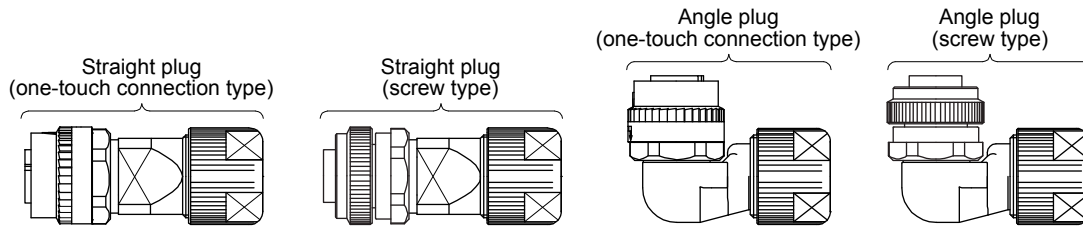

Connector configuration	Feature	Plug (DDK)					Cable OD [mm] (reference)	Servo motor encoder connector (Note)
		Type	Plug	Socket contact	Contact shape			
D (for encoder)	IP67	Straight	CMV1-SP10S-M1 (one-touch connection type) CMV1S-SP10S-M1 (screw type)	CMV1-#22ASC-S1-100	Soldering type Applicable wire size: AWG 20 or less	5.5 to 7.5	CMV1-R10P	
				CMV1-#22ASC-C1-100	Crimping type Applicable wire size: AWG 24 to 20 The crimping tool (357J-53162T) is required.			
				CMV1-#22ASC-C2-100	Crimping type Applicable wire size: AWG 28 to 24 The crimping tool (357J-53163T) is required.			
			CMV1-SP10S-M2 (one-touch connection type) CMV1S-SP10S-M2 (screw type)	CMV1-#22ASC-S1-100	Soldering type Applicable wire size: AWG 20 or less	7.0 to 9.0		
				CMV1-#22ASC-C1-100	Crimping type Applicable wire size: AWG 24 to 20 The crimping tool (357J-53162T) is required.			
				CMV1-#22ASC-C2-100	Crimping type Applicable wire size: AWG 28 to 24 The crimping tool (357J-53163T) is required.			
		Angle	CMV1-AP10S-M1 (one-touch connection type) CMV1S-AP10S-M1 (screw type)	CMV1-#22ASC-S1-100	Soldering type Applicable wire size: AWG 20 or less	5.5 to 7.5		
				CMV1-#22ASC-C1-100	Crimping type Applicable wire size: AWG 24 to 20 The crimping tool (357J-53162T) is required.			
				CMV1-#22ASC-C2-100	Crimping type Applicable wire size: AWG 28 to 24 The crimping tool (357J-53163T) is required.			
			CMV1-AP10S-M2 (one-touch connection type) CMV1S-AP10S-M2 (screw type)	CMV1-#22ASC-S1-100	Soldering type Applicable wire size: AWG 20 or less	7.0 to 9.0		
				CMV1-#22ASC-C1-100	Crimping type Applicable wire size: AWG 24 to 20 The crimping tool (357J-53162T) is required.			
				CMV1-#22ASC-C2-100	Crimping type Applicable wire size: AWG 28 to 24 The crimping tool (357J-53163T) is required.			

Note. The connector to be mated.

3. CONNECTORS USED FOR SERVO MOTOR WIRING

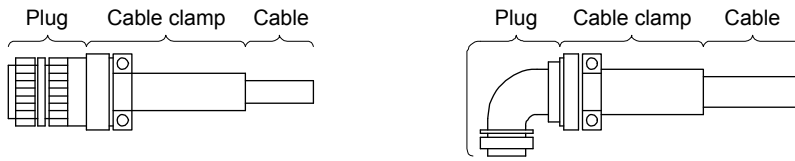

Connector configuration	Feature	Plug (DDK)		Cable clamp (DDK)		Servo motor power connector (Note 2)
		Type	Model	Cable OD [mm] (reference)	Model	
E (for power supply)	IP67 EN compliant	Straight	CE05-6A18-10SD-D-BSS	8.5 to 11	CE3057-10A-2-D	MS3102A18-10P
			Applicable wire size: AWG 14 to 12	10.5 to 14.1	CE3057-10A-1-D	
	Angle	CE05-8A18-10SD-D-BAS	8.5 to 11	CE3057-10A-2-D		
		Applicable wire size: AWG 14 to 12	10.5 to 14.1	CE3057-10A-1-D		
	(Note 1) General environment	Straight	D/MS3106B18-10S	14.3 or less (bushing ID)	D/MS3057-10A	
			Applicable wire size: AWG 14 to 12			
Angle	D/MS3108B18-10S					
	Applicable wire size: AWG 14 to 12					

- Note 1. Not comply with EN.
 2. The connector to be mated.

3. CONNECTORS USED FOR SERVO MOTOR WIRING

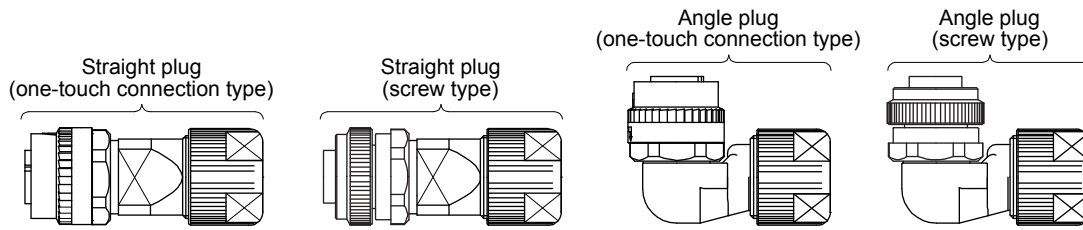

Connector configuration	Feature	Plug (DDK)					Cable OD [mm] (reference)	Servo motor electro-magnetic brake connector (Note)
		Type	Plug	Socket contact	Contact shape			
F (for electro-magnetic brake)	IP67	Straight	CMV1-SP2S-S (one-touch connection type)	CMV1-#22BSC-S2-100	Soldering type Applicable wire size: AWG 16 or less	4.0 to 6.0	CMV1-R2P	
			CMV1S-SP2S-S (screw type)	CMV1-#22BSC-C3-100	Crimping type Applicable wire size: AWG 20 to 16 The crimping tool (357J-53164T) is required.			
			CMV1-SP2S-M1 (one-touch connection type)	CMV1-#22BSC-S2-100	Soldering type Applicable wire size: AWG 16 or less	5.5 to 7.5		
			CMV1S-SP2S-M1 (screw type)	CMV1-#22BSC-C3-100	Crimping type Applicable wire size: AWG 20 to 16 The crimping tool (357J-53164T) is required.			
			CMV1-SP2S-M2 (one-touch connection type)	CMV1-#22BSC-S2-100	Soldering type Applicable wire size: AWG 16 or less	7.0 to 9.0		
			CMV1S-SP2S-M2 (screw type)	CMV1-#22BSC-C3-100	Crimping type Applicable wire size: AWG 20 to 16 The crimping tool (357J-53164T) is required.			
			CMV1-SP2S-L (one-touch connection type)	CMV1-#22BSC-S2-100	Soldering type Applicable wire size: AWG 16 or less	9.0 to 11.6		
			CMV1S-SP2S-L (screw type)	CMV1-#22BSC-C3-100	Crimping type Applicable wire size: AWG 20 to 16 The crimping tool (357J-53164T) is required.			
	IP67	Angle	CMV1-AP2S-S (one-touch connection type)	CMV1-#22BSC-S2-100	Soldering type Applicable wire size: AWG 16 or less	4.0 to 6.0	CMV1-R2P	
			CMV1S-AP2S-S (screw type)	CMV1-#22BSC-C3-100	Crimping type Applicable wire size: AWG 20 to 16 The crimping tool (357J-53164T) is required.			
			CMV1-AP2S-M1 (one-touch connection type)	CMV1-#22BSC-S2-100	Soldering type Applicable wire size: AWG 16 or less	5.5 to 7.5		
			CMV1S-AP2S-M1 (screw type)	CMV1-#22BSC-C3-100	Crimping type Applicable wire size: AWG 20 to 16 The crimping tool (357J-53164T) is required.			
			CMV1-AP2S-M2 (one-touch connection type)	CMV1-#22BSC-S2-100	Soldering type Applicable wire size: AWG 16 or less	7.0 to 9.0		
			CMV1S-AP2S-M2 (screw type)	CMV1-#22BSC-C3-100	Crimping type Applicable wire size: AWG 20 to 16 The crimping tool (357J-53164T) is required.			
			CMV1-AP2S-L (one-touch connection type)	CMV1-#22BSC-S2-100	Soldering type Applicable wire size: AWG 16 or less	9.0 to 11.6		
			CMV1S-AP2S-L (screw type)	CMV1-#22BSC-C3-100	Crimping type Applicable wire size: AWG 20 to 16 The crimping tool (357J-53164T) is required.			

Note. The connector to be mated.

3. CONNECTORS USED FOR SERVO MOTOR WIRING



Connector configuration	Feature	Plug (DDK)		Cable clamp (DDK)		Servo motor power connector (Note 2)
		Type	Model	Cable OD [mm] (reference)	Model	
G (for power supply)	IP67 EN compliant	Straight	CE05-6A22-22SD-D-BSS	9.5 to 13	CE3057-12A-2-D	MS3102A22-22P
			Applicable wire size: AWG 10 to 8	12.5 to 16	CE3057-12A-1-D	
	Angle	CE05-8A22-22SD-D-BAS	9.5 to 13	CE3057-12A-2-D		
		Applicable wire size: AWG 10 to 8	12.5 to 16	CE3057-12A-1-D		
	(Note 1) General environment	Straight	D/MS3106B22-22S	15.9 or less (bushing ID)	D/MS3057-12A	
			Applicable wire size: AWG 10 to 8			
Angle	D/MS3108B22-22S					
	Applicable wire size: AWG 10 to 8					

- Note 1. Not comply with EN.
 2. The connector to be mated.

4. CONNECTION OF SERVO AMPLIFIER AND SERVO MOTOR

4. CONNECTION OF SERVO AMPLIFIER AND SERVO MOTOR

⚠ WARNING

- Any person who is involved in wiring should be fully competent to do the work.
- Ground the servo motor securely.
- Do not attempt to wire the servo motor until it has been mounted. Otherwise, it may cause an electric shock.
- The cables should not be damaged, stressed, loaded, or pinched. Otherwise, it may cause an electric shock.
- To avoid an electric shock, insulate the connections of the power supply terminals.

⚠ CAUTION

- Wire the equipment correctly and securely. Otherwise, the servo motor may operate unexpectedly, resulting in injury.
- Connect cables to the correct terminals. Otherwise, a burst, damage, etc. may occur.
- Ensure that polarity (+/-) is correct. Otherwise, a burst, damage, etc. may occur.
- Do not install a power capacitor, surge killer or radio noise filter (optional FR-BIF) with the power line of the servo motor.
- Do not modify the equipment.
- Connect the servo amplifier power output (U/V/W) to the servo motor power input (U/V/W) directly. Do not let a magnetic contactor, etc. intervene. Otherwise, it may cause a malfunction.

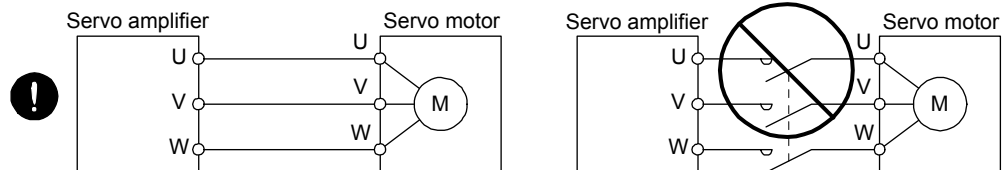

- Before wiring, switch operation, etc., eliminate static electricity. Otherwise, it may cause a malfunction.

4. CONNECTION OF SERVO AMPLIFIER AND SERVO MOTOR

4.1 Connection instructions

CAUTION

- To avoid a malfunction, connect the wires to the correct phase terminals (U/V/W) of the servo amplifier and servo motor.
- Do not connect AC power supply directly to the servo motor. Otherwise, it may cause a malfunction.
- Do not use the 24 V DC interface power supply for the electromagnetic brake. Always use the power supply designed exclusively for the electromagnetic brake. Otherwise, it may cause a malfunction.

POINT

- Refer to chapter 5 for the selection of the encoder cable.
- Refer to the chapter of the servo motor series for the selection of a surge absorber for the electromagnetic brake.

For grounding, connect the grounding lead wire from the servo motor to the protective earth (PE) terminal of the servo amplifier, and then connect the wire from the servo amplifier to the ground via the protective earth of the cabinet. Do not connect the wire directly to the protective earth of the cabinet.

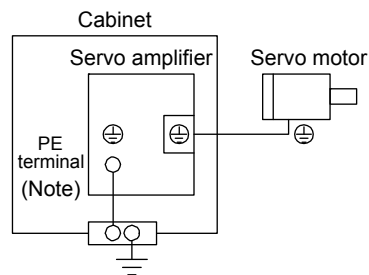

Note. The number of PE terminals of the servo amplifier differs depending on the amplifier types.

4. CONNECTION OF SERVO AMPLIFIER AND SERVO MOTOR

4.2 Wiring

To wire to the servo amplifier, use connectors packed with the amplifier or optional connectors. For servo amplifier terminals, refer to each servo amplifier instruction manual.

4.2.1 HG-KN series servo motor

(1) Servo motor power supply cable wiring diagrams

(a) When cable length is 10 m or less

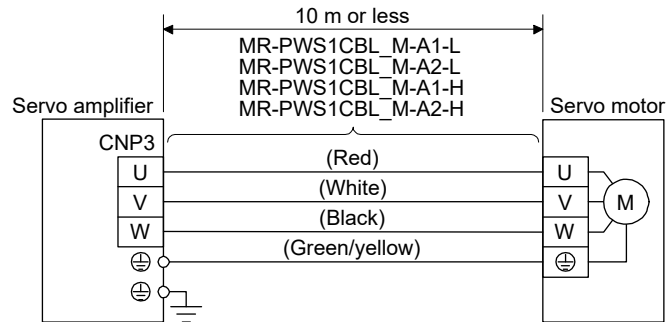

(b) When cable length exceeds 10 m

Fabricate an extension cable as shown below. In addition, the motor power supply cable should be within 2 m.

Refer to section 4.3 for the wire used for the extension cable.

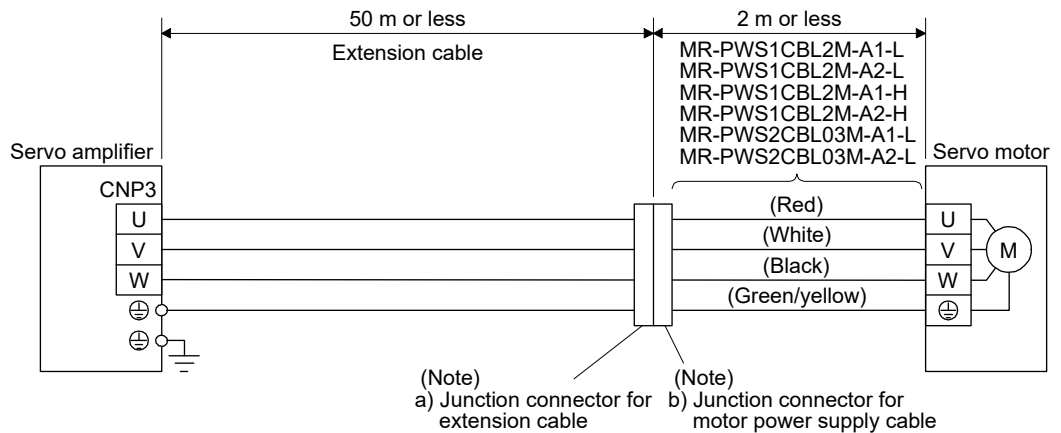

Note. Use of the following connectors is recommended when ingress protection (IP65) is necessary.

Junction connector	Description	IP rating
a) Junction connector for extension cable	Connector: RM15WTPZ-4P(81) Cord clamp: JR13WCC-5(72) (Hirose Electric) — Numeral changes depending on the cable OD.	IP65
b) Junction connector for motor power supply cable	Connector: RM15WTJZ-4S(81) Cord clamp: JR13WCC-8(72) (Hirose Electric) — Numeral changes depending on the cable OD.	IP65

4. CONNECTION OF SERVO AMPLIFIER AND SERVO MOTOR

(2) Electromagnetic brake cable wiring diagrams

(a) When cable length is 10 m or less

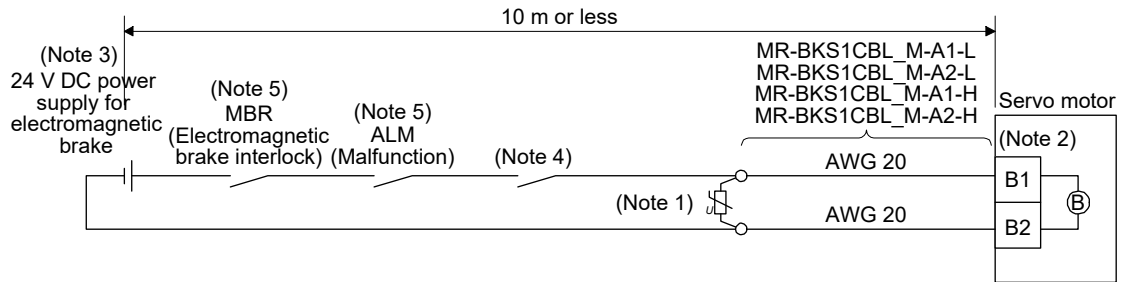

- Note 1. Connect a surge absorber as close to the servo motor as possible.
 Note 2. There is no polarity in electromagnetic brake terminals (B1/B2).
 Note 3. Do not use the 24 V DC interface power supply for the electromagnetic brake.
 Note 4. Create the circuit in order to shut off by interlocking with the emergency stop switch.
 Note 5. Failure of MBR or ALM may cause brake malfunction.

When fabricating the electromagnetic brake cable MR-BKS1CBL-_M_, refer to section 5.4 and section 5.5.

(b) When cable length exceeds 10 m

Fabricate an extension cable as shown below. In addition, the electromagnetic brake cable should be within 2 m.

Refer to section 4.3 for the wire used for the extension cable.

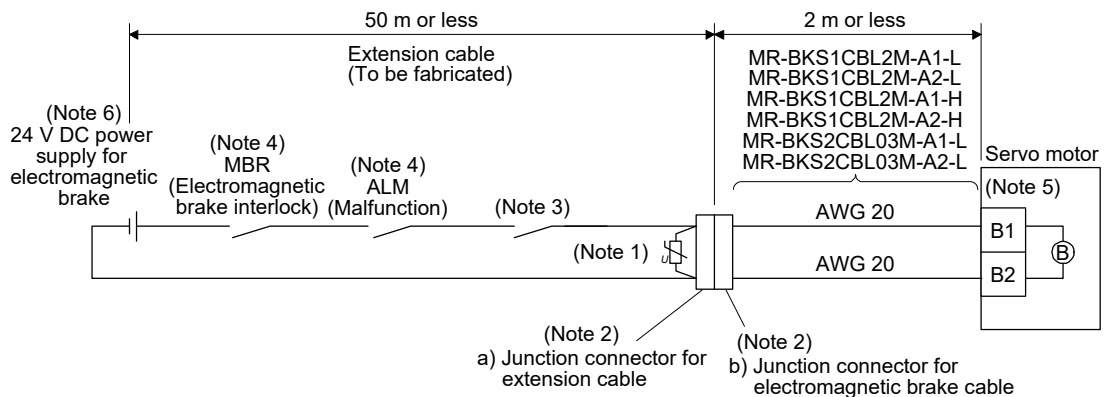

- Note 1. Connect a surge absorber as close to the servo motor as possible.
 Note 2. Use of the following connectors is recommended when ingress protection (IP65) is necessary.

Junction connector	Description	IP rating
a) Junction connector for extension cable	CM10-CR2P-*(DDK) └ Wire size: S, M, L	IP65
b) Junction connector for electromagnetic brake cable	CMV1-SP2S-*(DDK) └ Wire size: S, M1, M2, L	IP65

- Note 3. Create the circuit in order to shut off by interlocking with the emergency stop switch.
 Note 4. Failure of MBR or ALM may cause brake malfunction.
 Note 5. There is no polarity in electromagnetic brake terminals (B1/B2).
 Note 6. Do not use the 24 V DC interface power supply for the electromagnetic brake.

4. CONNECTION OF SERVO AMPLIFIER AND SERVO MOTOR

4.2.2 HG-SN series servo motor

Refer to section 4.3 for the wires used for wiring.

(1) Wiring

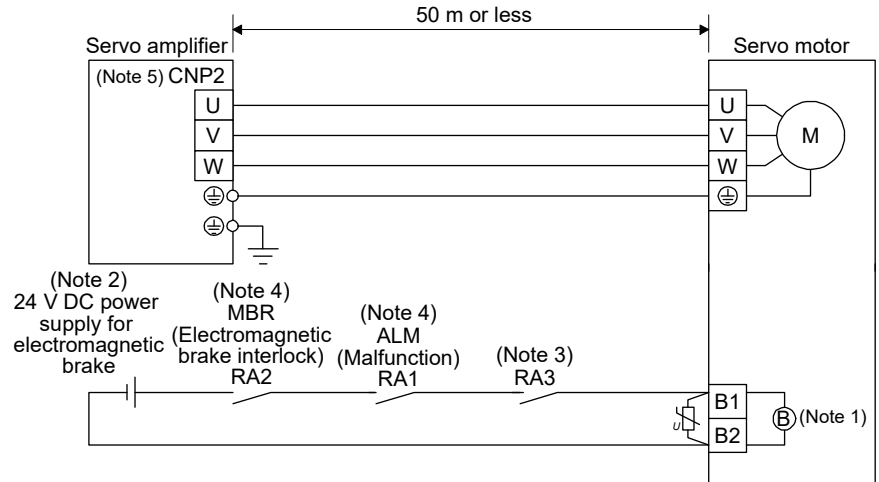

- Note 1. There is no polarity in electromagnetic brake terminals (B1/B2).
- Note 2. Do not use the 24 V DC interface power supply for the electromagnetic brake.
- Note 3. Create the circuit in order to shut off by interlocking with the emergency stop switch.
- Note 4. Failure of MBR or ALM may cause brake malfunction.
- Note 5. The name and shape of connector differ depending on the servo amplifier types.

4. CONNECTION OF SERVO AMPLIFIER AND SERVO MOTOR

(2) Connector

The connector fitting the servo motor is prepared as optional equipment. Refer to chapter 5 for details of the options. For types other than those prepared as optional equipment, refer to chapter 3.

Servo motor	Servo motor-side connectors		
	Encoder	Power supply	Electromagnetic brake
HG-SN52 HG-SN102 HG-SN152	CMV1-R10P (DDK)	MS3102A18-10P	CMV1-R2P (DDK)
HG-SN202 HG-SN302		MS3102A22-22P	

The followings show the encoder connector, power connector, and electromagnetic brake connector viewed from the connection side.

Encoder connector
CMV1-R10P

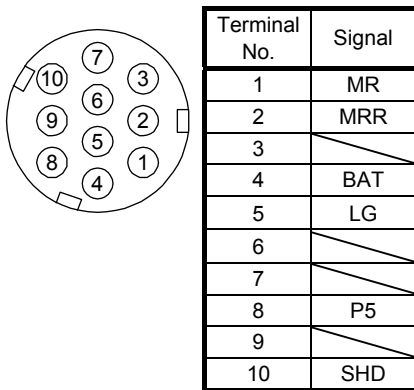

Power connector
MS3102A18-10P
MS3102A22-22P

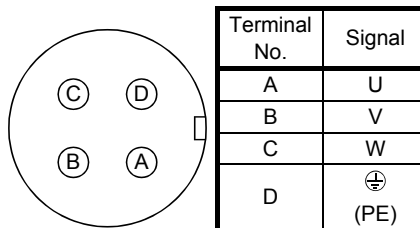

Electromagnetic brake connector
CMV1-R2P

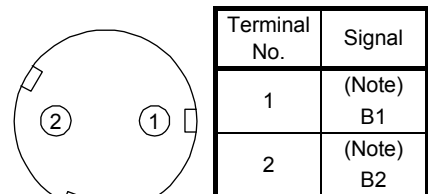

Note. For the motor with an electromagnetic brake, supply electromagnetic brake power (24 V DC). There is no polarity.

4. CONNECTION OF SERVO AMPLIFIER AND SERVO MOTOR

4.3 Selection example of wires

POINT
<ul style="list-style-type: none"> ● Wires indicated in this section are separated wires. When using a cable for power line (U/V/W) between the servo amplifier and servo motor, use a 600 V grade EP rubber insulated chloroprene sheath cab-tire cable (2PNCT). For selection of cables, refer to app. 6. ● To comply with the UL/CSA standard, use the wires shown in app. 4 for wiring. To comply with other standards, use a wire that is complied with each standard. ● Selection conditions of wire size are as follows. Construction condition: Single wire set in midair Wire length: 30 m or less

The following diagram shows the wires used for wiring. Use the wires given in this section or equivalent.

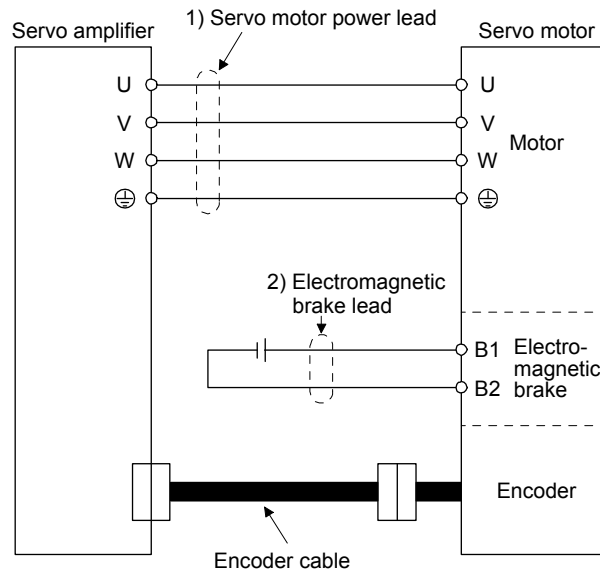

The following shows examples for using the 600 V Grade heat-resistant polyvinyl chloride insulated wire (HIV wire).

Table 4.1 Wire size selection example 2 (HIV wire)

Servo motor	Wire [mm ²]	
	1) U/V/W/⊕	2) B1/B2
HG-KN13	0.75 (AWG 18) (Note)	0.5 (AWG 20) (Note)
HG-KN23		
HG-KN43		
HG-KN73		
HG-SN52	1.25 (AWG 16)	1.25 (AWG 16)
HG-SN102		
HG-SN152	2 (AWG 14)	
HG-SN202		
HG-SN302	3.5 (AWG 12)	

Note. It is for 10 m wire length. When fabricating an extension cable, use 1.25 mm² (AWG 16).

5. WIRING OPTION

5. WIRING OPTION



WARNING

- Before connecting options, turn off the power and wait for 15 minutes or more until the charge lamp turns off. Otherwise, an electric shock may occur. In addition, when confirming whether the charge lamp is off or not, always confirm it from the front of the servo amplifier.



CAUTION

- Use specified options. Otherwise, it may cause a malfunction or fire.

5.1 Cable/connector sets

POINT

- | |
|--------------------------------------------------------------------------------------------------------------------------------------------------------------------------------------------------------------------------------------------------------------------------------------------------------------------------------------------------|
| <ul style="list-style-type: none">● The IP rating indicated for cables and connectors is their protection against ingress of dust and raindrops when they are connected to a servo motor. If the IP rating of the cable, connector, and servo motor vary, the overall IP rating depends on the lowest IP rating of all components. |
|--------------------------------------------------------------------------------------------------------------------------------------------------------------------------------------------------------------------------------------------------------------------------------------------------------------------------------------------------|

Please purchase the cable and connector options indicated in this section for the servo motor.

5. WIRING OPTION

5.1.1 Combinations of cable/connector sets

(1) HG-KN series servo motor

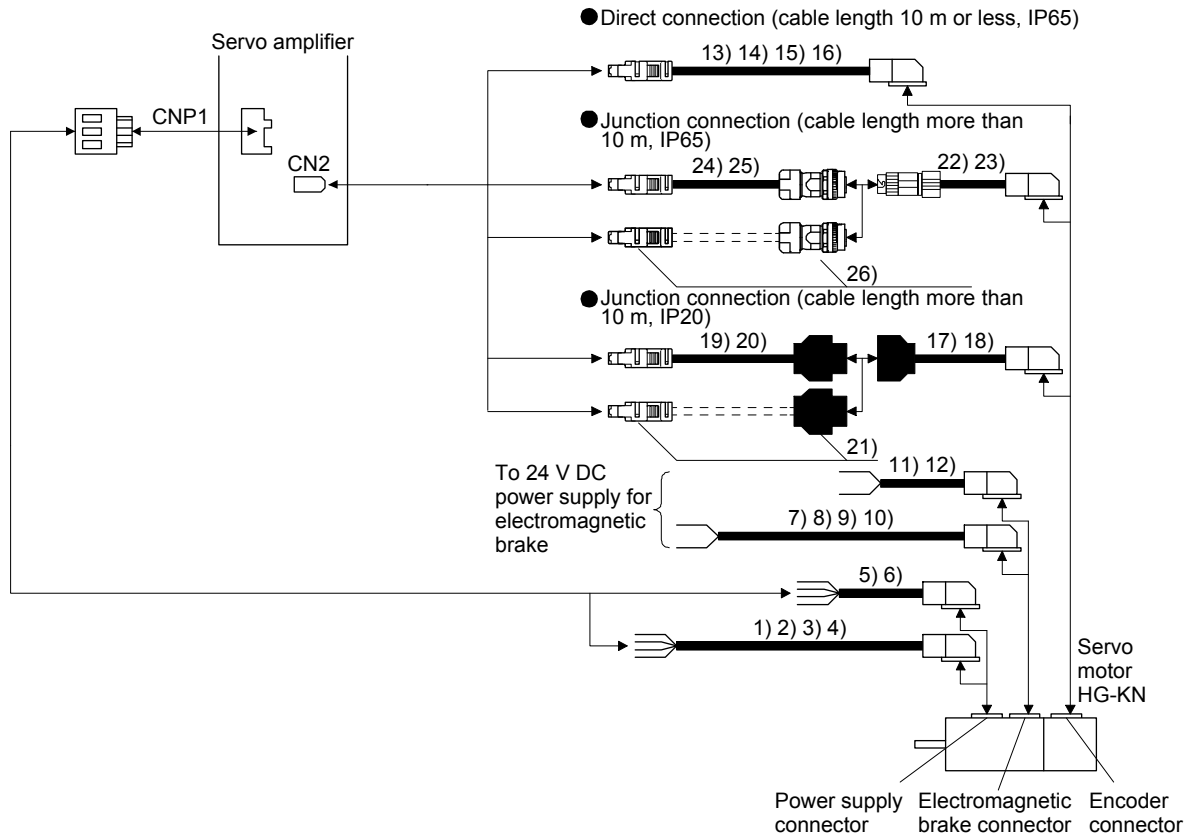

(2) HG-SN series servo motor

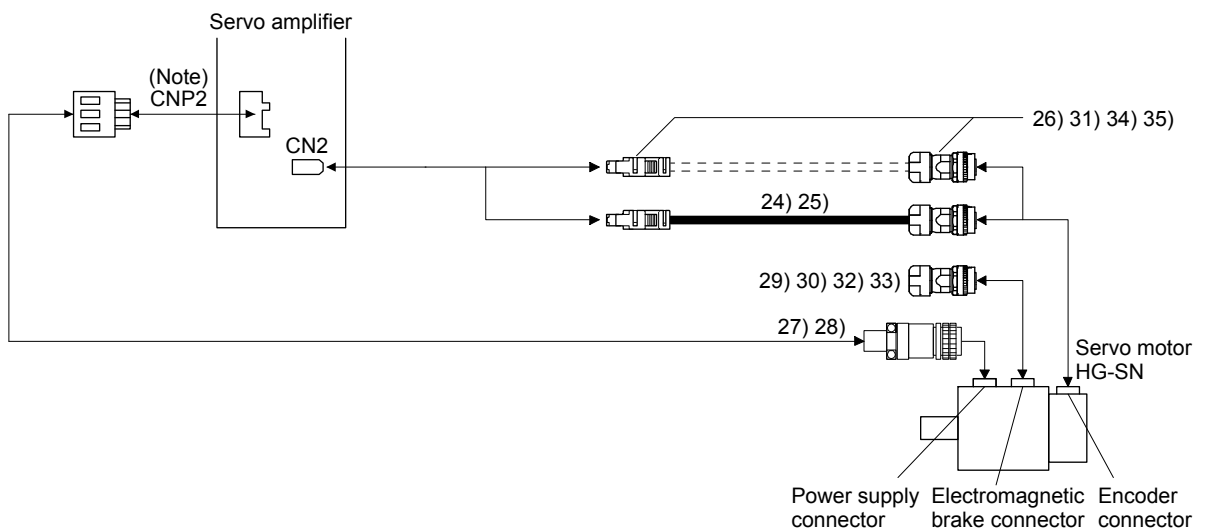



Note. The name and shape of connector differ depending on the servo amplifier types. For connector details, refer to each servo amplifier instruction manual.

5. WIRING OPTION

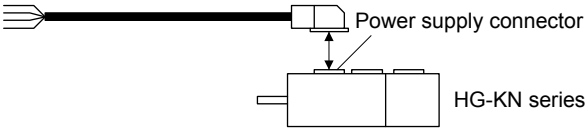
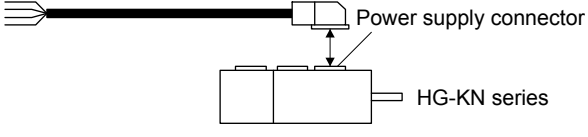
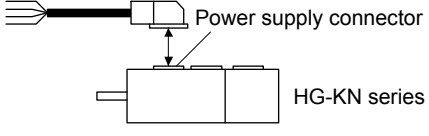
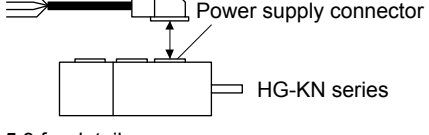
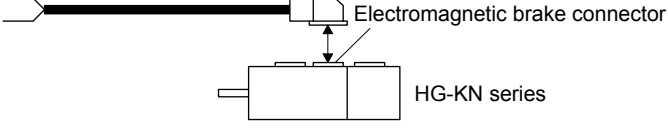
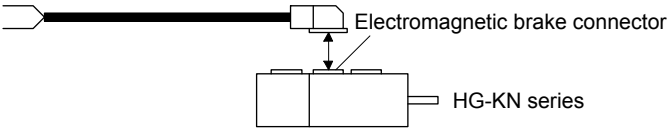



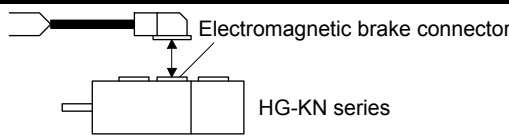
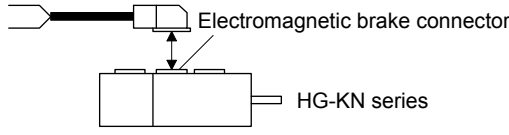
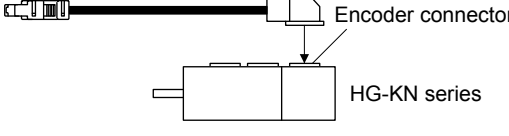
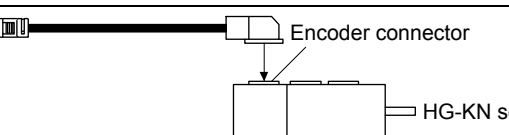
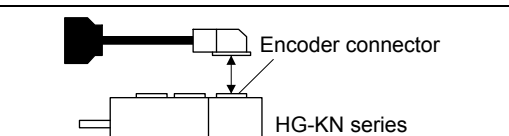
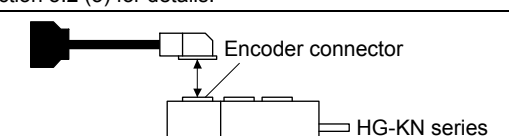
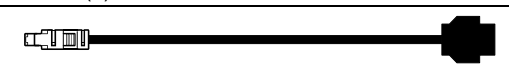

5.1.2 Cable and connector list

No.	Product name	Model	Description	Remark
1)	Servo motor power cable	MR-PWS1CBL_M-A1-L (Note) Cable length: 2/5/10 m	 Power supply connector HG-KN series	IP65 Load-side lead
2)	Servo motor power cable	MR-PWS1CBL_M-A1-H (Note) Cable length: 2/5/10 m	Refer to section 5.3 for details.	IP65 Load-side lead Long bending life
3)	Servo motor power cable	MR-PWS1CBL_M-A2-L (Note) Cable length: 2/5/10 m	 Power supply connector HG-KN series	IP65 Opposite to load-side lead
4)	Servo motor power cable	MR-PWS1CBL_M-A2-H (Note) Cable length: 2/5/10 m	Refer to section 5.3 for details.	IP65 Opposite to load-side lead Long bending life
5)	Servo motor power cable	MR-PWS2CBL03M-A1-L (Note) Cable length: 0.3 m	 Power supply connector HG-KN series	IP55 Load-side lead
6)	Servo motor power cable	MR-PWS2CBL03M-A2-L (Note) Cable length: 0.3 m	 Power supply connector HG-KN series	IP55 Opposite to load-side lead
7)	Electromagnetic brake cable	MR-BKS1CBL_M-A1-L Cable length: 2/5/10 m	 Electromagnetic brake connector HG-KN series	IP65 Load-side lead
8)	Electromagnetic brake cable	MR-BKS1CBL_M-A1-H Cable length: 2/5/10 m	Refer to section 5.4 for details.	IP65 Load-side lead Long bending life
9)	Electromagnetic brake cable	MR-BKS1CBL_M-A2-L Cable length: 2/5/10 m	 Electromagnetic brake connector HG-KN series	IP65 Opposite to load-side lead
10)	Electromagnetic brake cable	MR-BKS1CBL_M-A2-H Cable length: 2/5/10 m	Refer to section 5.4 for details.	IP65 Opposite to load-side lead Long bending life

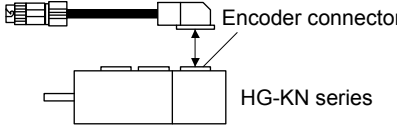
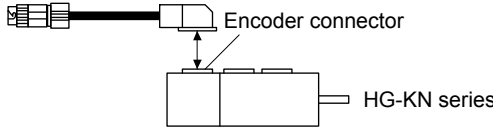

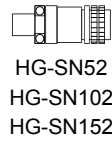

5. WIRING OPTION

No.	Product name	Model	Description	Remark
11)	Electromagnetic brake cable	MR-BKS2CBL03M-A1-L Cable length: 0.3 m	 <p>Electromagnetic brake connector HG-KN series</p> <p>Refer to section 5.4 for details.</p>	IP55 Load-side lead
12)	Electromagnetic brake cable	MR-BKS2CBL03M-A2-L Cable length: 0.3 m	 <p>Electromagnetic brake connector HG-KN series</p> <p>Refer to section 5.4 for details.</p>	IP55 Opposite to load-side lead
13)	Encoder cable	MR-J3ENCBL_M-A1-L (Note) Cable length: 2/5/10 m	 <p>Encoder connector HG-KN series</p> <p>Refer to section 5.2 (1) for details.</p>	IP65 Opposite to load-side lead
14)	Encoder cable	MR-J3ENCBL_M-A1-H (Note) Cable length: 2/5/10 m	Refer to section 5.2 (1) for details.	IP65 Load-side lead Long bending life
15)	Encoder cable	MR-J3ENCBL_M-A2-L (Note) Cable length: 2/5/10 m	 <p>Encoder connector HG-KN series</p> <p>Refer to section 5.2 (1) for details.</p>	IP65 Opposite to load-side lead
16)	Encoder cable	MR-J3ENCBL_M-A2-H (Note) Cable length: 2/5/10 m	Refer to section 5.2 (1) for details.	IP65 Opposite to load-side lead Long bending life
17)	Encoder cable	MR-J3JCBL03M-A1-L (Note) Cable length: 0.3 m	 <p>Encoder connector HG-KN series</p> <p>Refer to section 5.2 (3) for details.</p>	IP20 Load-side lead
18)	Encoder cable	MR-J3JCBL03M-A2-L (Note) Cable length: 0.3 m	 <p>Encoder connector HG-KN series</p> <p>Refer to section 5.2 (3) for details.</p>	IP20 Opposite to load-side lead
19)	Encoder cable	MR-EKCBL_M-L Cable length: 20/30 m	 <p>HG-KN series</p> <p>Refer to section 5.2 (2) for details.</p>	IP20
20)	Encoder cable	MR-EKCBL_M-H Cable length: 20/30/40/50 m		IP20 Long bending life
21)	Encoder connector set	MR-ECNM	 <p>HG-KN series</p> <p>Refer to section 5.2 (2) for details.</p>	IP20

5. WIRING OPTION

No.	Product name	Model	Description	Remark
22)	Encoder cable	MR-J3JSCBL03M-A1-L (Note) Cable length: 0.3 m	 <p>Encoder connector HG-KN series</p> <p>Refer to section 5.2 (4) for details.</p>	IP65 Load-side lead
23)	Encoder cable	MR-J3JSCBL03M-A2-L (Note) Cable length: 0.3 m	 <p>Encoder connector HG-KN series</p> <p>Refer to section 5.2 (4) for details.</p>	IP65 Load-side lead
24)	Encoder cable	MR-J3ENSCBL_M-L (Note) Cable length: 2/5/10/20/30 m	 <p>HG-KN/HG-SN series Refer to section 5.2 (5) for details.</p>	IP67 Standard bending life
25)	Encoder cable	MR-J3ENSCBL_M-H (Note) Cable length: 2/5/10/20/30/40/50 m		IP67 Long bending life
26)	Encoder connector set	MR-J3SCNS (Note)	 <p>HG-KN/HG-SN series Refer to section 5.2 (5) for details.</p>	IP67
27)	Power connector set	MR-PWCNS4	Plug: CE05-6A18-10SD-D-BSS Cable clamp: CE3057-10A-1-D (DDK) Applicable cable Applicable wire size: 2 mm ² to 3.5 mm ² (AWG 14 to 12) Cable outer diameter: 10.5 mm to 14.1 mm  <p>HG-SN52 HG-SN102 HG-SN152</p>	IP67 EN compliant
28)	Power connector set	MR-PWCNS5	Plug: CE05-6A22-22SD-D-BSS Cable clamp: CE3057-12A-1-D (DDK) Applicable cable Applicable wire size: 5.5 mm ² to 8 mm ² (AWG 10 to 8) Cable outer diameter: 12.5 mm to 16 mm  <p>HG-SN202 HG-SN302</p>	IP67 EN compliant
29)	Electromagnetic brake connector set	MR-BKCNS1 (Note)	Straight plug: CMV1-SP2S-L Socket contact: CMV1-#22BSC-S2-100 (DDK)  <p>HG-SN series</p>	IP67
30)	Electromagnetic brake connector set	MR-BKCNS1A (Note)	Angle plug: CMV1-AP2S-L Socket contact: CMV1-#22BSC-S2-100 (DDK)  <p>HG-SN series</p>	IP67
31)	Encoder Connector set	MR-J3SCNSA (Note)	 <p>HG-SN series Refer to section 5.2 (5) for details.</p>	IP67

5. WIRING OPTION

No.	Product name	Model	Description	Remark
32)	Electromagnetic brake connector set	MR-BKCNS2	Straight plug: CMV1S-SP2S-L Socket contact: CMV1-#22BSC-S2-100 (DDK)  HG-SN series	IP67
33)	Electromagnetic brake connector set	MR-BKCNS2A	Angle plug: CMV1S-AP2S-L Socket contact: CMV1-#22BSC-S2-100 (DDK)  HG-SN series	IP67
34)	Encoder connector set	MR-ENCNS2	 HG-SN series Refer to section 5.2 (5) for details.	IP67
35)	Encoder connector set	MR-ENCNS2A	 HG-SN series Refer to section 5.2 (5) for details.	IP67

Note. The cable and the connector set may contain different connectors but still usable.

5.2 Encoder cable/connector sets

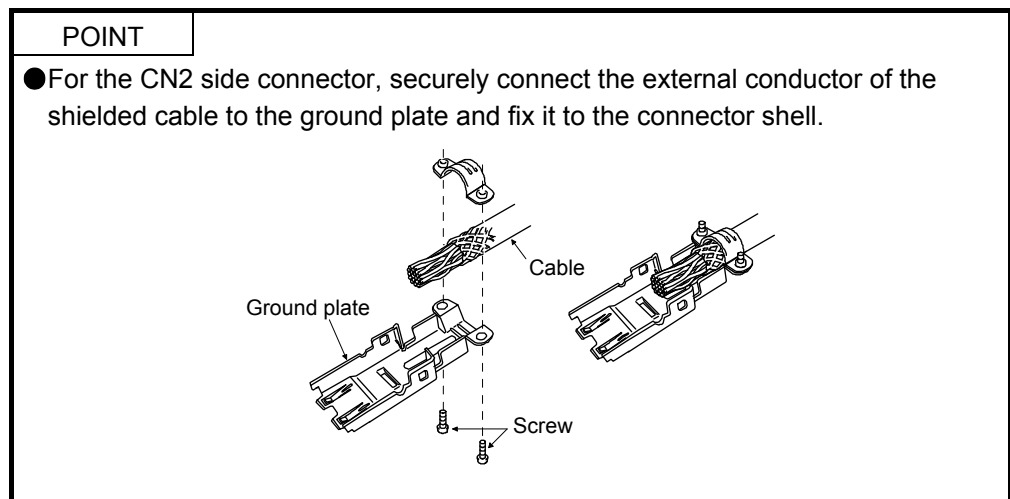

Encoder cables are not subject to European Low Voltage Directive (50 V AC to 1000 V AC and 75 V DC to 1500 V DC).

(1) MR-J3ENCBL_M-_-

These cables are encoder cables for the HG-KN series servo motors. The numbers in the cable length field of the table indicate the symbol filling the underline "_" in the cable model. The cables of the lengths with the numbers are available.

Cable model	Cable length			IP rating	Bending life	Application
	2 m	5 m	10 m			
MR-J3ENCBL_M-A1-L	2	5	10	IP65	Standard	Load-side lead for HG-KN servo motor
MR-J3ENCBL_M-A1-H	2	5	10	IP65	Long bending life	
MR-J3ENCBL_M-A2-L	2	5	10	IP65	Standard	Opposite to load-side lead for HG-KN servo motor
MR-J3ENCBL_M-A2-H	2	5	10	IP65	Long bending life	

5. WIRING OPTION

(a) Connection of servo amplifier and servo motor

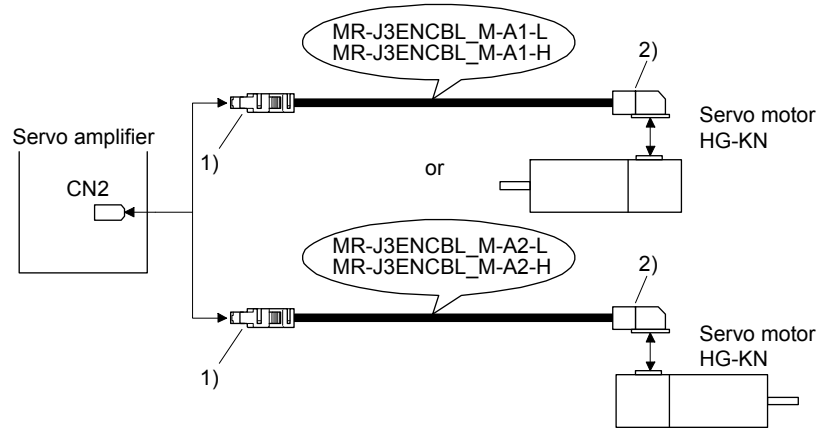

Cable model	1) CN2-side connector		2) Encoder-side connector
MR-J3ENCBL_M-A1-L	Receptacle: 36210-0100PL Shell kit: 36310-3200-008 (3M or equivalent)	Connector set: 54599-1019 (Molex)	Connector: 2174053-1 Crimping tool for ground clip: 1596970-1 Crimping tool for receptacle contact: 1596847-1 (TE Connectivity)
MR-J3ENCBL_M-A1-H		or	
MR-J3ENCBL_M-A2-L		View seen from the wiring side. (Note)	
MR-J3ENCBL_M-A2-H	Note. Do not connect anything to the pins shown as . Especially, pin 10 is provided for manufacturer adjustment. If it is connected with any other pin, the servo amplifier cannot operate normally. Referring to POINT of section 5.2, securely connect the external conductor of the shielded cable to the ground plate and fix it to the connector shell.		View seen from the wiring side. (Note) Note. Do not connect anything to the pins shown as .

(b) Cable internal wiring diagram

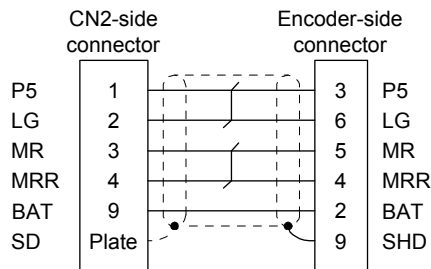

5. WIRING OPTION

(2) MR-EKCBL_M-

POINT
<p>● The following encoder cables are of four-wire type.</p> <p>MR-EKCBL30M-L MR-EKCBL30M-H MR-EKCBL40M-H MR-EKCBL50M-H</p> <p>When using these encoder cables, refer to each servo amplifier instruction manual.</p>

The servo amplifier and the servo motor cannot be connected by these cables alone. The servo motor-side encoder cable (MR-J3JCBL03M- -L) is required.

The numbers in the cable length field of the table indicate the symbol filling the underline " " in the cable model.

Cable model	Cable length				IP rating	Bending life	Application
	20 m	30 m	40 m	50 m			
MR-EKCBL_M-L	20	(Note) 30	△	△	IP20	Standard	For HG-KN servo motor Use in combination with MR-J3JCBL03M- <u> </u> -L.
MR-EKCBL_M-H	20	(Note) 30	(Note) 40	(Note) 50	IP20	Long bending life	

Note. Four-wire type cable

(a) Connection of servo amplifier and servo motor

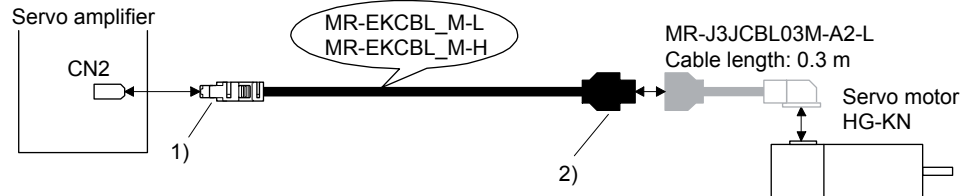

Cable model	1) CN2-side connector		2) Junction connector
MR-EKCBL_M-L	Receptacle: 36210-0100PL Shell kit: 36310-3200-008 (3M)	Connector set: 54599-1019 (Molex)	Housing: 1-172161-9 Connector pin: 170359-1 Crimping tool: 91529-1 (TE Connectivity or equivalent) Cable clamp: MTI-0002 (Toa Electric Industrial)
MR-EKCBL_M-H	<p>View seen from the wiring side. (Note)</p>	or	<p>View seen from the wiring side. (Note)</p>
	<p>Note. Do not connect anything to the pins shown as . Especially, pin 10 is provided for manufacturer adjustment. If it is connected with any other pin, the servo amplifier cannot operate normally. Referring to POINT of section 5.2, securely connect the external conductor of the shielded cable to the ground plate and fix it to the connector shell.</p>		<p>View seen from the wiring side.</p>

5. WIRING OPTION

(b) Internal wiring diagram

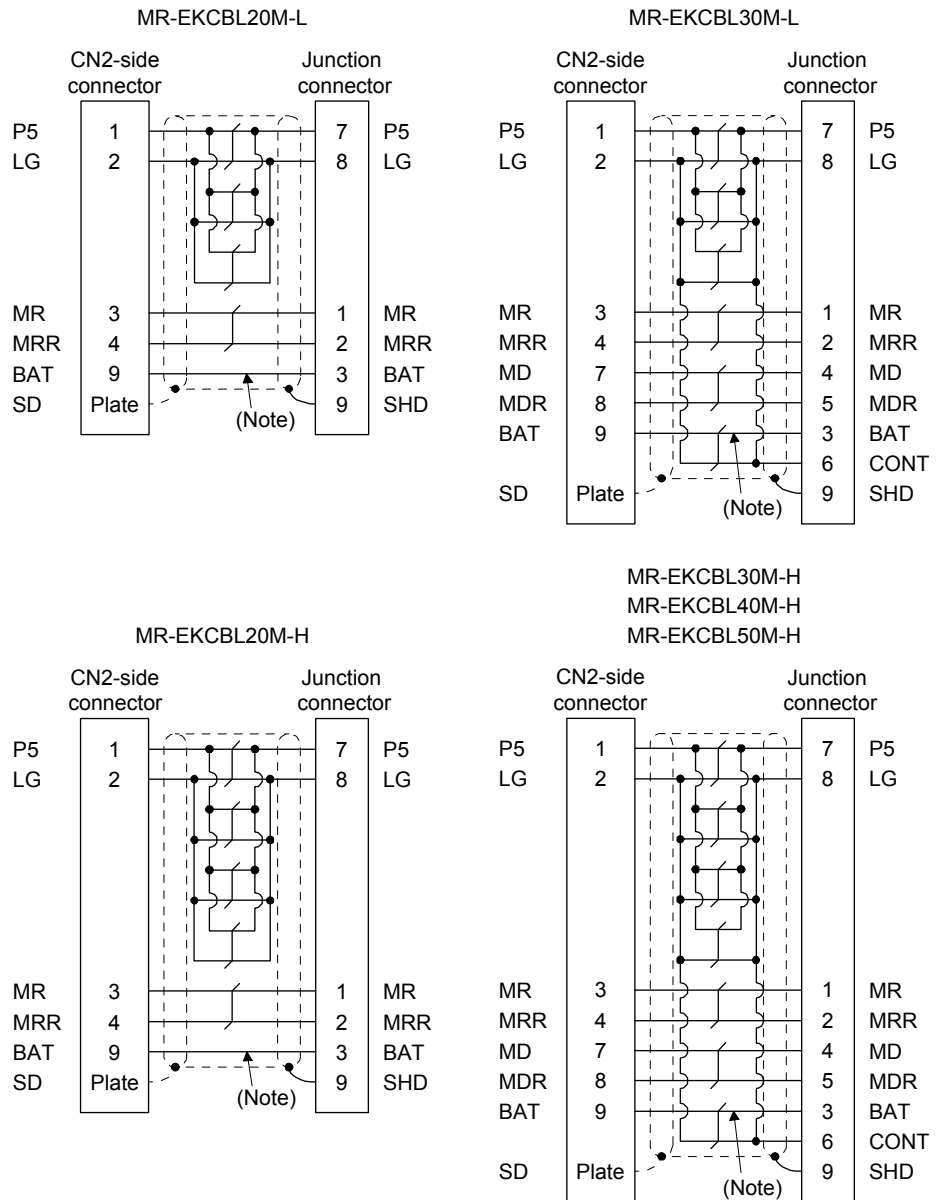

Note. Always make connection for use in an absolute position detection system. Wiring is not necessary for use in an incremental system.

When fabricating the cable, use the wiring diagram corresponding to the length indicated below.



Cable bending life	Applicable wiring diagram	
	Less than 30 m	30 m to 50 m
Standard	MR-EKCBL20M-L	MR-EKCBL30M-L
Long bending life	MR-EKCBL20M-H	MR-EKCBL30M-H MR-EKCBL40M-H MR-EKCBL50M-H

5. WIRING OPTION

(c) When fabricating the encoder cable

Prepare the following parts, and fabricate it according to the wiring diagram in (b) in this section.

Refer to section 5.5 for the specifications of the cable to use.

Parts	Description
Connector set	MR-ECNM
	 
	CN2-side connector Receptacle: 36210-0100PL Shell kit: 36310-3200-008 (3M) or Connector set: 54599-1019 (Molex)
	Encoder-side connector Housing: 1-172161-9 Connector pin: 170359-1 (TE Connectivity or equivalent) Cable clamp: MTI-0002 (Toa Electric Industrial)

(3) MR-J3JCBL03M-_-L

The servo amplifier and the servo motor cannot be connected by these cables alone. The servo motor-side encoder cable (MR-EKCBL_M-_) is required.

Cable model	Cable length	IP rating	Bending life	Application
MR-J3JCBL03M-A1-L	0.3 m	IP20	Standard	Use in combination with load-side lead for HG-KN servo motor MR-EKCBL_M-_.
MR-J3JCBL03M-A2-L				Use in combination with opposite to load-side lead for HG-KN servo motor MR-EKCBL_M-_.

5. WIRING OPTION

(a) Connection of servo amplifier and servo motor

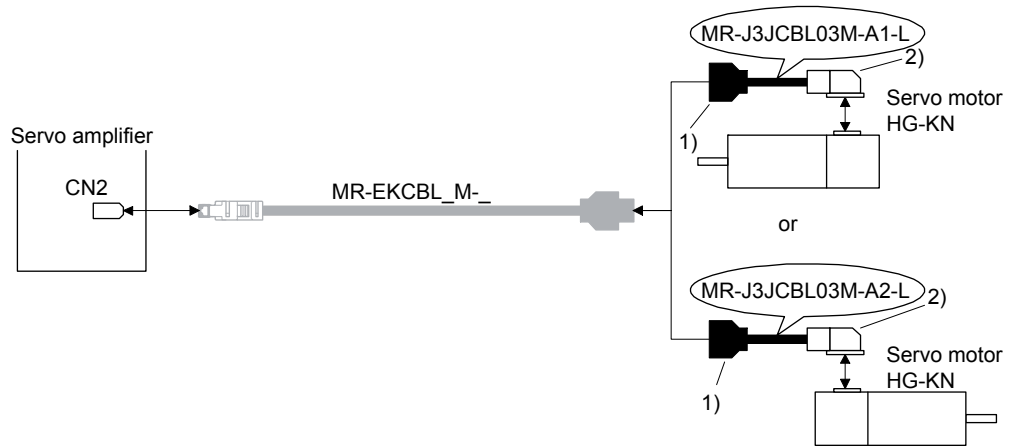

Cable model	1) Junction connector	2) Encoder-side connector
MR-J3JCBL03M-A1-L	Housing: 1-172169-9 Contact: 1473226-1 Cable clamp: 316454-1 Crimping tool: 91529-1 (TE Connectivity)	Connector: 2174053-1 Crimping tool for ground clip: 1596970-1 Crimping tool for receptacle contact: 1596847-1 (TE Connectivity)
MR-J3JCBL03M-A2-L	<p>View seen from the wiring side.</p>	<p>View seen from the wiring side.</p>

(b) Internal wiring diagram

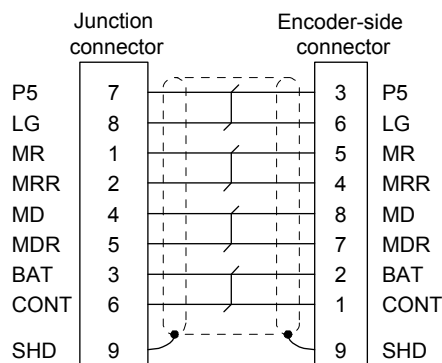

5. WIRING OPTION

(4) MR-J3JSCBL03M-_-L

The servo amplifier and the servo motor cannot be connected by these cables alone. The servo motor-side encoder cable (MR-J3ENSCBL_M-_) is required.

Cable model	Cable length	IP rating	Bending life	Application
MR-J3JSCBL03M-A1-L	0.3 m	IP65	Standard	Use in combination with load-side lead for HG-KN servo motor MR-J3ENSCBL_M-_.
MR-J3JSCBL03M-A2-L				Use in combination with opposite to load-side lead for HG-KN servo motor MR-J3ENSCBL_M-_.

(a) Connection of servo amplifier and servo motor

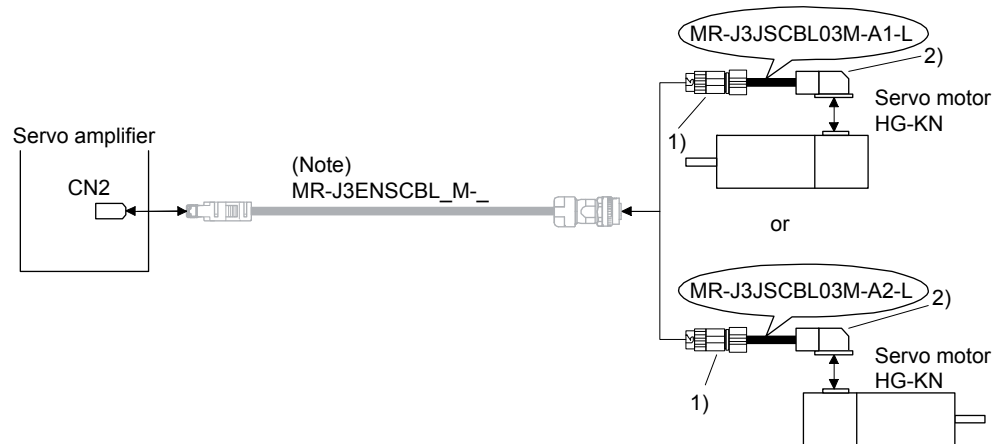

Note. For details of this cable, refer to (5) in this section.

Cable model	1) Junction connector	2) Encoder-side connector
MR-J3JSCBL03M-A1-L	Receptacle: CM10-CR10P-M (DDK) Applicable wire size: AWG 20 or less 	Connector: 2174053-1 Crimping tool for ground clip: 1596970-1 Crimping tool for receptacle contact: 1596847-1 (TE Connectivity)
MR-J3JSCBL03M-A2-L	View seen from the wiring side. (Note) Note. Do not connect anything to the pins shown as .	View seen from the wiring side. (Note) Note. Do not connect anything to the pins shown as .

5. WIRING OPTION

(b) Internal wiring diagram

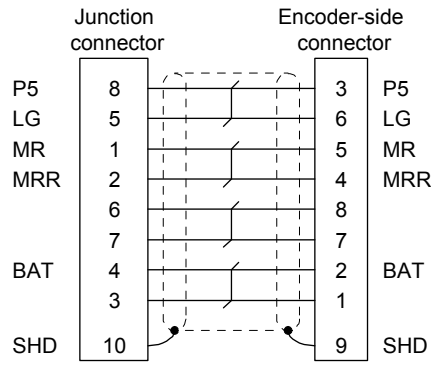

5. WIRING OPTION

(5) MR-J3ENSCBL_M-

These cables are encoder cables for the HG-KN/HG-SN series servo motors. The numbers in the cable length field of the table indicate the symbol filling the underline " " in the cable model.

Cable model	Cable length							IP rating	Bending life	Application
	2 m	5 m	10 m	20 m	30 m	40 m	50 m			
MR-J3ENSCBL_M-L	2	5	10	20	30			IP67	Standard	For HG-KN/HG-SN series servo motor
MR-J3ENSCBL_M-H	2	5	10	20	30	40	50	IP67	Long bending life	

(a) Connection of servo amplifier and servo motor

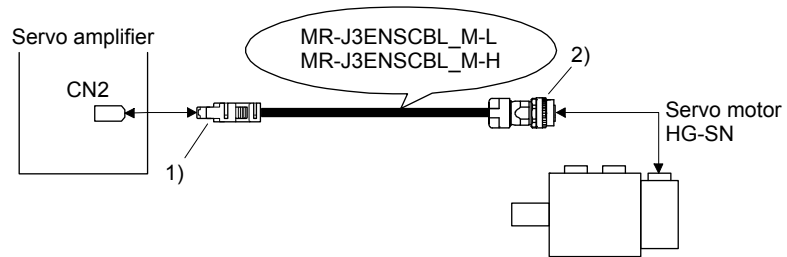

Cable model	1) CN2-side connector	2) Encoder-side connector																		
MR-J3ENSCBL_M-L	<p>Receptacle: 36210-0100PL Shell kit: 36310-3200-008 (3M)</p> <p>View seen from the wiring side. (Note)</p> <p>or</p> <p>Connector set: 54599-1019 (Molex)</p> <p>View seen from the wiring side. (Note)</p> <p>Note. Do not connect anything to the pins shown as . Especially, pin 10 is provided for manufacturer adjustment. If it is connected with any other pin, the servo amplifier cannot operate normally. Referring to POINT of section 5.2, securely connect the external conductor of the shielded cable to the ground plate and fix it to the connector shell.</p>	<table border="1"> <thead> <tr> <th rowspan="2">Cable length</th> <th rowspan="2">Bending life</th> <th colspan="2">Plug (DDK)</th> </tr> <tr> <th>Straight plug</th> <th>Socket contact</th> </tr> </thead> <tbody> <tr> <td rowspan="2">10 m or shorter</td> <td>Long bending life</td> <td rowspan="2">CMV1-SP10S-M1</td> <td>CMV1-#22ASC-C1-100 Applicable wire size: AWG 24 to 20 Crimping tool: 357J-53162T</td> </tr> <tr> <td>Standard</td> <td>CMV1-#22ASC-C2-100 Applicable wire size: AWG 28 to 24 Crimping tool: 357J-53163T</td> </tr> <tr> <td rowspan="2">20 m or more</td> <td>Long bending life</td> <td rowspan="2">CMV1-SP10S-M2</td> <td>CMV1-#22ASC-C2-100 Applicable wire size: AWG 28 to 24 Crimping tool: 357J-53163T</td> </tr> <tr> <td>Standard</td> <td>CMV1-SP10S-M2 Applicable wire size: AWG 28 to 24 Crimping tool: 357J-53163T</td> </tr> </tbody> </table> <p>View seen from the wiring side. (Note)</p> <p>Note. Do not connect anything to the pins shown as .</p>	Cable length	Bending life	Plug (DDK)		Straight plug	Socket contact	10 m or shorter	Long bending life	CMV1-SP10S-M1	CMV1-#22ASC-C1-100 Applicable wire size: AWG 24 to 20 Crimping tool: 357J-53162T	Standard	CMV1-#22ASC-C2-100 Applicable wire size: AWG 28 to 24 Crimping tool: 357J-53163T	20 m or more	Long bending life	CMV1-SP10S-M2	CMV1-#22ASC-C2-100 Applicable wire size: AWG 28 to 24 Crimping tool: 357J-53163T	Standard	CMV1-SP10S-M2 Applicable wire size: AWG 28 to 24 Crimping tool: 357J-53163T
Cable length	Bending life	Plug (DDK)																		
		Straight plug	Socket contact																	
10 m or shorter	Long bending life	CMV1-SP10S-M1	CMV1-#22ASC-C1-100 Applicable wire size: AWG 24 to 20 Crimping tool: 357J-53162T																	
	Standard		CMV1-#22ASC-C2-100 Applicable wire size: AWG 28 to 24 Crimping tool: 357J-53163T																	
20 m or more	Long bending life	CMV1-SP10S-M2	CMV1-#22ASC-C2-100 Applicable wire size: AWG 28 to 24 Crimping tool: 357J-53163T																	
	Standard		CMV1-SP10S-M2 Applicable wire size: AWG 28 to 24 Crimping tool: 357J-53163T																	
MR-J3ENSCBL_M-H	<p>Receptacle: 36210-0100PL Shell kit: 36310-3200-008 (3M)</p> <p>View seen from the wiring side. (Note)</p> <p>Note. Do not connect anything to the pins shown as . Especially, pin 10 is provided for manufacturer adjustment. If it is connected with any other pin, the servo amplifier cannot operate normally. Referring to POINT of section 5.2, securely connect the external conductor of the shielded cable to the ground plate and fix it to the connector shell.</p>	<table border="1"> <thead> <tr> <th rowspan="2">Cable length</th> <th rowspan="2">Bending life</th> <th colspan="2">Plug (DDK)</th> </tr> <tr> <th>Straight plug</th> <th>Socket contact</th> </tr> </thead> <tbody> <tr> <td rowspan="2">10 m or shorter</td> <td>Long bending life</td> <td rowspan="2">CMV1-SP10S-M1</td> <td>CMV1-#22ASC-C1-100 Applicable wire size: AWG 24 to 20 Crimping tool: 357J-53162T</td> </tr> <tr> <td>Standard</td> <td>CMV1-#22ASC-C2-100 Applicable wire size: AWG 28 to 24 Crimping tool: 357J-53163T</td> </tr> <tr> <td rowspan="2">20 m or more</td> <td>Long bending life</td> <td rowspan="2">CMV1-SP10S-M2</td> <td>CMV1-#22ASC-C2-100 Applicable wire size: AWG 28 to 24 Crimping tool: 357J-53163T</td> </tr> <tr> <td>Standard</td> <td>CMV1-SP10S-M2 Applicable wire size: AWG 28 to 24 Crimping tool: 357J-53163T</td> </tr> </tbody> </table> <p>View seen from the wiring side. (Note)</p> <p>Note. Do not connect anything to the pins shown as .</p>	Cable length	Bending life	Plug (DDK)		Straight plug	Socket contact	10 m or shorter	Long bending life	CMV1-SP10S-M1	CMV1-#22ASC-C1-100 Applicable wire size: AWG 24 to 20 Crimping tool: 357J-53162T	Standard	CMV1-#22ASC-C2-100 Applicable wire size: AWG 28 to 24 Crimping tool: 357J-53163T	20 m or more	Long bending life	CMV1-SP10S-M2	CMV1-#22ASC-C2-100 Applicable wire size: AWG 28 to 24 Crimping tool: 357J-53163T	Standard	CMV1-SP10S-M2 Applicable wire size: AWG 28 to 24 Crimping tool: 357J-53163T
Cable length	Bending life	Plug (DDK)																		
		Straight plug	Socket contact																	
10 m or shorter	Long bending life	CMV1-SP10S-M1	CMV1-#22ASC-C1-100 Applicable wire size: AWG 24 to 20 Crimping tool: 357J-53162T																	
	Standard		CMV1-#22ASC-C2-100 Applicable wire size: AWG 28 to 24 Crimping tool: 357J-53163T																	
20 m or more	Long bending life	CMV1-SP10S-M2	CMV1-#22ASC-C2-100 Applicable wire size: AWG 28 to 24 Crimping tool: 357J-53163T																	
	Standard		CMV1-SP10S-M2 Applicable wire size: AWG 28 to 24 Crimping tool: 357J-53163T																	

5. WIRING OPTION

(b) Cable internal wiring diagram

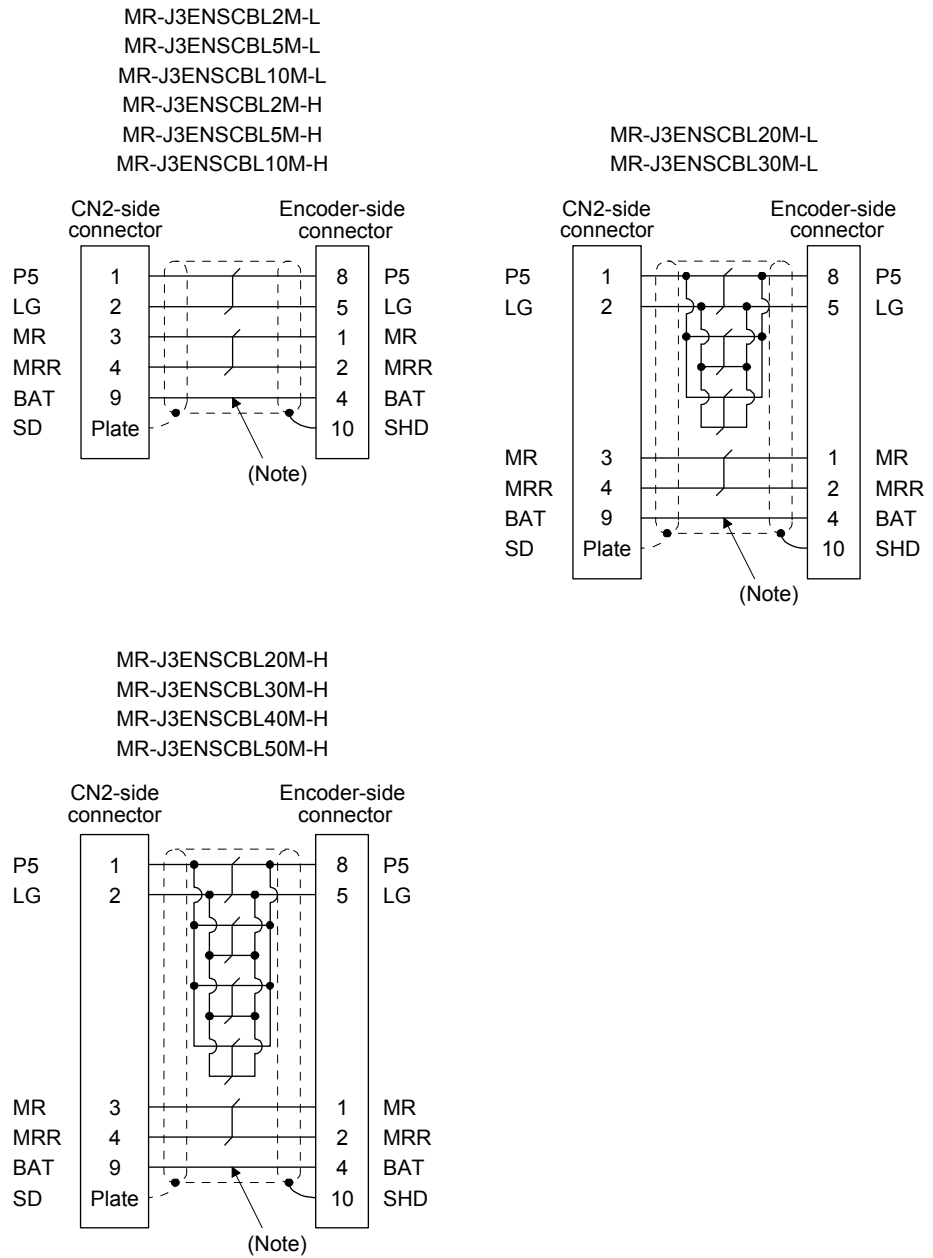





Note. Always make connection for use in an absolute position detection system. Wiring is not necessary for use in an incremental system.

5. WIRING OPTION

(c) When fabricating the encoder cable

Prepare the following parts, and fabricate it according to the wiring diagram in (b) in this section.
Refer to section 5.5 for the specifications of the cable to use.

Parts (Connector set)	Description	
	Servo amplifier-side connector	Encoder-side connector (DDK)
MR-J3SCNS (one-touch connection type) (Note)	 Receptacle: 36210-0100PL Shell kit: 36310-3200-008 (3M)	 Straight plug: CMV1-SP10S-M2 Socket contact: CMV1-#22ASC-S1-100 Applicable wire size: AWG 20 or less
MR-ENCNS2 (screw type) (Note)	or Connector set: 54599-1019 (Molex)	 Straight plug: CMV1S-SP10S-M2 Socket contact: CMV1-#22ASC-S1-100 Applicable wire size: AWG 20 or less
MR-J3SCNSA (one-touch connection type) (Note)		 Angle plug: CMV1-AP10S-M2 Socket contact: CMV1-#22ASC-S1-100 Applicable wire size: AWG 20 or less
MR-ENCNS2A (screw type) (Note)		 Angle plug: CMV1S-AP10S-M2 Socket contact: CMV1-#22ASC-S1-100 Applicable wire size: AWG 20 or less

Note. Cable clamp and bushing for 5.5 mm to 7.5 mm and 7.0 mm to 9.0 mm of cable outer diameter are included.

5. WIRING OPTION

5.3 Servo motor power cable

These cables are servo motor power cables for the HG-KN series servo motors.

The numbers in the cable length field of the table indicate the symbol filling the underline "_" in the cable model.

Refer to section 4.2.1 for wiring.

Cable model	Cable length				IP rating	Bending life	Application
	0.3 m	2 m	5 m	10 m			
MR-PWS1CBL_M-A1-L		2	5	10	IP65	Standard	Load-side lead for HG-KN servo motor
MR-PWS1CBL_M-A2-L		2	5	10	IP65	Standard	Opposite to load-side lead for HG-KN servo motor
MR-PWS1CBL_M-A1-H		2	5	10	IP65	Long bending life	Load-side lead for HG-KN servo motor
MR-PWS1CBL_M-A2-H		2	5	10	IP65	Long bending life	Opposite to load-side lead for HG-KN servo motor
MR-PWS2CBL03M-A1-L	03				IP55	Standard	Load-side lead for HG-KN servo motor
MR-PWS2CBL03M-A2-L	03				IP55	Standard	Opposite to load-side lead for HG-KN servo motor

(1) Connection of servo amplifier and servo motor

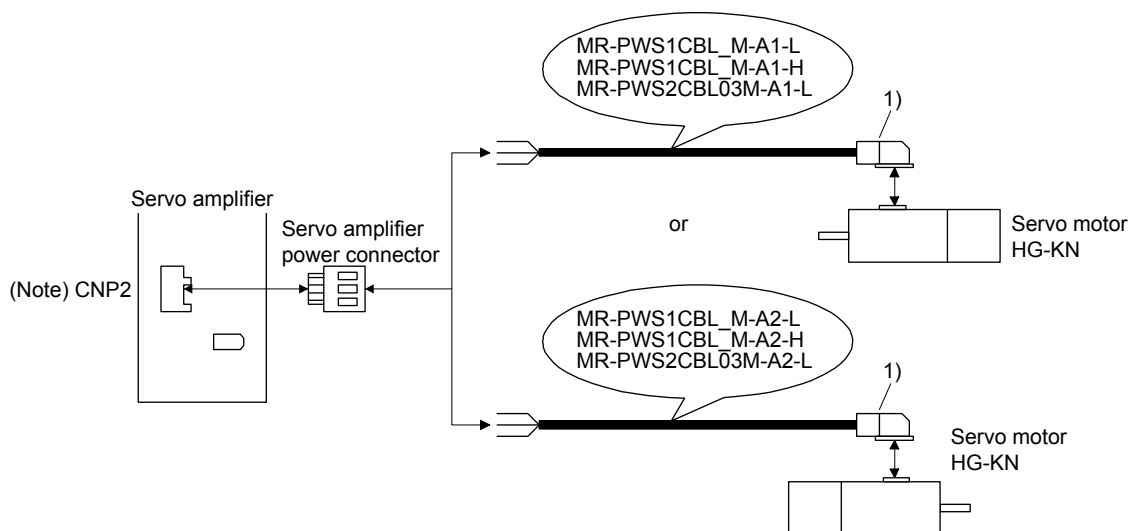

Note. The name and shape of connector differ depending on the servo amplifier types. For connector details, refer to each servo amplifier instruction manual.

Cable model	1) Servo motor power-side connector	
MR-PWS1CBL_M-A1-L	Connector: KN4FT04SJ1-R Hood, socket insulator Bushing, ground nut Contact: ST-TMH-S-C1B-100-(A534G) Crimping tool: CT170-14-TMH5B (JAE)	<p>View seen from the wiring side.</p>
MR-PWS1CBL_M-A2-L		
MR-PWS1CBL_M-A1-H		
MR-PWS1CBL_M-A2-H		
MR-PWS2CBL03M-A1-L	Connector: KN4FT04SJ2-R Hood, socket insulator Bushing, ground nut Contact: ST-TMH-S-C1B-100-(A534G) Crimping tool: CT170-14-TMH5B (JAE)	
MR-PWS2CBL03M-A2-L		

5. WIRING OPTION

(2) Internal wiring diagram

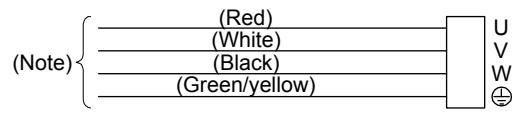

Note. These are not shielded cables.

5. WIRING OPTION

5.4 Electromagnetic brake cable

These cables are electromagnetic brake cables for the HG-KN series servo motors. The numbers in the cable length field of the table indicate the symbol filling the underline "_" in the cable model.

Refer to section 4.2.1 for wiring.

Cable model	Cable length				IP rating	Bending life	Application
	0.3 m	2 m	5 m	10 m			
MR-BKS1CBL_M-A1-L		2	5	10	IP65	Standard	Load-side lead for HG-KN servo motor
MR-BKS1CBL_M-A2-L		2	5	10	IP65	Standard	Opposite to load-side lead for HG-KN servo motor
MR-BKS1CBL_M-A1-H		2	5	10	IP65	Long bending life	Load-side lead for HG-KN servo motor
MR-BKS1CBL_M-A2-H		2	5	10	IP65	Long bending life	Opposite to load-side lead for HG-KN servo motor
MR-BKS2CBL03M-A1-L	03				IP55	Standard	Load-side lead for HG-KN servo motor
MR-BKS2CBL03M-A2-L	03				IP55	Standard	Opposite to load-side lead for HG-KN servo motor

(1) Connection of power supply for electromagnetic brake and servo motor

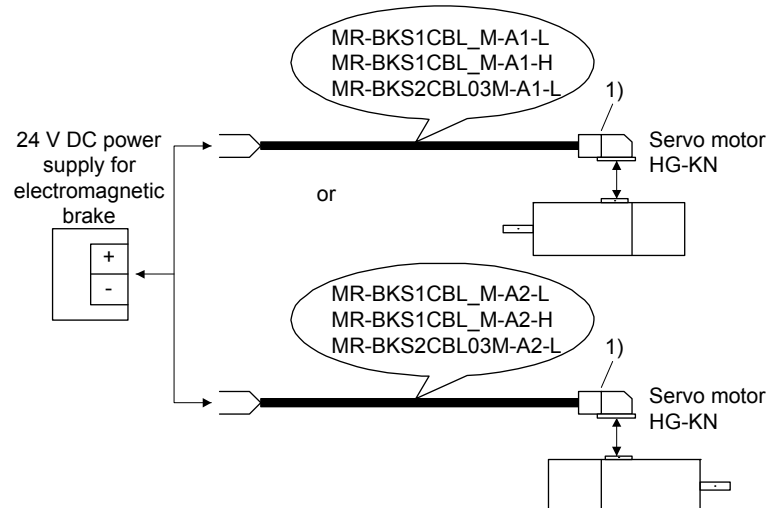

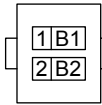
Cable model	1) Connector for electromagnetic brake	
MR-BKS1CBL_M-A1-L	Connector: JN4FT02SJ1-R Hood, socket insulator Bushing, ground nut Contact: ST-TMH-S-C1B-100-(A534G) Crimping tool: CT170-14-TMH5B (JAE)	 View seen from wiring side.
MR-BKS1CBL_M-A2-L		
MR-BKS1CBL_M-A1-H		
MR-BKS1CBL_M-A2-H		
MR-BKS2CBL03M-A1-L	Connector: JN4FT02SJ2-R Hood, socket insulator Bushing, ground nut Contact: ST-TMH-S-C1B-100-(A534G) Crimping tool: CT170-14-TMH5B (JAE)	
MR-BKS2CBL03M-A2-L		

(2) Internal wiring diagram

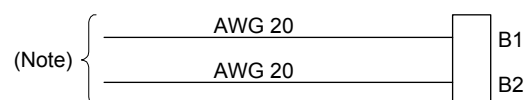

Note. These are not shielded cables.

5. WIRING OPTION

5.5 Wires for option cables

When fabricating a cable, use the wire models given in the following table or equivalent.

Table 5.1 Wires for option cables

Type	Model	Length [m]	Core size	Number of cores	Characteristics of one core			(Note 2) Cable OD [mm]	Wire model (Manufacturer)
					Structure [Wires/mm]	Conductor resistance [Ω /km]	(Note 1) Insulator OD [mm]		
Encoder cable	MR-J3ENCBL_M-A1-L	2 to 10	AWG 22	6 (3 pairs)	7/0.26	53 or less	1.18	7.1	(Note 3) VSVP 7/0.26 (AWG#22 or equivalent)-3P KB-1655-2 (Bando Densen)
	MR-J3ENCBL_M-A2-L								
	MR-J3ENCBL_M-A1-H	2 to 10	AWG 22	6 (3 pairs)	70/0.08	56 or less	1.17	7.1	(Note 3) TPE•SVP 70/0.08 (AWG#22 or equivalent)-3P KB-2237-2 (Bando Densen)
	MR-J3ENCBL_M-A2-H								
	MR-J3JCBL03M-A1-L	0.3	AWG 26	8 (4 pairs)	30/0.08	233 or less	1.2	7.1 \pm 0.3	T/2464-1061/IIA-SB 4P×26AWG (Taiyo Cabletec)
	MR-J3JCBL03M-A2-L								
	MR-EKCBL_M-L	2 to 10	AWG 28	4 (2 pairs)	7/0.127	232 or less	1.18	7.0	(Note 3) 20276 composite 6-core shielded cable Ban-gi-shi-16395-1 (Bando Densen)
			AWG 22	2	17/0.16	28.7 or less	1.50		
	MR-EKCBL_M-H	20 • 30	AWG 23	12 (6 pairs)	12/0.18	63.6 or less	1.2	8.2 \pm 0.3	(Note 3) 20276 VSVPAWG#23×6P KB-0492 (Bando Densen)
		2 to 10	0.2 mm ²	12 (6 pairs)	40/0.08	105 or less	0.88	7.2	(Note 3) A14B2343 6P (Junkosha)
		20	AWG 24	12 (6 pairs)	40/0.08	105 or less	0.88	7.2	(Note 3) TPE•SVP 40/0.08 (AWG#24 or equivalent)-6P KB-1928-2 (Bando Densen)
	MR-J3JSCBL03M-A1-L	0.3	AWG 26	8 (4 pairs)	7/0.16	146 or less	1.0	7.1 \pm 0.3	(Note 3) VSVP 7/0.16 (AWG#26 or equivalent)-4P Ban-gi-shi-16822 (Bando Densen)
	MR-J3ENSCBL_M-L	2 to 10	AWG 22	6 (3 pairs)	7/0.26	53 or less	1.18	7.1	(Note 3) VSVP 7/0.26 (AWG#22 or equivalent)-3P KB-1655-2 (Bando Densen)
		20 • 30	AWG 23	12 (6 pairs)	12/0.18	63.3 or less	1.2	8.2 \pm 0.3	(Note 3) 20276 VSVPAWG#23×6P KB-0492 (Bando Densen)
	MR-J3ENSCBL_M-H	2 to 10	AWG 22	6 (3 pairs)	70/0.08	56 or less	1.17	7.1	(Note 3) TPE•SVP 70/0.08 (AWG#22 or equivalent)-3P KB-2237-2 (Bando Densen)
20 to 50		AWG 24	12 (6 pairs)	40/0.08	105 or less	0.88	7.2	(Note 3) TPE•SVP 40/0.08 (AWG#24 or equivalent)-6P KB-1928-2 (Bando Densen)	

5. WIRING OPTION

Type	Model	Length [m]	Core size	Number of cores	Characteristics of one core			(Note 2) Cable OD [mm]	Wire model (Manufacturer)
					Structure [Wires/m m]	Conductor resistance [Ω /km]	(Note 1) Insulator OD d [mm]		
Servo motor power supply cable	MR-PWS1CBL_M-A1-L	2 to 10	AWG 18	4	34/0.18	21.8 or less	1.71	6.2 ± 0.3	(Note 4) HRZFEV-A(CL3) AWG 18 4 cores (Dyden)
	MR-PWS1CBL_M-A2-L	2 to 10							
	MR-PWS1CBL_M-A1-H	2 to 10	AWG 19 (0.75 mm ²)	4	150/0.08	29.1 or less	1.63	5.7 ± 0.5	(Note 4) RMFES-A(CL3X) AWG 19 4 cores (Dyden)
	MR-PWS1CBL_M-A2-H	2 to 10							
	MR-PWS2CBL03M-A1-L	0.3	AWG 19	4	30/0.18	25.8 or less	1.64	-	(Note 3, 5) J11B2330 UL10125 (Junkosha)
	MR-PWS2CBL03M-A2-L	0.3							
Electromagnetic brake cable	MR-BKS1CBL_M-A1-L	2 to 10	AWG 20	2	21/0.18	34.6 or less	1.35	4.7 ± 0.1	(Note 4) HRZFEV-A(CL3) AWG 20 2 cores (Dyden)
	MR-BKS1CBL_M-A2-L	2 to 10							
	MR-BKS1CBL_M-A1-H	2 to 10	AWG 20	2	110/0.08	39.0 or less	1.37	4.5 ± 0.3	(Note 4) RMFES-A(CL3X) AWG 20 2 cores (Dyden)
	MR-BKS1CBL_M-A2-H	2 to 10							
	MR-BKS2CBL03M-A1-L	0.3	AWG 20	2	19/0.203	32.0 or less	1.42	-	(Note 3, 5) J11B2331 UL10125 (Junkosha)
	MR-BKS2CBL03M-A2-L	0.3							

Note 1. The following shows the detail of d.

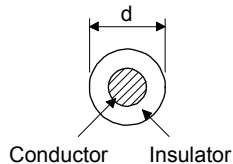

2. Standard OD. Maximum OD is about 10% greater.
3. Purchase from Toa Electric Industrial
4. Purchase from Taisei Co., Ltd.
5. These models consist with solid wires. Specify the color, separately.

6. HG-KN SERIES

6. HG-KN SERIES

This chapter provides information on the servo motor specifications and characteristics. When using the HG-KN series servo motor, always read the Safety Instructions in the beginning of this manual and chapters 1 to 5, in addition to this chapter.

6.1 Model designation

The following describes model designation. Not all combinations of the symbols are available.

H G - K N 1 3 B J D

Series

Rated output

Symbol	Rated output [kW]
1	0.1
2	0.2
4	0.4
7	0.75

Rated speed
3000 [r/min]

Electromagnetic brake

Symbol	Electromagnetic brake
None	None
B	With

Shaft type

Symbol	Shaft shape	HG-KN_
None	Standard (straight shaft)	13 to 73
K	Keyway shaft (with key)	23 to 73
D	D cut shaft	13

Oil seal

Symbol	Oil seal
None	None
J	With

Appearance

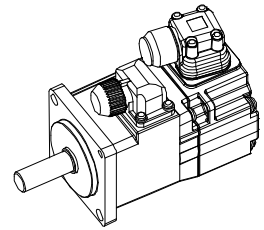

6.2 Combination list of servo motors and servo amplifiers

Servo motor	Servo amplifier
HG-KN13	MR-JE-10A
	MR-JE-10B(F)
	MR-JE-10C
HG-KN23	MR-JE-20A
	MR-JE-20B(F)
	MR-JE-20C
HG-KN43	MR-JE-40A
	MR-JE-40B(F)
	MR-JE-40C
HG-KN73	MR-JE-70A
	MR-JE-70B(F)
	MR-JE-70C

6. HG-KN SERIES

6.3 Standard specifications

6.3.1 Standard specifications list

Item		Servo motor		HG-KN series (low inertia/small capacity)			
				13(B)(J)	23(B)(J)	43(B)(J)	73(B)J
Power supply capacity		Refer to "Power supply equipment capacity and generated loss of servo amplifiers" in Servo Amplifier Instruction Manual.					
Continuous running duty (Note 1)	Rated output [kW]		0.1	0.2	0.4	0.75	
	Rated torque [N•m]		0.32	0.64	1.3	2.4	
Maximum torque [N•m]			0.95	1.9	3.8	7.2	
Rated speed (Note 1) [r/min]			3000				
Maximum speed [r/min]			5000 (6000) (Note 9)				
Instantaneous permissible speed [r/min]			5750 (6900) (Note 9)				
Power rate at continuous rated torque	Standard [kW/s]		12.9	18.0	43.2	44.5	
	With an electromagnetic brake [kW/s]		12.0	16.4	40.8	41.0	
Rated current [A]			0.8	1.3	2.6	4.8	
Maximum current [A]			2.4	3.9	7.8	14	
Moment of inertia J	Standard [$\times 10^{-4}$ kg•m ²]		0.0783	0.225	0.375	1.28	
	With an electromagnetic brake [$\times 10^{-4}$ kg•m ²]		0.0843	0.247	0.397	1.39	
Recommended load to motor inertia ratio (Note 2)			15 times or less				
Speed/position detector	Combination with MR-JE-_B(F)/MR-JE-_C		17-bit encoder common to absolute position/incremental systems (resolution per servo motor revolution: 131072 pulses/rev)				
	Combination with MR-JE-_A		Incremental 17-bit encoder system (resolution per servo motor revolution: 131072 pulses/rev)				
Oil seal	With		○				
	None		○				
Thermistor			None				
Insulation class			130 (B) (Note 8)				
Structure			Totally enclosed, natural cooling (IP rating: IP65 (Note 3))				
Environment (Note 4)	Ambient temperature	Operation	0 °C to 40 °C (non-freezing)				
		Storage	-15 °C to 70 °C (non-freezing)				
	Ambient humidity	Operation	10 %RH to 80 %RH (non-condensing)				
		Storage	10 %RH to 90 %RH (non-condensing)				
	Ambience			Indoors (no direct sunlight), free from corrosive gas, flammable gas, oil mist, dust, and dirt			
	Altitude			Max. 2000 m above sea level (Note 10)			
Vibration resistance (Note 5)			X, Y: 49 m/s ²				
Vibration rank (Note 6)			V10				
Permissible load for the shaft (Note 7)	L [mm]		25	30	40		
	Radial [N]		88	245	392		
	Thrust [N]		59	98	147		
Mass	With oil seal	Standard [kg]	0.57	0.98	1.5	3.0	
		With an electromagnetic brake [kg]	0.77	1.4	1.9	4.0	
	Without oil seal	Standard [kg]	0.54	0.91	1.4		
		With an electromagnetic brake [kg]	0.74	1.3	1.8		

6. HG-KN SERIES

- Note
1. When the power supply voltage drops, the output and the rated speed cannot be guaranteed.
 2. If the load to motor inertia ratio exceeds the indicated value, contact your local sales office.
 3. Except for the shaft-through portion. IP classifies the degrees of protection provided against the intrusion of solid objects and water in electrical enclosures.
 4. In the environment where the servo motor is exposed to oil mist, oil, or water, the servo motor of the standard specifications may not be usable. Please contact your local sales office.
 5. The following figure shows the vibration directions. The value is the one at the part that indicates the maximum value (normally the opposite to load-side bracket). When the servo motor stops, fretting is likely to occur at the bearing. Therefore, suppress the vibration to about half of the permissible value.

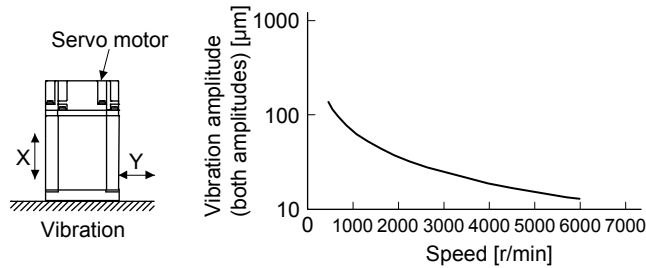

6. V10 indicates that the amplitude of a single servo motor is 10 μm or less. The following figure shows the servo motor mounting position for measurement and the measuring position.

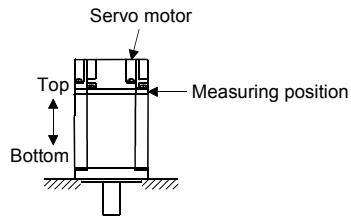

7. The following shows permissible load for the shaft. Do not subject the shaft to load greater than the value in the specifications list. The value assumes that the load is applied independently.

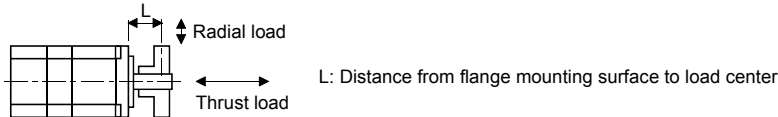

8. When you conform HG-KN series servo motor to the UL/CSA standard as a certified product by UL, the insulation class will be 105 (A). The insulation class is approved for 130 (B) as for the UL/CSA standard by TÜV Rheinland.
9. Values in parentheses are applicable according to the parameter setting of the servo amplifier. For details, refer to each servo amplifier instruction manual.
10. Follow the restrictions in section 2.11 when using the servo amplifiers at altitude exceeding 1000 m and up to 2000 m above sea level.

6. HG-KN SERIES

6.3.2 Torque characteristics

POINT

- For the system where the unbalanced torque occurs, such as a vertical axis system, the unbalanced torque of the machine should be kept at 70% or lower of the motor's rated torque.

When the power supply input of the servo amplifier is 3-phase 200 V AC or 1-phase 230 V AC, the torque characteristic is indicated by the heavy line.

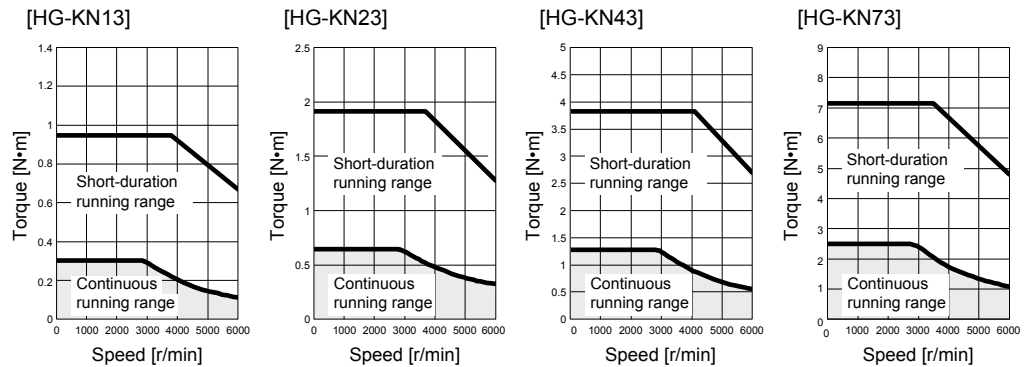

6. HG-KN SERIES

6.4 Electromagnetic brake characteristics

 CAUTION	<ul style="list-style-type: none"> ● The electromagnetic brake is provided to prevent a drop at a power failure or alarm occurrence during vertical drive or to hold a shaft at a stop. Do not use it for normal braking (including braking at servo-lock).
	<ul style="list-style-type: none"> ● Before operating the servo motor, be sure to confirm that the electromagnetic brake operates properly.
	<ul style="list-style-type: none"> ● The operation time of the electromagnetic brake varies depending on the power supply circuit you use. Be sure to check the operation delay time with a real machine.

The characteristics of the electromagnetic brake provided for the servo motor with an electromagnetic brake are indicated below.

Item		Servo motor	HG-KN series			
			13B(J)	23B(J)	43B(J)	73BJ
Type (Note 1)		Spring actuated type safety brake				
Rated voltage (Note 4)		24 V DC ⁰ / _{-10%}				
Power consumption [W] at 20 °C		6.3	7.9	10		
Coil resistance (Note 6) [Ω]		91.0	73.0	57.0		
Inductance (Note 6) [H]		0.15	0.18	0.13		
Brake static friction torque (Note 9) [N·m]		0.32 or more	1.3 or more	2.4 or more		
Release delay time (Note 2) [s]		0.03	0.03	0.04		
Braking delay time (Note 2) [s]		DC off	0.01	0.02	0.02	
Permissible braking work		Per braking [J]	5.6	22	64	
		Per hour [J]	56	220	640	
Brake looseness at servo motor shaft (Note 5) [degree]		2.5	1.2	0.9		
Brake life (Note 3)		Number of braking cycles [times]	20000			
		Work per braking [J]	5.6	22	64	
Selection example of surge absorbers to be used (Note 7, 8)		For the suppressed voltage 125 V	TND20V-680KB			
		For the suppressed voltage 350 V	TND10V-221KB			

- Note
1. It does not have a manual release mechanism. When it is necessary to hand-turn the servo motor shaft for machine centering, etc., use a separate 24 V DC power supply to release the brake electrically.
 2. The value for initial on gap at 20 °C.
 3. The brake gap will increase as the brake lining wears, but the gap is not adjustable. The brake life indicated is the number of braking cycles after which adjustment will be required.
 4. Always prepare a power supply exclusively used for the electromagnetic brake.
 5. These are design values. These are not guaranteed values.
 6. These are measured values. These are not guaranteed values.
 7. Select the electromagnetic brake control relay properly, considering the characteristics of the electromagnetic brake and surge absorber. When you use a diode for a surge absorber, the electromagnetic braking time will be longer.
 8. Manufactured by Nippon Chemi-Con Corporation.
 9. The value of the brake static friction torque is the lower limit in the initial state at 20 °C.

6. HG-KN SERIES

6.5 Servo motors with special shafts

The servo motors with special shafts indicated by the symbols (K/D) in the table are available. K and D are the symbols included in the servo motor model names.

Servo motor	Shaft shape	
	Key shaft (with key)	D cut shaft
HG-KN13(B)(J)_	K	D
HG-KN23(B)(J)_		
HG-KN43(B)(J)_		
HG-KN73(B)(J)_		

6.5.1 Key shaft (with 2 round end key)

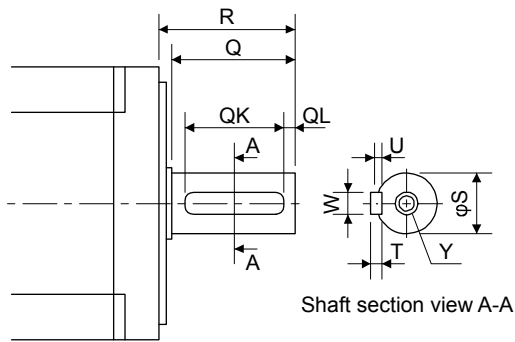

Servo motor	Variable dimensions								
	S	R	Q	W	QK	QL	U	T	Y
HG-KN23(B)(J)K HG-KN43(B)(J)K	14h6	30	27	5	20	3	3	5	M4 Screw hole depth 15
HG-KN73(B)JK	19h6	40	37	6	25	5	3.5	6	M5 Screw hole depth 20

6.5.2 D cut shaft

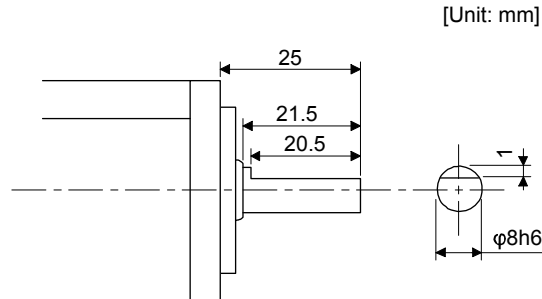

6. HG-KN SERIES

6.6 Servo motor with oil seal

The oil seal prevents the entry of oil into the servo motor.

Install the servo motor horizontally, and set the oil level in the gear box to be lower than the oil seal lip always.

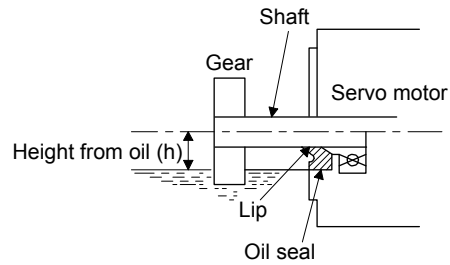

Servo motor	Height (h) from the surface of the oil [mm]
HG-KN13(B)J	10
HG-KN23(B)J HG-KN43(B)J HG-KN73(B)J	19

6. HG-KN SERIES

6.7 Mounting connectors

If the connector is not fixed securely, it may come off or may not produce a splash-proof effect during operation.

To achieve the IP rating IP65, pay attention to the following points and install the connectors.

- (1) When screwing the connector, hold the connector still and gradually tighten the screws in a crisscross pattern.

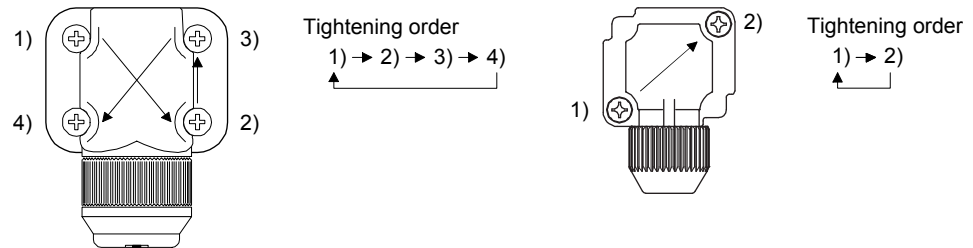

Connector for power, connector for encoder Connector for electromagnetic brake

- (2) Tighten the screws evenly. Tightening torques are as indicated below.

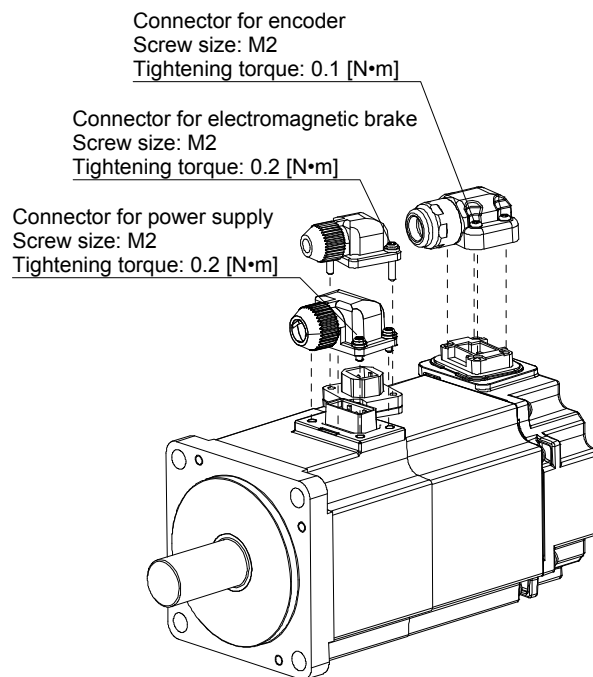

- (3) The servo motor fitting part of each connector is provided with a splash-proof seal (O ring). When mounting a connector, use care to prevent the seal (O ring) from dropping and being pinched. If the seal (O ring) has dropped or is pinched, a splash-proof effect is not produced.

6. HG-KN SERIES

6.8 Dimensions

Moment of inertia on the table is the value calculated by converting the total value of moment of inertia for servo motor and electromagnetic brake with servo motor shaft.

When running the cables to the load side, take care to avoid interference with the machine. The dimensions without tolerances are general tolerance.

6.8.1 Standard (without an electromagnetic brake)

(1) With oil seal

Model	Output [W]	Moment of inertia J [$\times 10^{-4}$ kg·m ²]	Mass [kg]
HG-KN13J	100	0.0783	0.57

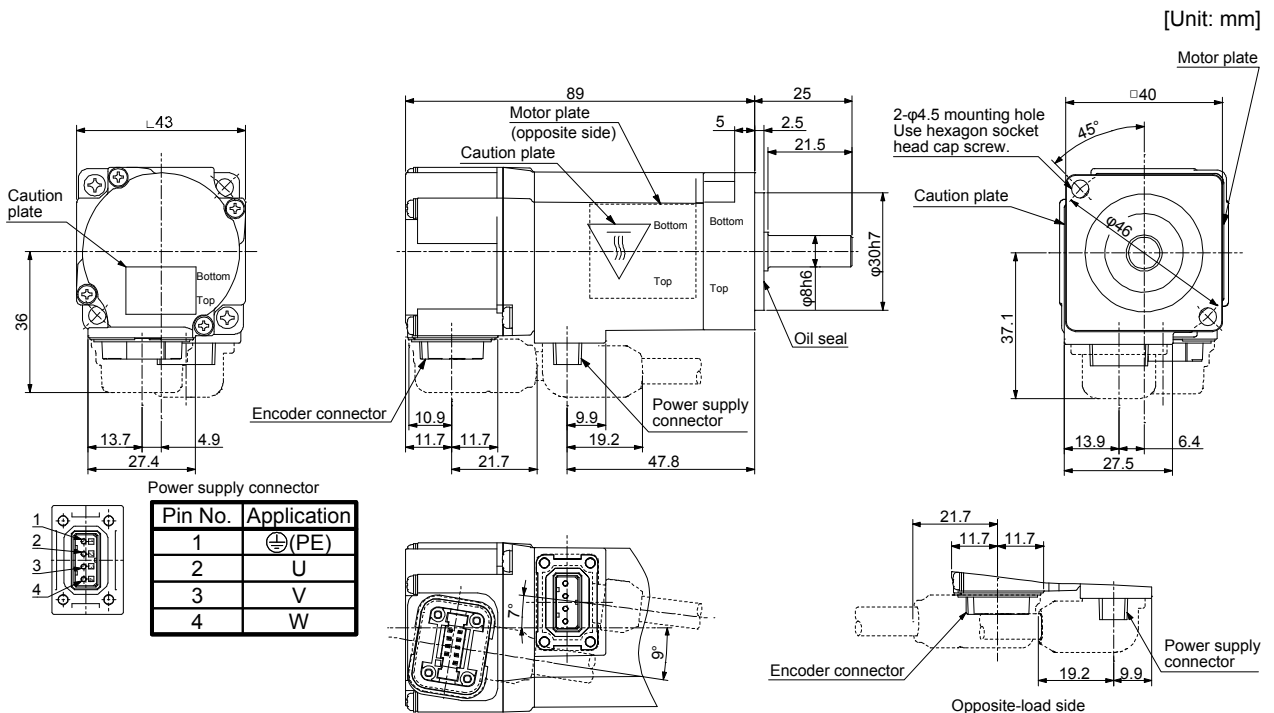

BC43583*

6. HG-KN SERIES

Model	Output [W]	Moment of inertia J [$\times 10^{-4}$ kg·m ²]	Mass [kg]
HG-KN23J	200	0.225	0.98

[Unit: mm]

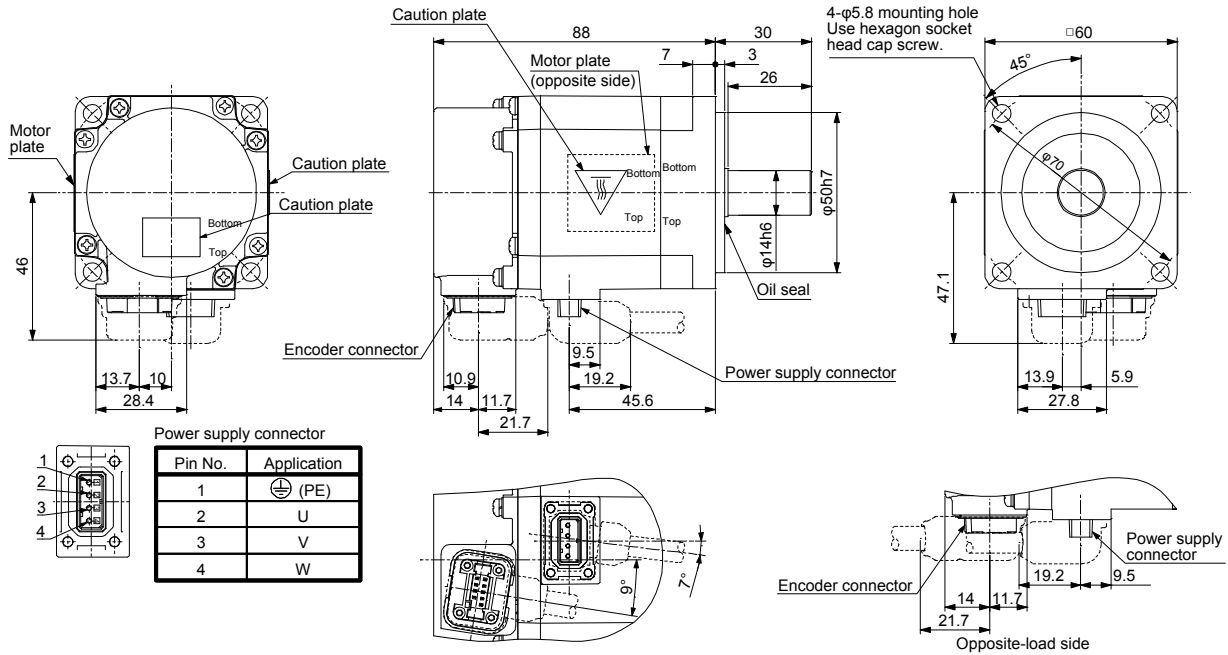

BC43584*

Model	Output [W]	Moment of inertia J [$\times 10^{-4}$ kg·m ²]	Mass [kg]
HG-KN43J	400	0.375	1.5

[Unit: mm]

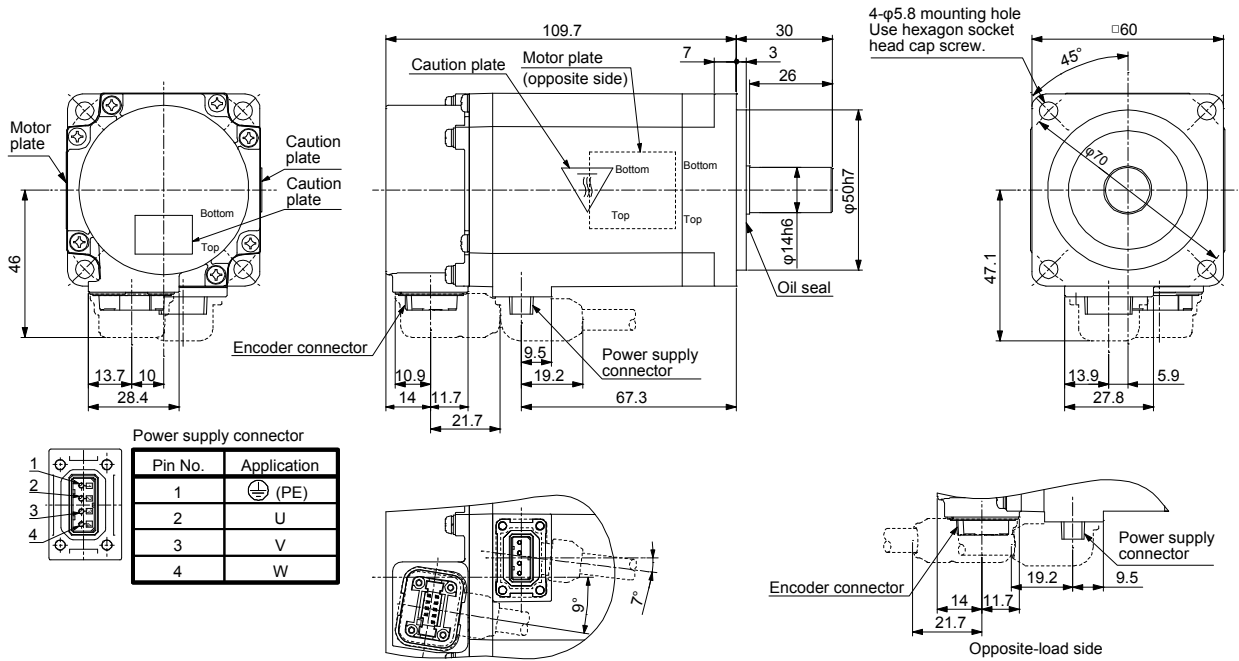

BC43585*

6. HG-KN SERIES

Model	Output [W]	Moment of inertia J [$\times 10^{-4}$ kg·m ²]	Mass [kg]
HG-KN73J	750	1.28	3.0

[Unit: mm]

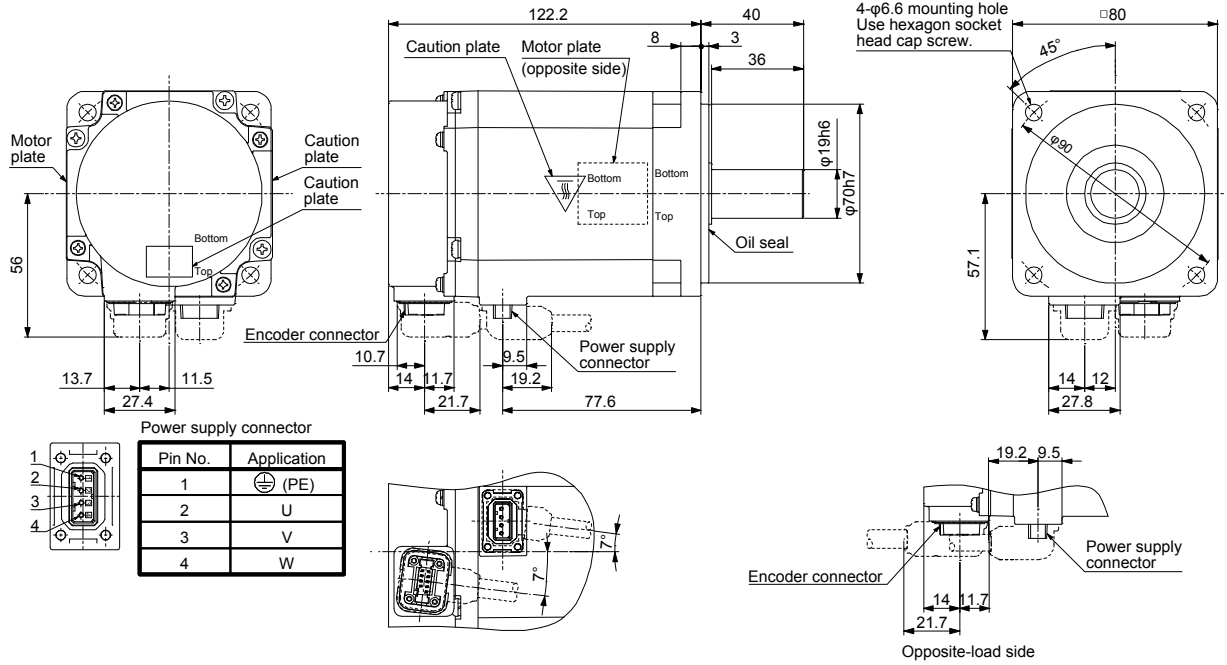

BC43586*

(2) Without oil seal

Model	Output [W]	Moment of inertia J [$\times 10^{-4}$ kg·m ²]	Mass [kg]
HG-KN13	100	0.0777	0.54

[Unit: mm]

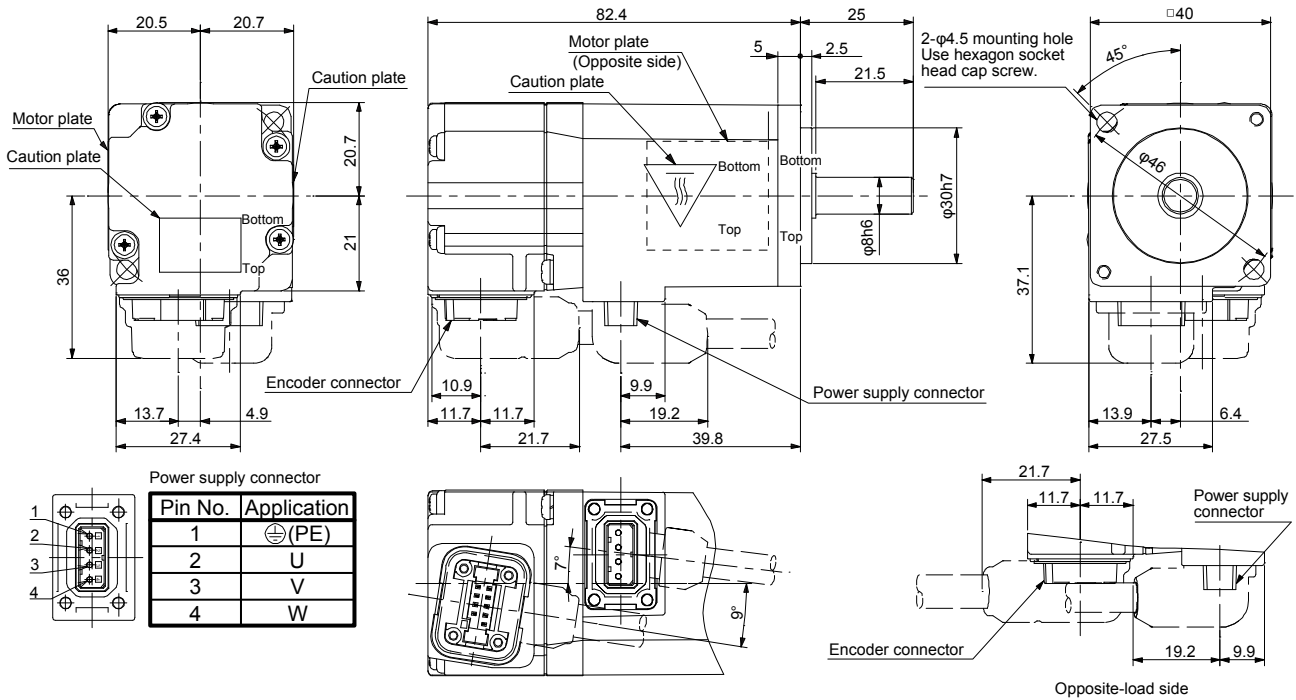

BC43576*

6. HG-KN SERIES

6.8.2 With an electromagnetic brake

(1) With oil seal

Model	Output [W]	Brake static friction torque [N·m]	Moment of inertia J [$\times 10^{-4}$ kg·m ²]	Mass [kg]
HG-KN13BJ	100	0.32	0.0843	0.77

[Unit: mm]

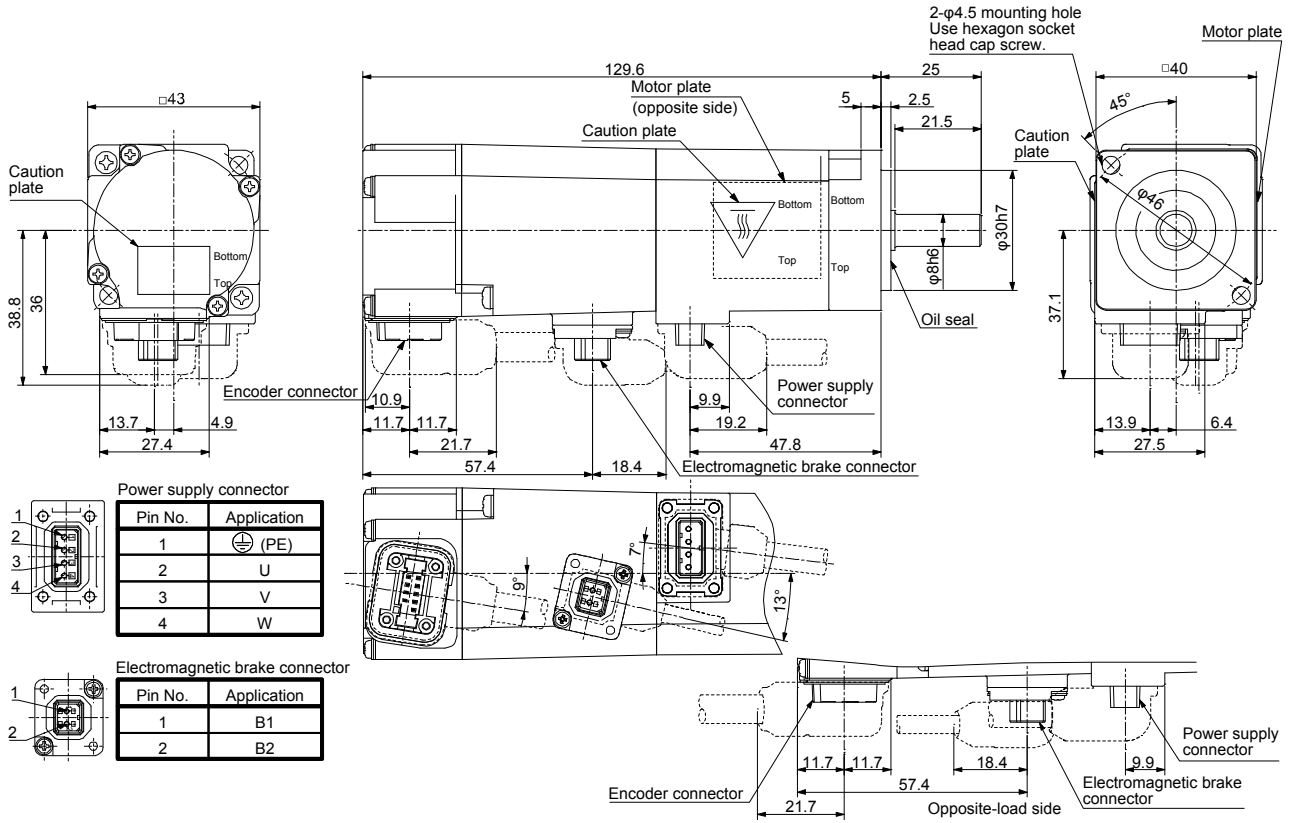

BC43587*

6. HG-KN SERIES

Model	Output [W]	Brake static friction torque [N·m]	Moment of inertia J [$\times 10^{-4}$ kg·m ²]	Mass [kg]
HG-KN23BJ	200	1.3	0.247	1.4

[Unit: mm]

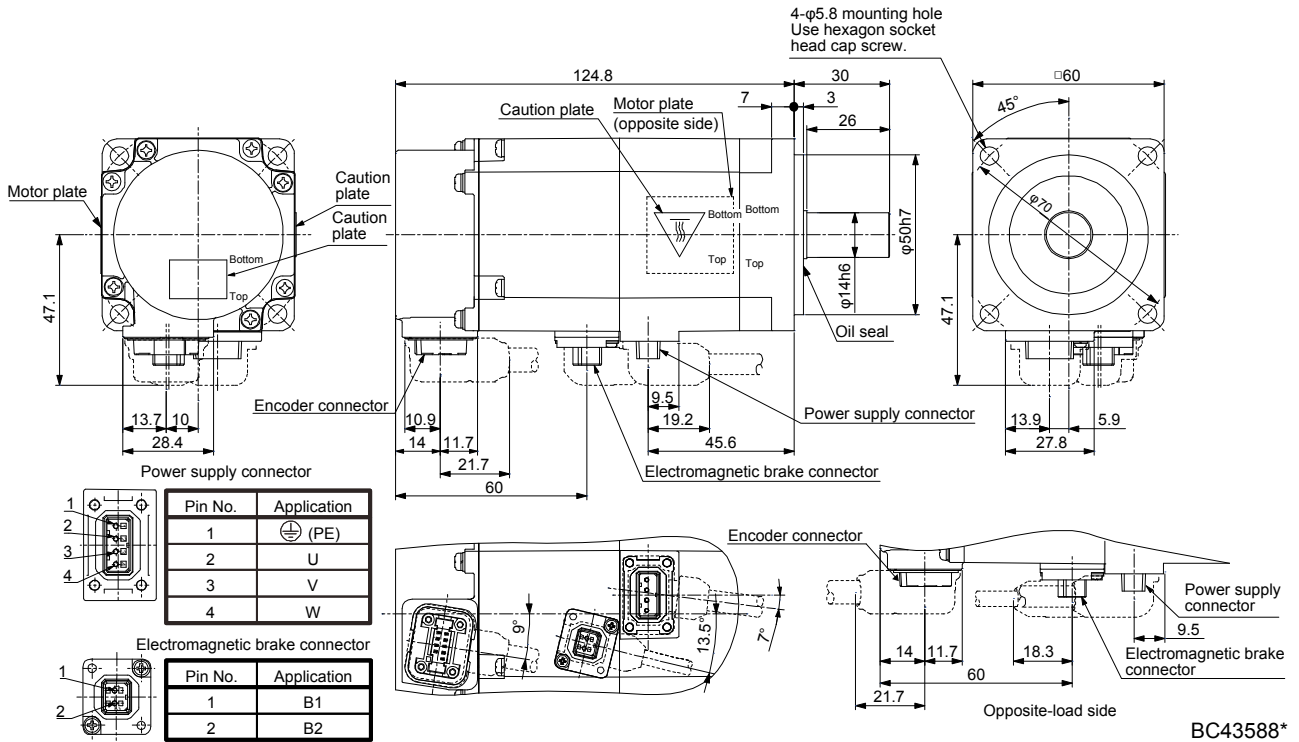

Model	Output [W]	Brake static friction torque [N·m]	Moment of inertia J [$\times 10^{-4}$ kg·m ²]	Mass [kg]
HG-KN43BJ	400	1.3	0.397	1.9

[Unit: mm]

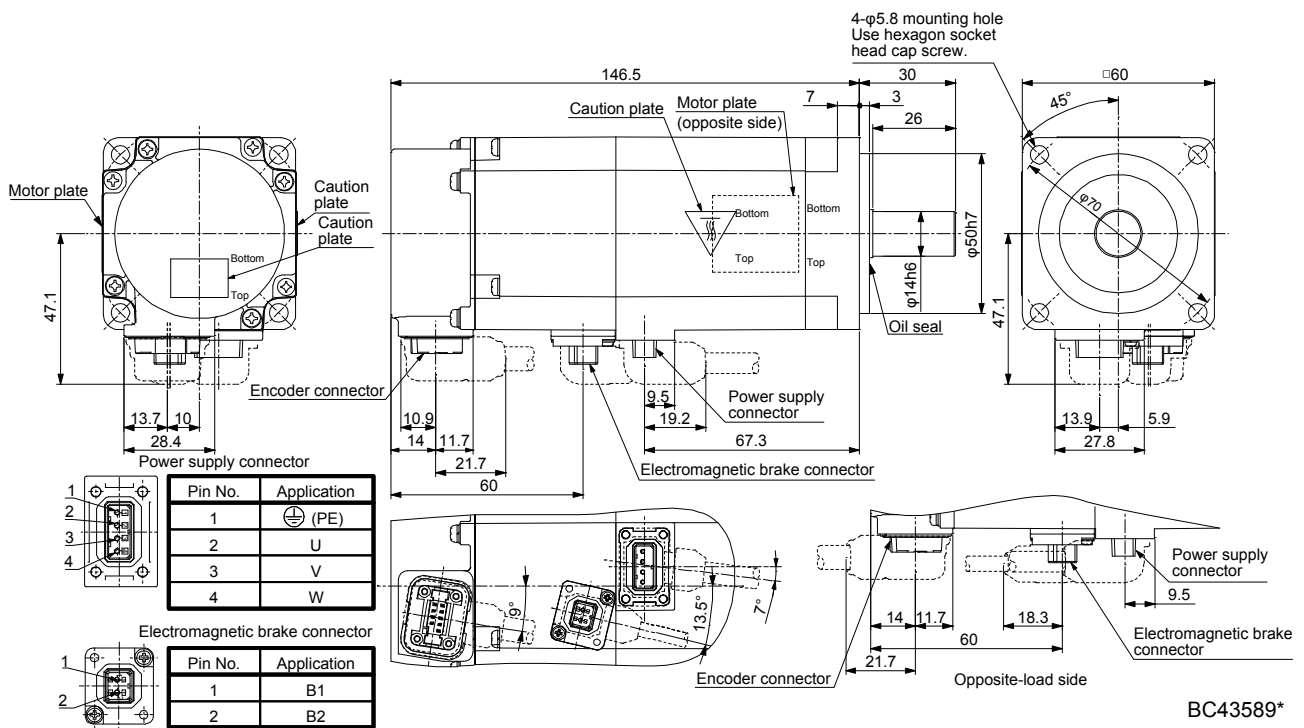

6. HG-KN SERIES

Model	Output [W]	Brake static friction torque [N·m]	Moment of inertia J [$\times 10^{-4}$ kg·m ²]	Mass [kg]
HG-KN73BJ	750	2.4	1.39	4.0

[Unit: mm]

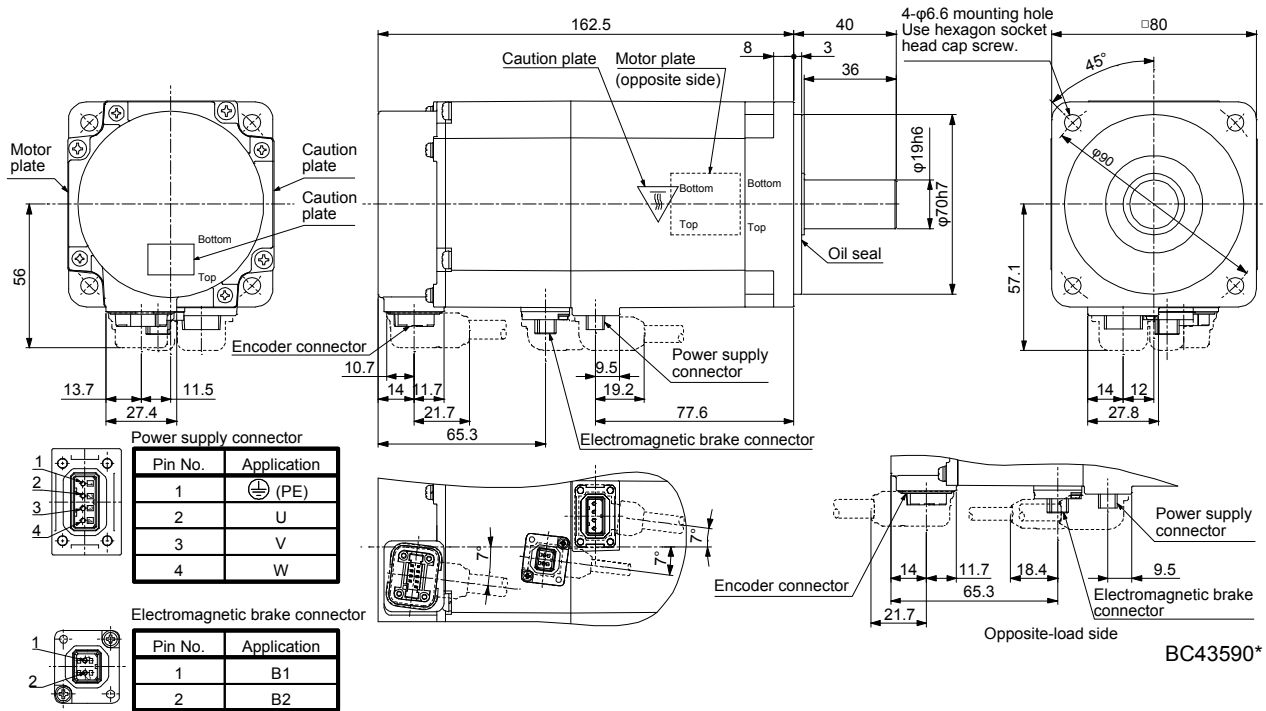

6. HG-KN SERIES

(2) Without oil seal

Model	Output [W]	Brake static friction torque [N·m]	Moment of inertia J [$\times 10^{-4}$ kg·m ²]	Mass [kg]
HG-KN13B	100	0.32	0.0837	0.74

[Unit: mm]

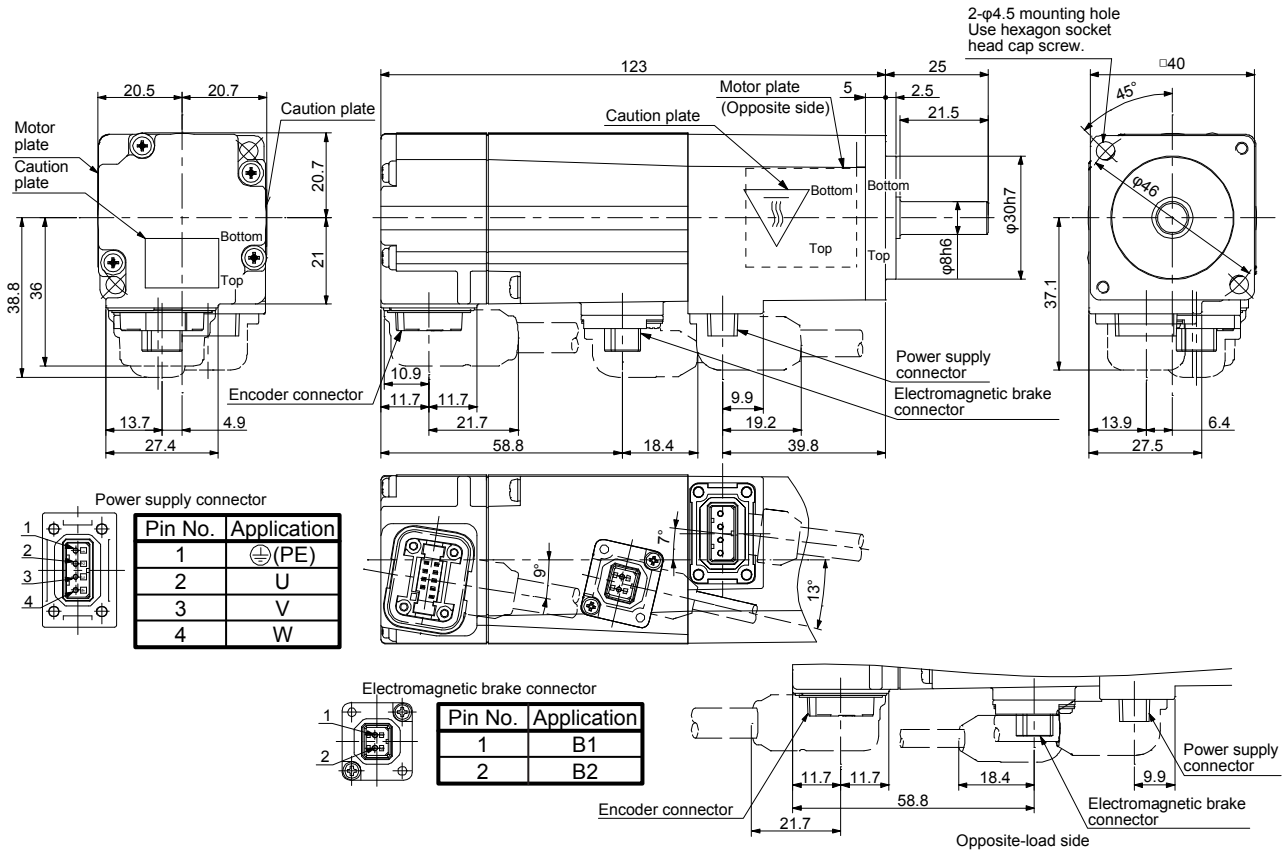

BC43580*

7. HG-SN SERIES

7. HG-SN SERIES

This chapter provides information on the servo motor specifications and characteristics. When using the HG-SN series servo motor, always read the Safety Instructions in the beginning of this manual and chapters 1 to 5, in addition to this chapter.

7.1 Model designation

The following describes model designation. Not all combinations of the symbols are available.

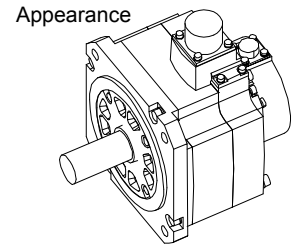
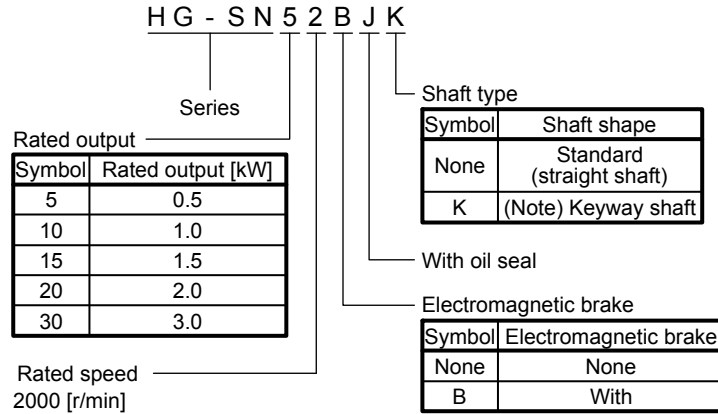

Note. Key is not included.

7.2 Combination list of servo motors and servo amplifiers

Servo motor	Servo amplifier
HG-SN52	MR-JE-70A MR-JE-70B(F) MR-JE-70C
HG-SN102	MR-JE-100A MR-JE-100B(F) MR-JE-100C
HG-SN152	MR-JE-200A
HG-SN202	MR-JE-200B(F) MR-JE-200C
HG-SN302	MR-JE-300A MR-JE-300B(F) MR-JE-300C

7. HG-SN SERIES

7.3 Standard specifications

7.3.1 Standard specifications list

Item		Servo motor	HG-SN series (3-phase 200 V AC compatible, medium inertia/medium capacity)				
			52(B)J	102(B)J	152(B)J	202(B)J	302(B)J
Power supply capacity		Refer to "Power supply equipment capacity and generated loss of servo amplifiers" in Servo Amplifier Instruction Manual.					
Continuous running duty (Note 1)	Rated output [kW]	0.5	1.0	1.5	2.0	3.0	
	Rated torque [N•m]	2.39	4.77	7.16	9.55	14.3	
Maximum torque [N•m]		7.16	14.3	21.5	28.6	42.9	
Rated speed (Note 1) [r/min]		2000					
Maximum speed [r/min]		3000				2500	
Instantaneous permissible speed [r/min]		3450				2875	
Power rate at continuous rated torque	Standard [kW/s]	7.85	19.7	32.1	19.5	26.1	
	With an electromagnetic brake [kW/s]	6.01	16.5	28.2	16.1	23.3	
Rated current [A]		2.9	5.6	9.4	9.6	11	
Maximum current [A]		9.0	17	29	31	33	
Moment of inertia J	Standard [$\times 10^{-4}$ kg•m ²]	7.26	11.6	16.0	46.8	78.6	
	With an electromagnetic brake [$\times 10^{-4}$ kg•m ²]	9.48	13.8	18.2	56.5	88.2	
Recommended load to motor inertia ratio (Note 2)		15 times or less					
Speed/position detector	Combination with MR-JE-_B(F)/MR-JE-_C	17-bit encoder common to absolute position/incremental systems (resolution per servo motor revolution: 131072 pulses/rev)					
	Combination with MR-JE-_A	Incremental 17-bit encoder system (resolution per servo motor revolution: 131072 pulses/rev)					
Oil seal		With					
Thermistor		None					
Insulation class		155 (F)					
Structure		Totally enclosed, natural cooling (IP rating: IP67 (Note 3))					
Environment (Note 4)	Ambient temperature	Operation	0 °C to 40 °C (non-freezing)				
		Storage	-15 °C to 70 °C (non-freezing)				
	Ambient humidity	Operation	10 %RH to 80 %RH (non-condensing)				
		Storage	10 %RH to 90 %RH (non-condensing)				
	Ambience		Indoors (no direct sunlight), free from corrosive gas, flammable gas, oil mist, dust, and dirt				
	Altitude		Max. 2000 m above sea level (Note 8)				
Vibration resistance (Note 5)		X, Y: 24.5 m/s ²			X: 24.5 m/s ² Y: 49 m/s ²		
Vibration rank (Note 6)		V10					
Permissible load for the shaft (Note 7)	L [mm]	55			79		
	Radial [N]	980			2058		
	Thrust [N]	490			980		
Mass	Standard [kg]	4.8	6.2	7.3	11	16	
	With an electromagnetic brake [kg]	6.7	8.2	9.3	17	22	

7. HG-SN SERIES

- Note
1. When the power supply voltage drops, the output and the rated speed cannot be guaranteed.
 2. If the load to motor inertia ratio exceeds the indicated value, contact your local sales office.
 3. Except for the shaft-through portion. IP classifies the degrees of protection provided against the intrusion of solid objects and water in electrical enclosures.
 4. In the environment where the servo motor is exposed to oil mist, oil, or water, the servo motor of the standard specifications may not be usable. Please contact your local sales office.
 5. The following figure shows the vibration directions. The value is the one at the part that indicates the maximum value (normally the opposite to load-side bracket). When the servo motor stops, fretting is likely to occur at the bearing. Therefore, suppress the vibration to about half of the permissible value.

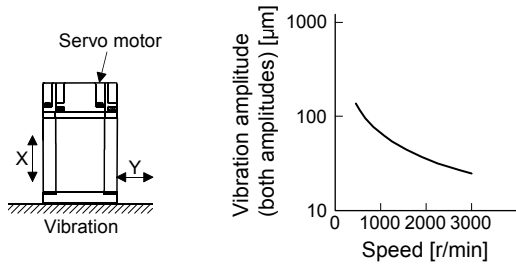

6. V10 indicates that the amplitude of a single servo motor is 10 μm or less. The following figure shows the servo motor mounting position for measurement and the measuring position.

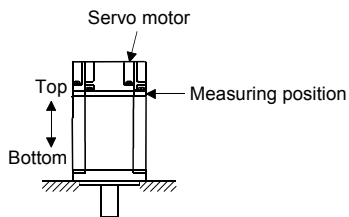

7. The following shows permissible load for the shaft. Do not subject the shaft to load greater than the value in the specifications list. The value assumes that the load is applied independently.

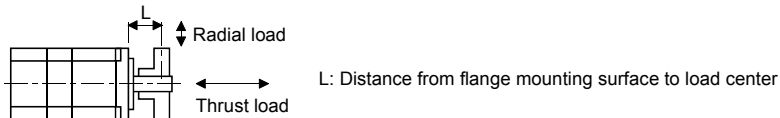

8. Follow the restrictions in section 2.11 when using the servo amplifiers at altitude exceeding 1000 m and up to 2000 m above sea level.

7. HG-SN SERIES

7.3.2 Torque characteristics

POINT

- For the system where the unbalanced torque occurs, such as a vertical axis system, the unbalanced torque of the machine should be kept at 70% or lower of the motor's rated torque.

When the power supply input of the servo amplifier is 3-phase 200 V AC or 1-phase 230 V AC, the torque characteristic is indicated by the heavy line. HG-SN52, HG-SN102, HG-SN152, and HG-SN202 support single-phase power supply.

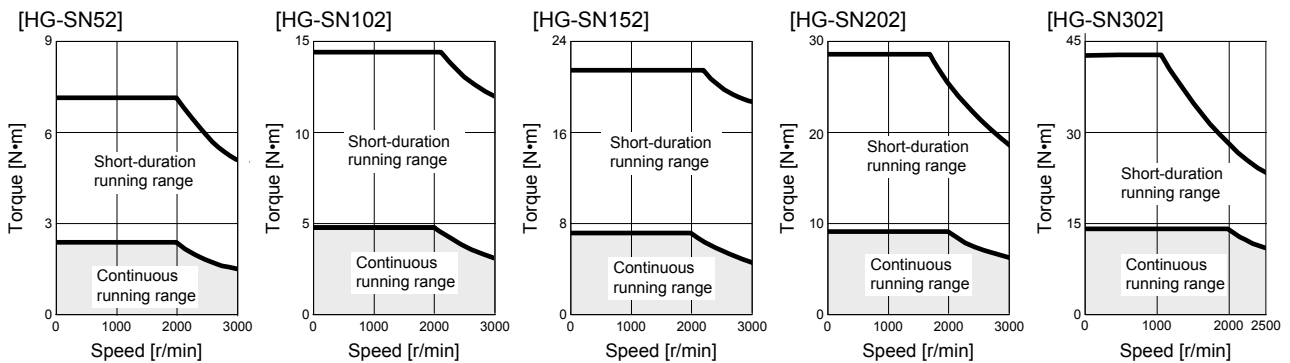

7. HG-SN SERIES

7.4 Electromagnetic brake characteristics

 CAUTION	<ul style="list-style-type: none"> ● The electromagnetic brake is provided to prevent a drop at a power failure or alarm occurrence during vertical drive or to hold a shaft at a stop. Do not use it for normal braking (including braking at servo-lock).
	<ul style="list-style-type: none"> ● Before operating the servo motor, be sure to confirm that the electromagnetic brake operates properly.
	<ul style="list-style-type: none"> ● The operation time of the electromagnetic brake varies depending on the power supply circuit you use. Be sure to check the operation delay time with a real machine.

The characteristics of the electromagnetic brake provided for the servo motor with an electromagnetic brake are indicated below.

Item	Servo motor	HG-SN series	
		52BJ/102BJ/152BJ	202BJ/302BJ
Type (Note 1)		Spring actuated type safety brake	
Rated voltage (Note 4)		24 V DC ⁰ / _{-10%}	
Power consumption	[W] at 20 °C	20	34
Coil resistance (Note 6)	[Ω]	29.0	16.8
Inductance (Note 6)	[H]	0.80	1.10
Brake static friction torque (Note 9)	[N·m]	8.5 or more	44 or more
Release delay time (Note 2)	[s]	0.04	0.1
Braking delay time (Note 2)	[s] DC off	0.03	0.03
Permissible braking work	Per braking [J]	400	4500
	Per hour [J]	4000	45000
Brake looseness at servo motor shaft (Note 5)	[degrees]	0.2 to 0.6	0.2 to 0.6
Brake life (Note 3)	Number of braking cycles [times]	20000	20000
	Work per braking [J]	200	1000
Selection example of surge absorbers to be used (Note 7, 8)	For the suppressed voltage 125 V	TND20V-680KB	
	For the suppressed voltage 350 V	TND10V-221KB	

Note 1. It does not have a manual release mechanism. When it is necessary to hand-turn the servo motor shaft for machine centering, etc., use a separate 24 V DC power supply to release the brake electrically.

2. The value for initial on gap at 20 °C.

3. The brake gap will increase as the brake lining wears, but the gap is not adjustable.

The brake life indicated is the number of braking cycles after which adjustment will be required.

4. Always prepare a power supply exclusively used for the electromagnetic brake.

5. These are design values. These are not guaranteed values.

6. These are measured values. These are not guaranteed values.

7. Select the electromagnetic brake control relay properly, considering the characteristics of the electromagnetic brake and surge absorber. When you use a diode for a surge absorber, the electromagnetic braking time will be longer.

8. Manufactured by Nippon Chemi-Con Corporation.

9. The value of the brake static friction torque is the lower limit in the initial state at 20 °C.

7. HG-SN SERIES

7.5 Servo motors with special shafts

The servo motors with special shafts indicated by the symbol (K) in the table are available. K is the symbol attached to the servo motor model names.

Servo motor	Shaft shape
	Key shaft (without key)
HG-SN_(B)JK	K

[Unit: mm]

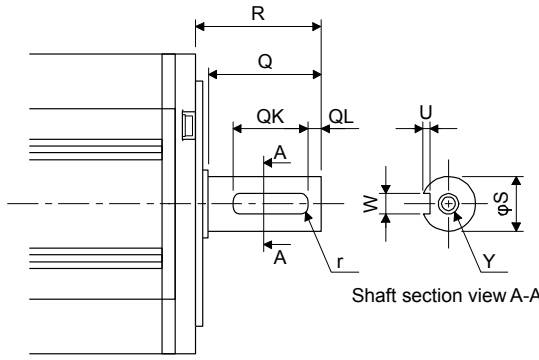

Servo motor	Variable dimensions								
	S	R	Q	W	QK	QL	U	r	Y
HG-SN52(B)JK HG-SN102(B)JK HG-SN152(B)JK	24h6	55	50	$8^{0}_{-0.036}$	36	5	$4^{+0.2}_{0}$	4	M8 Screw hole depth 20
HG-SN202(B)JK HG-SN302(B)JK	$35^{+0.010}_{0}$	79	75	$10^{0}_{-0.036}$	55	5	$5^{+0.2}_{0}$	5	M8 Screw hole depth 20

Key shaft (without key)

7.6 Servo motor with oil seal

The oil seal prevents the entry of oil into the servo motor.

Install the servo motor horizontally, and set the oil level in the gear box to be lower than the oil seal lip always.

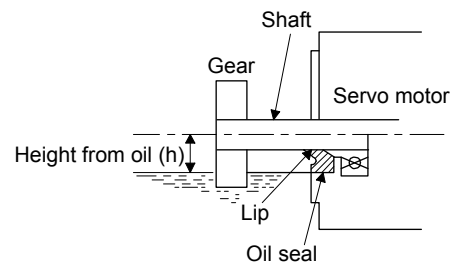

Servo motor	Height (h) from the surface of the oil [mm]
HG-SN52(B)J HG-SN102(B)J HG-SN152(B)J	23
HG-SN202(B)J HG-SN302(B)J	31

7. HG-SN SERIES

7.7 Dimensions

Moment of inertia on the table is the value calculated by converting the total value of moment of inertia for servo motor and electromagnetic brake with servo motor shaft.

The dimensions without tolerances are general tolerance.

7.7.1 Standard (without an electromagnetic brake)

Model	Output [kW]	Moment of inertia J [$\times 10^{-4}$ kg·m ²]	Mass [kg]
HG-SN52J	0.5	7.26	4.8

[Unit: mm]

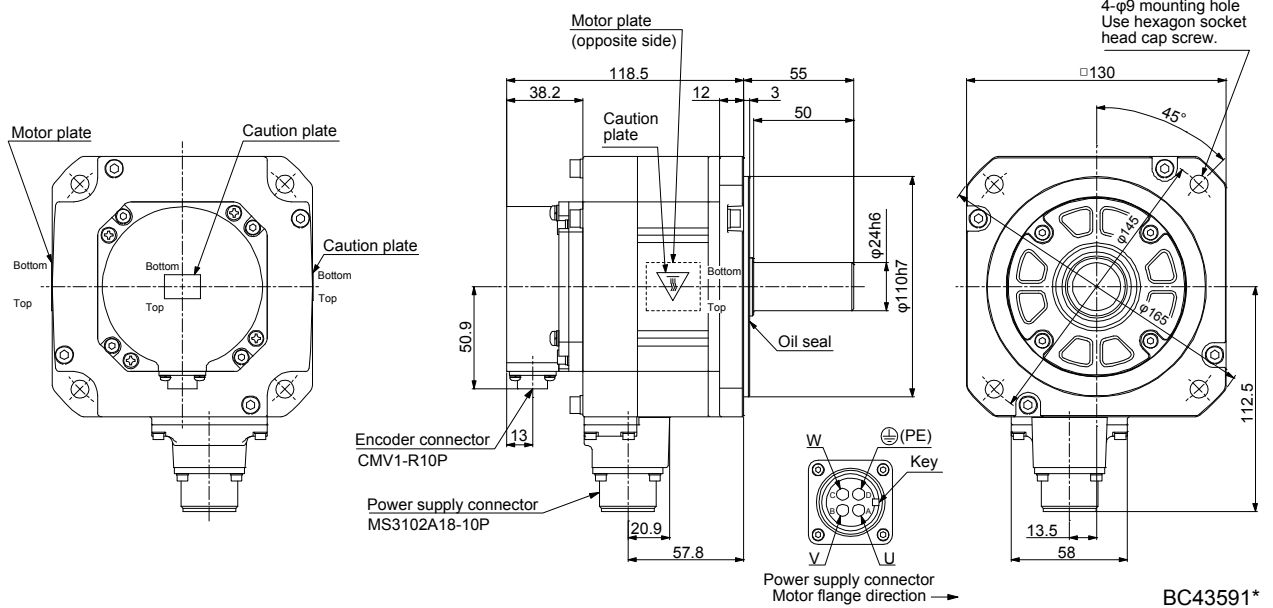

BC43591*

Model	Output [kW]	Moment of inertia J [$\times 10^{-4}$ kg·m ²]	Mass [kg]
HG-SN102J	1.0	11.6	6.2

[Unit: mm]

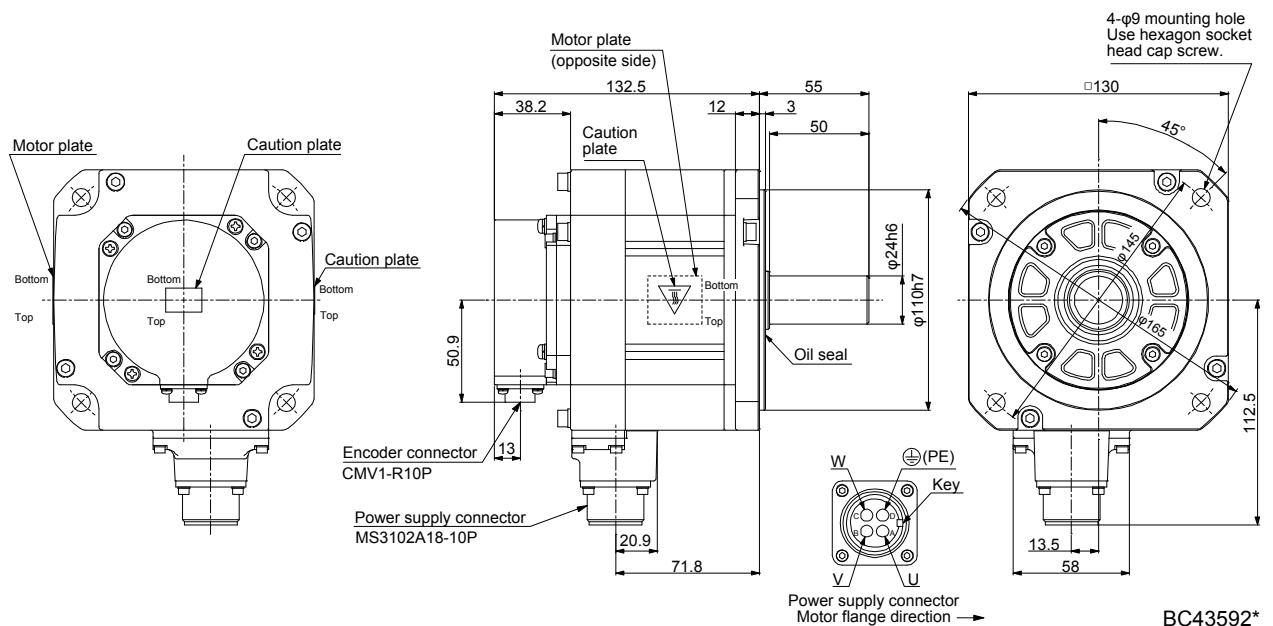

BC43592*

7. HG-SN SERIES

Model	Output [kW]	Moment of inertia J [$\times 10^{-4}$ kg·m ²]	Mass [kg]
HG-SN152J	1.5	16.0	7.3

[Unit: mm]

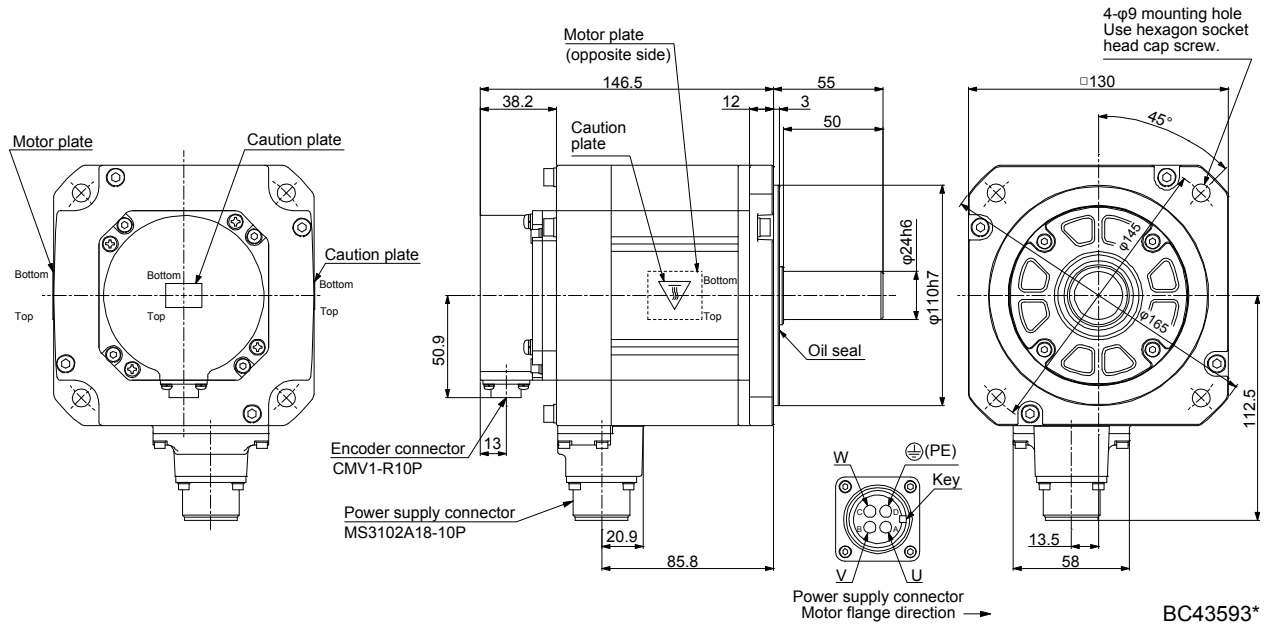

Model	Output [kW]	Moment of inertia J [$\times 10^{-4}$ kg·m ²]	Mass [kg]
HG-SN202J	2.0	46.8	11

[Unit: mm]

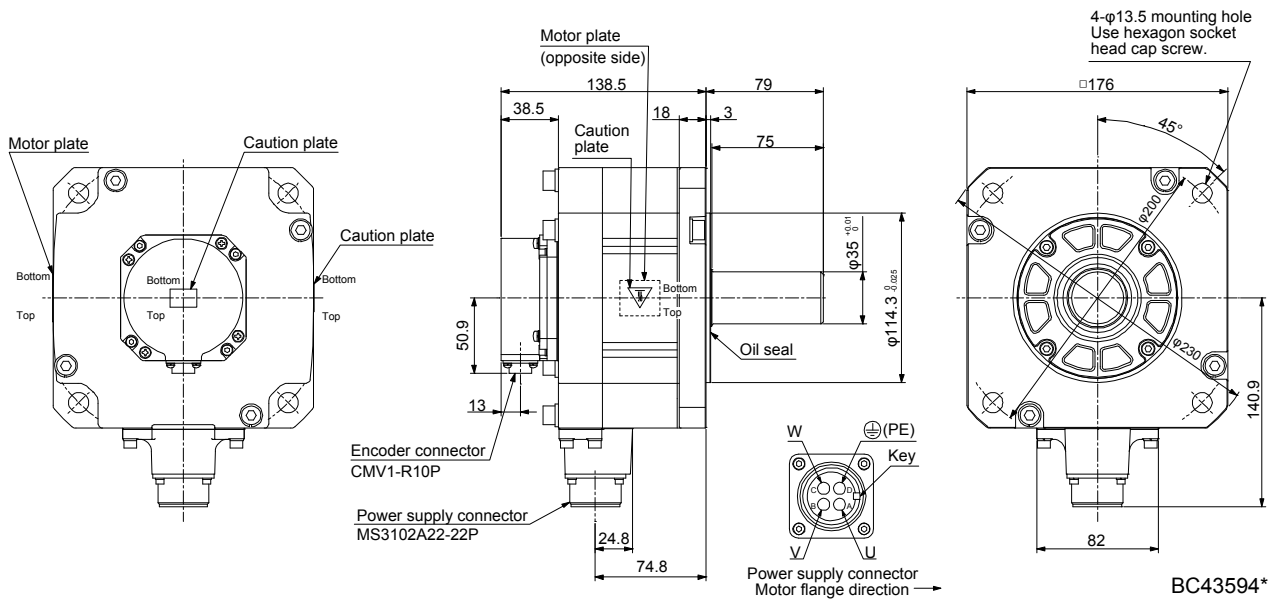

7. HG-SN SERIES

Model	Output [kW]	Moment of inertia J [$\times 10^{-4}$ kg·m ²]	Mass [kg]
HG-SN302J	3.0	78.6	16

[Unit: mm]

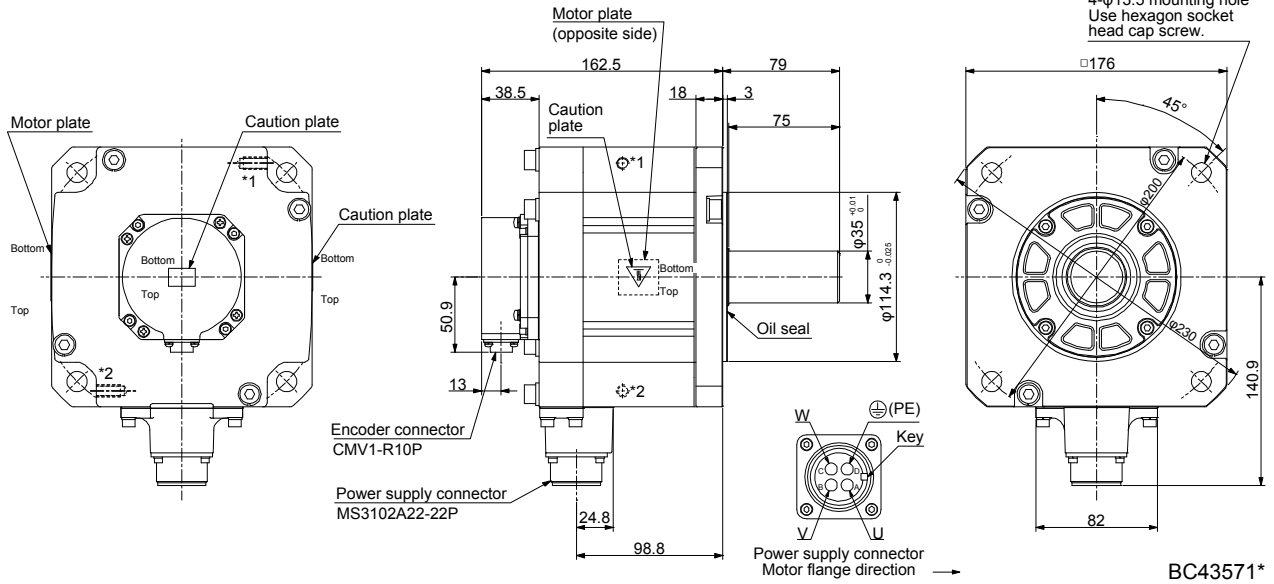

7.7.2 With an electromagnetic brake

Model	Output [kW]	Brake static friction torque [N·m]	Moment of inertia J [$\times 10^{-4}$ kg·m ²]	Mass [kg]
HG-SN52BJ	0.5	8.5	9.48	6.7

[Unit: mm]

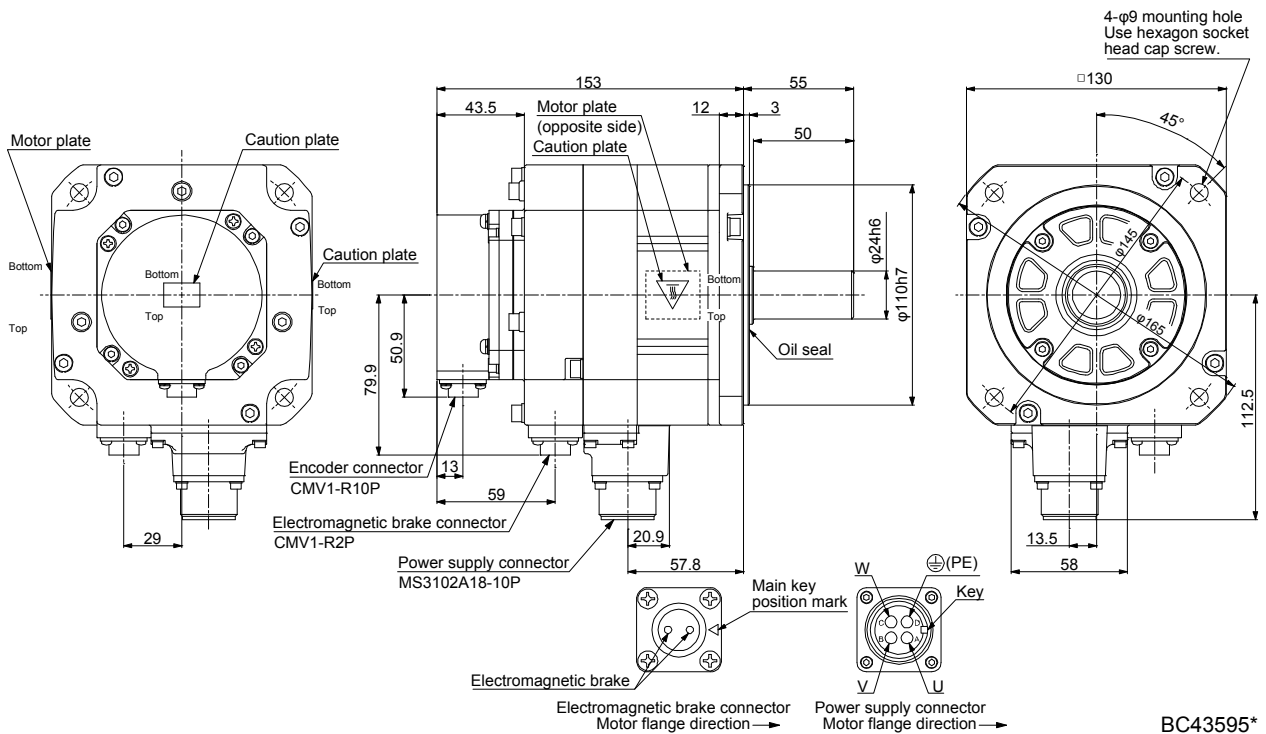

7. HG-SN SERIES

Model	Output [kW]	Brake static friction torque [N·m]	Moment of inertia J [$\times 10^{-4}$ kg·m ²]	Mass [kg]
HG-SN102BJ	1.0	8.5	13.8	8.2

[Unit: mm]

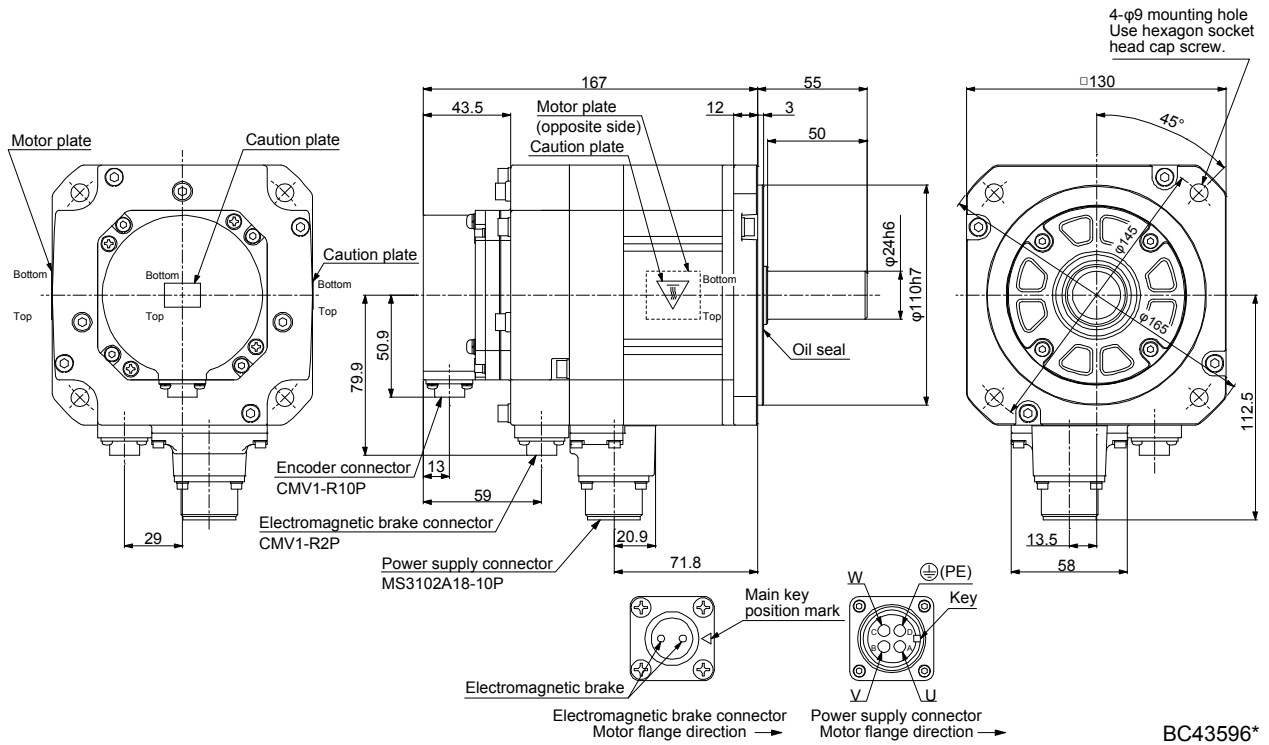

Model	Output [kW]	Brake static friction torque [N·m]	Moment of inertia J [$\times 10^{-4}$ kg·m ²]	Mass [kg]
HG-SN152BJ	1.5	8.5	18.2	9.3

[Unit: mm]

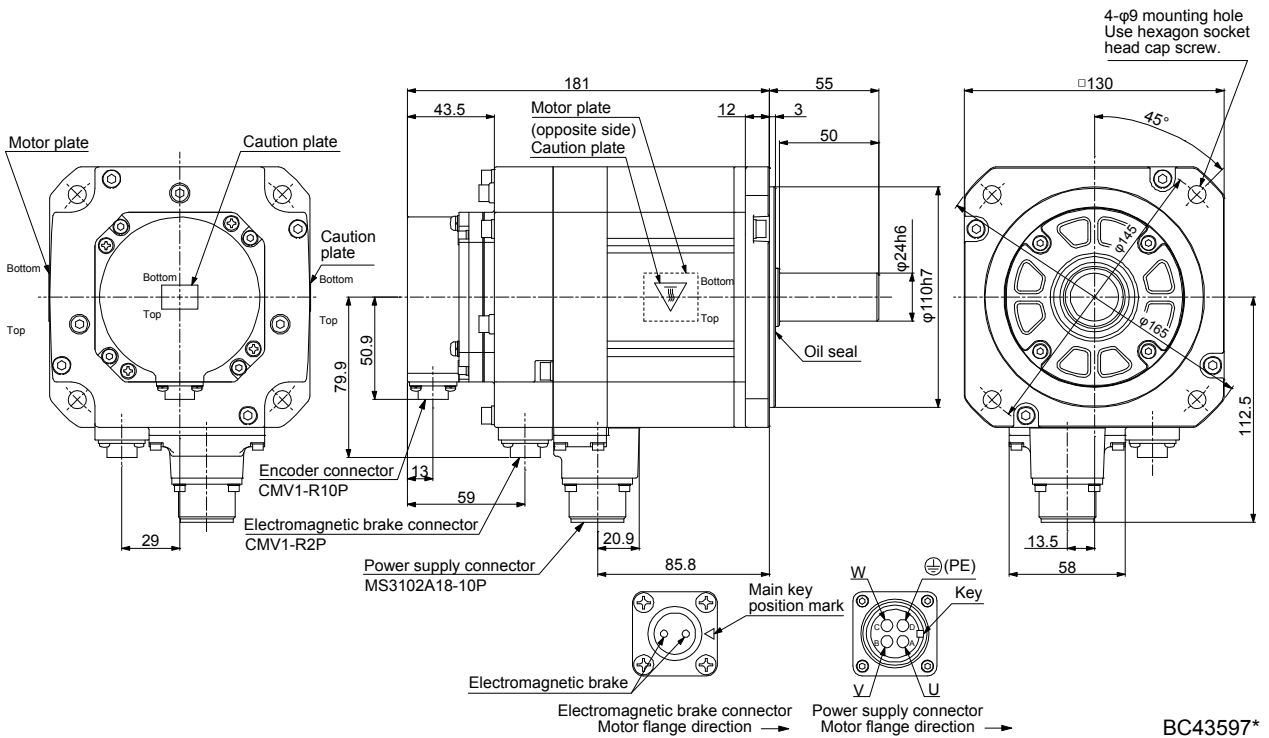

7. HG-SN SERIES

Model	Output [kW]	Brake static friction torque [N·m]	Moment of inertia J [$\times 10^{-4}$ kg·m ²]	Mass [kg]
HG-SN202BJ	2.0	44	56.5	17

[Unit: mm]

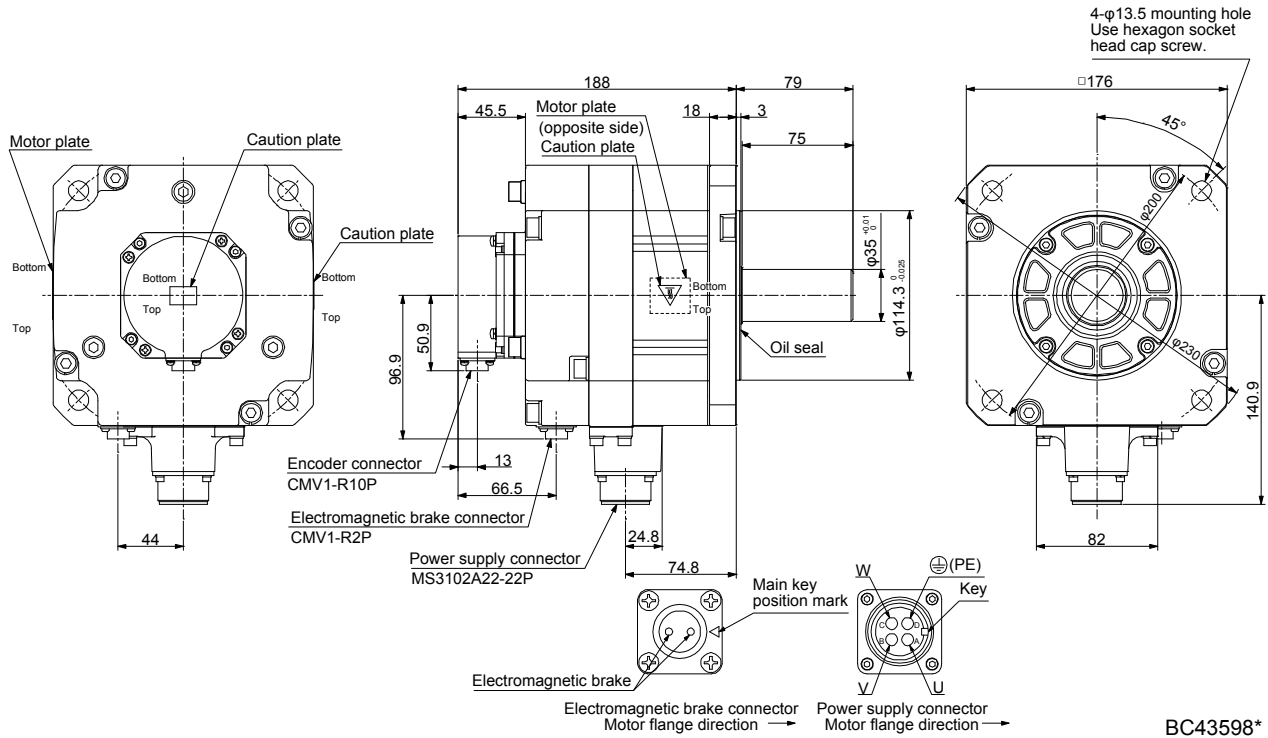

Model	Output [kW]	Brake static friction torque [N·m]	Moment of inertia J [$\times 10^{-4}$ kg·m ²]	Mass [kg]
HG-SN302BJ	3.0	44	88.2	22

[Unit: mm]

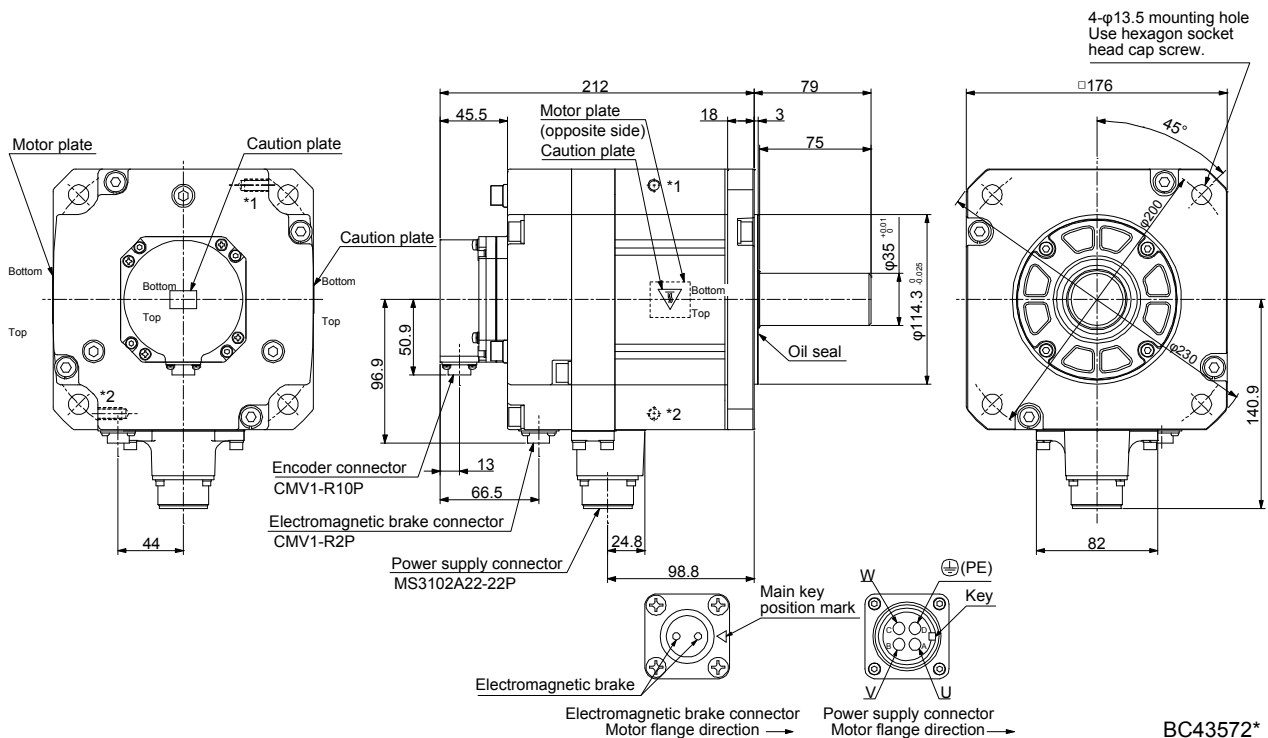

APPENDIX

APPENDIX

App. 1 Servo motor ID codes

Servo motor series ID	Servo motor type ID	Servo motor encoder ID	Servo motor
1F	FF13	004B	HG-KN13
	FF23		HG-KN23
	FF43		HG-KN43
	FF73		HG-KN73
36	FF52		HG-SN52
	F102		HG-SN102
	F152		HG-SN152
	F202		HG-SN202
	F302		HG-SN302

App. 2 Manufacturer list

Names given in the table are as of August 2017.

For information, such as the delivery time, price, and specifications of the recommended products, contact each manufacturer.

Manufacturer	Contact
3M	3M
JST	J.S.T. Mfg. Co., Ltd.
DDK	DDK Ltd.
TE Connectivity	TE Connectivity Ltd. Company
Taiyo Cabletec	Taiyo Cabletec Corporation
Toa Electric Industrial	Toa Electric Industrial Co. Ltd.
JAE	Japan Aviation Electronics Industry, Limited
Hirose Electric	Hirose Electric Co., Ltd.
Molex	Molex

APPENDIX

App. 3 Compliance with the CE marking

App. 3.1 What is CE marking?

The CE marking is mandatory and must be affixed to specific products placed on the European Union. When a product conforms to the requirements, the CE marking must be affixed to the product. The CE marking also applies to machines and equipment incorporating servos.

A manual is available in different languages. For details, contact your local sales office.

(1) EMC directive

The EMC directive applies to the servo motor alone. Therefore servo motor is designed to comply with the EMC directive. The EMC directive also applies to machines and equipment incorporating servo motors. HG-KN and HG-SN series comply with EN61800-3 Category 3. They are not intended to be used on a low-voltage public network which supplies domestic premises; radio frequency interference is expected if it is used on such a network. The installer shall provide a guide for installation and use, including recommended mitigation devices.

(2) Low voltage directive

The low voltage directive also applies to the servo motor alone. The servo motor is designed to comply with the low voltage directive.

(3) Machinery directive

The servo motor as a single unit does not comply with the Machinery directive due to correspondence with article 1 2. (k). However, the Machinery directive applies to machines and equipment incorporating servo motors. Please check your machines and equipment as a whole if they are complied.

App. 3.2 For compliance

Be sure to perform an appearance inspection of every unit before installation. In addition, have a final performance inspection on the entire machine/system, and keep the inspection record.

(1) Wiring

Use wiring which comply with EN for the servo motor power. Products in compliance with EN are available as options.

(2) Performing EMC tests

When EMC tests are run on a machine and device into which the servo motor and servo motor have been installed, it must conform to the electromagnetic compatibility (immunity/emission) standards after it has satisfied the operating environment and electrical equipment specifications.

For EMC directive conforming methods about servo amplifiers and servo motors, refer to "EMC Installation Guidelines" and each servo amplifier instruction manual.

APPENDIX

App. 4 Compliance with UL/CSA standard

POINT
<p>● When you conform HG-KN series servo motor to the UL/CSA standard as a certified product by UL, the insulation class will be 105 (A). The insulation class is approved for 130 (B) as for the UL/CSA standard by TÜV Rheinland.</p>

Use the UL/CSA standard-compliant model of servo motor. For the latest information of compliance, contact your local sales office.

Unless otherwise specified, the handling, performance, specifications, etc. of the UL/CSA standard-compliant models are the same as those of the standard models.

The UL/CSA standard-compliant products are certified by UL and TÜV Rheinland. Their conditions of certification may be different.

(1) Flange size

The servo motor is compliant with the UL/CSA standard when it is mounted on the flanges made of aluminum whose sizes are indicated in the following table.

The rated torque of the servo motor under the UL/CSA standard indicates the continuous permissible torque value that can be generated when it is mounted on the flange specified in this table and used in the environment of 0 °C to 40 °C ambient temperature. Therefore, to conform to the UL/CSA standard, mount the servo motor on a flange with a heat radiating effect equivalent to that of this flange.

Flange size [mm]	Servo motor	
	HG-KN	HG-SN
250 × 250 × 6	13/23 (Note 1)	
250 × 250 × 12	43	52/102/152
300 × 300 × 12	73 (Note 1)	
300 × 300 × 20		202/302
500 × 500 × 20	13/23/43 (Note 2)	
600 × 600 × 30	73 (Note 2)	

Note 1. Certified by TÜV Rheinland
2. Certified by UL

(2) Selection example of wires

To comply with the UL/CSA standard, use UL-approved copper wires rated at 75 °C for wiring. The following table shows wires [AWG] rated at 75 °C.

Servo motor	Wire [AWG]	
	1) U/V/W/⊕	2) B1/B2
HG-KN13	14 (Note)	16 (Note)
HG-KN23		
HG-KN43		
HG-KN73		
HG-SN52	14	16
HG-SN102		
HG-SN152		
HG-SN202		
HG-SN302	12	

Note. For fabricating extension cables

APPENDIX

App. 5 Selection example of servo motor power cable

POINT
● Selection conditions of wire size are as follows. Wire length: 30 m or less
● Some cables do not fit into the option or the recommended cable clamp. Select a cable clamp according to the cable diameter.

Selection example when using the 600 V grade EP rubber insulated chloroprene sheath cab-tire cable (2PNCT) for servo motor power (U/V/W) is indicated below.

Servo motor	Wire size [mm ²]
HG-SN52	1.25
HG-SN102	1.25
HG-SN152	2
HG-SN202	2
HG-SN302	3.5

APPENDIX

App. 6 Connector dimensions

The connector dimensions for wiring the servo motor are shown below.

(1) TE Connectivity 2174053-1

[Unit: mm]

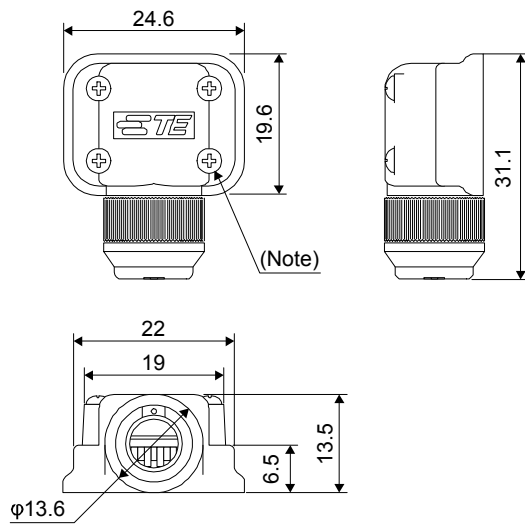

Note: The recommended screw tightening torque is 0.1 N•m.

Crimping tool: 1596970-1 (for ground clip)
1596847-1 (for receptacle contact)

(2) JAE JN4FT02SJ1-R

[Unit: mm]

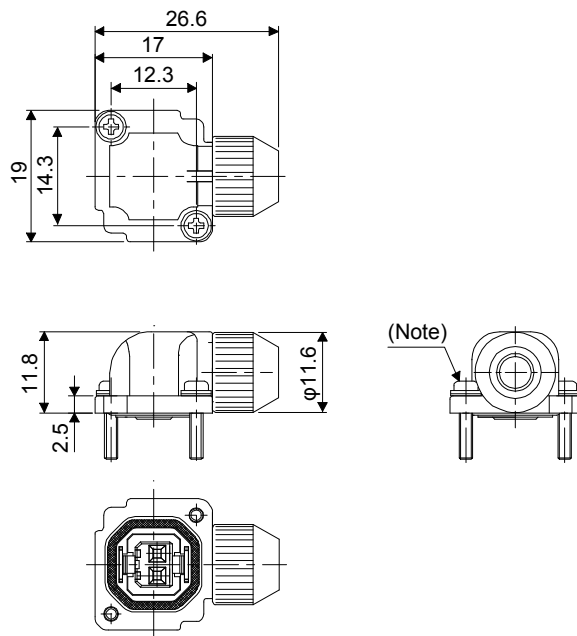

Note: The recommended screw tightening torque is 0.2 N•m.

Crimping tool: CT170-14-TMH5B

APPENDIX

KN4FT04SJ1-R

[Unit: mm]

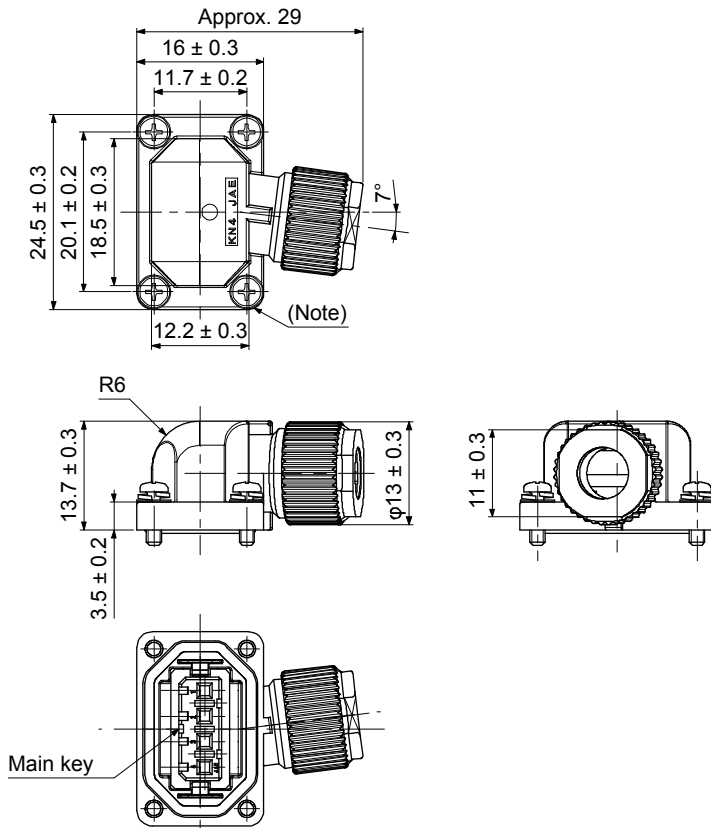

Note. The recommended screw tightening torque is 0.2 N•m.

Crimping tool: CT170-14-TMH5B

(3) DDK

(a) CMV1-SP10S-M_/CMV1-SP2S-_ Refer to section 3.3 for details of crimping tools.

[Unit: mm]

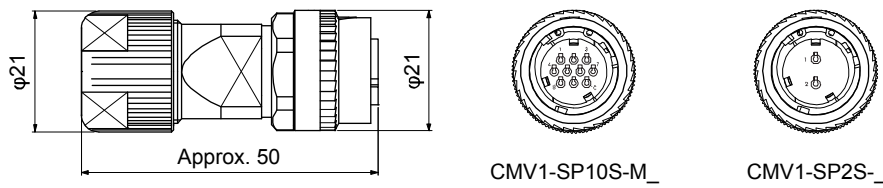

APPENDIX

(b) CMV1-AP10S-M_/CMV1-AP2S-_
 Refer to section 3.3 for details of crimping tools.

[Unit: mm]

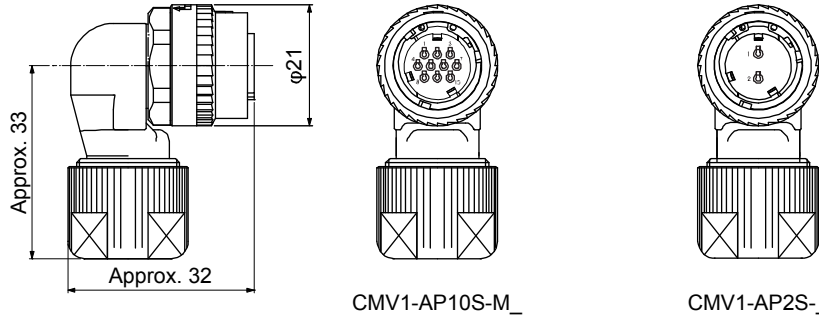

(c) CE05-6A_-SD-D-BSS

[Unit: mm]

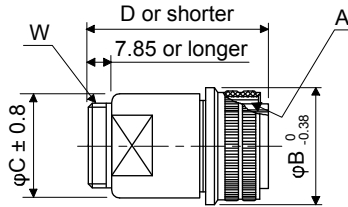

Model	A	B	C	D	W
CE05-6A18-10SD-D-BSS	1 1/8-18UNEF-2B	34.13	32.1	57	1-20UNEF-2A
CE05-6A22-22SD-D-BSS	1 3/8-18UNEF-2B	40.48	38.3	61	1 3/16-18UNEF-2A

(d) CE05-8A_-SD-D-BAS

[Unit: mm]

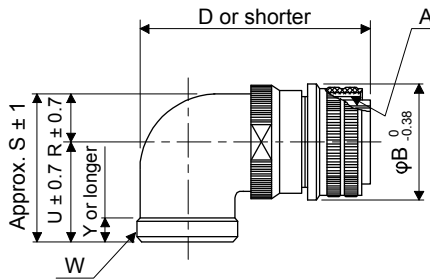

Model	A	B	D	W	R	U	(S)	Y
CE05-8A18-10SD-D-BAS	1 1/8-18UNEF-2B	34.13	69.5	1-20UNEF-2A	13.2	30.2	43.4	7.5
CE05-8A22-22SD-D-BAS	1 3/8-18UNEF-2B	40.48	75.5	1 3/16-18UNEF-2A	16.3	33.3	49.6	7.5

APPENDIX

(e) CE3057-A-D

[Unit: mm]

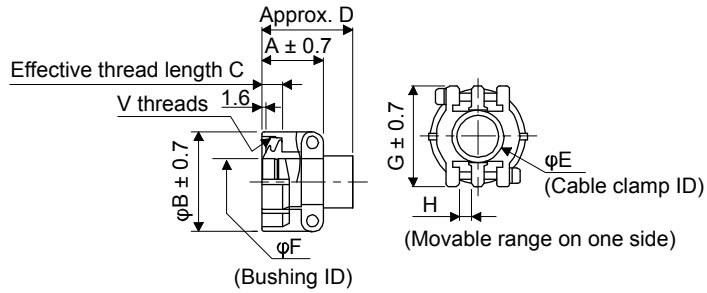

Model	Shell size	A	B	C	D	E	F	G	H	V	Bushing	Cable OD
CE3057-10A-1-D	18	23.8	30.1	10.3	41.3	15.9	14.1	31.7	3.2	1-20UNEF-2B	CE3420-10-1	10.5 to 14.1
CE3057-10A-2-D							11.0				CE3420-10-2	8.5 to 11
CE3057-12A-1-D	22	23.8	35	10.3	41.3	19	16.0	37.3	4.0	1 3/16-18UNEF-2B	CE342012-1	12.5 to 16
CE3057-12A-2-D							13.0				CE342012-2	9.5 to 13

(f) D/MS3106B-S

[Unit: mm]

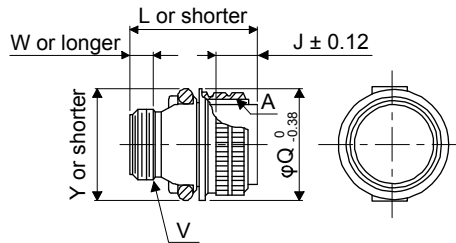

Model	A	J	L	Q	V	W	Y
D/MS3106B18-10S	1 1/8-18UNEF	18.26	52.37	34.13	1-20UNEF	9.53	42
D/MS3106B22-22S	1 3/8-18UNEF	18.26	56.57	40.48	1 3/16-18UNEF	9.53	50

APPENDIX

(g) D/MS3108B_-_S

[Unit: mm]

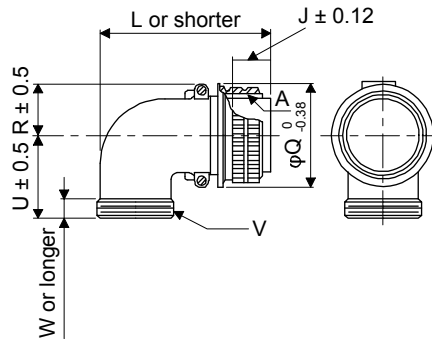

Model	A	J	L	Q	R	U	V	W
D/MS3108B18-10S	1 1/8-18UNEF	18.26	68.27	34.13	20.5	30.2	1-20UNEF	9.53
D/MS3108B22-22S	1 3/8-18UNEF	18.26	76.98	40.48	24.1	33.3	1 3/16-18UNEF-2A	9.53

(h) D/MS3057-_A

[Unit: mm]

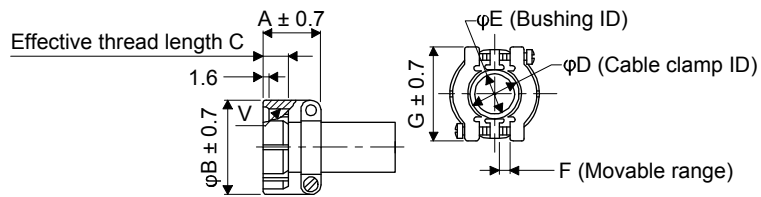

Model	Shell size	A	B	C	D	E	F	G	V	Bushing
D/MS3057-10A	18	23.8	30.1	10.3	15.9	14.3	3.2	31.7	1-20UNEF	AN3420-10
D/MS3057-12A	22	23.8	35.0	10.3	19.0	15.9	4.0	37.3	1 3/16-18UNEF-2A	AN3420-12

(i) CE05-6A32-17SD-D

[Unit: mm]

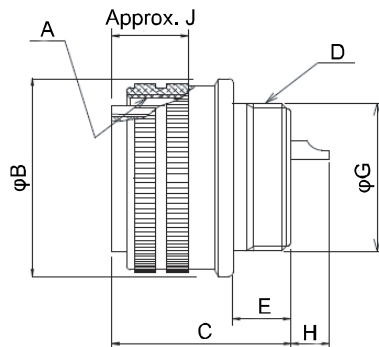

Model	A	B	C	D	E	G	H	J
CE05-6A32-17SD-D	2-18UNS-2B	56.33	37.0	1 7/8-16UN-2A	13.14	45.3	9.2	19.4

APPENDIX

- (j) CMV1S-SP10S-M_/CMV1S-SP2S-_
 Refer to section 3.3 for details of crimping tools.

[Unit: mm]

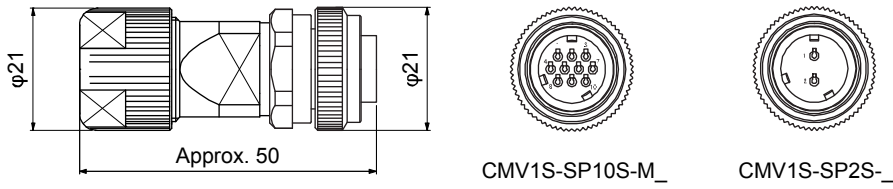

- (k) CMV1S-AP10S-M_/CMV1S-AP2S-_
 Refer to section 3.3 for details of crimping tools.

[Unit: mm]

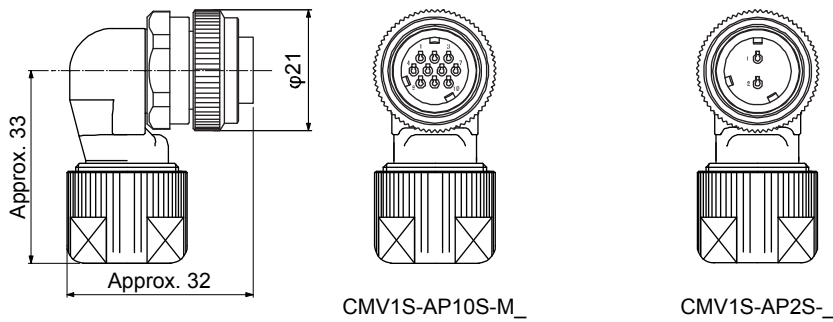

f

REVISIONS

*The manual number is given on the bottom left of the back cover.

Revision Date	*Manual Number	Revision
Oct. 2014	SH(NA)030135ENG-A	First edition
Nov. 2016	SH(NA)030135ENG-B	<p>The HG-KN series servo motors can be operated at a maximum speed of 6000 r/min.</p> <p>4. Additional instructions</p> <p>(1) Transportation and installation The ambient humidity is changed.</p> <p>(5) Corrective actions Partially added.</p> <p>Section 1.1 The rating plate is changed.</p> <p>Section 1.3 The sentences of CAUTION are changed and partially changed.</p> <p>Chapter 2 The sentences are added to CAUTION.</p> <p>Section 2.5 (1) The sentence is added.</p> <p>Section 3.2 Partially changed.</p> <p>Section 4.2.1 Partially changed.</p> <p>Section 5.1.1 Partially changed.</p> <p>Section 5.1.2 Partially changed.</p> <p>Section 5.2 The sentences are added and partially changed.</p> <p>Section 5.3 Partially changed.</p> <p>Section 5.4 Partially changed.</p> <p>Section 5.5 Partially changed.</p> <p>Section 6.3.1 The contents are partially added to the table and diagram is changed.</p> <p>Section 6.3.2 The diagrams are changed.</p> <p>Section 6.7 The diagram is partially changed.</p> <p>Section 7.3.1 The contents are partially added to the table and diagram is changed.</p> <p>App. 2 Partially changed.</p> <p>App. 3 Partially changed.</p> <p>App. 6 (2) The diagrams are partially changed.</p>
Mar. 2017	SH(NA)030135ENG-C	<p>The servo amplifier model is added.</p> <p>Section 1.1 Partially changed.</p> <p>Section 6.3.1 Partially changed.</p> <p>Section 6.2 The part of table is changed.</p> <p>Section 7.3.1 Partially changed.</p> <p>Section 7.2 The part of table is changed.</p> <p>App. 4 The part of table is changed.</p>
Aug. 2017	SH(NA)030135ENG-D	<p>MR-JE-200C and MR-JE-300C are added, and a maximum altitude of 2000 m above sea level is supported.</p> <p>3. To prevent injury, note the following Partially changed.</p> <p>4. Additional instructions Partially changed.</p> <p>Chapter 2 The sentences are added to CAUTION.</p> <p>Section 2.10 Added.</p> <p>Section 2.11 Added.</p> <p>Section 6.3.1 Partially changed.</p> <p>Section 7.2 Model names are added.</p> <p>Section 7.3.1 Partially changed.</p> <p>App. 2 Partially changed.</p>

Revision Date	*Manual Number	Revision
Nov. 2025	SH(NA)030135ENG-E	<p>The back cover is changed.</p> <p>Notes are added to the electromagnetic brake cable wiring diagrams.</p> <p>Notes are added to the lists of the characteristics of the electromagnetic brake provided for the servo motor with an electromagnetic brake.</p> <ul style="list-style-type: none"> • Edited: <p>Section 4.2.1, Section 4.2.2, Section 6.4, Section 7.4</p>

This manual confers no industrial property rights or any rights of any other kind, nor does it confer any patent licenses. Mitsubishi Electric Corporation cannot be held responsible for any problems involving industrial property rights which may occur as a result of using the contents noted in this manual.

Country/Region	Sales office	Tel/Fax
USA	Mitsubishi Electric Automation, Inc. 500 Corporate Woods Parkway, Vernon Hills, IL 60061, U.S.A.	Tel : +1-847-478-2100 Fax : +1-847-478-2253
Mexico	Mitsubishi Electric Automation, Inc. Mexico Branch Mariano Escobedo #69, Col. Zona Industrial, Tlalnepantla Edo. Mexico, C.P.54030	Tel : +52-55-3067-7500 Fax : -
Brazil	Mitsubishi Electric do Brasil Comercio e Servicos Ltda. Avenida Adelino Cardana, 293, 21 andar, Bethaville, CEP 06401-147, Barueri SP, Brazil	Tel : +55-11-4689-3000 Fax : +55-11-4689-3016
Germany	Mitsubishi Electric Europe B.V. German Branch Mitsubishi-Electric-Platz 1, 40882 Ratingen, Germany	Tel : +49-2102-486-0 Fax : +49-2102-486-1120
UK	Mitsubishi Electric Europe B.V. UK Branch Travellers Lane, UK-Hatfield, Hertfordshire, AL10 8XB, U.K.	Tel : +44-1707-28-8780 Fax : +44-1707-27-8695
Italy	Mitsubishi Electric Europe B.V. Italian Branch Centro Direzionale Colleoni - Palazzo Sirio, Viale Colleoni 7, 20864 Agrate Brianza (MB), Italy	Tel : +39-039-60531 Fax : +39-039-6053-312
Spain	Mitsubishi Electric Europe B.V. Spanish Branch Carretera de Rubi, 76-80-Apdo. 420, 08190 Sant Cugat del Valles (Barcelona), Spain	Tel : +34-935-65-3131 Fax : +34-935-89-1579
France	Mitsubishi Electric Europe B.V. French Branch 25, Boulevard des Bouvets, 92741 Nanterre Cedex, France	Tel : +33-1-55-68-55-68 Fax : +33-1-55-68-57-57
Czech Republic	Mitsubishi Electric Europe B.V. Czech Branch Avenir Business Park, Radlicka 751/113e, 158 00 Praha 5, Czech Republic	Tel : +420-251-551-470 Fax : +420-251-551-471
Poland	Mitsubishi Electric Europe B.V. Polish Branch ul. Krakowska 50, 32-083 Balice, Poland	Tel : +48-12-347-65-00 Fax : +48-12-630-47-01
Russia	Mitsubishi Electric (Russia) LLC St. Petersburg Branch Piskarevsky pr. 2, bld 2, lit "Sch", BC "Benua", office 720; 195027 St. Petersburg, Russia	Tel : +7-812-633-3497 Fax : +7-812-633-3499
Sweden	Mitsubishi Electric Europe B.V. (Scandinavia) Fjellievagen 8, SE-22736 Lund, Sweden	Tel : +46-8-625-10-00 Fax : +46-46-39-70-18
Turkey	Mitsubishi Electric Turkey A.S. Umraniye Branch Serifali Mahallesi Nutuk Sokak No:5, TR-34775 Umraniye / Istanbul, Turkey	Tel : +90-216-526-3990 Fax : +90-216-526-3995
UAE	Mitsubishi Electric Europe B.V. Dubai Branch Dubai Silicon Oasis, P.O.BOX 341241, Dubai, U.A.E.	Tel : +971-4-3724716 Fax : +971-4-3724721
South Africa	Adroit Technologies 20 Waterford Office Park, 189 Witkoppen Road, Fourways, South Africa	Tel : +27-11-658-8100 Fax : +27-11-658-8101
China	Mitsubishi Electric Automation (China) Ltd. Mitsubishi Electric Automation Center, No.1386 Hongqiao Road, Shanghai, China	Tel : +86-21-2322-3030 Fax : +86-21-2322-3000
Taiwan	SETSUYO ENTERPRISE CO., LTD. 6F, No.105, Wugong 3rd Road, Wugu District, New Taipei City 24889, Taiwan	Tel : +886-2-2299-2499 Fax : +886-2-2299-2509
Korea	Mitsubishi Electric Automation Korea Co., Ltd. 7F-9F, Gangseo Hangang Xi-tower A, 401, Yangcheon-ro, Gangseo-Gu, Seoul 07528, Korea	Tel : +82-2-3660-9510 Fax : +82-2-3664-8372/8335
Singapore	Mitsubishi Electric Asia Pte. Ltd. 307 Alexandra Road, Mitsubishi Electric Building, Singapore 159943	Tel : +65-6473-2308 Fax : +65-6476-7439
Thailand	Mitsubishi Electric Factory Automation (Thailand) Co., Ltd. 12th Floor, SV.City Building, Office Tower 1, No. 896/19 and 20 Rama 3 Road, Kwaeng Bangpompang, Khet Yannawa, Bangkok 10120, Thailand	Tel : +66-2682-6522 to 6531 Fax : +66-2682-6020
Indonesia	PT. Mitsubishi Electric Indonesia Gedung Jaya 11th Floor, JL. MH. Thamrin No.12, Jakarta Pusat 10340, Indonesia	Tel : +62-21-3192-6461 Fax : +62-21-3192-3942
Vietnam	Mitsubishi Electric Vietnam Company Limited Unit 01-04, 10th Floor, Vincom Center, 72 Le Thanh Ton Street, District 1, Ho Chi Minh City, Vietnam	Tel : +84-8-3910-5945 Fax : +84-8-3910-5947
India	Mitsubishi Electric India Pvt. Ltd. Pune Branch Emerald House, EL-3, J Block, M.I.D.C., Bhosari, Pune - 411026, Maharashtra, India	Tel : +91-20-2710-2000 Fax : +91-20-2710-2100
Australia	Mitsubishi Electric Australia Pty. Ltd. 348 Victoria Road, P.O. Box 11, Rydalmere, N.S.W 2116, Australia	Tel : +61-2-9684-7777 Fax : +61-2-9684-7245
Japan	Mitsubishi Electric Corporation Tokyo Building, 2-7-3, Marunouchi, Chiyoda-ku, Tokyo 100-8310, Japan	Tel : +81-3-3218-2111

MELSERVO is a trademark or registered trademark of Mitsubishi Electric Corporation in Japan and/or other countries.
All other product names and company names are trademarks or registered trademarks of their respective companies.

Warranty

1. Warranty period and coverage

We will repair any failure or defect hereinafter referred to as "failure" in our FA equipment hereinafter referred to as the "Product" arisen during warranty period at no charge due to causes for which we are responsible through the distributor from which you purchased the Product or our service provider. However, we will charge the actual cost of dispatching our engineer for an on-site repair work on request by customer in Japan or overseas countries. We are not responsible for any on-site readjustment and/or trial run that may be required after a defective unit is repaired or replaced.

[Term]

For terms of warranty, please contact your original place of purchase.

[Limitations]

- (1) You are requested to conduct an initial failure diagnosis by yourself, as a general rule.¶
It can also be carried out by us or our service company upon your request and the actual cost will be charged. However, it will not be charged if we are responsible for the cause of the failure.
- (2) This limited warranty applies only when the condition, method, environment, etc. of use are in compliance with the terms and conditions and instructions that are set forth in the instruction manual and user manual for the Product and the caution label affixed to the Product.
- (3) Even during the term of warranty, the repair cost will be charged on you in the following cases;
 1. a failure caused by your improper storing or handling, carelessness or negligence, etc., and a failure caused by your hardware or software problem
 2. a failure caused by any alteration, etc. to the Product made on your side without our approval
 3. a failure which may be regarded as avoidable, if your equipment in which the Product is incorporated is equipped with a safety device required by applicable laws and has any function or structure considered to be indispensable according to a common sense in the industry
 4. a failure which may be regarded as avoidable if consumable parts designated in the instruction manual, etc. are duly maintained and replaced
 5. any replacement of consumable parts (battery, fan, smoothing capacitor, etc.)
 6. a failure caused by external factors such as inevitable accidents, including without limitation fire and abnormal fluctuation of voltage, and acts of God, including without limitation earthquake, lightning and natural disasters
 7. a failure generated by an unforeseeable cause with a scientific technology that was not available at the time of the shipment of the Product from our company
 8. any other failures which we are not responsible for or which you acknowledge we are not responsible for

2. Term of warranty after the stop of production

- (1) We may accept the repair at charge for another seven (7) years after the production of the product is discontinued. The announcement of the stop of production for each model can be seen in our Sales and Service, etc.
- (2) Please note that the Product (including its spare parts) cannot be ordered after its stop of production.

3. Service in overseas countries

Our regional FA Center in overseas countries will accept the repair work of the Product. However, the terms and conditions of the repair work may differ depending on each FA Center. Please ask your local FA center for details.

4. Exclusion of loss in opportunity and secondary loss from warranty liability

Regardless of the gratis warranty term, Mitsubishi shall not be liable for compensation to:

- (1) Damages caused by any cause found not to be the responsibility of Mitsubishi.
- (2) Loss in opportunity, lost profits incurred to the user by Failures of Mitsubishi products.
- (3) Special damages and secondary damages whether foreseeable or not, compensation for accidents, and compensation for damages to products other than Mitsubishi products.
- (4) Replacement by the user, maintenance of on-site equipment, start-up test run and other tasks.

5. Change of Product specifications

Specifications listed in our catalogs, manuals or technical documents may be changed without notice.

6. Application and use of the Product

- (1) For the use of our AC Servo, its applications should be those that may not result in a serious damage even if any failure or malfunction occurs in AC Servo, and a backup or fail-safe function should operate on an external system to AC Servo when any failure or malfunction occurs.
- (2) Our AC Servo is designed and manufactured as a general purpose product for use at general industries.¶
Therefore, applications substantially influential on the public interest for such as atomic power plants and other power plants of electric power companies, and also which require a special quality assurance system, including applications for railway companies and government or public offices are not recommended, and we assume no responsibility for any failure caused by these applications when used.¶
In addition, applications which may be substantially influential to human lives or properties for such as airlines, medical treatments, railway service, incineration and fuel systems, man-operated material handling equipment, entertainment machines, safety machines, etc. are not recommended, and we assume no responsibility for any failure caused by these applications when used. We will review the acceptability of the abovementioned applications, if you agree not to require a specific quality for a specific application. Please contact us for consultation.
- (3) Mitsubishi Electric shall have no responsibility or liability for any problems involving programmable controller trouble and system trouble caused by DoS attacks, unauthorized access, computer viruses, and other cyberattacks.

SH(NA)030135ENG-E(2511)MEE

MODEL:

MODEL CODE:

MITSUBISHI ELECTRIC CORPORATION

HEAD OFFICE: TOKYO BLDG., 2-7-3, MARUNOUCHI, CHIYODA-KU, TOKYO 100-8310, JAPAN
NAGOYA WORKS: 1-14, YADA-MINAMI 5-CHOME, HIGASHI-KU, NAGOYA 461-8670, JAPAN

When exported from Japan, this manual does not require application to the
Ministry of Economy, Trade and Industry for service transaction permission.

Specifications subject to change without notice.

Compliance with the indicated global standards and regulations is current as of the release date of this manual.