

## General-Purpose AC Servo

MITSUBISHI ELECTRIC SERVO SYSTEM  
**MELSERVO** compatible

# Linear Encoder Instruction Manual

---

-MR-J4- \_A\_  
-MR-J4- \_A\_-RJ  
-MR-J4- \_B\_  
-MR-J4- \_B\_-RJ  
-MR-J4- \_GF\_  
-MR-J4- \_GF\_-RJ  
-MR-J4W2- \_B  
-MR-J4W3- \_B  
-MR-J4-DU\_A\_  
-MR-J4-DU\_A\_-RJ  
-MR-J4-DU\_B\_  
-MR-J4-DU\_B\_-RJ

## ● Safety Instructions ●

Please read the instructions carefully before using the equipment.

Do not attempt to install, operate, maintain or inspect the equipment until you have read through this Instruction Manual and appended documents carefully and can use the equipment correctly. Do not use the equipment until you have a full knowledge of the equipment, safety information and instructions.

In this Instruction Manual, the safety instruction levels are classified into "WARNING" and "CAUTION".



Indicates that incorrect handling may cause hazardous conditions, resulting in death or severe injury.



Indicates that incorrect handling may cause hazardous conditions, resulting in medium or slight injury to personnel or may cause physical damage.

Note that the CAUTION level may lead to a serious consequence according to conditions.

Please follow the instructions of both levels because they are important to personnel safety.

What must not be done and what must be done are indicated by the following diagrammatic symbols.



Indicates what must not be done. For example, "No Fire" is indicated by .



Indicates what must be done. For example, grounding is indicated by .

In this Instruction Manual, instructions at a lower level than the above, instructions for other functions, and so on are classified into "POINT".

After reading this Instruction Manual, keep it accessible to the operator.



## CONTENTS

<b>1. LINEAR ENCODER</b>	<b>1- 1 to 1-78</b>
1.1 Compatible linear encoder list .....	1- 2
1.2 Linear encoder manufactured by Mitutoyo (absolute type) .....	1- 6
1.2.1 AT343A .....	1- 6
1.2.2 AT543A-SC/AT545A-SC.....	1-11
1.2.3 ST741A/ST742A/ST743A/ST744A .....	1-16
1.2.4 ST1341A/ST1342A .....	1-22
1.3 Linear encoder manufactured by Heidenhain .....	1-27
1.3.1 LC 495M/LC 195M (absolute type).....	1-27
1.3.2 LIC 4193M/LIC 4195M/LIC 4197M/LIC 4199M/LIC 2197M/LIC 2199M .....	1-32
1.3.3 LIDA 483/LIDA 485/LIDA 487/LIDA 489/LIDA 287/LIDA 289/LIF 481/LIP 581 (incremental type) .....	1-41
1.4 Linear encoder manufactured by Magnescale .....	1-47
1.4.1 SR77/SR87/SR75/SR85 .....	1-47
1.4.2 SL710 + PL101-RM/RHM (incremental type).....	1-49
1.4.3 SR27A/SR67A.....	1-54
1.4.4 SQ10 + PQ10 + MQ10 (incremental type).....	1-56
1.5 Linear encoder manufactured by Renishaw .....	1-61
1.5.1 RESOLUTE RL40M (absolute position type).....	1-61
1.5.2 EVOLUTE EL40M (absolute type) .....	1-66
1.6 Linear encoder PSLH041 manufactured by NIDEC SANKYO (Incremental type).....	1-71
1.7 A/B/Z-phase differential output linear encoder .....	1-76
<b>2. OPTION CABLE/CONNECTOR SETS</b>	<b>2- 1 to 2- 4</b>
2.1 MR-EKCBL_M-H encoder cable.....	2- 1
2.2 MR-ECNM connector set.....	2- 2
2.3 MR-J3CN2 connector set .....	2- 2
2.4 MR-J4THCBL03M branch cable.....	2- 3
2.5 MR-J4FCCBL03M branch cable.....	2- 4
<b>3. DETAILED EXPLANATION OF [AL. 2A LINEAR ENCODER ERROR 1]</b>	<b>3- 1 to 3- 2</b>
<b>APPENDIX</b>	<b>App.- 1 to App.- 1</b>
App. 1 Production of branch cable for linear servo motor .....	App.- 1
App. 2 Production of branch cable for fully closed loop control system.....	App.- 1
App. 3 Manufacturer list.....	App.- 1



# 1. LINEAR ENCODER

## 1. LINEAR ENCODER



### CAUTION

- More careful measures against oil and dust must be taken for the linear encoder than the linear servo motor. For details, contact each linear encoder manufacturer.

#### POINT

- Always use the linear encoder cable introduced in this chapter. Using other products may cause a malfunction.
- For details of the linear encoder specifications, performance and assurance, contact each linear encoder manufacturer.
- A linear encoder communication method cannot be used depending on the software version of the servo amplifier. Refer to section 1.1 for combinations of the communication methods and software versions.
- When the linear encoder is incorrectly installed, an alarm or a position mismatch may occur. In this case, refer to the following general checking points for the linear encoder to confirm the installation.
  - Check that the gap between the head and scale is proper.
  - Check the scale head for rolling and yawing (looseness of scale head section).
  - Check the scale surface for contamination and scratches.
  - Check that the vibration and temperature are within the specified range.
  - Check that the speed is within the permissible range without overshooting.
- Refer to section 1.1 for combinations of the linear encoders and servo amplifiers.
- When using a shell kit (36310-3200-008/36310-F200-008) of 3M or connector set (54599-1019) of Molex, securely connect the external conductor of the shielded cable to the ground plate and fix it to the connector shell.

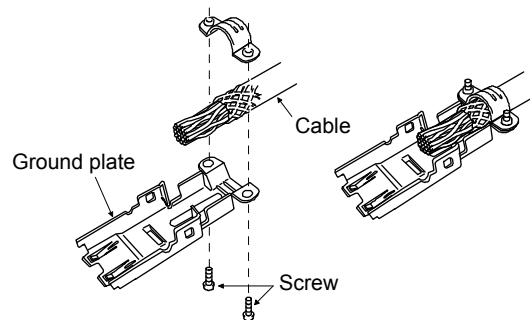

- MR-J4-\_GF\_(-RJ) servo amplifiers with software version A1 or later are compatible with the linear encoder.

# 1. LINEAR ENCODER

## 1.1 Compatible linear encoder list

Scale type		Manufacturer	Model	Resolution	Rated speed (Note 1)	Effective measurement length (maximum) (Note 2)	Communication method	Absolute position detection system
Mitsubishi serial interface compatibility	Absolute position type	Magnescale	SR77	0.05 μm/ 0.01 μm	3.3 m/s	2040 mm	Two-wire type	○
			SR87			3040 mm		
			SR27A	0.01 μm	3.3 m/s	2040 mm	Two-wire type/ four-wire type (Note 4)	
			SR67A			3640 mm		
		Mitutoyo	AT343A	0.05 μm	2.0 m/s	3000 mm	Two-wire type	
			AT543A-SC		2.5 m/s	2200 mm		
			AT545A-SC	20 μm/4096 (approx. 0.005 μm)	2.5 m/s	2200 mm		
			ST741A	0.5 μm	4.0 m/s	6000 mm		
			ST742A					
			ST743A	0.1 μm	4.0 m/s	12000 mm		
			ST744A					
			ST748A					
			ST1341A	0.01 μm	4.0 m/s	4200 mm		
		ST1342A	0.001 μm					
		Renishaw	RESOLUTE RL40M	1 nm/50 nm	4.0 m/s	10000 mm	Two-wire type	
			EVOLUTE EL40M	50 nm/ 100 nm/ 500 nm	4.0 m/s	3020 mm	Two-wire type	
		Heidenhain	LC 495M	0.001 μm/ 0.01 μm	3.0 m/s	2040 mm	Four-wire type (Note 4)	
			LC 195M			4240 mm		
			LIC 4193M	0.005 μm/ 0.01 μm	4.0 m/s	3040 mm	Two-wire type/ four-wire type (Note 4)	
			LIC 4195M			28440 mm		
			LIC 4197M			6040 mm		
			LIC 4199M			1020 mm		
			LIC 2197M	0.05 μm/ 0.1 μm	4.0 m/s	6020 mm	Two-wire type/ four-wire type (Note 4)	
			LIC 2199M			6020 mm		

# 1. LINEAR ENCODER

Scale type		Manufacturer	Model	Resolution	Rated speed (Note 1)	Effective measurement length (maximum) (Note 2)	Communication method	Absolute position detection system
Mitsubishi serial interface compatibility	Incremental type	Magnescale	SR75	0.05 μm/ 0.01 μm	3.3 m/s	2040 mm	Two-wire type	×
			SR85			3040 mm		
			SL710 + PL101-RM/RHM	0.1 μm	4.0 m/s	100000 mm		
			SQ10 + PQ10 + MQ10	0.1 μm/ 0.05 μm	10.0 m/s	3800 mm	Two-wire type/ four-wire type (Note 4)	
		Heidenhain	LIDA 483 + EIB 392M (/16384)	20 μm/16384 (approx. 1.22 nm)	4.0 m/s	3040 mm	Four-wire type (Note 4)	
			LIDA 485 + EIB 392M (/16384)			30040 mm		
			LIDA 487 + EIB 392M (/16384)			6040 mm		
			LIDA 489 + EIB 392M (/16384)			1020 mm		
			LIDA 287 + EIB 392M (/16384)	200 μm/16384 (approx. 12.2 nm)	1.2 m/s	10000 mm		
			LIDA 289 + EIB 392M (/16384)					
			LIF 481 + EIB 392M (/4096)	4 μm/4096 (approx. 0.977 nm)	1020 mm			
LIP 581 + EIB 392M (/4096)	1440 mm							
NIDEC SANKYO	PSLH041 (Note 6)	0.1 μm	5.0 m/s	2400 mm	Two-wire type			
A/B/Z-phase differential output type	Incremental type	Not specified		0.001 μm to 5 μm (Note 3)	Depends on the linear encoder	Depends on the linear encoder	A/B/Z-phase differential output method (Note 5)	

- Note 1. The indicated value is the rated speed of linear encoder when combined with MR-J4 servo amplifier. It may be different from the specifications of each manufacturer.
- Note 2. The indicated value is the specification value of manufacturer. The encoder cable length between the linear encoder and the servo amplifier is maximum 30 m.
- Note 3. Select a linear encoder within the range.
- Note 4. When using a linear encoder of four-wire type with fully closed loop control, use an MR-J4-(DU)\_A\_-RJ, MR-J4-(DU)\_B\_-RJ, or MR-J4-\_GF\_-RJ. When using a linear encoder of four-wire type with scale measurement function, use an MR-J4-(DU)\_B\_-RJ or MR-J4-\_GF\_-RJ.
- Note 5. When using a linear encoder of A/B/Z-phase differential output method, use an MR-J4-(DU)\_A\_-RJ, MR-J4-(DU)\_B\_-RJ, or MR-J4-\_GF\_-RJ.
- Note 6. MR-J4-\_A\_-(-RJ), MR-J4-\_B\_-(-RJ), and MR-J4-W\_B are available with software version B3 or later.

# 1. LINEAR ENCODER

The following table shows connectors of servo amplifiers to connect a linear encoder.

(1) MR-J4-\_A(1)(-RJ), MR-J4-\_B(1)(-RJ), MR-J4-\_GF(-RJ), and MR-J4W\_-\_B

Operation mode	External encoder communication method	Connector							
		MR-J4-_A MR-J4-_A1	MR-J4-_A-RJ MR-J4-_A1-RJ	MR-J4-_B MR-J4-_B1	MR-J4-_B-RJ MR-J4-_B1-RJ	MR-J4-_GF	MR-J4-_GF-RJ	MR-J4W2-_B	MR-J4W3-_B
Linear servo motor system	Two-wire type	CN2 (Note 1, 6)	CN2 (Note 1)	CN2 (Note 1)	CN2 (Note 1)	CN2 (Note 1)	CN2 (Note 1)	CN2A (Note 1) CN2B (Note 1)	CN2A (Note 1) CN2B (Note 1) CN2C (Note 1)
	Four-wire type								
	A/B/Z-phase differential output method		CN2L (Note 8)		CN2L (Note 8)		CN2L (Note 8)		
Fully closed loop system	Two-wire type	CN2 (Note 2, 3, 6)	CN2L	CN2 (Note 2, 3, 5)	CN2L	CN2 (Note 2, 3)	CN2L	CN2A (Note 2, 4, 5) CN2B (Note 2, 4, 5)	
	Four-wire type								
	A/B/Z-phase differential output method								
Scale measurement function	Two-wire type			CN2 (Note 2, 3, 7)	CN2L (Note 7)	CN2 (Note 2, 3)	CN2L	CN2A (Note 2, 4, 7) CN2B (Note 2, 4, 7)	
	Four-wire type								
	A/B/Z-phase differential output method								

Note 1. The MR-J4THCBL03M branch cable is necessary.

2. The MR-J4FCCBL03M branch cable is necessary.

3. When the communication method of the servo motor encoder is four-wire type, MR-J4-\_A(1), MR-J4-\_B(1), and MR-J4-\_GF cannot be used. Use an MR-J4-\_A(1)-RJ, MR-J4-\_B(1)-RJ, or MR-J4-\_GF-RJ.

4. When the communication method of the servo motor encoder is four-wire type, MR-J4W2-\_B cannot be used. Use an MR-J4-\_B-RJ.

5. Supported by servo amplifiers with software version A3 or later.

6. Supported by servo amplifiers with software version A5 or later.

7. Supported by servo amplifiers with software version A8 or later.

8. Connect a thermistor to CN2.

# 1. LINEAR ENCODER

## (2) MR-J4-\_A4(-RJ), MR-J4-\_B4(-RJ), and MR-J4-\_GF4(-RJ)

Operation mode	External encoder communication method	Connector					
		MR-J4-_A4	MR-J4-_A4-RJ	MR-J4-_B4	MR-J4-_B4-RJ	MR-J4-_GF4	MR-J4-_GF4-RJ
Linear servo motor system	Two-wire type	CN2	CN2	CN2	CN2	CN2	CN2
	Four-wire type	(Note 1)	(Note 1)	(Note 1)	(Note 1)	(Note 1)	(Note 1)
	A/B/Z-phase differential output method		CN2L (Note 5)		CN2L (Note 5)		CN2L (Note 5)
Fully closed loop system	Two-wire type	CN2 (Note 2, 3)		CN2 (Note 2, 3)		CN2 (Note 2, 3)	
	Four-wire type		CN2L		CN2L		CN2L
	A/B/Z-phase differential output method						
Scale measurement function	Two-wire type			CN2 (Note 2, 3, 4)		CN2 (Note 2, 3)	
	Four-wire type				CN2L (Note 4)		CN2L
	A/B/Z-phase differential output method						

- Note 1. The MR-J4THCBL03M branch cable is necessary.  
 Note 2. The MR-J4FCCBL03M branch cable is necessary.  
 Note 3. When the communication method of the servo motor encoder is four-wire type, MR-J4-\_A4, MR-J4-\_B4, and MR-J4-\_GF4 cannot be used. Use an MR-J4-\_A4-RJ, MR-J4-\_B(1)-RJ, or MR-J4-\_GF-RJ.  
 Note 4. Supported by servo amplifiers with software version A8 or later.  
 Note 5. Connect a thermistor to CN2.

## (3) For an MR-J4-DU\_A\_(-RJ) and MR-J4-DU\_B\_(-RJ) drive units

Operation mode	External encoder communication method	External connection connector			
		MR-J4-DU_A_	MR-J4-DU_A_-RJ	MR-J4-DU_B_	MR-J4-DU_B_-RJ
Fully closed loop system	Two-wire type	CN2 (Note 1, 2)		CN2 (Note 1, 2)	
	Four-wire type		CN2L		CN2L
	A/B/Z-phase differential output method				
Scale measurement function	Two-wire type			CN2 (Note 1, 2)	
	Four-wire type				CN2L
	A/B/Z-phase differential output method				

- Note 1. The MR-J4FCCBL03M branch cable is necessary.  
 Note 2. When the communication method of the servo motor encoder is four-wire type, MR-J4-DU\_A\_ and MR-J4-DU\_B\_ cannot be used. Use an MR-J4-DU\_A\_-RJ or MR-J4-DU\_B\_-RJ.

# 1. LINEAR ENCODER

## 1.2 Linear encoder manufactured by Mitutoyo (absolute type)

**POINT**

● When the absolute position detection system is configured, the absolute position battery is not required.

### 1.2.1 AT343A

#### (1) Cable composition

Prepare a cable based on the following configuration diagram.

#### (a) For the linear servo motor

- 1) MR-J4-\_A\_/MR-J4-\_B\_/MR-J4-\_GF\_/MR-J4W\_-\_B

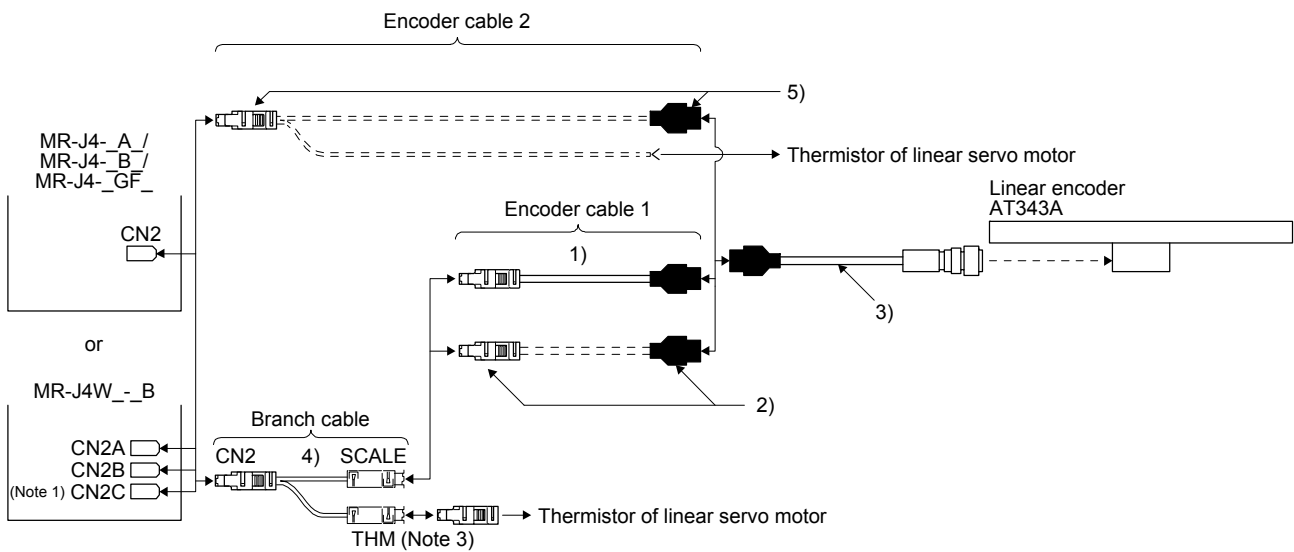

	Branch cable	Encoder cable	Output cable
When using an optional encoder cable	4) MR-J4THCBL03M (Refer to section 2.4.)	1) MR-EKCBL_M-H 2 m/5 m (Refer to section 2.1.)	3) Options manufactured by Mitutoyo (Note 2) Part No.09BAA598A: 0.2 m Part No.09BAA598B: 2 m Part No.09BAA598C: 3 m
When fabricating the encoder cable		2) Connector set MR-ECNM (Refer to (2) (a) of this section.)	
When not using a branch cable		5) Connector set MR-ECNM (Refer to (2) (b) of this section.)	

- Note
1. The connection to CN2C is for the MR-J4 3-axis servo amplifier. MR-J4 2-axis servo amplifier does not have CN2C.
  2. It should be prepared by the customer.
  3. For connectors for thermistor signals, change how to connect depending on the customer's system.

# 1. LINEAR ENCODER

## 2) MR-J4-\_A\_-RJ/MR-J4-\_B\_-RJ/MR-J4-\_GF\_-RJ

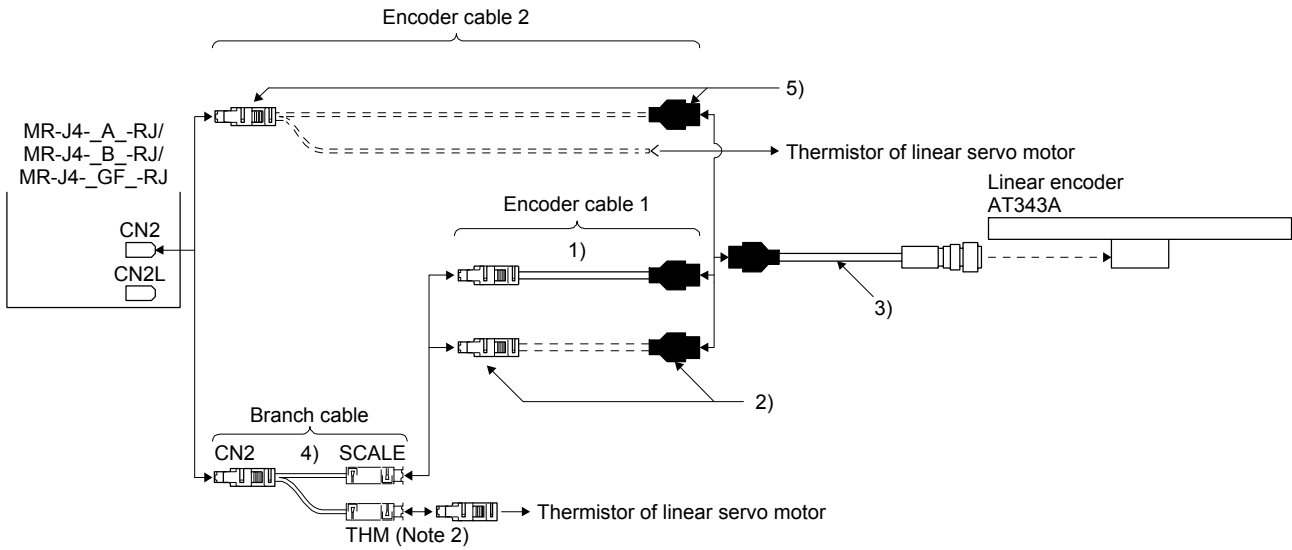

	Branch cable	Encoder cable	Output cable
When using an optional encoder cable	4) MR-J4THCBL03M (Refer to section 2.4.)	1) MR-EKCBL_M-H 2 m/5 m (Refer to section 2.1.)	3) Options manufactured by Mitutoyo (Note 1) Part No.09BAA598A: 0.2 m Part No.09BAA598B: 2 m Part No.09BAA598C: 3 m
When fabricating the encoder cable		2) Connector set MR-ECNM (Refer to (2) (a) of this section.)	
When not using a branch cable		5) Connector set MR-ECNM (Refer to (2) (b) of this section.)	

Note 1. It should be prepared by the customer.

Note 2. For connectors for thermistor signals, change how to connect depending on the customer's system.

# 1. LINEAR ENCODER

(b) For the fully closed loop system and scale measurement function

1) MR-J4-(DU)\_A\_/MR-J4-(DU)\_B\_/MR-J4-\_GF\_/MR-J4W2-\_B

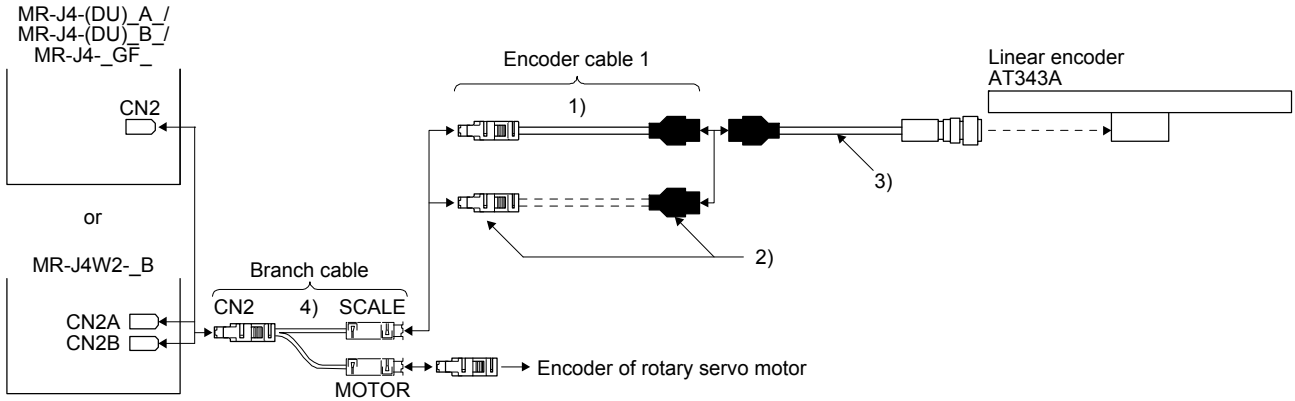

	Branch cable	Encoder cable	Output cable
When using an optional encoder cable	4) MR-J4FCCBL03M (Refer to section 2.5.)	1) MR-EKCBL_M-H 2 m/5 m (Refer to section 2.1.)	3) Options manufactured by Mitutoyo (Note) Part No.09BAA598A: 0.2 m Part No.09BAA598B: 2 m Part No.09BAA598C: 3 m
When fabricating the encoder cable		2) Connector set MR-ECNM (Refer to (2) (a) of this section.)	

Note. It should be prepared by the customer.

2) MR-J4-(DU)\_A\_-RJ/MR-J4-(DU)\_B\_-RJ/MR-J4-\_GF\_-RJ

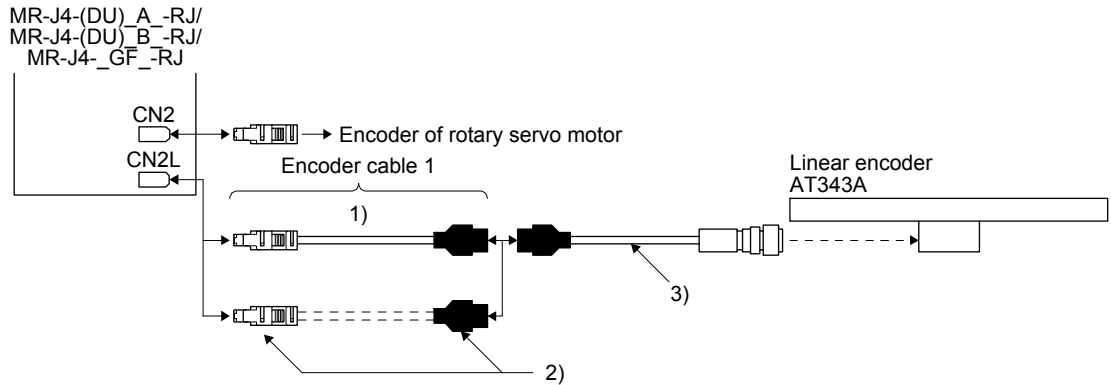

	Encoder cable	Output cable
When using an optional encoder cable	1) MR-EKCBL_M-H 2 m/5 m (Refer to section 2.1.)	3) Options manufactured by Mitutoyo (Note) Part No.09BAA598A: 0.2 m Part No.09BAA598B: 2 m Part No.09BAA598C: 3 m
When fabricating the encoder cable	2) Connector set MR-ECNM (Refer to (2) (a) of this section.)	

Note. It should be prepared by the customer.

# 1. LINEAR ENCODER

## (2) Production of encoder cable

Produce the encoder cable using MR-ECNM as shown below. The encoder cable can be produced as the length of maximum 30 m.

### (a) Encoder cable 1

Receptacle: 36210-0100PL  
Shell kit: 36310-3200-008  
(3M) (Note 2)

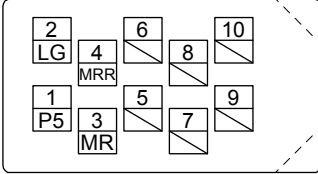

View seen from wiring side. (Note 3)

or

Connector set: 54599-1019  
(Molex) (Note 2)

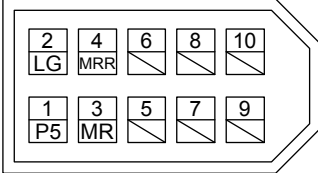

View seen from wiring side. (Note 3)

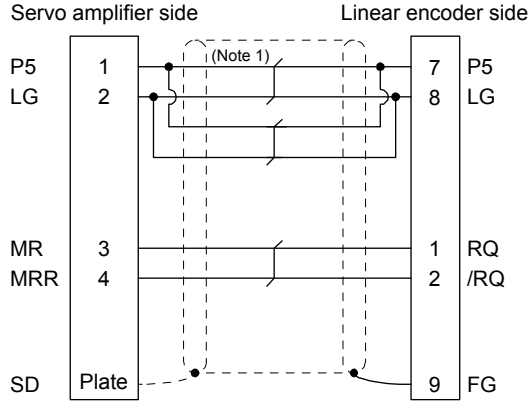

Housing: 1-172161-9  
Connector pin: 170359-1  
(TE Connectivity or equivalent)  
Cable clamp: MTI-0002  
(Toa Electric Industrial)

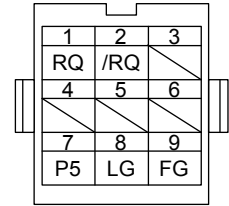

View seen from wiring side.

Note 1. We recommend the following specifications encoder cables.

Wiring length	Number of LG and P5 connections (when the output cable is 3 m or less)	Cable size
to 5 m	1-pair	AWG 22
to 10 m	2-pair	
to 20 m	3-pair	
to 30 m	5-pair	

2. For the CN2L connector, signals of pin 3 and pin 4 will be as follows.

Pin 3: MR2 Pin 4: MRR2

3. Do not connect anything to the pins shown as . Especially, pin 10 is for manufacturer adjustment. If it is connected with any other pin, the servo amplifier cannot operate normally. Referring to POINT of chapter 1, securely connect the external conductor of the shielded cable to the ground plate and fix it to the connector shell.

# 1. LINEAR ENCODER

## (b) Encoder cable 2

Receptacle: 36210-0100PL  
Shell kit: 36310-3200-008  
(3M)

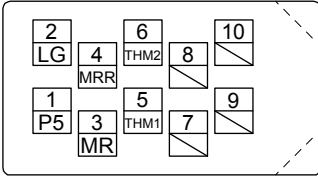

View seen from wiring side. (Note 3)

or

Connector set: 54599-1019  
(Molex)

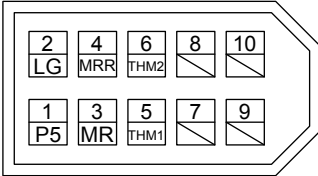

View seen from wiring side. (Note 3)

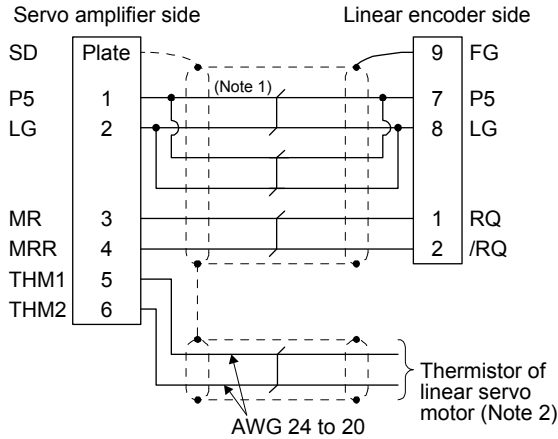

Housing: 1-172161-9  
Connector pin: 170359-1  
(TE Connectivity or equivalent)  
Cable clamp: MTI-0002  
(Toa Electric Industrial)

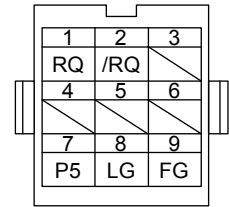

View seen from wiring side.

Note 1. We recommend the following specifications encoder cables.

Wiring length	Number of LG and P5 connections (when the output cable is 3 m or less)	Cable size
to 5 m	1-pair	AWG 22
to 10 m	2-pair	
to 20 m	3-pair	
to 30 m	5-pair	

- For wiring to the thermistor of the linear servo motor, refer to "Linear Servo Motor Instruction Manual".
- Do not connect anything to the pins shown as . Especially, pin 10 is for manufacturer adjustment. If it is connected with any other pin, the servo amplifier cannot operate normally. Referring to POINT of chapter 1, securely connect the external conductor of the shielded cable to the ground plate and fix it to the connector shell.

# 1. LINEAR ENCODER

## 1.2.2 AT543A-SC/AT545A-SC

### (1) Cable composition

Prepare a cable based on the following configuration diagram.

#### (a) For the linear servo motor

- 1) MR-J4-\_A\_/MR-J4-\_B\_/MR-J4-\_GF\_/MR-J4W\_-\_B

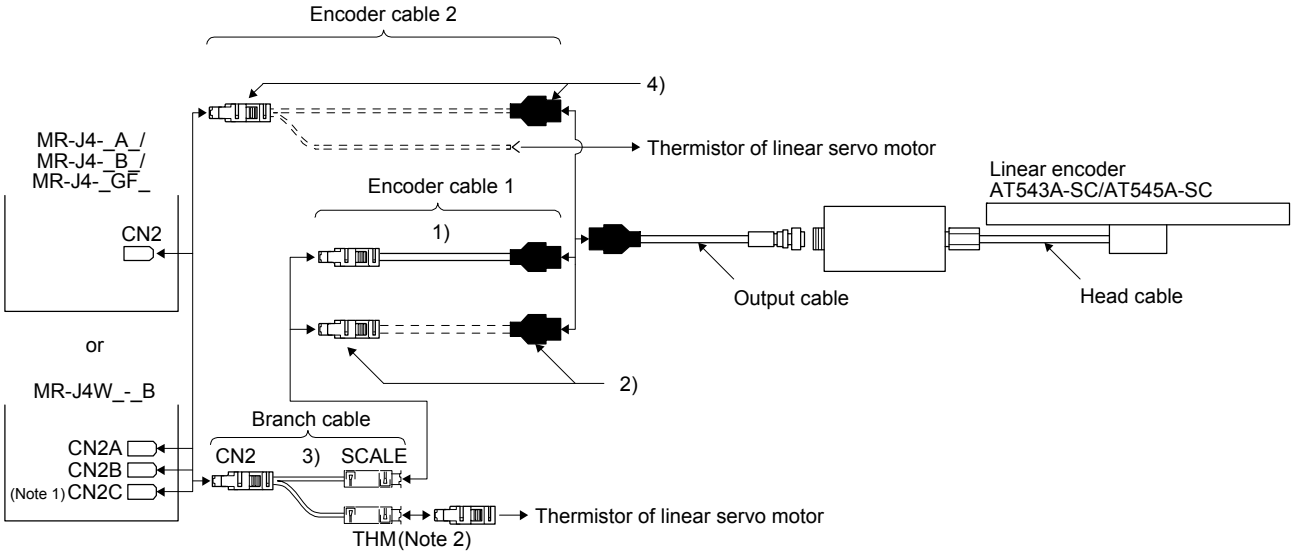

	Branch cable	Encoder cable	Output cable	Head cable
When using an optional encoder cable	3) MR-J4THCBL03M (Refer to section 2.4.)	1) MR-EKCBL_M-H 2 m/5 m (Refer to section 2.1.)	Accessories for linear encoder Cable length: 3 m	Accessories for linear encoder Cable length: 2 m
When fabricating the encoder cable		2) Connector set MR-ECNM (Refer to (2) (a) of this section.)		
When not using a branch cable		4) Connector set MR-ECNM (Refer to (2) (b) of this section.)		

- Note 1. The connection to CN2C is for the MR-J4 3-axis servo amplifier. MR-J4 2-axis servo amplifier does not have CN2C.  
 Note 2. For connectors for thermistor signals, change how to connect depending on the customer's system.

# 1. LINEAR ENCODER

## 2) MR-J4-\_A\_-RJ/MR-J4-\_B\_-RJ/MR-J4-\_GF\_-RJ

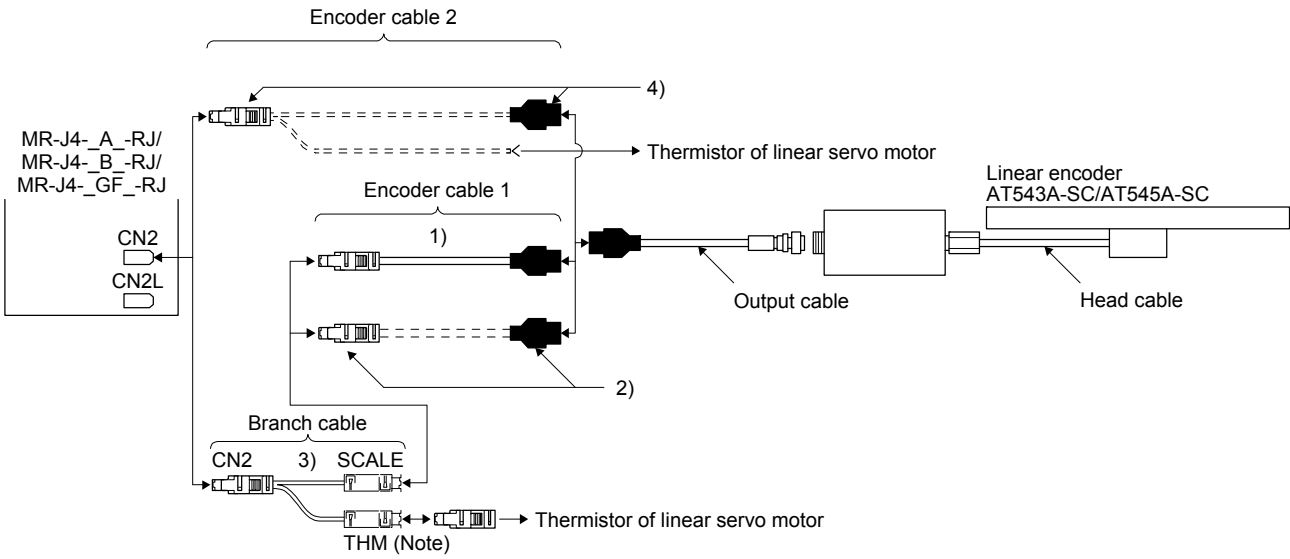

	Branch cable	Encoder cable	Output cable	Head cable
When using an optional encoder cable	3) MR-J4THCBL03M (Refer to section 2.4.)	1) MR-EKCBL_M-H 2 m/5 m (Refer to section 2.1.)	Accessories for linear encoder Cable length: 3 m	Accessories for linear encoder Cable length: 2 m
When fabricating the encoder cable		2) Connector set MR-ECNM (Refer to (2) (a) of this section.)		
When not using a branch cable		4) Connector set MR-ECNM (Refer to (2) (b) of this section.)		

Note. For connectors for thermistor signals, change how to connect depending on the customer's system.

# 1. LINEAR ENCODER

(b) For the fully closed loop system and scale measurement function

1) MR-J4-(DU)\_A\_/MR-J4-(DU)\_B\_/MR-J4-\_GF\_/MR-J4W2-\_B

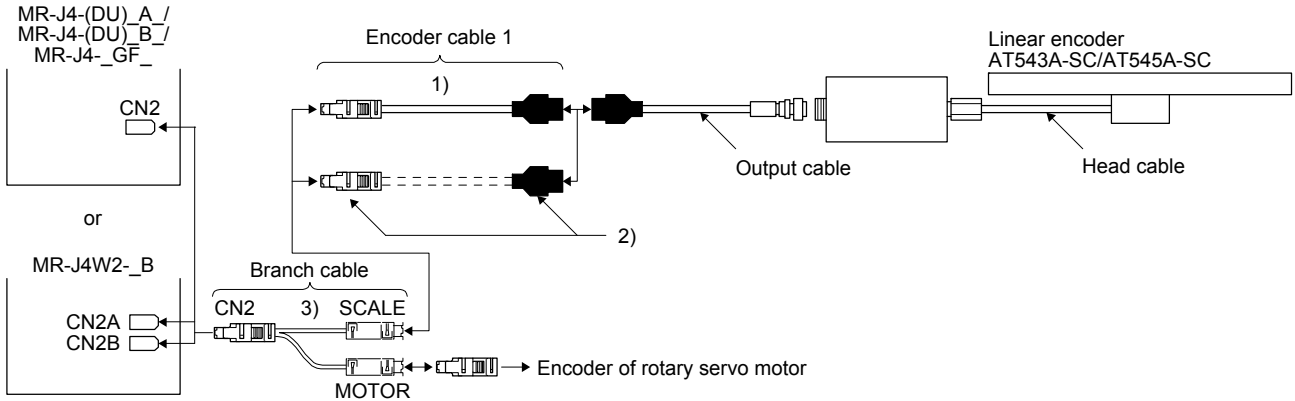

	Branch cable	Encoder cable	Output cable	Head cable
When using an optional encoder cable	3) MR-J4FCCBL03M (Refer to section 2.5.)	1) MR-EKCBL_M-H 2 m/5 m (Refer to section 2.1.)	Accessories for linear encoder Cable length: 3 m	Accessories for linear encoder Cable length: 2 m
When fabricating the encoder cable		2) Connector set MR-ECNM (Refer to (2) (a) of this section.)		

2) MR-J4-(DU)\_A\_-RJ/MR-J4-(DU)\_B\_-RJ/MR-J4-\_GF\_-RJ

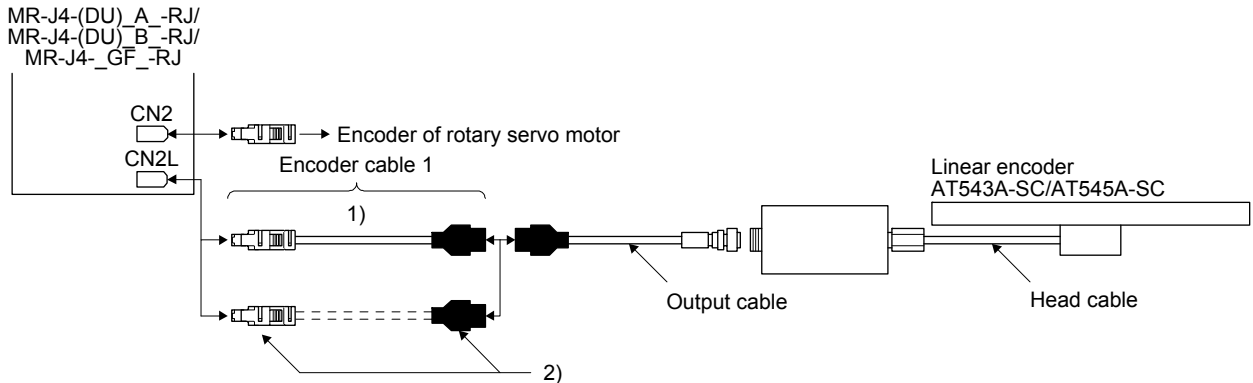

	Encoder cable	Output cable	Head cable
When using an optional encoder cable	1) MR-EKCBL_M-H 2 m/5 m (Refer to section 2.1.)	Accessories for linear encoder Cable length: 3 m	Accessories for linear encoder Cable length: 2 m
When fabricating the encoder cable	2) Connector set MR-ECNM (Refer to (2) (a) of this section.)		

# 1. LINEAR ENCODER

## (2) Production of encoder cable

Produce the encoder cable using MR-ECNM as shown below. The encoder cable can be produced as the length of maximum 30 m.

### (a) Encoder cable 1

Receptacle: 36210-0100PL  
Shell kit: 36310-3200-008  
(3M) (Note 2)

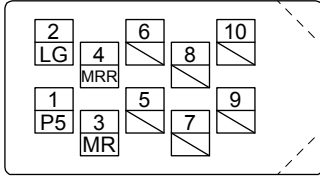

View seen from wiring side. (Note 3) (Note 2)

or

Connector set: 54599-1019  
(Molex) (Note 2)

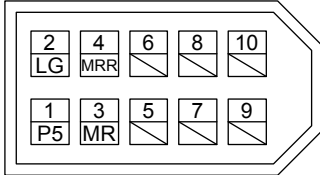

View seen from wiring side. (Note 3)

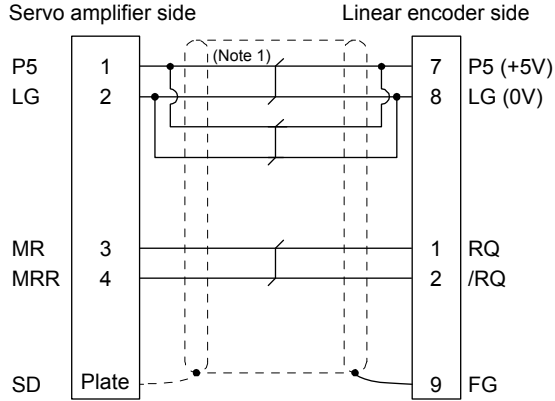

Housing: 1-172161-9  
Connector pin: 170359-1  
(TE Connectivity or equivalent)  
Cable clamp: MTI-0002  
(Toa Electric Industrial)

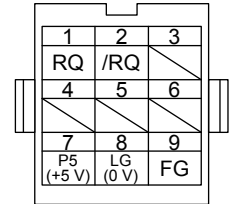

View seen from wiring side.

Note 1. We recommend the following specifications encoder cables.

Wiring length	Number of LG and P5 connections (when the output cable is 3 m or less)	Cable size
to 5 m	1-pair	AWG 22
to 10 m	2-pair	
to 20 m	4-pair	
to 30 m	5-pair	

2. For the CN2L connector, signals of pin 3 and pin 4 will be as follows.

Pin 3: MR2 Pin 4: MRR2

3. Do not connect anything to the pins shown as . Especially, pin 10 is for manufacturer adjustment. If it is connected with any other pin, the servo amplifier cannot operate normally. Referring to POINT of chapter 1, securely connect the external conductor of the shielded cable to the ground plate and fix it to the connector shell.

# 1. LINEAR ENCODER

## (b) Encoder cable 2

Receptacle: 36210-0100PL  
Shell kit: 36310-3200-008  
(3M)

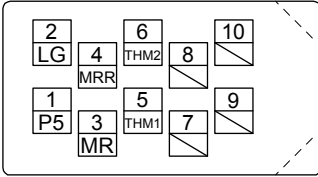

View seen from wiring side. (Note 3)

or

Connector set: 54599-1019  
(Molex)

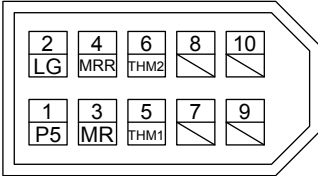

View seen from wiring side. (Note 3)

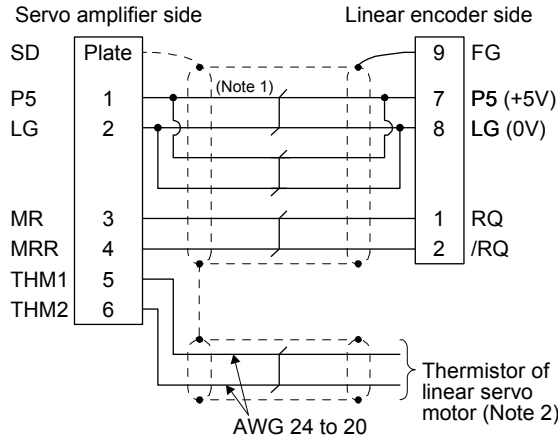

Housing: 1-172161-9  
Connector pin: 170359-1  
(TE Connectivity or equivalent)  
Cable clamp: MTI-0002  
(Toa Electric Industrial)

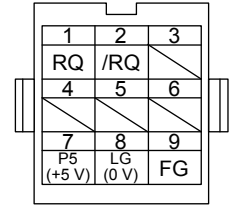

View seen from wiring side.

Note 1. We recommend the following specifications encoder cables.

Wiring length	Number of LG and P5 connections (when the output cable is 3 m or less)	Cable size
to 5 m	1-pair	AWG 22
to 10 m	2-pair	
to 20 m	4-pair	
to 30 m	5-pair	

- For wiring to the thermistor of the linear servo motor, refer to "Linear Servo Motor Instruction Manual".
- Do not connect anything to the pins shown as . Especially, pin 10 is for manufacturer adjustment. If it is connected with any other pin, the servo amplifier cannot operate normally. Referring to POINT of chapter 1, securely connect the external conductor of the shielded cable to the ground plate and fix it to the connector shell.

# 1. LINEAR ENCODER

## 1.2.3 ST741A/ST742A/ST743A/ST744A

### (1) Cable composition

Prepare a cable based on the following configuration diagram.

#### (a) For the linear servo motor

- 1) MR-J4- \_A\_ /MR-J4- \_B\_ /MR-J4- \_GF\_ /MR-J4W- \_B

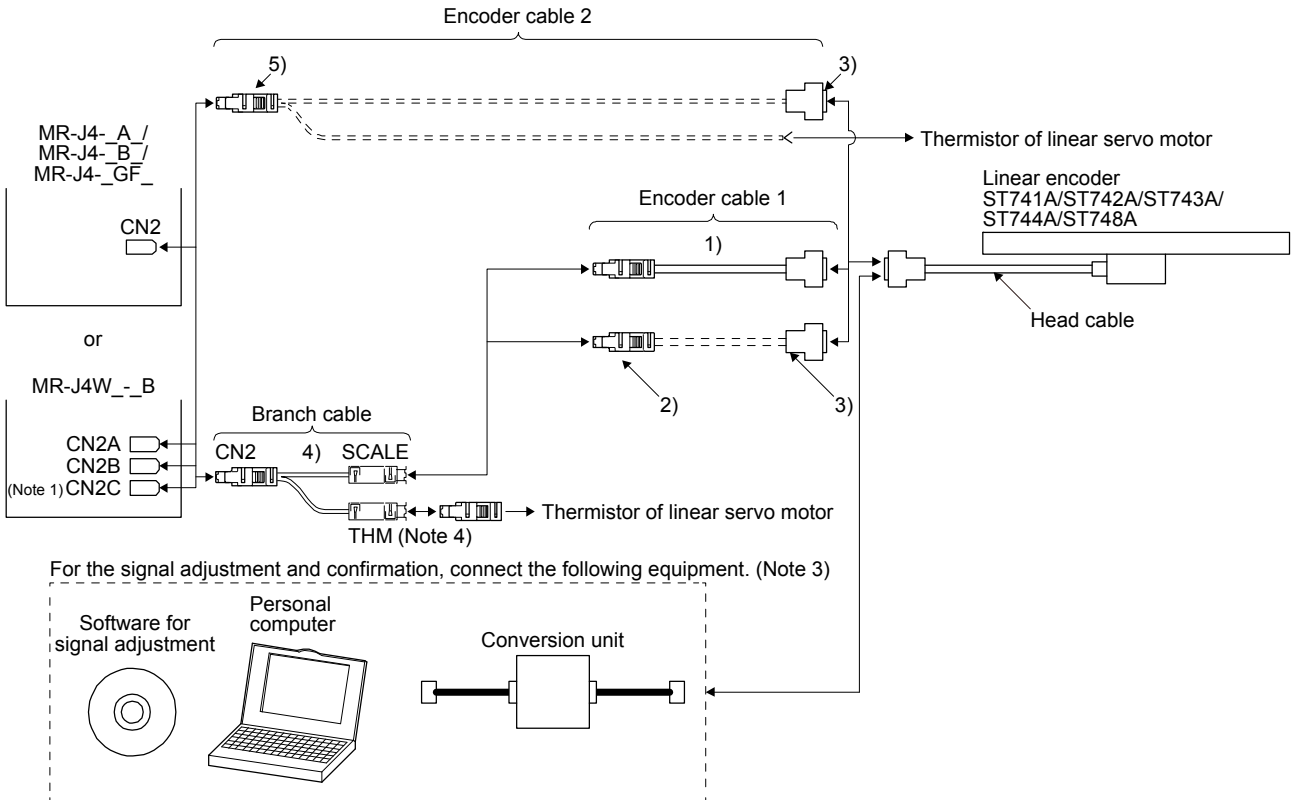

	Branch cable	Encoder cable	Head cable
When using an optional encoder cable	4) MR-J4THCBL03M (Refer to section 2.4.)	1) Options manufactured by Mitutoyo (Note 2) Part No.06ACF117A: 5 m Part No.06ACF117B: 10 m	Accessories for linear encoder Cable length: 1 m
When fabricating the encoder cable		2) Connector set MR-J3CN2 (Refer to (2) (a) of this section.)	3) Junction connector (Note 2) D-SUB (female) 15 pin Shell: HDAB-15S Plug case: HDA-CTH (manufactured by Hirose Electric)
When not using a branch cable		5) Connector set MR-J3CN2 (Refer to (2) (b) of this section.)	

- Note
1. The connection to CN2C is for the MR-J4 3-axis servo amplifier. MR-J4 2-axis servo amplifier does not have CN2C.
  2. It should be prepared by the customer.
  3. When mounting ST741A, ST742A, ST743A, ST744A or ST748A, a personal computer (with RS-232C port) for the signal adjustment and confirmation, and a software and conversion unit for signal adjustment are required. For details, contact Mitutoyo.
  4. For connectors for thermistor signals, change how to connect depending on the customer's system.

# 1. LINEAR ENCODER

## 2) MR-J4-\_A\_-RJ/MR-J4-\_B\_-RJ/MR-J4-\_GF\_-RJ

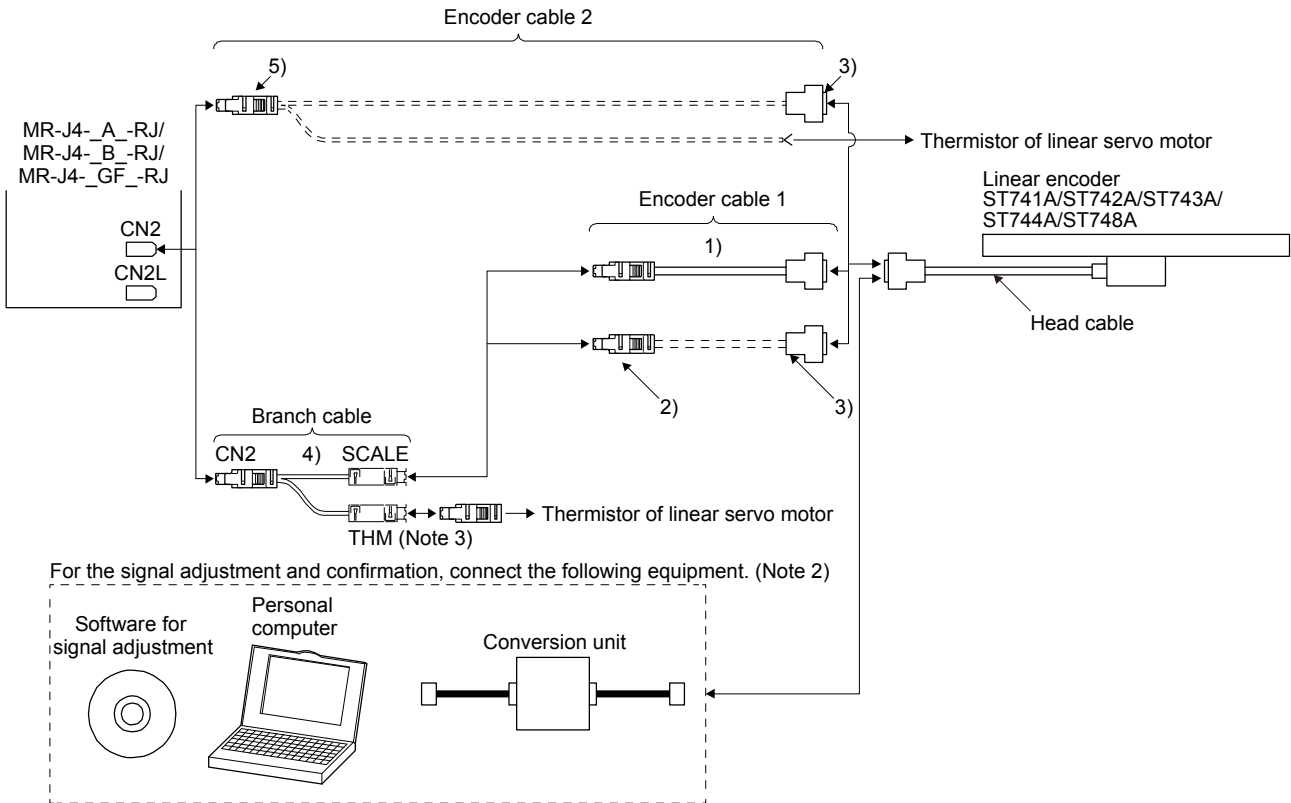

	Branch cable	Encoder cable		Head cable
When using an optional encoder cable	4) MR-J4THCBL03M (Refer to section 2.4.)	1) Options manufactured by Mitutoyo (Note 1) Part No.06ACF117A: 5 m Part No.06ACF117B: 10 m		Accessories for linear encoder Cable length: 1 m
When fabricating the encoder cable		2) Connector set MR-J3CN2 (Refer to (2) (a) of this section.)	3) Junction connector (Note 1) D-SUB15 pin (female) Shell: HDAB-15S Plug case: HDA-CTH (Hirose Electric)	
When not using a branch cable		5) Connector set MR-J3CN2 (Refer to (2) (b) of this section.)		

Note 1. It should be prepared by the customer.

2. When mounting ST741A, ST742A, ST743A, ST744A, or ST748A, a personal computer (with RS-232C port) for the signal adjustment and confirmation, and a software and conversion unit for signal adjustment are required. For details, contact Mitutoyo.

3. For connectors for thermistor signals, change how to connect depending on the customer's system.

# 1. LINEAR ENCODER

(b) For the fully closed loop system and scale measurement function

1) MR-J4-(DU)\_A\_/MR-J4-(DU)\_B\_/MR-J4-\_GF\_/MR-J4W2-\_B

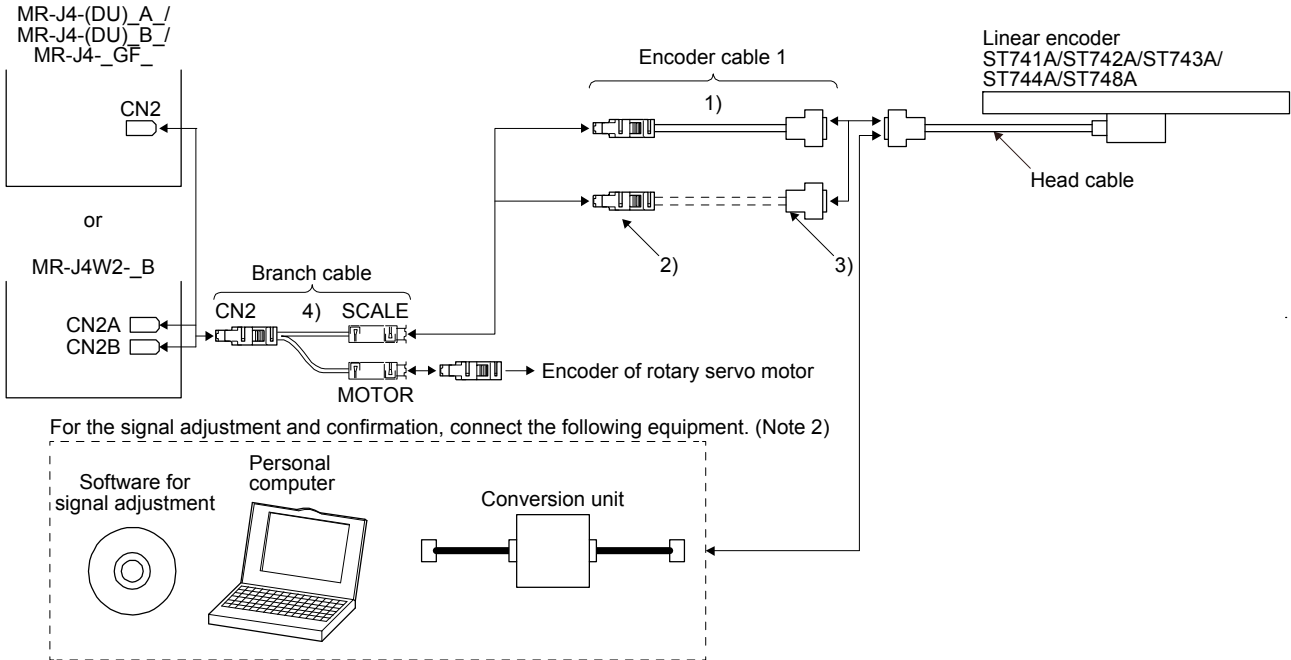

	Branch cable	Encoder cable		Head cable
When using an optional encoder cable	4) MR-J4FCCBL03M (Refer to section 2.5.)	1) Options manufactured by Mitutoyo (Note 1) Part No.06ACF117A: 5 m Part No.06ACF117B: 10 m		Accessories for linear encoder Cable length: 1 m
When fabricating the encoder cable		2) Connector set MR-J3CN2 (Refer to (2) (a) of this section.)	3) Junction connector (Note 1) D-SUB (female) 15 Pin shell: HDAB-15S Plug case: HDA-CTH (manufactured by Hirose Electric)	

Note 1. It should be prepared by the customer.

2. When mounting ST741A, ST742A, ST743A, ST744A or ST748A, a personal computer (with RS-232C port) for the signal adjustment and confirmation, and a software and conversion unit for signal adjustment are required. For details, contact Mitutoyo.

# 1. LINEAR ENCODER

## 2) MR-J4-(DU)\_A\_-RJ/MR-J4-(DU)\_B\_-RJ/MR-J4-\_GF\_-RJ

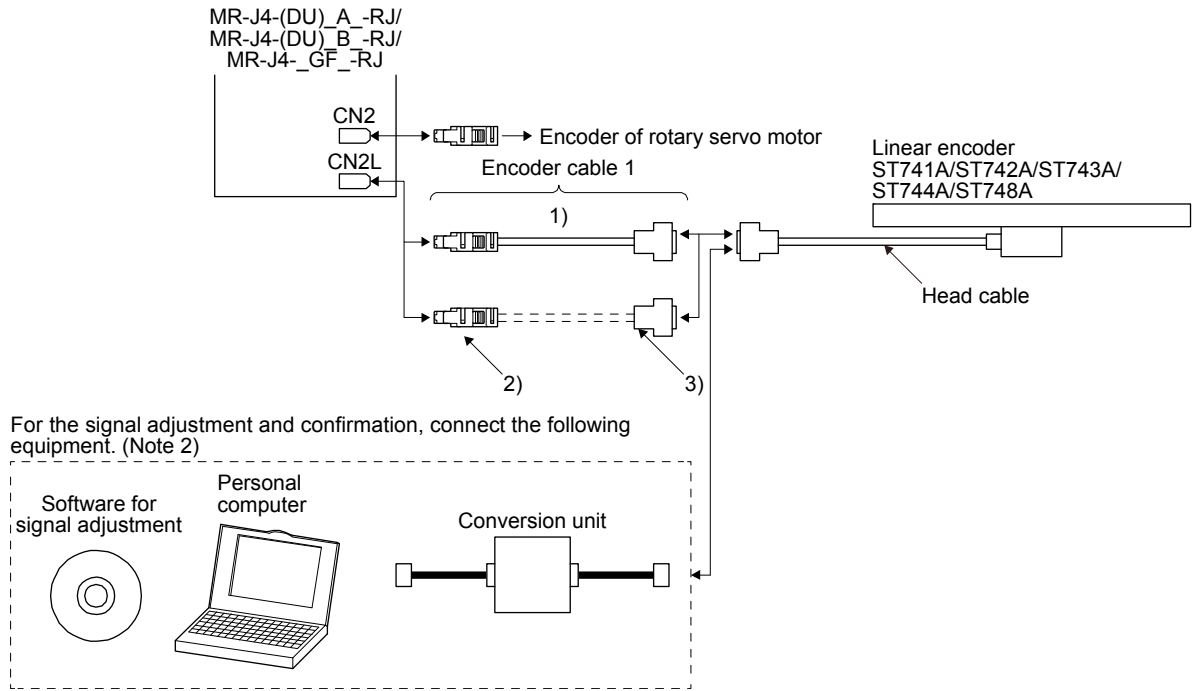

	Encoder cable		Head cable
When using an optional encoder cable	1) Options manufactured by Mitutoyo (Note 1) Part No.06ACF117A: 5 m Part No.06ACF117B: 10 m		Accessories for linear encoder Cable length: 1 m
When fabricating the encoder cable	2) Connector set MR-J3CN2 (Refer to (2) (a) of this section.)	3) Junction connector (Note 1) D-SUB (female) 15 pin Shell: HDAB-15S Plug case: HDA-CTH (manufactured by Hirose Electric)	

Note 1. It should be prepared by the customer.

2. When mounting ST741A, ST742A, ST743A or ST744A, a personal computer (with RS-232C port) for the signal adjustment and confirmation, and a software and conversion unit for signal adjustment are required. For details, contact Mitutoyo.

# 1. LINEAR ENCODER

## (2) Production of encoder cable

Produce the load side encoder cable using MR-J3CN2 or a junction connector as shown below. The encoder cable can be produced as the length of maximum 30 m.

### (a) Encoder cable 1

Connector set (option)  
MR-J3CN2  
Receptacle: 36210-0100PL  
Shell kit: 36310-3200-008  
(3M) (Note 2)

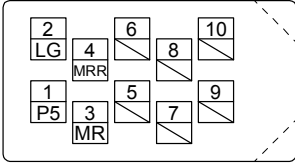

View seen from wiring side. (Note 3)

or

Connector set: 54599-1019  
(Molex) (Note 2)

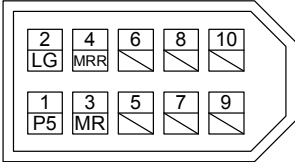

View seen from wiring side. (Note 3)

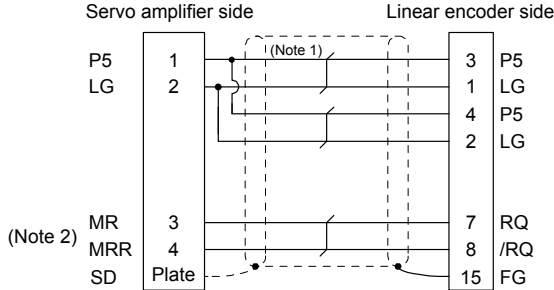

Shell: HDAB-15S  
Shield cover: HDA-CTH  
(Hirose Electric or equivalent)

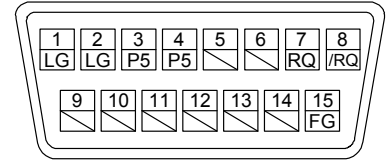

View seen from wiring side.

Note 1. We recommend the following specifications encoder cables.

Wiring length	Number of LG and P5 connections (when the head cable is 1 m or less)	Cable size
to 10 m	1-pair	AWG 22
to 20 m	2-pair	
to 30 m	3-pair	

2. For the CN2L connector, signals of pin 3 and pin 4 will be as follows.

Pin 3: MR2 Pin 4: MRR2

3. Do not connect anything to the pins shown as . Especially, pin 10 is for manufacturer adjustment. If it is connected with any other pin, the servo amplifier cannot operate normally. Referring to POINT of chapter 1, securely connect the external conductor of the shielded cable to the ground plate and fix it to the connector shell.

# 1. LINEAR ENCODER

## (b) Encoder cable 2

Connector set (option)  
MR-J3CN2  
Receptacle: 36210-0100PL  
Shell kit: 36310-3200-008  
(3M)

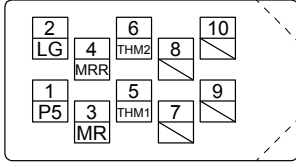

View seen from wiring side. (Note 3)

or

Connector set: 54599-1019  
(Molex)

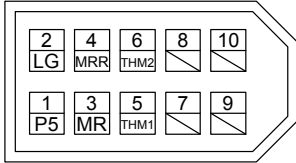

View seen from wiring side. (Note 3)

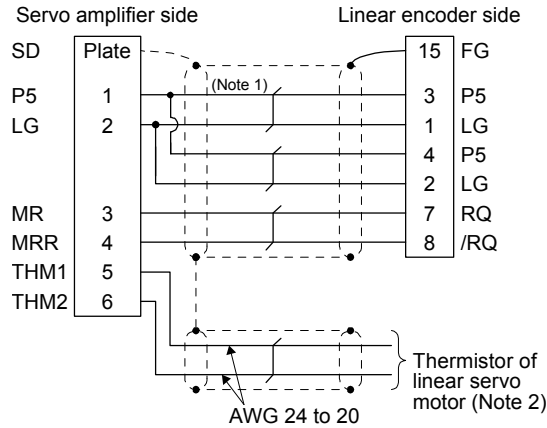

Shell: HDAB-15S  
Shield cover: HDA-CTH  
(Hirose Electric or equivalent)

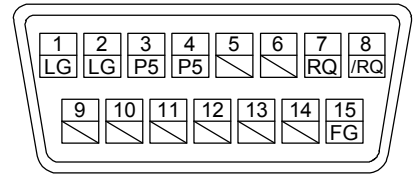

View seen from wiring side.

Note 1. We recommend the following specifications encoder cables.

Wiring length	Number of LG and P5 connections (when the head cable is 1 m or less)	Cable size
to 10 m	1-pair	AWG 22
to 20 m	2-pair	
to 30 m	3-pair	

- For wiring to the thermistor of the linear servo motor, refer to "Linear Servo Motor Instruction Manual".
- Do not connect anything to the pins shown as . Especially, pin 10 is for manufacturer adjustment. If it is connected with any other pin, the servo amplifier cannot operate normally. Referring to POINT of chapter 1, securely connect the external conductor of the shielded cable to the ground plate and fix it to the connector shell.

# 1. LINEAR ENCODER

## 1.2.4 ST1341A/ST1342A

### (1) Cable structure

Prepare a cable based on the following configuration diagram.

#### (a) For the linear servo motor

- 1) MR-J4-\_A\_/MR-J4-\_B\_/MR-J4-\_GF\_/MR-J4W\_-\_B

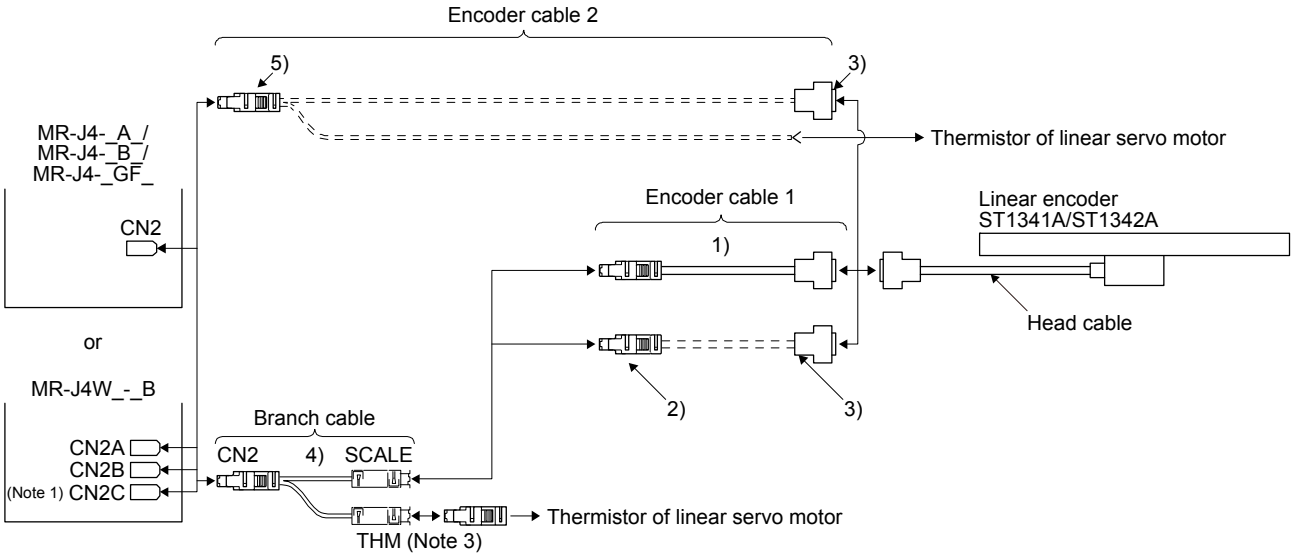

	Branch cable	Encoder cable	Head cable
When using an optional encoder cable	4) MR-J4THCBL03M (Refer to section 2.4.)	1) Options manufactured by Mitutoyo (Note 2) Part No.06ACF117A: 5 m Part No.06ACF117B: 10 m	
When fabricating the encoder cable		2) Connector set MR-J3CN2 (Refer to (2) (a) of this section.)	3) Junction connector (Note 2) D-SUB (female) 15 pin Shell: HDAB-15S Plug case: HDA-CTH (Hirose Electric)
When not using a branch cable		5) Connector set MR-J3CN2 (Refer to (2) (b) of this section.)	

- Note
1. The connection to CN2C is for the MR-J4 3-axis servo amplifier. MR-J4 2-axis servo amplifier does not have CN2C.
  2. It should be prepared by the customer.
  3. For connectors for thermistor signals, change how to connect depending on the customer's system.

# 1. LINEAR ENCODER

## 2) MR-J4- \_A\_-RJ/MR-J4- \_B\_-RJ/MR-J4- \_GF\_-RJ

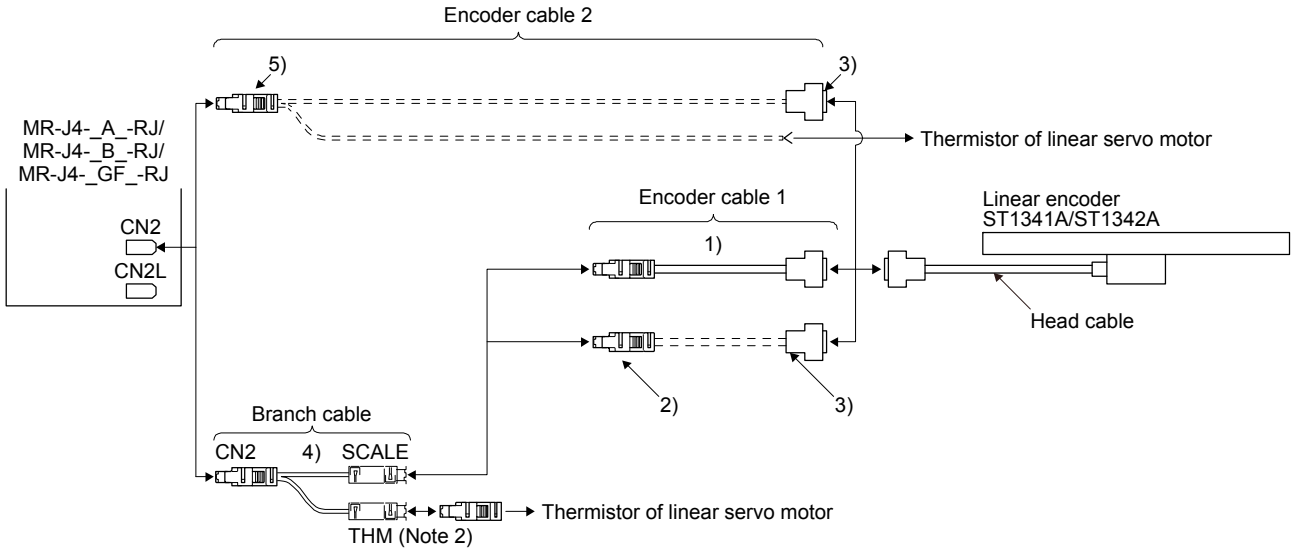

	Branch cable	Encoder cable		Head cable
When using an optional encoder cable	4) MR-J4THCBL03M (Refer to section 2.4.)	1) Options manufactured by Mitutoyo (Note 1) Part No.06ACF117A: 5 m Part No.06ACF117B: 10 m		Accessories for linear encoder Cable length: 1 m
When fabricating the encoder cable		2) Connector set MR-J3CN2 (Refer to (2) (a) of this section.)	3) Junction connector (Note 1) D-SUB15 pin (female) Shell: HDAB-15S Plug case: HDA-CTH (Hirose Electric)	
When not using a branch cable		5) Connector set MR-J3CN2 (Refer to (2) (b) of this section.)		

Note 1. It should be prepared by the customer.

2. For connectors for thermistor signals, change how to connect depending on the customer's system.

# 1. LINEAR ENCODER

(b) For the fully closed loop system and scale measurement function

1) MR-J4-(DU)\_A\_/MR-J4-(DU)\_B\_/MR-J4-\_GF\_/MR-J4W2-\_B

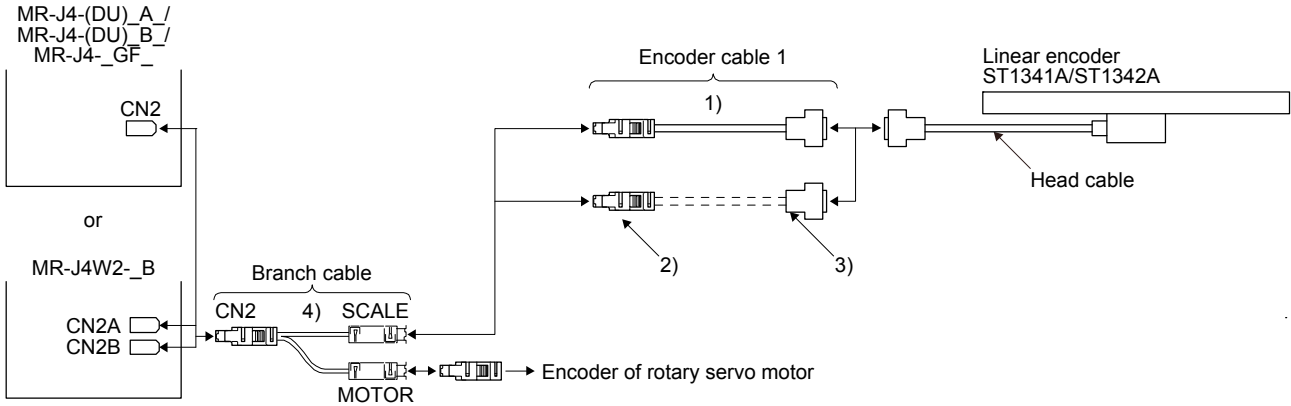

	Branch cable	Encoder cable		Head cable
When using an optional encoder cable	4) MR-J4FCCBL03M (Refer to section 2.5.)	1) Options manufactured by Mitutoyo (Note) Part No.06ACF117A: 5 m Part No.06ACF117B: 10 m		Accessories for linear encoder Cable length: 1 m
When fabricating the encoder cable		2) Connector set MR-J3CN2 (Refer to (2) (a) of this section.)	3) Junction connector (Note) D-SUB (female) 15 Pin shell: HDAB-15S Plug case: HDA-CTH (manufactured by Hirose Electric)	

Note. It should be prepared by the customer.

2) MR-J4-(DU)\_A\_-RJ/MR-J4-(DU)\_B\_-RJ/MR-J4-\_GF\_-RJ

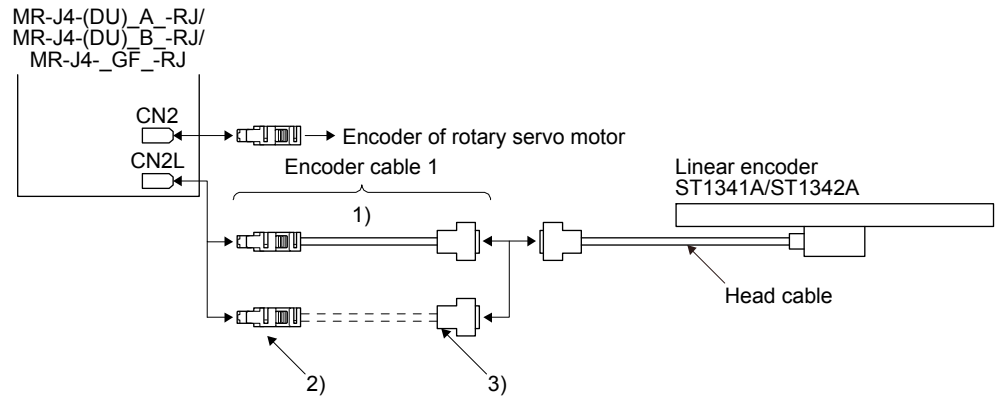

	Encoder cable		Head cable
When using an optional encoder cable	1) Options manufactured by Mitutoyo (Note) Part No.06ACF117A: 5 m Part No.06ACF117B: 10 m		Accessories for linear encoder Cable length: 1 m
When fabricating the encoder cable	2) Connector set MR-J3CN2 (Refer to (2) (a) of this section.)	3) Junction connector (Note) D-SUB (female) 15 pin Shell: HDAB-15S Plug case: HDA-CTH (manufactured by Hirose Electric)	

Note. It should be prepared by the customer.

# 1. LINEAR ENCODER

## (2) Production of encoder cable

Produce the load side encoder cable using MR-J3CN2 or a junction connector as shown below. The encoder cable can be produced as the length of maximum 30 m.

### (a) Encoder cable 1

Connector set (option)  
MR-J3CN2  
Receptacle: 36210-0100PL  
Shell kit: 36310-3200-008  
(3M) (Note 2)

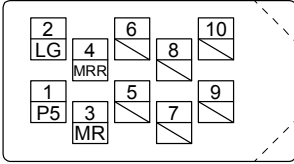

View seen from wiring side. (Note 3)

or

Connector set: 54599-1019  
(Molex) (Note 2)

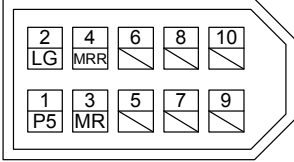

View seen from wiring side. (Note 3)

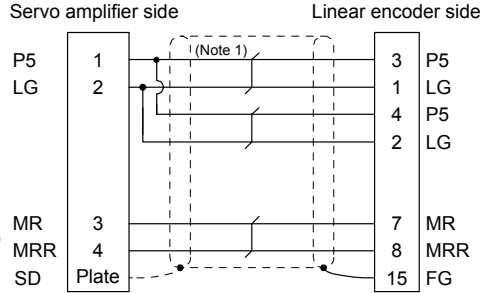

Shell: HDAB-15S  
Shield cover: HDA-CTH  
(Hirose Electric or equivalent)

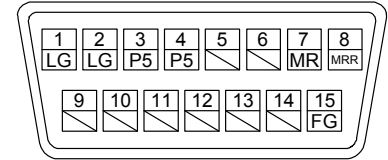

View seen from wiring side.

Note 1. We recommend the following specifications encoder cables.

Wiring length	Number of LG and P5 connections (when the head cable is 1 m or less)	Cable size
to 10 m	1-pair	AWG 22
to 20 m	2-pair	
to 30 m	3-pair	

2. For the CN2L connector, signals of pin 3 and pin 4 will be as follows.

Pin 3: MR2 Pin 4: MRR2

3. Do not connect anything to the pins shown as . Especially, pin 10 is for manufacturer adjustment. If it is connected with any other pin, the servo amplifier cannot operate normally. Referring to POINT of chapter 1, securely connect the external conductor of the shielded cable to the ground plate and fix it to the connector shell.

# 1. LINEAR ENCODER

## (b) Encoder cable 2

Connector set (option)  
MR-J3CN2  
Receptacle: 36210-0100PL  
Shell kit: 36310-3200-008  
(3M)

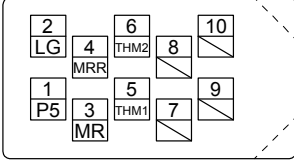

View seen from wiring side. (Note 3)

or

Connector set: 54599-1019  
(Molex)

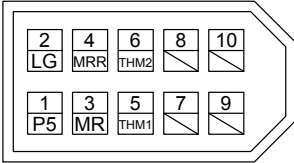

View seen from wiring side. (Note 3)

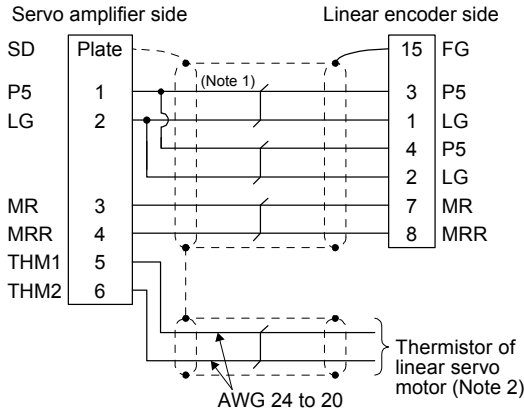

Shell: HDAB-15S  
Shield cover: HDA-CTH  
(Hirose Electric or equivalent)

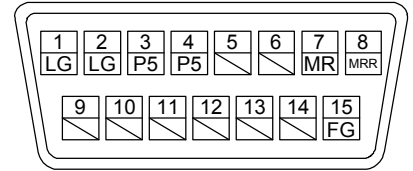

View seen from wiring side.

Note 1. We recommend the following specifications encoder cables.

Wiring length	Number of LG and P5 connections (when the head cable is 1 m or less)	Cable size
to 10 m	1-pair	AWG 22
to 20 m	2-pair	
to 30 m	3-pair	

- For wiring to the thermistor of the linear servo motor, refer to "Linear Servo Motor Instruction Manual".
- Do not connect anything to the pins shown as . Especially, pin 10 is for manufacturer adjustment. If it is connected with any other pin, the servo amplifier cannot operate normally. Referring to POINT of chapter 1, securely connect the external conductor of the shielded cable to the ground plate and fix it to the connector shell.

# 1. LINEAR ENCODER

---

## 1.3 Linear encoder manufactured by Heidenhain

POINT	
	●When the absolute position detection system is configured, the absolute position battery is not required.

### 1.3.1 LC 495M/LC 195M (absolute type)

POINT	
	<ul style="list-style-type: none"><li>●This linear encoder is of four-wire type. When using this linear encoder, change the parameter to select the four-wire type. For changing parameters, refer to each servo amplifier instruction manual.</li><li>●When using a linear encoder of four-wire type with fully closed loop control, use an MR-J4-(DU)_A_-RJ/MR-J4-(DU)_B_-RJ.</li><li>●When using a linear encoder of four-wire type with scale measurement function, use an MR-J4-(DU)_B_-RJ.</li></ul>

# 1. LINEAR ENCODER

## (1) Cable composition

Prepare a cable based on the following configuration diagram.

### (a) For the linear servo motor

#### 1) MR-J4-\_A\_/MR-J4-\_B\_/MR-J4-\_GF\_/MR-J4W\_-\_B

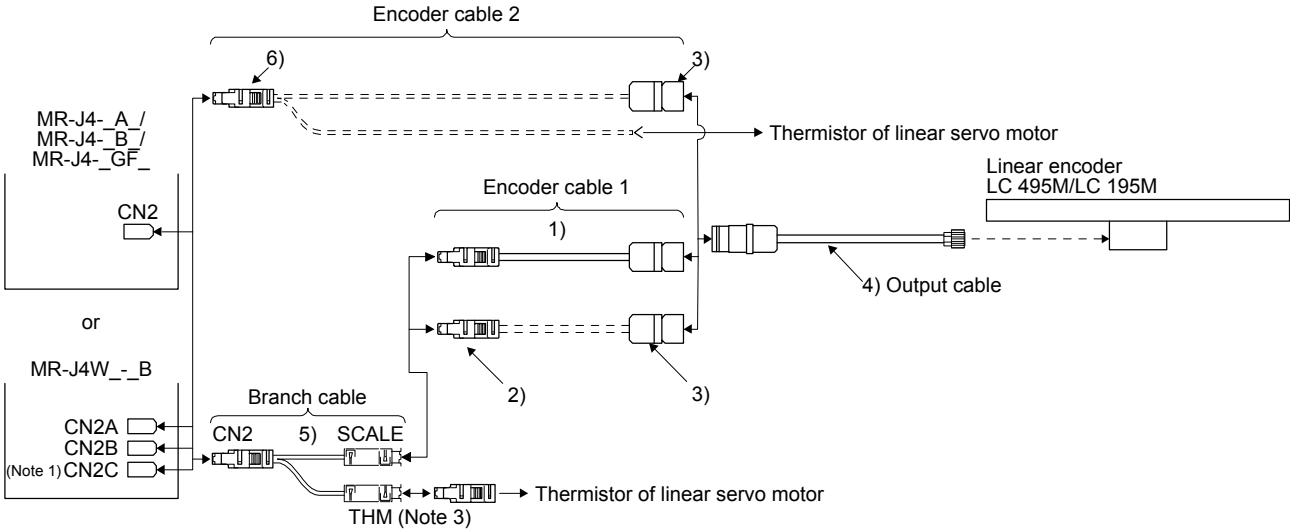

	Branch cable	Encoder cable		Output cable
				LC 495M/LC 195M
When using an optional encoder cable	5) MR-J4THCBL03M (Refer to section 2.4.)	1) Options manufactured by Heidenhain (Note 2) 573661-xx_m		4) 547300-xx_m (Heidenhain) (Note 2)
When fabricating the encoder cable		2) Connector set MR-J3CN2 (Refer to (2) (a) of this section.)	3) Junction connector (Note 2) 17-pin coupling (female) 291697-26 (Heidenhain)	
When not using a branch cable		6) Connector set MR-J3CN2 (Refer to (2) (b) of this section.)		

Note 1. The connection to CN2C is for the MR-J4 3-axis servo amplifier. MR-J4 2-axis servo amplifier does not have CN2C.

2. It should be prepared by the customer.

3. For connectors for thermistor signals, change how to connect depending on the customer's system.

# 1. LINEAR ENCODER

## 2) MR-J4-\_A\_-RJ/MR-J4-\_B\_-RJ/MR-J4-\_GF\_-RJ

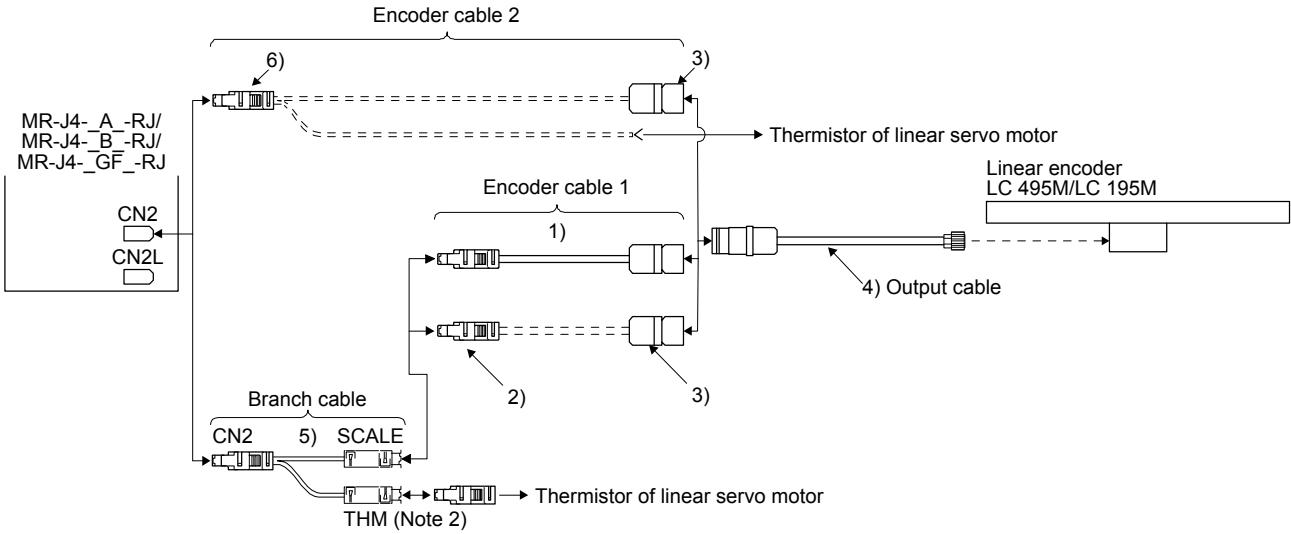

	Branch cable	Encoder cable		Output cable
				LC 495M/LC 195M
When using an optional encoder cable	5) MR-J4THCBL03M (Refer to section 2.4.)	1) Options manufactured by Heidenhain (Note 1) 573661-xx_m		4) 547300-xx_m (Heidenhain) (Note 1)
When fabricating the encoder cable		2) Connector set MR-J3CN2 (Refer to (2) (a) of this section.)	3) Junction connector (Note 1) 17-pin coupling (female) 291697-26 (Heidenhain)	
When not using a branch cable		6) Connector set MR-J3CN2 (Refer to (2) (b) of this section.)		

Note 1. It should be prepared by the customer.

2. For connectors for thermistor signals, change how to connect depending on the customer's system.

### (b) When using for fully closed loop system and scale measurement function

#### MR-J4-(DU)\_A\_-RJ/MR-J4-(DU)\_B\_-RJ/MR-J4-\_GF\_-RJ

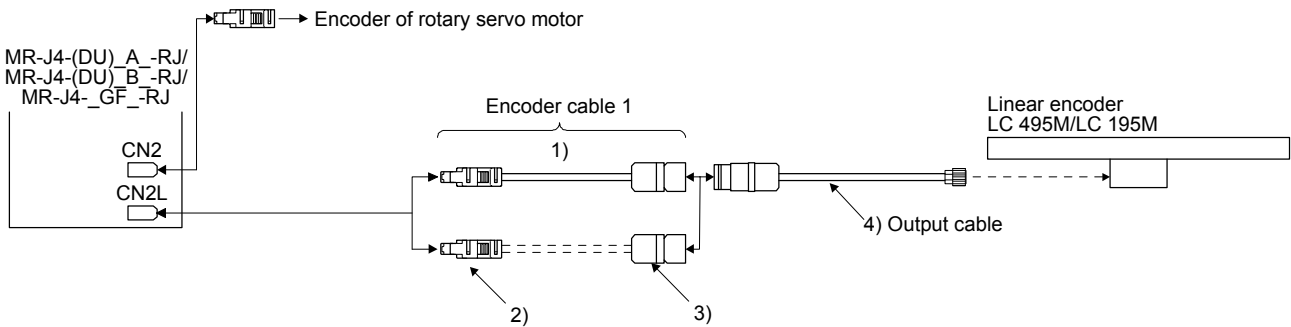

	Encoder cable		Output cable
			LC 495M/LC 195M
When using an optional encoder cable	1) Options manufactured by Heidenhain (Note 1) 573661-xx_m		4) 547300-xx_m (Heidenhain) (Note)
When fabricating the encoder cable	2) Connector set MR-J3CN2 (Refer to (2) (a) of this section.)	3) Junction connector (Note) 17-pin coupling (female) 291697-26 (Heidenhain)	

Note. It should be prepared by the customer.

# 1. LINEAR ENCODER

## (2) Production of encoder cable

Produce the encoder cable using MR-J3CN2 or a junction connector as shown below. The encoder cable can be produced as the length of maximum 30 m.

### (a) Encoder cable 1

Connector set (option)  
MR-J3CN2  
Receptacle: 36210-0100PL  
Shell kit: 36310-3200-008  
(3M) (Note 2)

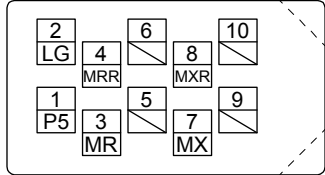

View seen from wiring side. (Note 3)

or  
Connector set: 54599-1019  
(Molex) (Note 2)

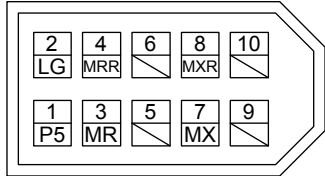

View seen from wiring side. (Note 3)

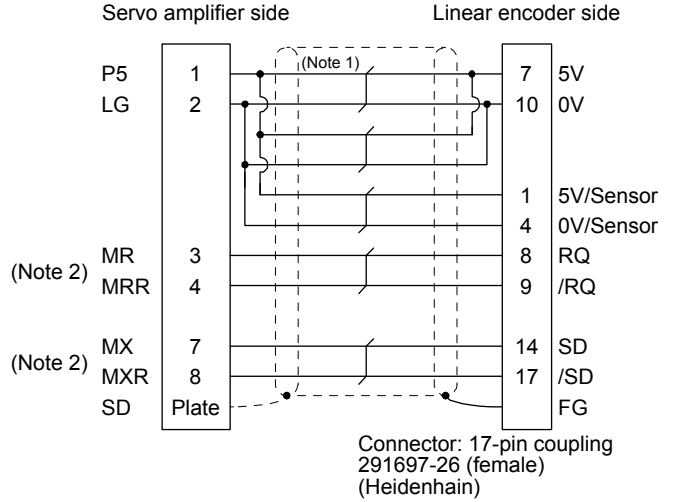

Note 1. We recommend the following specifications encoder cables.

Wiring length	Number of LG and P5 connections (when the output cable is 1 m or less)	Cable size
to 10 m	1-pair	AWG 22
to 20 m	2-pair	
to 30 m	3-pair	

2. For the CN2L connector, signals of pin 3, pin 4, pin 7, and pin 8 will be as follows.

Pin 3: MR2 Pin 4: MRR2 Pin 7: MX2 Pin 8: MXR2

3. Do not connect anything to the pins shown as . Especially, pin 10 is for manufacturer adjustment. If it is connected with any other pin, the servo amplifier cannot operate normally.

Referring to POINT of chapter 1, securely connect the external conductor of the shielded cable to the ground plate and fix it to the connector shell.

# 1. LINEAR ENCODER

## (b) Encoder cable 2

Connector set (option)  
MR-J3CN2  
Receptacle: 36210-0100PL  
Shell kit: 36310-3200-008  
(3M)

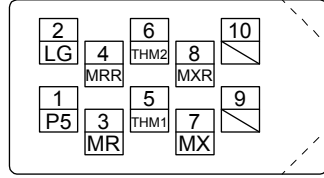

View seen from wiring side. (Note 3)

or

Connector set: 54599-1019  
(Molex)

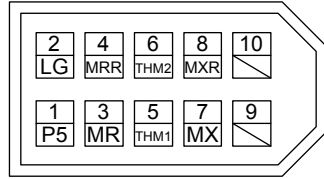

View seen from wiring side. (Note 3)

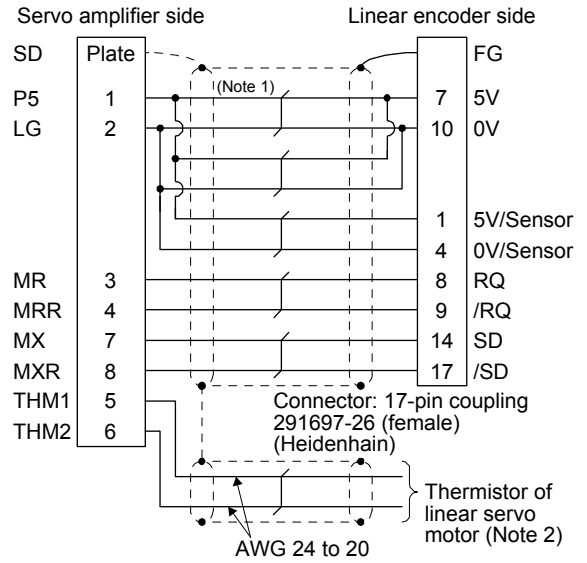

Note 1. We recommend the following specifications encoder cables.

Wiring length	Number of LG and P5 connections (when the output cable is 1 m or less)	Cable size
to 10 m	1-pair	AWG 22
to 20 m	2-pair	
to 30 m	3-pair	

- For wiring to the thermistor of the linear servo motor, refer to "Linear Servo Motor Instruction Manual".
- Do not connect anything to the pins shown as . Especially, pin 10 is for manufacturer adjustment. If it is connected with any other pin, the servo amplifier cannot operate normally. Referring to POINT of chapter 1, securely connect the external conductor of the shielded cable to the ground plate and fix it to the connector shell.

# 1. LINEAR ENCODER

---

## 1.3.2 LIC 4193M/LIC 4195M/LIC 4197M/LIC 4199M/LIC 2197M/LIC 2199M

POINT
<ul style="list-style-type: none"><li>● These linear encoders have two-wire type and four-wire type. When using a four-wire type linear encoder, change the parameter to select the four-wire type. For changing parameters, refer to each servo amplifier instruction manual.</li><li>● When using a linear encoder of four-wire type with fully closed loop control, use an MR-J4-(DU)_A_-RJ, MR-J4-(DU)_B_-RJ, or MR-J4-_GF_-RJ.</li><li>● When using a linear encoder of four-wire type with scale measurement function, use an MR-J4-(DU)_B_-RJ or MR-J4-_GF_-RJ.</li></ul>

# 1. LINEAR ENCODER

## (1) Cable structure

Prepare a cable based on the following configuration diagram.

### (a) For the linear servo motor

#### 1) MR-J4- \_A\_ /MR-J4- \_B\_ /MR-J4- \_GF\_ /MR-J4W\_ -\_B

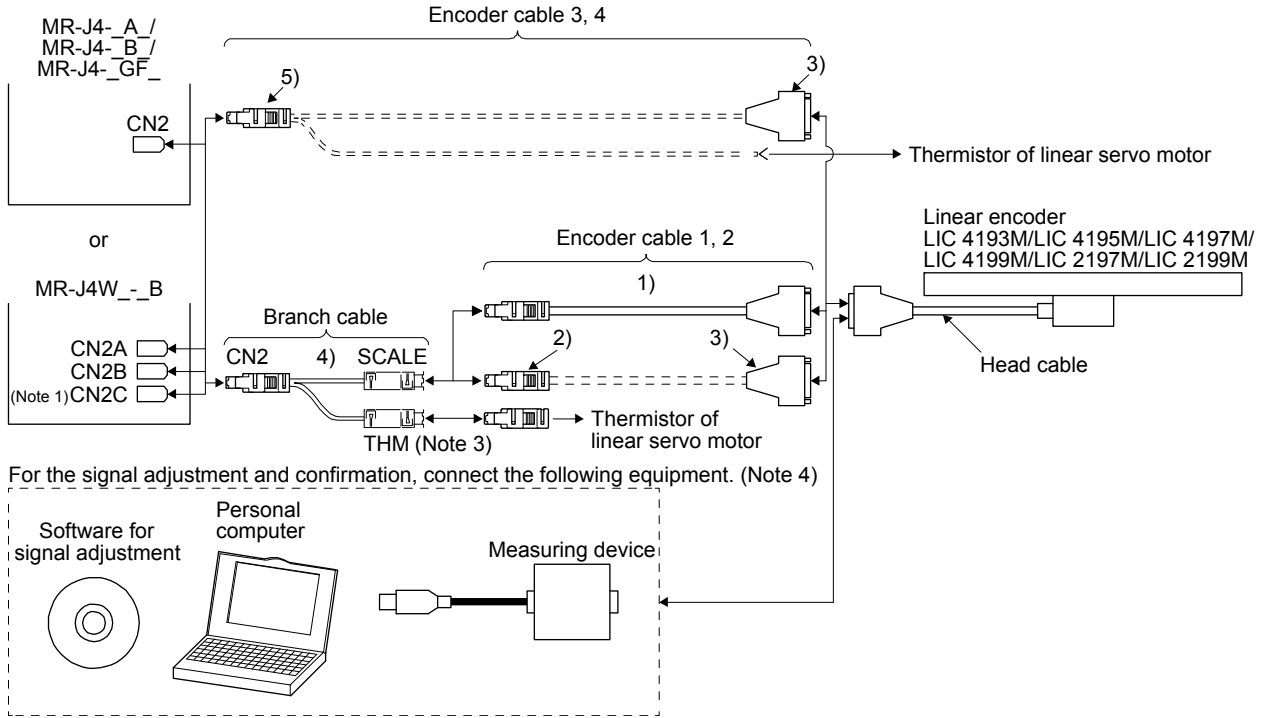

	branch cable	Encoder cable		Head cable
When using an optional encoder cable	4) MR-J4THCBL03M (Refer to section 2.4.)	1) Options manufactured by Heidenhain (Note 2) 630 856-xx _m		Accessories for linear encoder Cable length: 1 m
When fabricating the encoder cable		2) Connector set MR-J3CN2 (Refer to (2) (a), (b) of this section.)	3) Junction connector (Note 2) D-SUB15 pin (female)	
When not using a branch cable		5) Connector set MR-J3CN2 (Refer to (2) (c), (d) of this section.)		

- Note 1. The connection to CN2C is for the MR-J4 3-axis servo amplifier. MR-J4 2-axis servo amplifier does not have CN2C.
2. It should be prepared by the customer.
3. For connectors for thermistor signals, change how to connect depending on the customer's system.
4. When you mount LIC 4193M, LIC 4195M, LIC 4197M, LIC 4199M, LIC 2197M, or LIC 2199M, a personal computer (with a USB port) for the signal adjustment and confirmation, and a software and measuring device for signal adjustment are required. For details, contact Heidenhain.

# 1. LINEAR ENCODER

## 2) MR-J4-\_A\_-RJ/MR-J4-\_B\_-RJ/MR-J4-\_GF\_-RJ

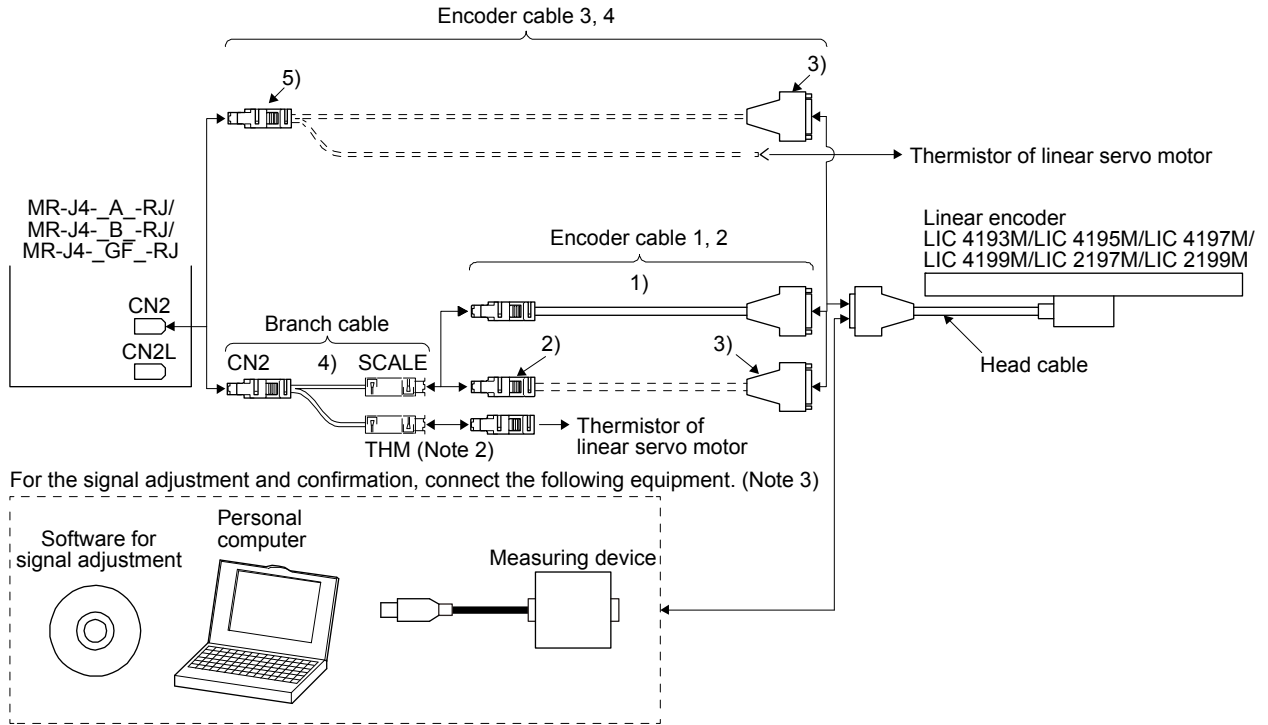

	branch cable	Encoder cable	Head cable
When using an optional encoder cable	4) MR-J4THCBL03M (Refer to section 2.4.)	1) Options manufactured by Heidenhain (Note 1) 630 856-xx _m	Accessories for linear encoder Cable length: 1 m
When fabricating the encoder cable		2) Connector set MR-J3CN2 (Refer to (2) (a), (b) of this section.)	
When not using a branch cable		5) Connector set MR-J3CN2 (Refer to (2) (c), (d) of this section.)	

- Note 1. It should be prepared by the customer.
2. For connectors for thermistor signals, change how to connect depending on the customer's system.
3. When you mount LIC 4193M, LIC 4195M, LIC 4197M, LIC 4199M, LIC 2197M, or LIC 2199M, a personal computer (with a USB port) for the signal adjustment and confirmation, and a software and measuring device for signal adjustment are required. For details, contact Heidenhain.

# 1. LINEAR ENCODER

(b) When using for fully closed loop system and scale measurement function

1) MR-J4-(DU)\_A\_/MR-J4-(DU)\_B\_/MR-J4-\_GF\_/MR-J4W2-\_B (two-wire type only)

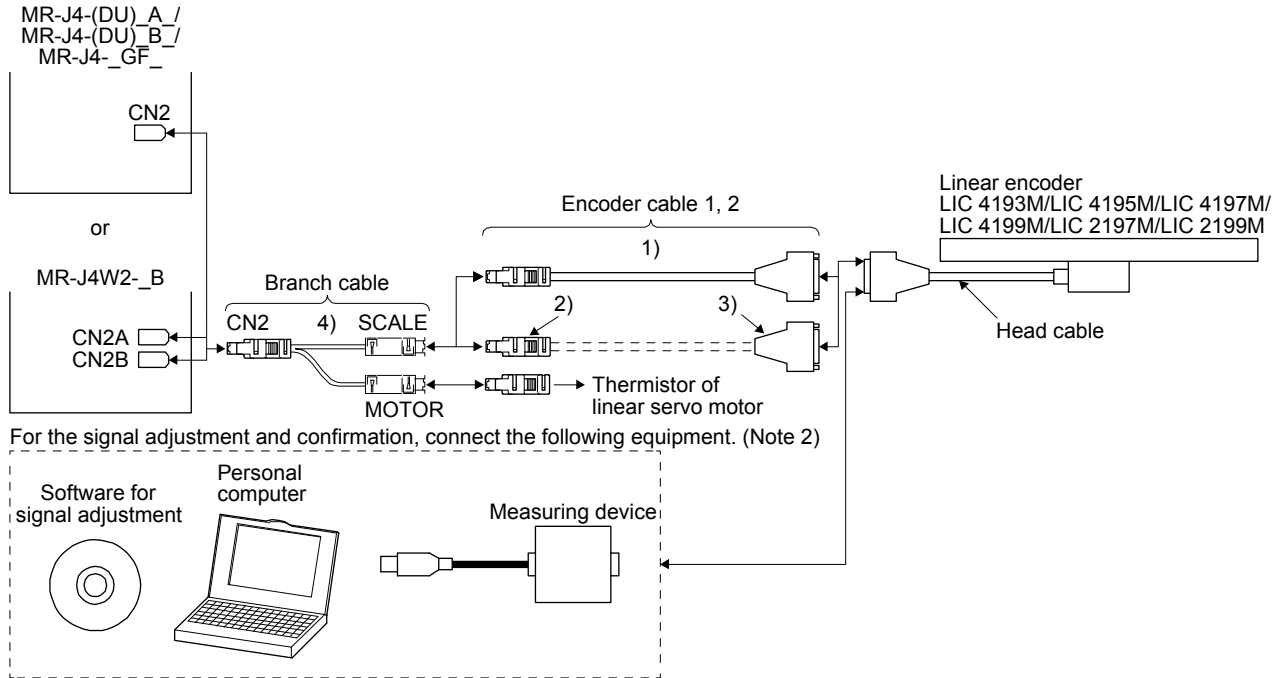

	branch cable	Encoder cable		Head cable
When using an optional encoder cable	4) MR-J4FCCBL03M (Refer to section 2.5.)	1) Options manufactured by Heidenhain (Note 1) 630 856-xx_m		Accessories for linear encoder Cable length: 1 m
When fabricating the encoder cable		2) Connector set MR-J3CN2 (Refer to (2) (a) in this section.)	3) Junction connector (Note 1) D-SUB15 pin (female)	

Note 1. It should be prepared by the customer.

2. When you mount LIC 4193M, LIC 4195M, LIC 4197M, LIC 4199M, LIC 2197M, or LIC 2199M, a personal computer (with a USB port) for the signal adjustment and confirmation, and a software and measuring device for signal adjustment are required. For details, contact Heidenhain.

# 1. LINEAR ENCODER

2) MR-J4-\_A\_-RJ/MR-J4-\_B\_-RJ servo amplifier or MR-J4-DU\_A\_-RJ/MR-J4-DU\_B\_-RJ drive unit

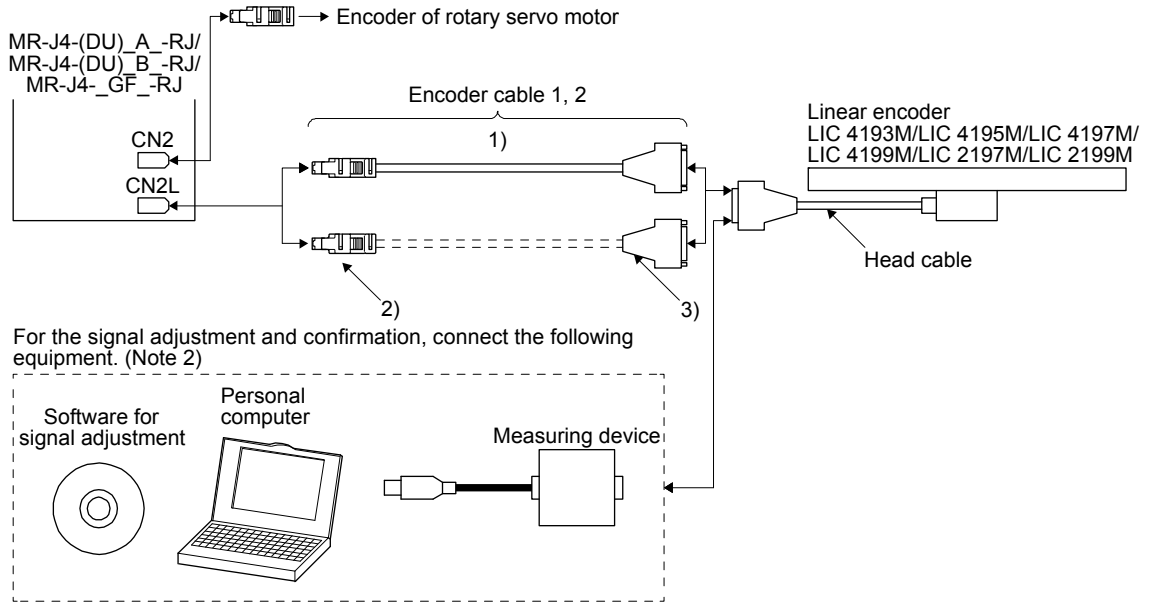

	Encoder cable	Head cable
When using an optional encoder cable	1) Options manufactured by Heidenhain (Note 1) 630 856-xx_m	Accessories for linear encoder Cable length: 1 m
When fabricating the encoder cable	2) Connector set MR-J3CN2 (Refer to (2) (a), (b) of this section.)	3) Junction connector (Note 1) D-SUB15 pin (female)

Note 1. It should be prepared by the customer.

Note 2. When you mount LIC 4193M, LIC 4195M, LIC 4197M, LIC 4199M, LIC 2197M, or LIC 2199M, a personal computer (with a USB port) for the signal adjustment and confirmation, and a software and measuring device for signal adjustment are required. For details, contact Heidenhain.

# 1. LINEAR ENCODER

## (2) Fabrication of the encoder cable

Produce the load-side encoder cable using MR-J3CN2 or a junction connector as shown below. The encoder cable can be produced as the length of maximum 30 m.

### (a) Encoder cable 1 (two-wire type)

Connector set (optional)  
MR-J3CN2  
Receptacle: 36210-0100PL  
Shell kit: 36310-3200-008  
(3M) (Note 2)

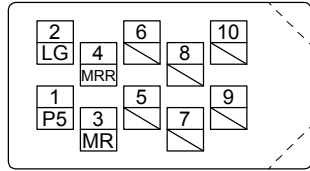

View seen from the wiring side. (Note 3)

or

Connector set: 54599-1019  
(Molex) (Note 2)

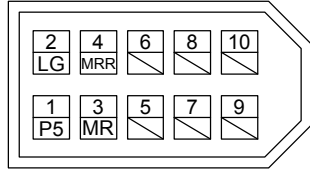

View seen from the wiring side. (Note 3)

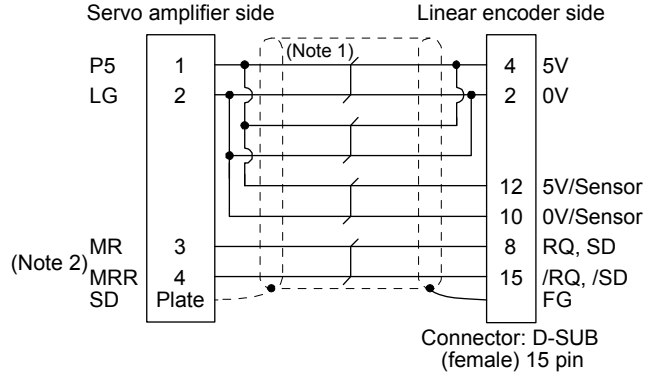

Note 1. We recommend the following specifications encoder cables.

Wiring length	Number of LG and P5 connections	Wire size
to 5 m	1-pair	AWG 22
to 10 m	2-pair	
to 20 m	3-pair	
to 30 m	4-pair	

2. For the CN2L connector, signals of pin 3 and pin 4 will be as follows.

Pin 3: MR2

Pin 4: MRR2

3. Do not connect anything to the pins shown as . Especially, pin 10 is for manufacturer adjustment. If it is connected with any other pin, the servo amplifier cannot operate normally. Referring to POINT of chapter 1, securely connect the external conductor of the shielded cable to the ground plate and fix it to the connector shell.

# 1. LINEAR ENCODER

## (b) Encoder cable 2 (four-wire type)

Connector set (optional)  
MR-J3CN2  
Receptacle: 36210-0100PL  
Shell kit: 36310-3200-008  
(3M) (Note 2)

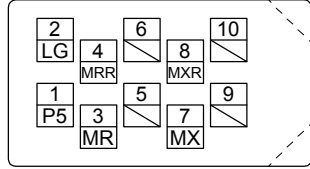

View seen from the wiring side. (Note 3)

or

Connector set: 54599-1019  
(Molex) (Note 2)

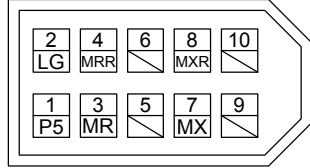

View seen from the wiring side. (Note 3)

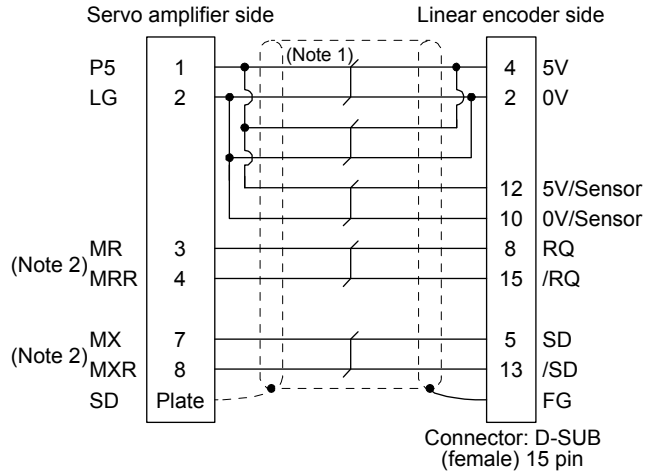

Note 1. We recommend the following specifications encoder cables.

Wiring length	Number of LG and P5 connections	Wire size
to 5 m	1-pair	AWG 22
to 10 m	2-pair	
to 20 m	3-pair	
to 30 m	4-pair	

2. For the CN2L connector, signals of pin 3, pin 4, pin 7, and pin 8 will be as follows.

- Pin 3: MR2
- Pin 4: MRR2
- Pin 7: MX2
- Pin 8: MXR2

3. Do not connect anything to the pins shown as . Especially, pin 10 is for manufacturer adjustment. If it is connected with any other pin, the servo amplifier cannot operate normally. Referring to POINT of chapter 1, securely connect the external conductor of the shielded cable to the ground plate and fix it to the connector shell.

# 1. LINEAR ENCODER

## (c) Encoder cable 3 (two-wire type)

Connector set (optional)  
 MR-J3CN2  
 Receptacle: 36210-0100PL  
 Shell kit: 36310-3200-008  
 (3M)

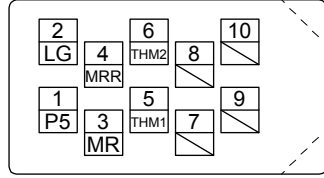

View seen from the wiring side. (Note 3)

or

Connector set: 54599-1019  
 (Molex)

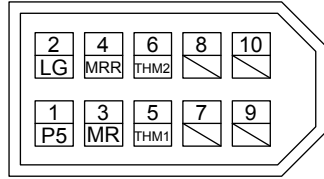

View seen from the wiring side. (Note 3)

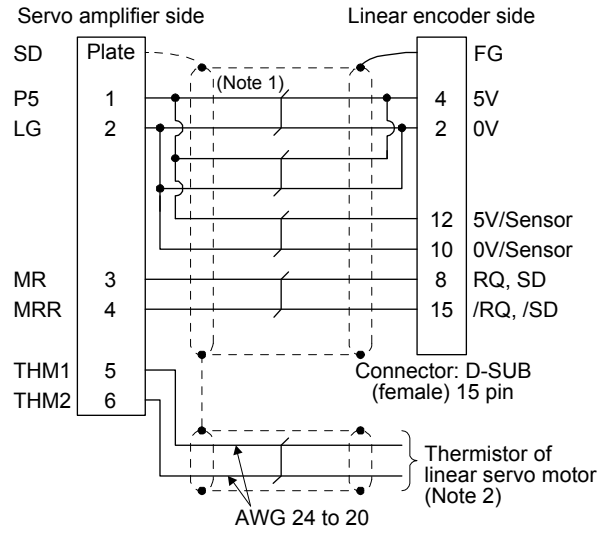

Note 1. We recommend the following specifications encoder cables.

Wiring length	Number of LG and P5 connections	Wire size
to 5 m	1-pair	AWG 22
to 10 m	2-pair	
to 20 m	3-pair	
to 30 m	4-pair	

- For wiring to the thermistor of the linear servo motor, refer to "Linear Servo Motor Instruction Manual".
- Do not connect anything to the pins shown as . Especially, pin 10 is for manufacturer adjustment. If it is connected with any other pin, the servo amplifier cannot operate normally. Referring to POINT of chapter 1, securely connect the external conductor of the shielded cable to the ground plate and fix it to the connector shell.

# 1. LINEAR ENCODER

## (d) Encoder cable 4 (four-wire type)

Connector set (optional)  
 MR-J3CN2  
 Receptacle: 36210-0100PL  
 Shell kit: 36310-3200-008  
 (3M)

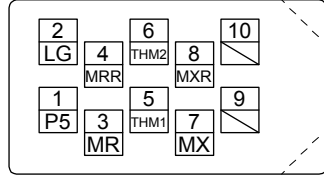

View seen from the wiring side. (Note 3)

or

Connector set: 54599-1019  
 (Molex)

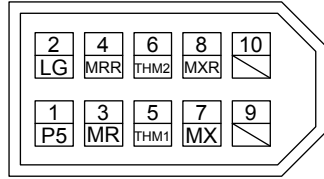

View seen from the wiring side. (Note 3)

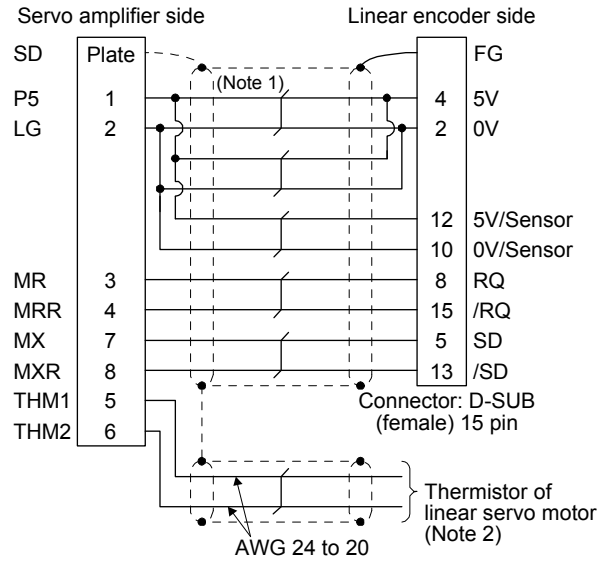

Note 1. We recommend the following specifications encoder cables.

Wiring length	Number of LG and P5 connections	Wire size
to 5 m	1-pair	AWG 22
to 10 m	2-pair	
to 20 m	3-pair	
to 30 m	4-pair	

- For wiring to the thermistor of the linear servo motor, refer to "Linear Servo Motor Instruction Manual".
- Do not connect anything to the pins shown as . Especially, pin 10 is for manufacturer adjustment. If it is connected with any other pin, the servo amplifier cannot operate normally. Referring to POINT of chapter 1, securely connect the external conductor of the shielded cable to the ground plate and fix it to the connector shell.

# 1. LINEAR ENCODER

---

## 1.3.3 LIDA 483/LIDA 485/LIDA 487/LIDA 489/LIDA 287/LIDA 289/LIF 481/LIP 581 (incremental type)

POINT
<ul style="list-style-type: none"><li>● This linear encoder is of four-wire type. When using this linear encoder, change the parameter to select the four-wire type. For changing parameters, refer to each servo amplifier instruction manual.</li><li>● When using a linear encoder of four-wire type with fully closed loop control, use an MR-J4-(DU)_A_-RJ, MR-J4-(DU)_B_-RJ, or MR-J4-_GF_-RJ.</li><li>● When using a linear encoder of four-wire type with scale measurement function, use an MR-J4-(DU)_B_-RJ or MR-J4-_GF_-RJ.</li></ul>

# 1. LINEAR ENCODER

## (1) Cable composition

Prepare a cable based on the following configuration diagram.

### (a) For the linear servo motor

- 1) MR-J4- \_A\_ /MR-J4- \_B\_ /MR-J4- \_GF\_ /MR-J4W- \_B

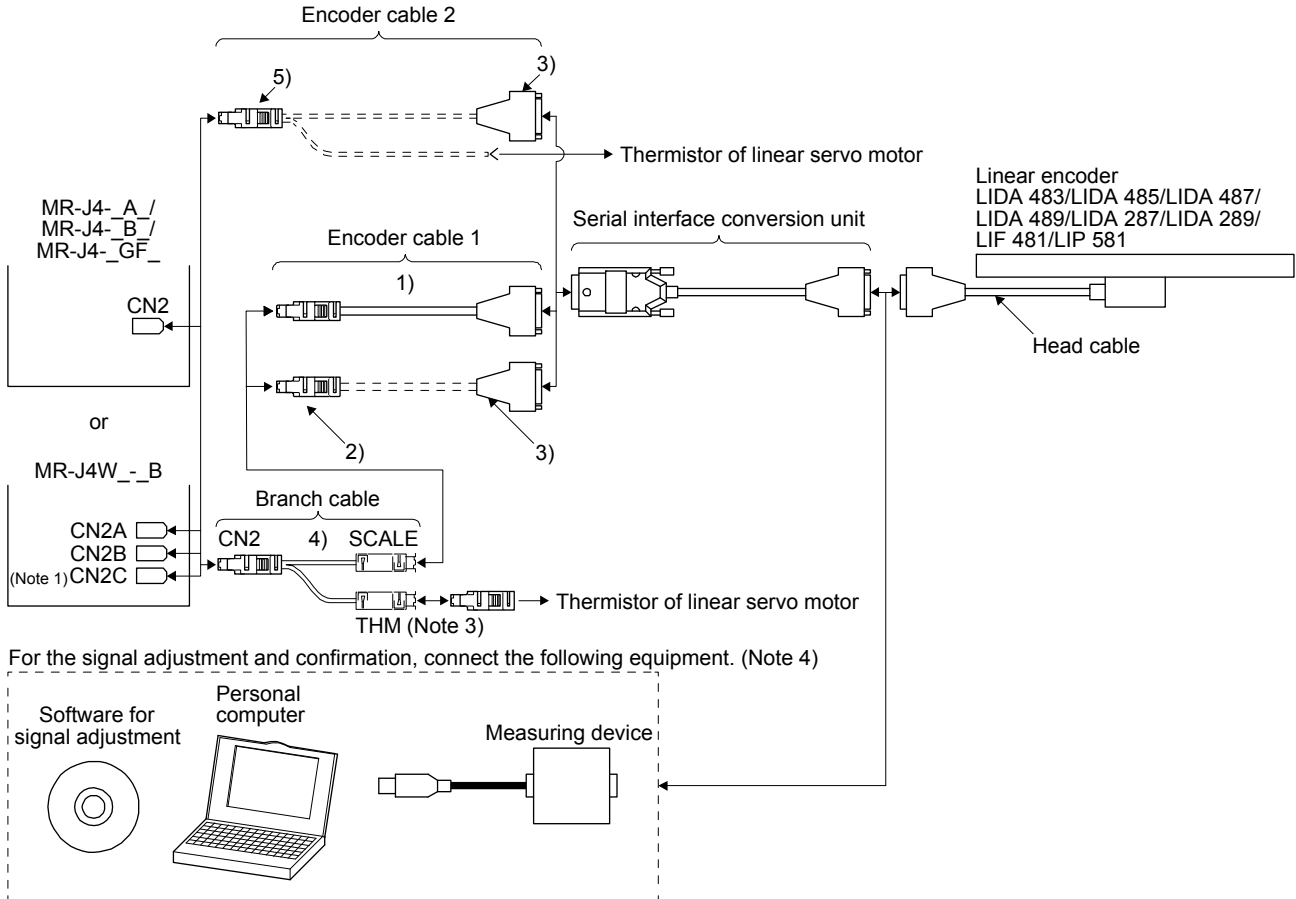

	Branch cable	Encoder cable	Serial interface conversion unit	Head cable
When using an optional encoder cable	4) MR-J4THCBL03M (Refer to section 2.4.)	1) Options manufactured by Heidenhain (Note 2) 630 856-xx _m	EIB 392M Cable length: 0.5 m (Heidenhain) (Note 2)	Accessories for linear encoder Cable length: 3 m
When fabricating the encoder cable		2) Connector set MR-J3CN2 (Refer to (2) (a) in this section.)		
When not using a branch cable		5) Connector set MR-J3CN2 (Refer to (2) (b) in this section.)		
			3) Junction connector (Note 2) D-SUB15 pin (female)	

- Note 1. The connection to CN2C is for the MR-J4 3-axis servo amplifier. MR-J4 2-axis servo amplifier does not have CN2C.
2. It should be prepared by the customer.
3. For connectors for thermistor signals, change how to connect depending on the customer's system.
4. When you mount LIDA 483, LIDA 485, LIDA 487, LIDA 489, LIDA 287, or LIDA 289, a personal computer (with a USB port) for the signal adjustment and confirmation, and a software and measuring device for signal adjustment are required. For details, contact Heidenhain.

# 1. LINEAR ENCODER

## 2) MR-J4-\_A\_-RJ/MR-J4-\_B\_-RJ/MR-J4-\_GF\_-RJ

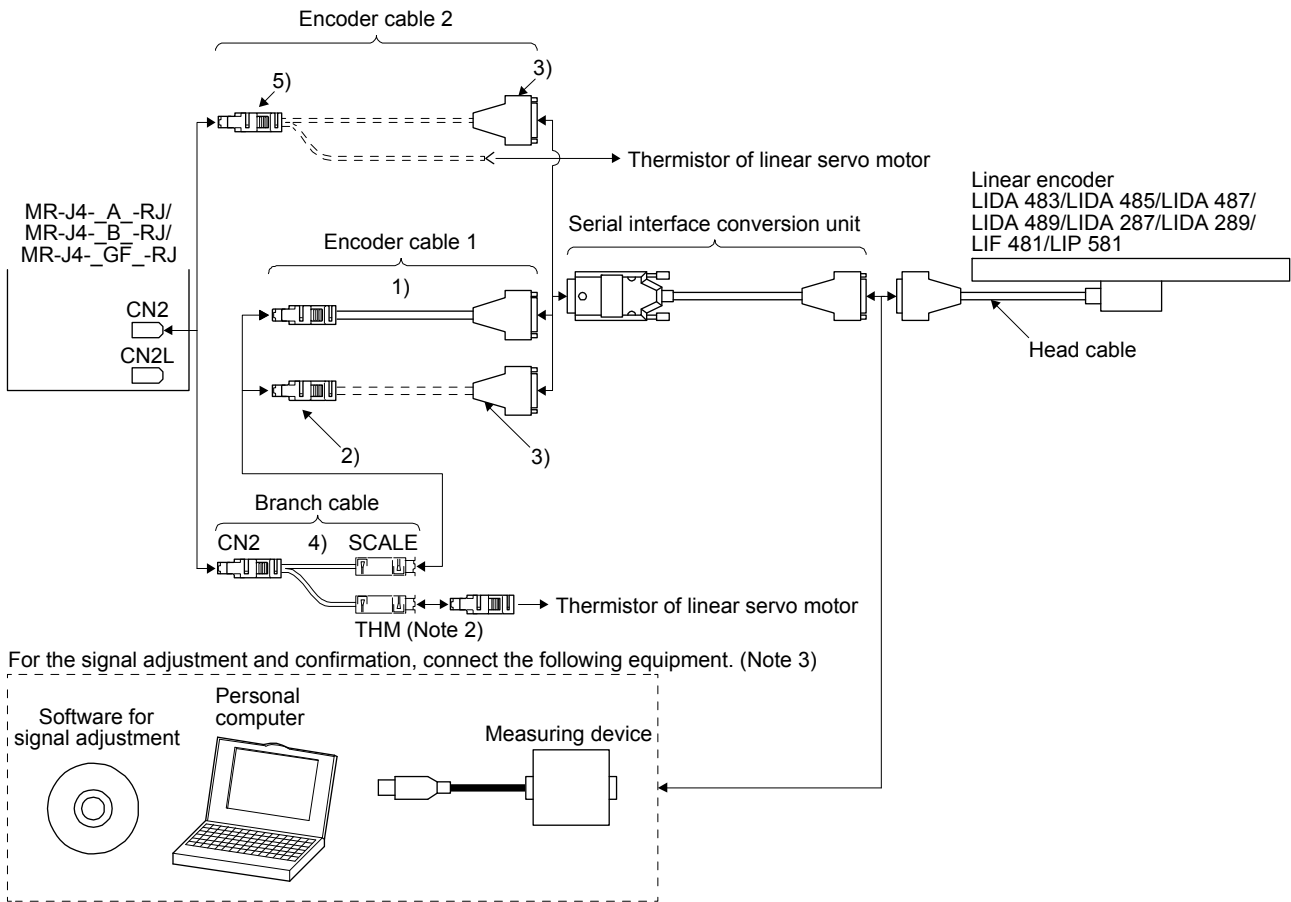

	Branch cable	Encoder cable	Serial interface conversion unit	Head cable
When using an optional encoder cable	4) MR-J4THCBL03M (Refer to section 2.4.)	1) Options manufactured by Heidenhain (Note 1) 630 856-xx _m	EIB 392M Cable length: 0.5 m (Heidenhain) (Note 1)	Accessories for linear encoder Cable length: 3 m
When fabricating the encoder cable		2) Connector set MR-J3CN2 (Refer to (2) (a) in this section.)		
When not using a branch cable		5) Connector set MR-J3CN2 (Refer to (2) (b) in this section.)		

Note 1. It should be prepared by the customer.

Note 2. For connectors for thermistor signals, change how to connect depending on the customer's system.

Note 3. When you mount LIDA 483, LIDA 485, LIDA 487, LIDA 489, LIDA 287, or LIDA 289, a personal computer (with a USB port) for the signal adjustment and confirmation, and a software and measuring device for signal adjustment are required. For details, contact Heidenhain.

# 1. LINEAR ENCODER

(b) When using for fully closed loop system and scale measurement function  
 MR-J4-(DU)\_A\_-RJ/MR-J4-(DU)\_B\_-RJ/MR-J4-\_GF\_-RJ

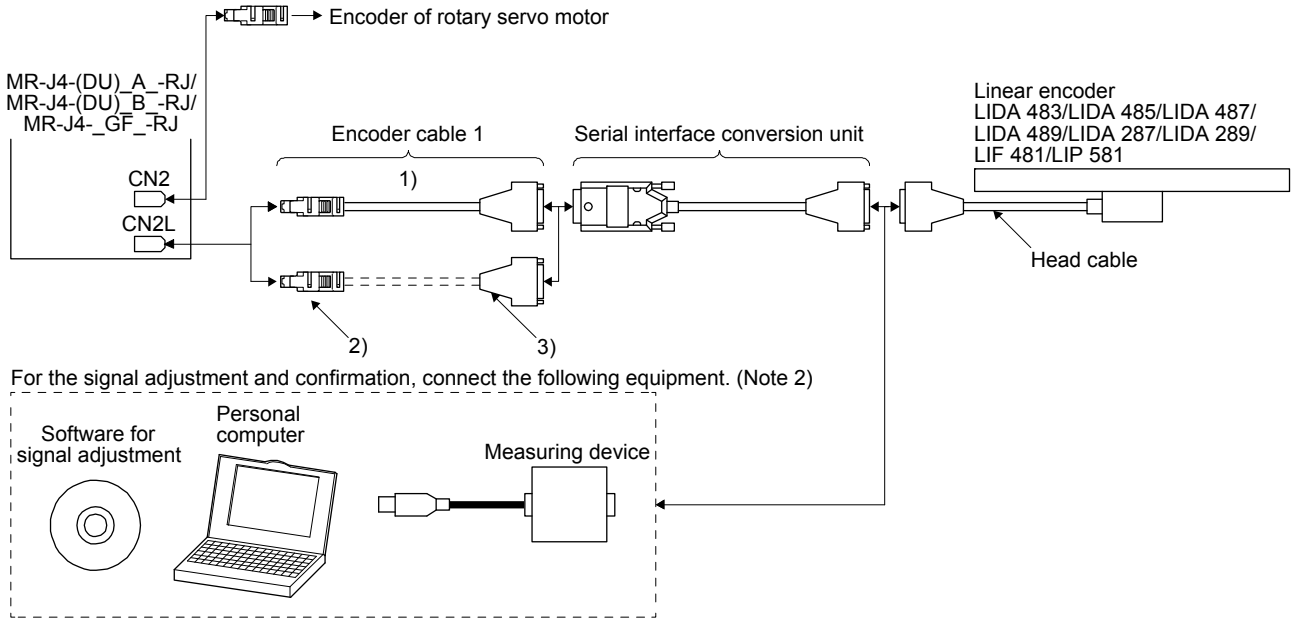

	Encoder cable		Serial interface conversion unit	Head cable
When using an optional encoder cable	1) Options manufactured by Heidenhain (Note 1) 630 856-xx _m		EIB 392M Cable length: 0.5 m (Heidenhain)	Accessories for linear encoder Cable length: 3 m
When fabricating the encoder cable	2) Connector set MR-J3CN2 (Refer to (2) (a) in this section.)	3) Junction connector (Note 1) D-SUB15 pin (female)	(Note)	

Note 1. It should be prepared by the customer.

2. When you mount LIDA 483, LIDA 485, LIDA 487, LIDA 489, LIDA 287, or LIDA 289, a personal computer (with a USB port) for the signal adjustment and confirmation, and a software and measuring device for signal adjustment are required. For details, contact Heidenhain.

# 1. LINEAR ENCODER

## (2) Production of encoder cable

Produce the encoder cable using MR-J3CN2 or a junction connector as shown below. The encoder cable can be produced as the length of maximum 30 m.

### (a) Encoder cable 1

Connector set (option)  
MR-J3CN2  
Receptacle: 36210-0100PL  
Shell kit: 36310-3200-008  
(3M) (Note 2)

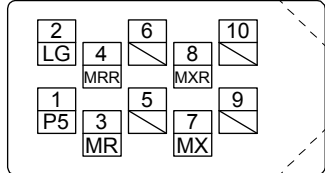

View seen from wiring side. (Note 3)

or

Connector set: 54599-1019  
(Molex) (Note 2)

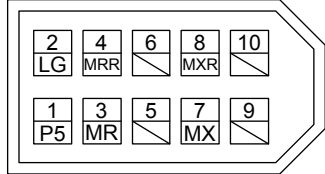

View seen from wiring side. (Note 3)

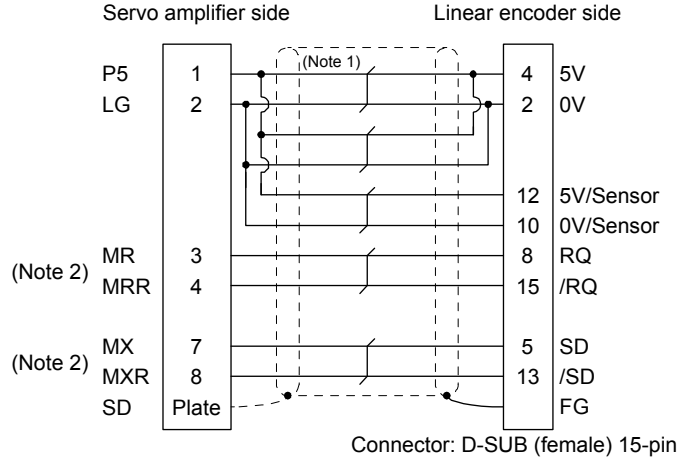

Note 1. We recommend the following specifications encoder cables.

Wiring length	Number of LG and P5 connections	Cable size
to 5 m	1-pair	AWG 22
to 10 m	2-pair	
to 20 m	3-pair	
to 30 m	4-pair	

2. For the CN2L connector, signals of pin 3, pin 4, pin 7, and pin 8 will be as follows.

Pin 3: MR2 Pin 4: MRR2 Pin 7: MX2 Pin 8: MXR2

3. Do not connect anything to the pins shown as . Especially, pin 10 is for manufacturer adjustment. If it is connected with any other pin, the servo amplifier cannot operate normally. Referring to POINT of chapter 1, securely connect the external conductor of the shielded cable to the ground plate and fix it to the connector shell.

# 1. LINEAR ENCODER

## (b) Encoder cable 2

Connector set (option)  
MR-J3CN2  
Receptacle: 36210-0100PL  
Shell kit: 36310-3200-008  
(3M)

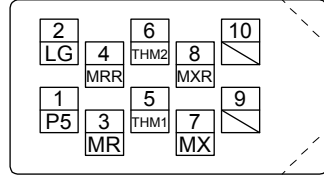

View seen from wiring side. (Note 3)

or

Connector set: 54599-1019  
(Molex)

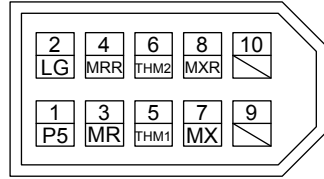

View seen from wiring side. (Note 3)

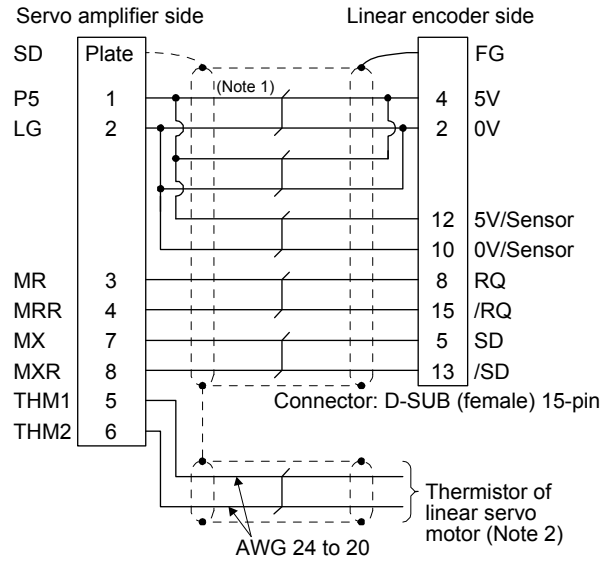

Note 1. We recommend the following specifications encoder cables.

Wiring length	Number of LG and P5 connections	Cable size
to 5 m	1-pair	AWG 22
to 10 m	2-pair	
to 20 m	3-pair	
to 30 m	4-pair	

- For wiring to the thermistor of the linear servo motor, refer to "Linear Servo Motor Instruction Manual".
- Do not connect anything to the pins shown as . Especially, pin 10 is for manufacturer adjustment. If it is connected with any other pin, the servo amplifier cannot operate normally. Referring to POINT of chapter 1, securely connect the external conductor of the shielded cable to the ground plate and fix it to the connector shell.

# 1. LINEAR ENCODER

## 1.4 Linear encoder manufactured by Magescale

POINT
<ul style="list-style-type: none"> <li>● SR27A, SR67A, SR77, and SR87 are absolute type. SR75 and SR85 are incremental position type.</li> <li>● When the absolute position detection system is configured, the absolute position battery is not required.</li> </ul>

### 1.4.1 SR77/SR87/SR75/SR85

#### (1) Cable composition

Prepare a cable based on the following configuration diagram.

##### (a) For the linear servo motor

##### 1) MR-J4- \_A\_ /MR-J4- \_B\_ /MR-J4- \_GF\_ /MR-J4W- \_B

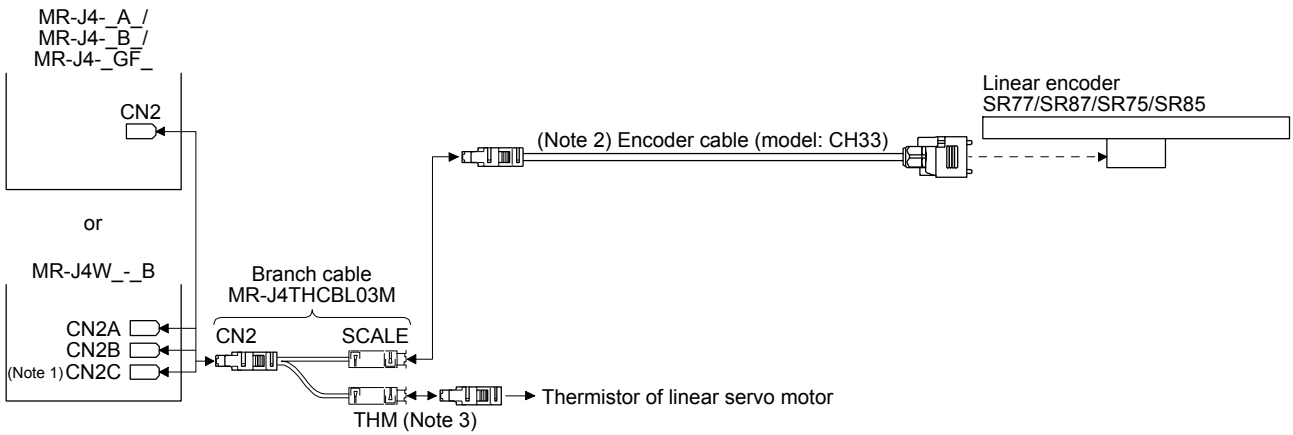

- Note 1. The connection to CN2C is for the MR-J4 3-axis servo amplifier. MR-J4 2-axis servo amplifier does not have CN2C.  
 Note 2. This option is manufactured by Magescale. It should be prepared by the customer.  
 Note 3. For connectors for thermistor signals, change how to connect depending on the customer's system.

##### 2) MR-J4- \_A\_ -RJ/MR-J4- \_B\_ -RJ/MR-J4- \_GF\_ -RJ

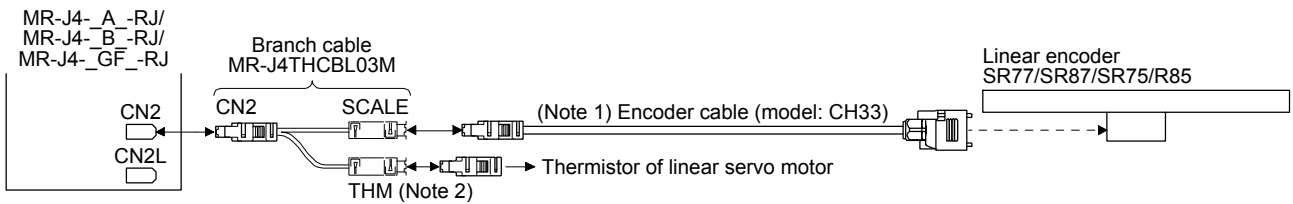

- Note 1. This option is manufactured by Magescale. It should be prepared by the customer.  
 Note 2. For connectors for thermistor signals, change how to connect depending on the customer's system.

# 1. LINEAR ENCODER

(b) For the fully closed loop system and scale measurement function

1) MR-J4-(DU)\_A\_/MR-J4-(DU)\_B\_/MR-J4-\_GF\_/MR-J4W2-\_B

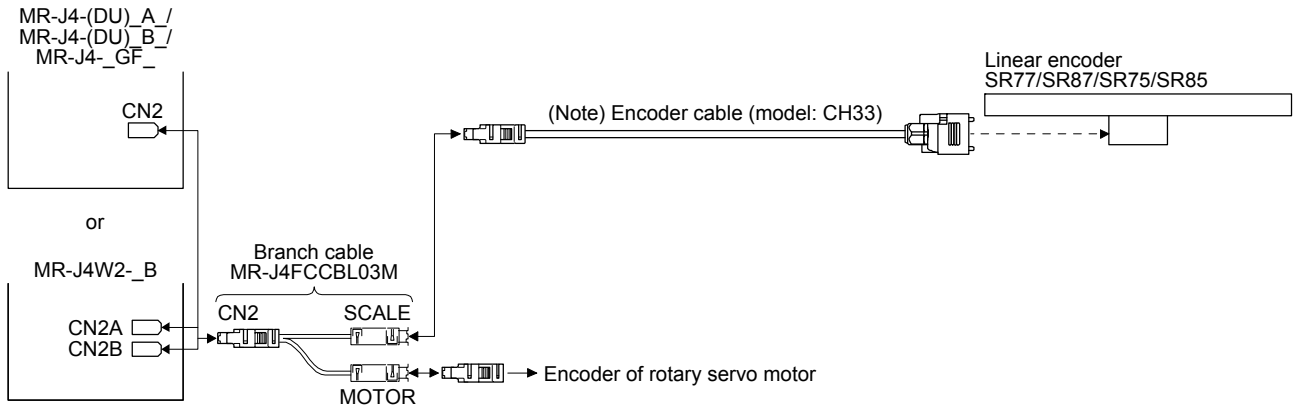

Note. This option is manufactured by Magnescale. It should be prepared by the customer.

2) MR-J4-(DU)\_A\_-RJ/MR-J4-(DU)\_B\_-RJ/MR-J4-\_GF\_-RJ

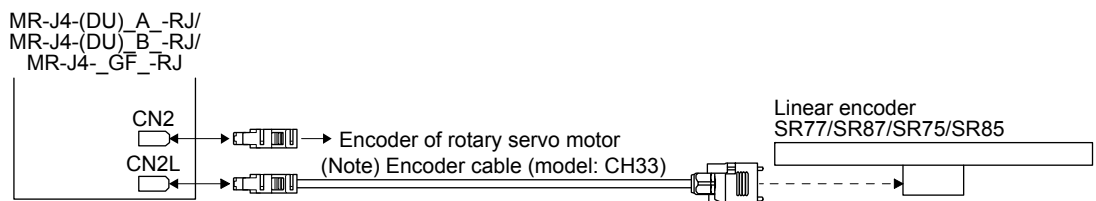

Note. This option is manufactured by Magnescale. It should be prepared by the customer.

# 1. LINEAR ENCODER

## 1.4.2 SL710 + PL101-RM/RHM (incremental type)

### (1) Cable composition

Prepare a cable based on the following configuration diagram.

#### (a) For the linear servo motor

- 1) MR-J4-\_A\_/MR-J4-\_B\_/MR-J4-\_GF\_/MR-J4W\_-\_B

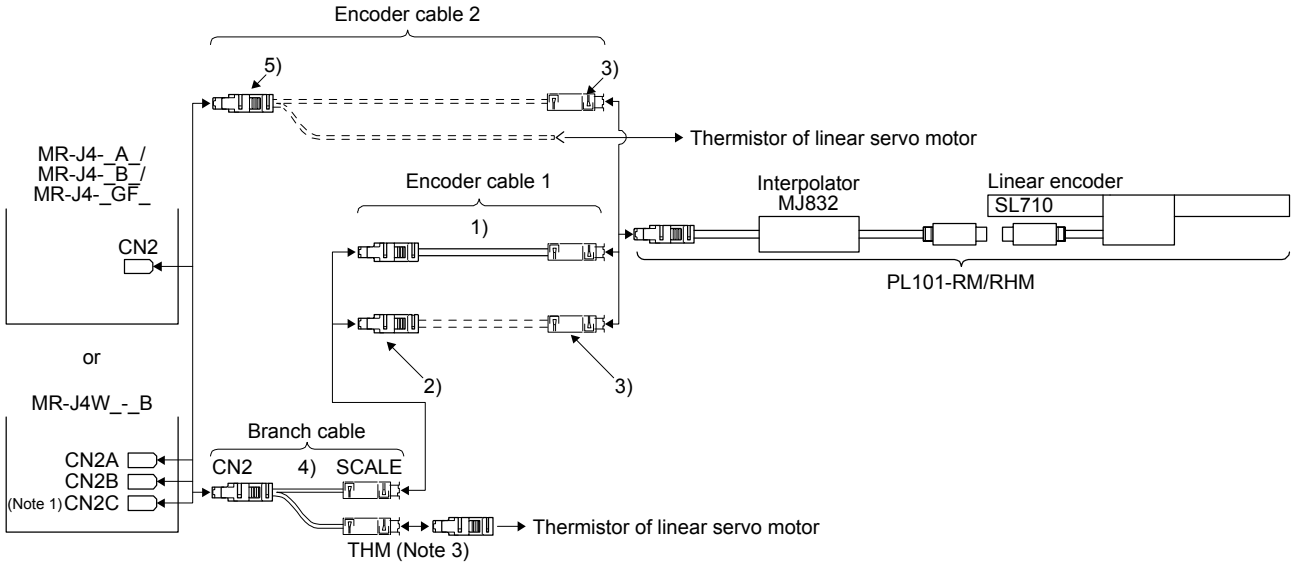

	Branch cable	Encoder cable	Interpolator
When using an optional encoder cable	4) MR-J4THCBL03M (Refer to section 2.4.)	1) Options manufactured by Magnescale (Note 2) CE33_	Accessories for linear encoder MJ832
When fabricating the encoder cable		2) Connector set MR-J3CN2 (Refer to (2) (a) of this section.)	
When not using a branch cable		5) Connector set MR-J3CN2 (Refer to (2) (b) of this section.)	

Note 1. The connection to CN2C is for the MR-J4 3-axis servo amplifier. MR-J4 2-axis servo amplifier does not have CN2C.

2. It should be prepared by the customer.

3. For connectors for thermistor signals, change how to connect depending on the customer's system.

# 1. LINEAR ENCODER

## 2) MR-J4- \_A\_-RJ/MR-J4- \_B\_-RJ/MR-J4- \_GF\_-RJ

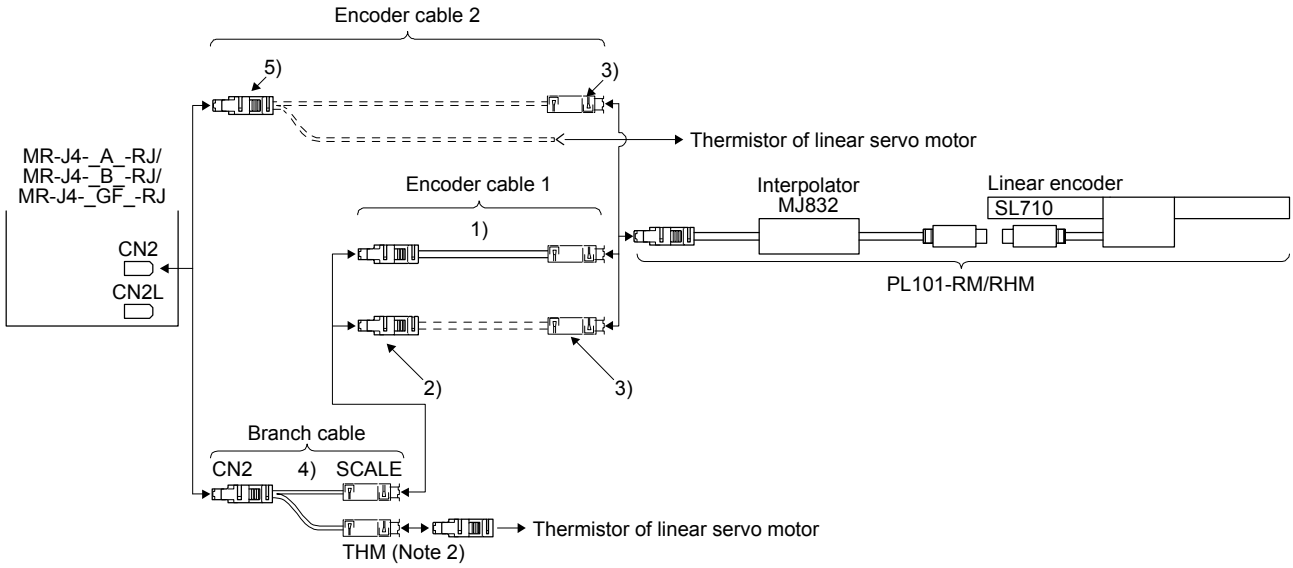

	Branch cable	Encoder cable		Interpolator
When using an optional encoder cable	4) MR-J4THCBL03M (Refer to section 2.4.)	1) Options manufactured by Magnescale (Note 1) CE33- _		Accessories for linear encoder MJ832
When fabricating the encoder cable		2) Connector set MR-J3CN2 (Refer to (2) (a) of this section.)	3) Junction connector (Note 1) Plug: 36110-3000FD Shell kit: 36310-F200-008 (3M or equivalent)	
When not using a branch cable		5) Connector set MR-J3CN2 (Refer to (2) (b) of this section.)		

Note 1. It should be prepared by the customer.

2. For connectors for thermistor signals, change how to connect depending on the customer's system.

# 1. LINEAR ENCODER

(b) For the fully closed loop system and scale measurement function

1) MR-J4-(DU)\_A\_/MR-J4-(DU)\_B\_/MR-J4-\_GF\_/MR-J4W2-\_B

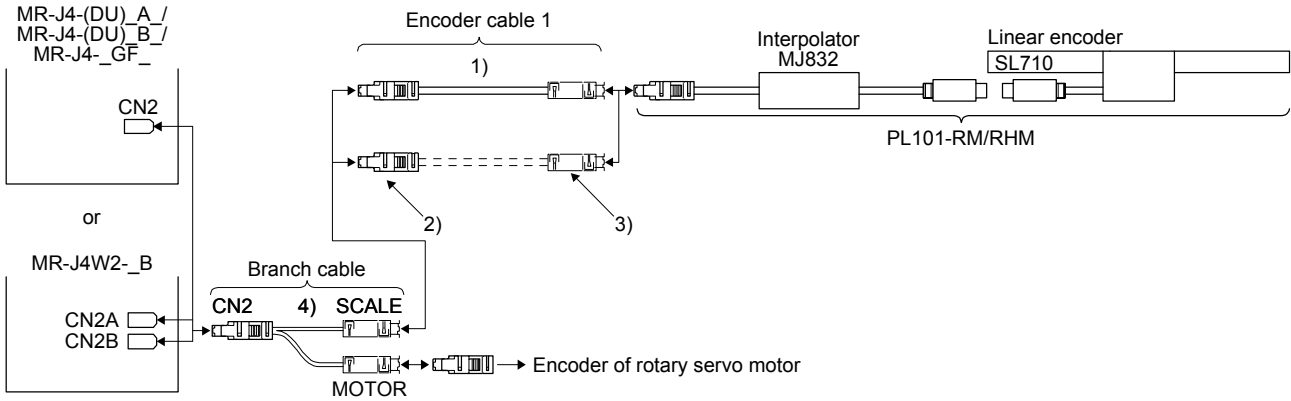

	Branch cable	Encoder cable		Interpolator
When using an optional encoder cable	4) MR-J4FCCBL03M (Refer to section 2.5.)	1) Options manufactured by Magnescale (Note) CE33_		Accessories for linear encoder MJ832
When fabricating the encoder cable		2) Connector set MR-J3CN2 (Refer to (2) (a) of this section.)	3) Junction connector (Note) Plug: 36110-3000FD Shell kit: 36310-F200-008 (3M or equivalent)	

Note. It should be prepared by the customer.

2) MR-J4-(DU)\_A\_-RJ/MR-J4-(DU)\_B\_-RJ/MR-J4-\_GF\_-RJ

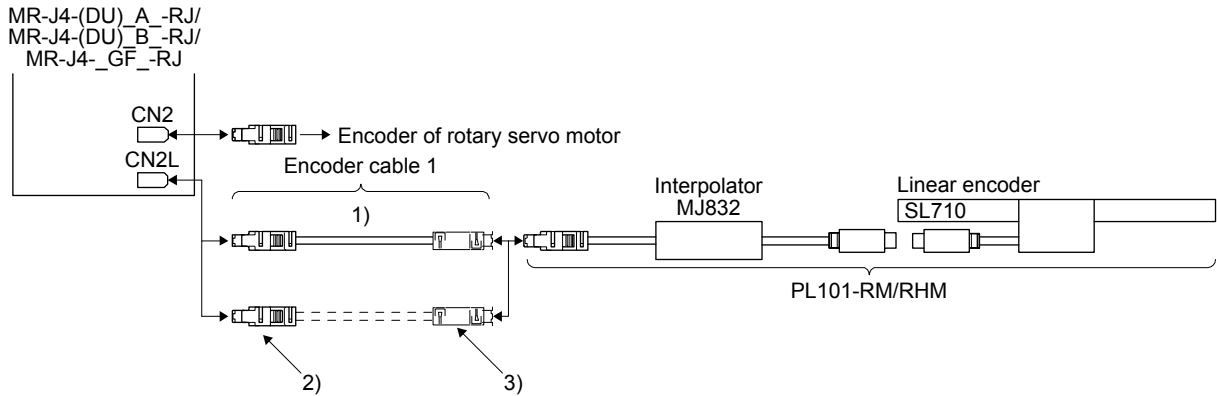

	Encoder cable		Interpolator
When using an optional encoder cable	1) Options manufactured by Magnescale (Note) CE33_		Accessories for linear encoder MJ832
When fabricating the encoder cable	2) Connector set MR-J3CN2 (Refer to (2) (a) of this section.)	3) Junction connector (Note) Plug: 36110-3000FD Shell kit: 36310-F200-008 (3M or equivalent)	

Note. It should be prepared by the customer.

# 1. LINEAR ENCODER

## (2) Production of encoder cable between the servo amplifier and the interpolator

Produce the encoder cable using MR-J3CN2 or a junction connector as shown below. The encoder cable can be produced as the length of maximum 30 m.

### (a) Encoder cable 1

Connector set (option)  
MR-J3CN2  
Receptacle: 36210-0100PL  
Shell kit: 36310-3200-008  
(3M) (Note 2)

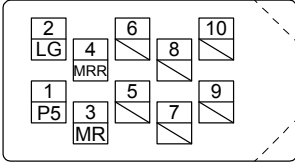

View seen from wiring side. (Note 3)

or

Connector set: 54599-1019  
(Molex) (Note 2)

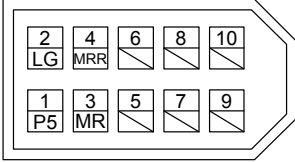

View seen from wiring side. (Note 3)

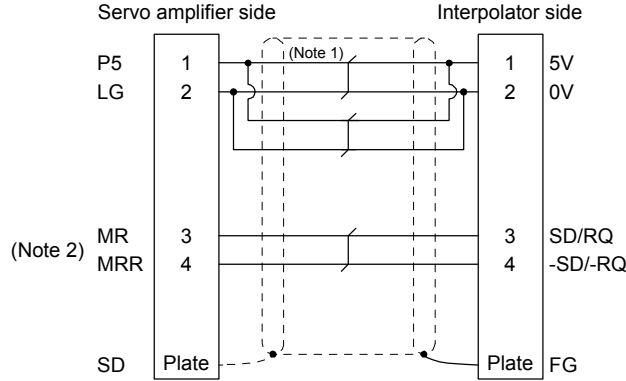

Plug: 36110-3000FD  
Shell kit: 36310-F200-008  
(3M or equivalent)

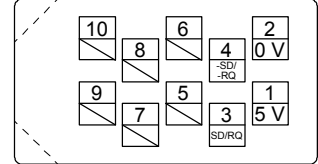

View seen from wiring side.

Note 1. We recommend the following specifications encoder cables.

Wiring length	Number of LG and P5 connections	Cable size
to 5 m	1-pair	AWG 22
to 10 m	2-pair	
to 20 m	3-pair	
to 30 m	4-pair	

2. For the CN2L connector, signals of pin 3 and pin 4 will be as follows.

Pin 3: MR2 Pin 4: MRR2

3. Do not connect anything to the pins shown as . Especially, pin 10 is for manufacturer adjustment. If it is connected with any other pin, the servo amplifier cannot operate normally. Referring to POINT of chapter 1, securely connect the external conductor of the shielded cable to the ground plate and fix it to the connector shell.

# 1. LINEAR ENCODER

## (b) Encoder cable 2

Connector set (option)  
MR-J3CN2  
Receptacle: 36210-0100PL  
Shell kit: 36310-3200-008  
(3M)

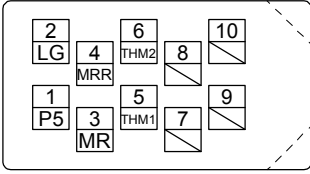

View seen from wiring side. (Note 3)

or

Connector set: 54599-1019  
(Molex)

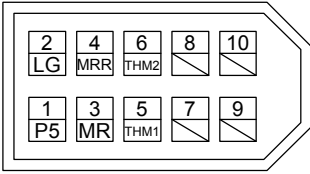

View seen from wiring side. (Note 3)

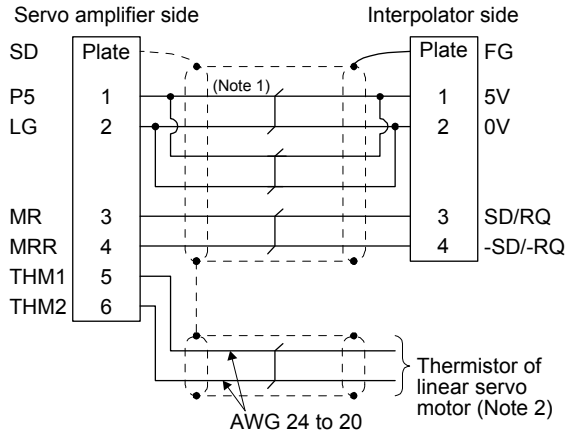

Plug: 36110-3000FD  
Shell kit: 36310-F200-008  
(3M or equivalent)

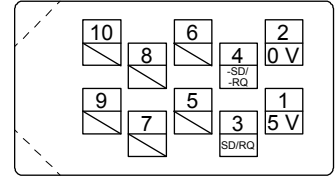

View seen from wiring side.

Note 1. We recommend the following specifications encoder cables.

Wiring length	Number of LG and P5 connections	Cable size
to 5 m	1-pair	AWG 22
to 10 m	2-pair	
to 20 m	3-pair	
to 30 m	4-pair	

- For wiring to the thermistor of the linear servo motor, refer to "Linear Servo Motor Instruction Manual".
- Do not connect anything to the pins shown as . Especially, pin 10 is for manufacturer adjustment. If it is connected with any other pin, the servo amplifier cannot operate normally. Referring to POINT of chapter 1, securely connect the external conductor of the shielded cable to the ground plate and fix it to the connector shell.

# 1. LINEAR ENCODER

## 1.4.3 SR27A/SR67A

### (1) Cable structure

Prepare a cable based on the following configuration diagram.

#### (a) For the linear servo motor

##### 1) MR-J4- \_A\_ /MR-J4- \_B\_ /MR-J4- \_GF\_ /MR-J4W- \_ \_B

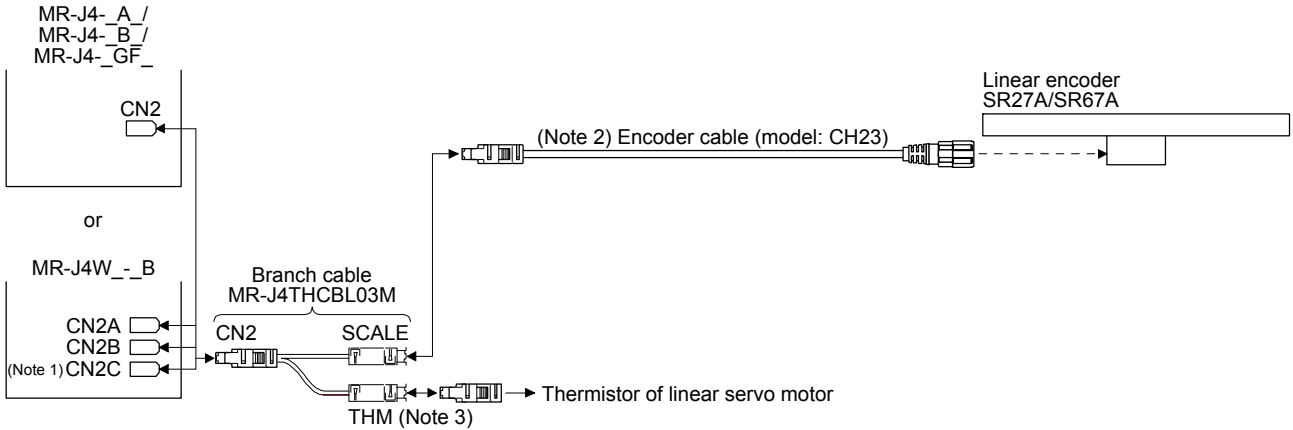

Note 1. The connection to CN2C is for the MR-J4 3-axis servo amplifier. MR-J4 2-axis servo amplifier does not have CN2C.

Note 2. This option is manufactured by Magnescale. It should be prepared by the customer.

Note 3. For connectors for thermistor signals, change how to connect depending on the customer's system.

##### 2) MR-J4- \_A\_ -RJ/MR-J4- \_B\_ -RJ/MR-J4- \_GF\_ -RJ

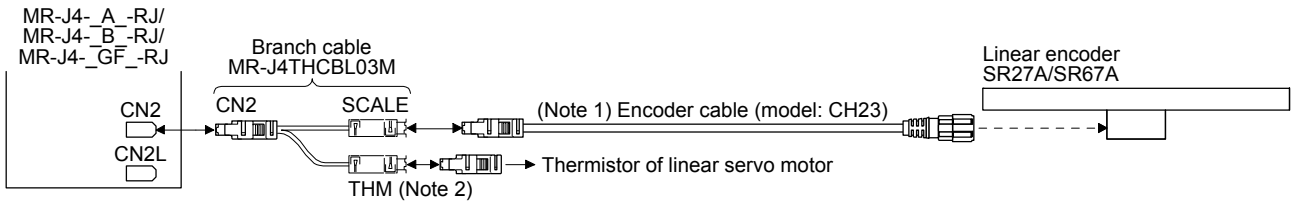

Note 1. This option is manufactured by Magnescale. It should be prepared by the customer.

Note 2. For connectors for thermistor signals, change how to connect depending on the customer's system.

# 1. LINEAR ENCODER

(b) When using for fully closed loop system and scale measurement function

1) MR-J4-(DU)\_A\_/MR-J4-(DU)\_B\_/MR-J4-\_GF\_/MR-J4W2-\_B

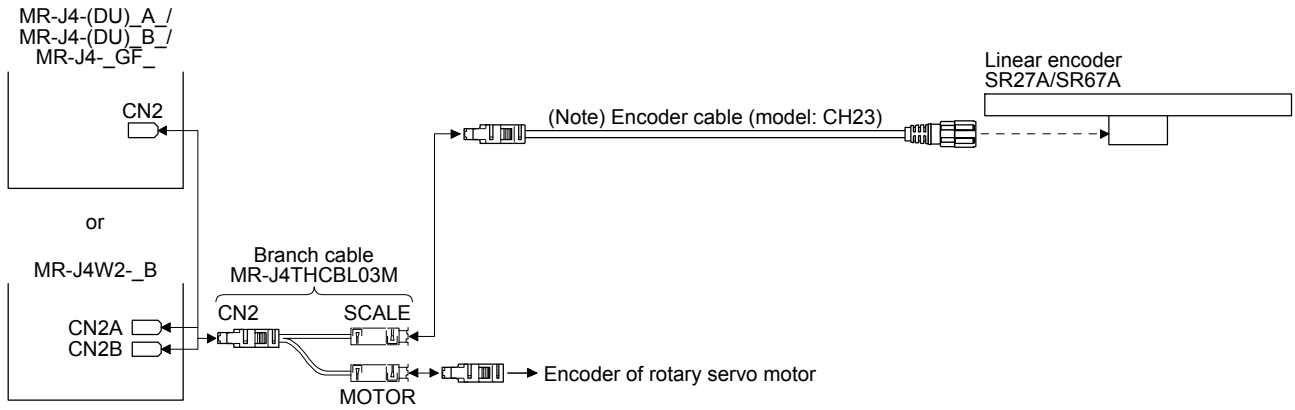

Note. This option is manufactured by Magnescale. It should be prepared by the customer.

2) MR-J4-(DU)\_A\_-RJ/MR-J4-(DU)\_B\_-RJ/MR-J4-\_GF\_-RJ

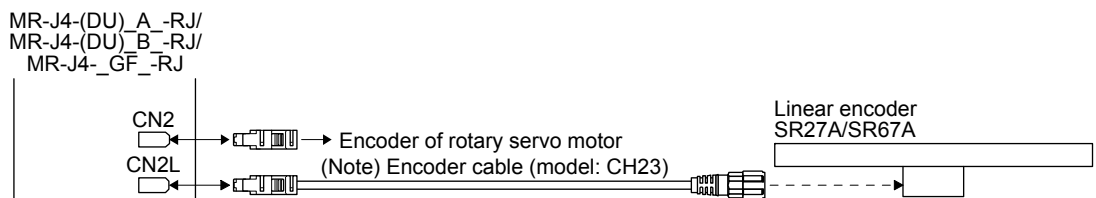

Note. This option is manufactured by Magnescale. It should be prepared by the customer.

# 1. LINEAR ENCODER

## 1.4.4 SQ10 + PQ10 + MQ10 (incremental type)

### (1) Cable structure

Prepare a cable based on the following configuration diagram.

#### (a) For the linear servo motor

- 1) MR-J4-\_A\_/MR-J4-\_B\_/MR-J4-\_GF\_/MR-J4W\_-\_B

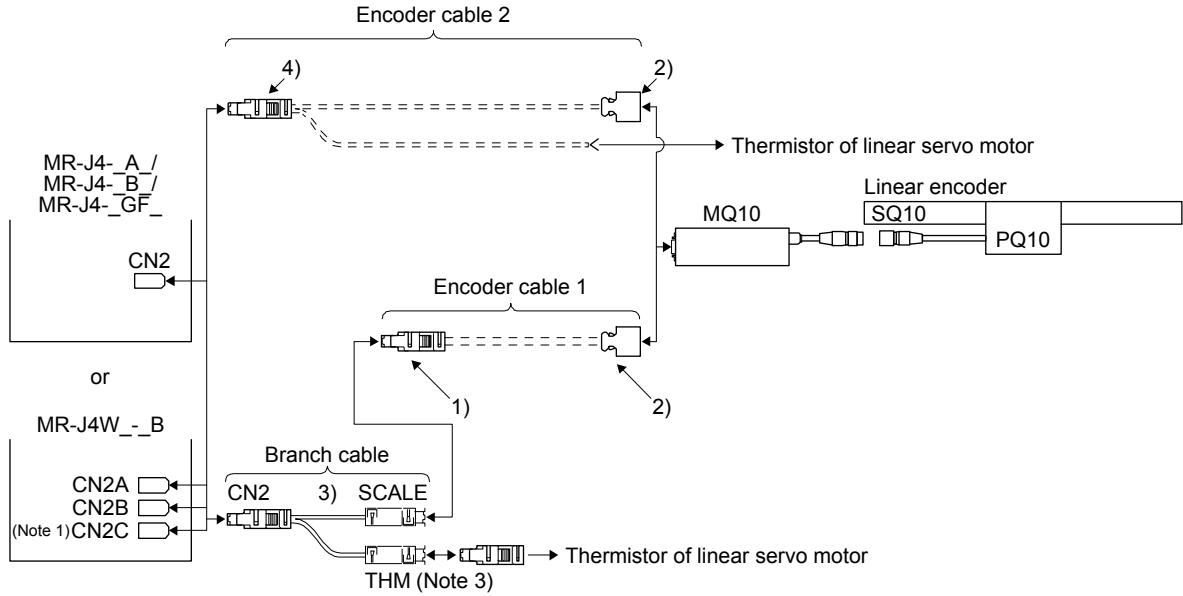

	Branch cable	Encoder cable	
When fabricating the encoder cable	3) MR-J4THCBL03M (Refer to section 2.4.)	1) Connector set MR-J3CN2 (Refer to (2) (a) of this section.)	2) Junction connector (Note 2) Plug: 10114-3000PE (3M) Shell kit: 10314-52F0-008 (3M)
When not using a branch cable		4) Connector set MR-J3CN2 (Refer to (2) (b) of this section.)	

- Note
1. The connection to CN2C is for the MR-J4 3-axis servo amplifier. MR-J4 2-axis servo amplifier does not have CN2C.
  2. It should be prepared by the customer.
  3. For connectors for thermistor signals, change how to connect depending on the customer's system.

# 1. LINEAR ENCODER

## 2) MR-J4-\_A\_-RJ/MR-J4-\_B\_-RJ/MR-J4-\_GF\_-RJ

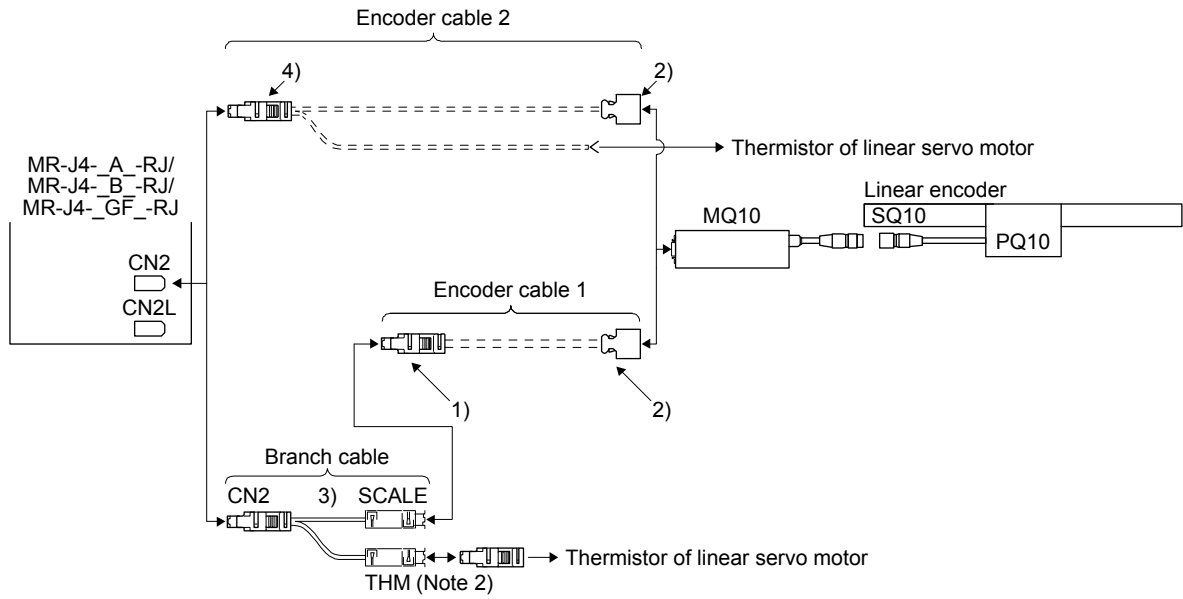

	Branch cable	Encoder cable	
When fabricating the encoder cable	3) MR-J4THCBL03M (Refer to section 2.4.)	1) Connector set MR-J3CN2 (Refer to (2) (a) of this section.)	2) Junction connector (Note 1) Plug: 10114-3000PE (3M) Shell kit: 10314-52F0-008 (3M)
When not using a branch cable		4) Connector set MR-J3CN2 (Refer to (2) (b) of this section.)	

Note 1. It should be prepared by the customer.

2. For connectors for thermistor signals, change how to connect depending on the customer's system.

# 1. LINEAR ENCODER

(b) When using for fully closed loop system and scale measurement function

1) MR-J4-(DU)\_A\_/MR-J4-(DU)\_B\_/MR-J4-\_GF\_/MR-J4W2-\_B

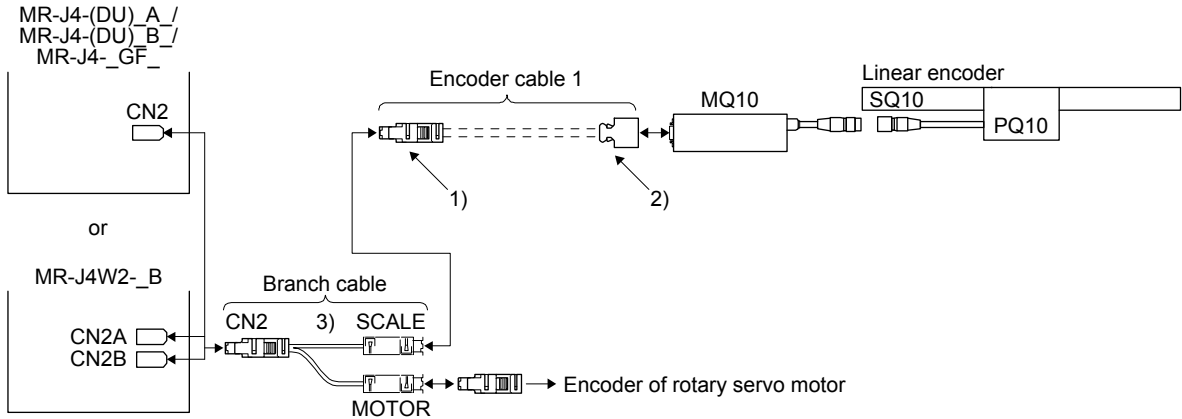

	Branch cable	Encoder cable	
When fabricating the encoder cable	3) MR-J4FCCBL03M (Refer to section 2.5.)	1) Connector set MR-J3CN2 (Refer to (2) (a) of this section.)	2) Junction connector (Note) Plug: 10114-3000PE (3M) Shell kit: 10314-52F0-008 (3M)

Note. It should be prepared by the customer.

2) MR-J4-(DU)\_A\_-RJ/MR-J4-(DU)\_B\_-RJ/MR-J4-\_GF\_-RJ

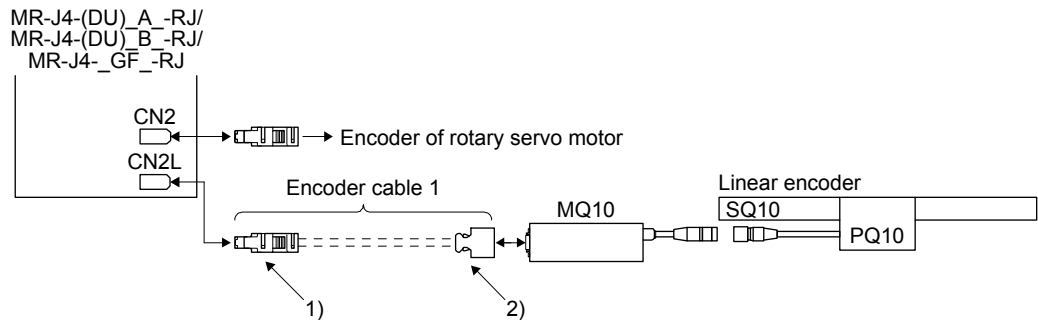

	Encoder cable	
When fabricating the encoder cable	1) Connector set MR-J3CN2 (Refer to (2) (a) of this section.)	2) Junction connector (Note) Plug: 10114-3000PE (3M) Shell kit: 10314-52F0-008 (3M)

Note. It should be prepared by the customer.

# 1. LINEAR ENCODER

(2) Production of encoder cable between the servo amplifier and the interpolator  
 Produce the encoder cable using MR-J3CN2 or a junction connector as shown below. The encoder cable can be produced as the length of maximum 30 m.

## (a) Encoder cable 1

Connector set (option)  
 MR-J3CN2  
 Receptacle: 36210-0100PL  
 Shell kit: 36310-3200-008  
 (3M) (Note 2)

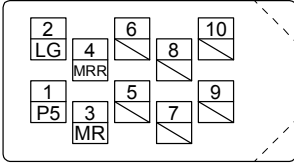

View seen from wiring side. (Note 3)

or

Connector set: 54599-1019  
 (Molex) (Note 2)

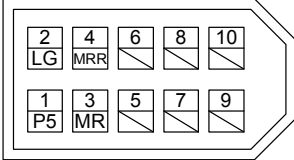

View seen from wiring side. (Note 3)

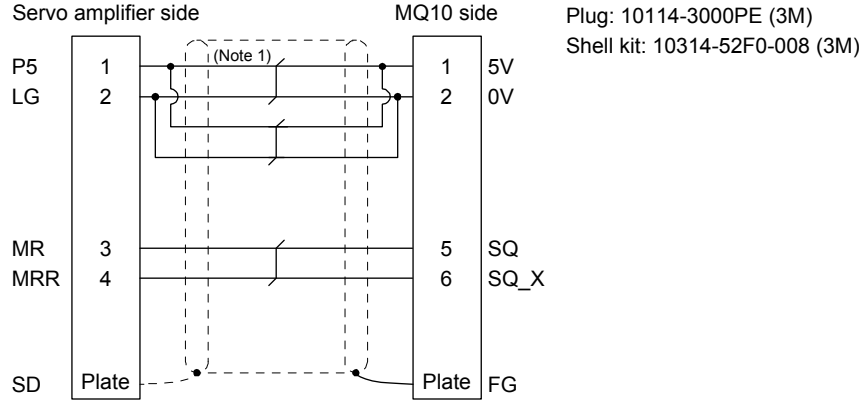

Plug: 10114-3000PE (3M)  
 Shell kit: 10314-52F0-008 (3M)

Note 1. We recommend the following specifications encoder cables.

Wiring length	Number of LG and P5 connections	Cable size
to 5 m	1-pair	AWG 22
to 10 m	2-pair	
to 20 m	3-pair	
to 30 m	4-pair	

2. For the CN2L connector, signals of pin 3 and pin 4 will be as follows.

Pin 3: MR2 Pin 4: MRR2

3. Do not connect anything to the pins shown as . Especially, pin 10 is for manufacturer adjustment. If it is connected with any other pin, the servo amplifier cannot operate normally. Referring to POINT of chapter 1, securely connect the external conductor of the shielded cable to the ground plate and fix it to the connector shell.

# 1. LINEAR ENCODER

## (b) Encoder cable 2

Connector set (option)  
 MR-J3CN2  
 Receptacle: 36210-0100PL  
 Shell kit: 36310-3200-008  
 (3M)

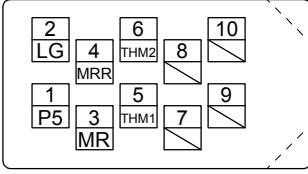

View seen from wiring side. (Note 3)

or

Connector set: 54599-1019  
 (Molex)

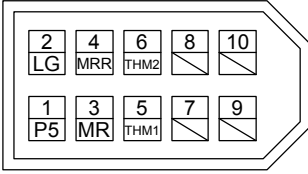

View seen from wiring side. (Note 3)

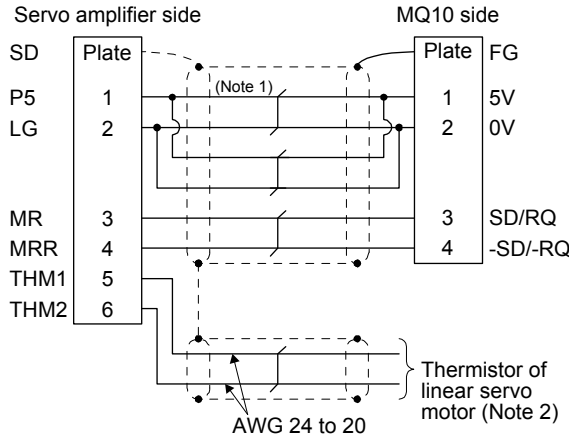

Plug: 10114-3000PE (3M)  
 Shell kit: 10314-52F0-008 (3M)

Note 1. We recommend the following specifications encoder cables.

Wiring length	Number of LG and P5 connections	Cable size
to 5 m	1-pair	AWG 22
to 10 m	2-pair	
to 20 m	3-pair	
to 30 m	4-pair	

- For wiring to the thermistor of the linear servo motor, refer to "Linear Servo Motor Instruction Manual".
- Do not connect anything to the pins shown as . Especially, pin 10 is for manufacturer adjustment. If it is connected with any other pin, the servo amplifier cannot operate normally. Referring to POINT of chapter 1, securely connect the external conductor of the shielded cable to the ground plate and fix it to the connector shell.

# 1. LINEAR ENCODER

## 1.5 Linear encoder manufactured by Renishaw

**POINT**

● When the absolute position detection system is configured, the absolute position battery is not required.

### 1.5.1 RESOLUTE RL40M (absolute position type)

#### (1) Cable composition

Prepare a cable based on the following configuration diagram.

#### (a) For the linear servo motor

- 1) MR-J4-\_A\_/MR-J4-\_B\_/MR-J4-\_GF\_/MR-J4W\_-\_B

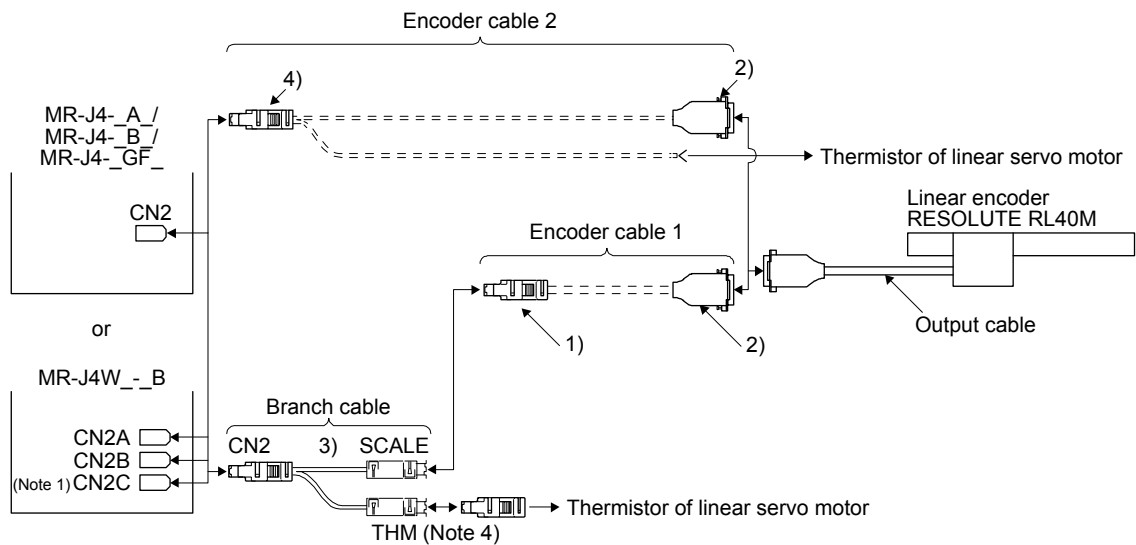

	Branch cable	Encoder cable (Note 2)		Output cable
When using a branch cable	3) MR-J4THCBL03M (Refer to section 2.4.)	1) Connector set MR-J3CN2 (Refer to (2) (a) of this section.)	2) Junction connector (Note 3) D-SUB15 pin (female)	Accessories for linear encoder Cable length: 0.5 m
When not using a branch cable		4) Connector set MR-J3CN2 (Refer to (2) (b) of this section.)		

- Note
1. The connection to CN2C is for the MR-J4 3-axis servo amplifier. MR-J4 2-axis servo amplifier does not have CN2C.
  2. Produce an encoder cable. An optional cable is not provided.
  3. It should be prepared by the customer.
  4. For connectors for thermistor signals, change how to connect depending on the customer's system.

# 1. LINEAR ENCODER

## 2) MR-J4-\_A\_-RJ/MR-J4-\_B\_-RJ/MR-J4-\_GF\_-RJ

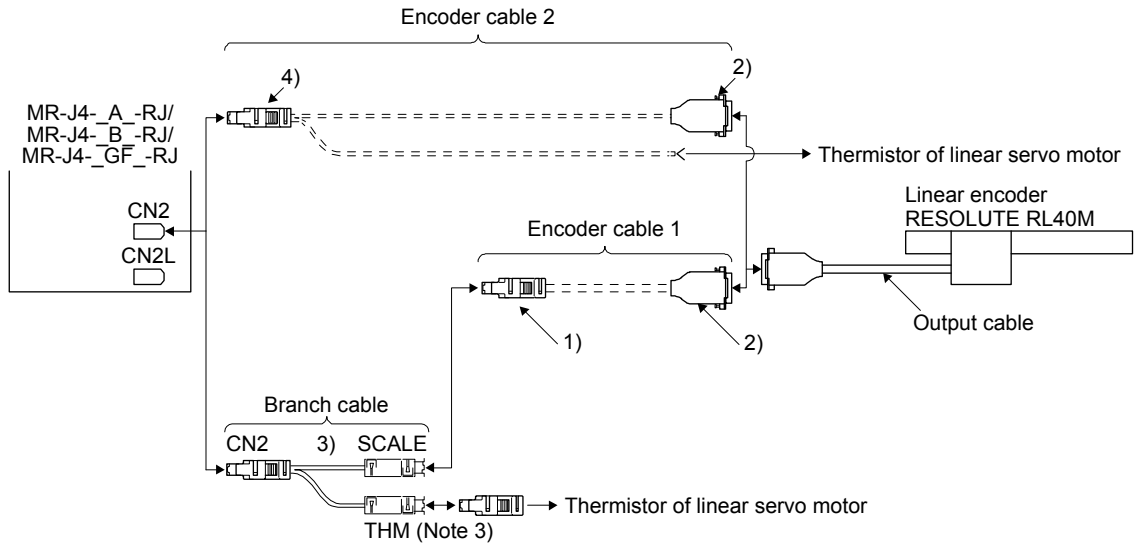

	Branch cable	Encoder cable (Note 1)		Output cable
When using a branch cable	3) MR-J4THCBL03M (Refer to section 2.4.)	1) Connector set MR-J3CN2 (Refer to (2) (a) of this section.)	2) Junction connector (Note 2) D-SUB15 pin (female)	Accessories for linear encoder Cable length: 0.5 m
When not using a branch cable		4) Connector set MR-J3CN2 (Refer to (2) (b) of this section.)		

- Note
1. Produce an encoder cable. An optional cable is not provided.
  2. It should be prepared by the customer.
  3. For connectors for thermistor signals, change how to connect depending on the customer's system.

# 1. LINEAR ENCODER

(b) For the fully closed loop system and scale measurement function

1) MR-J4-(DU)\_A\_/MR-J4-(DU)\_B\_/MR-J4-\_GF\_/MR-J4W2-\_B

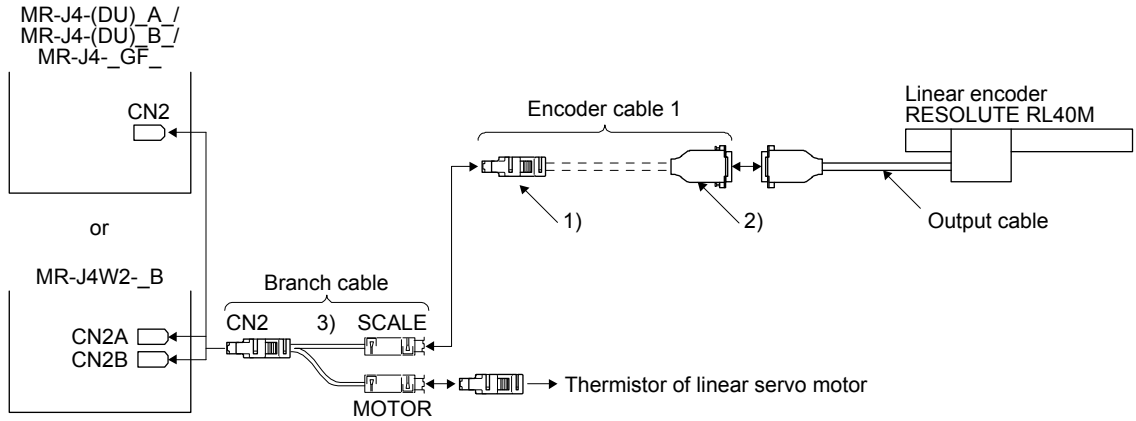

Branch cable	Encoder cable (Note 1)		Output cable
3) MR-J4FCCBL03M (Refer to section 2.5.)	1) Connector set MR-J3CN2 (Refer to (2) (a) of this section.)	2) Junction connector (Note 2) D-SUB15 pin (female)	Accessories for linear encoder Cable length: 0.5 m

Note 1. Produce an encoder cable. An optional cable is not provided.

2. It should be prepared by the customer.

2) MR-J4-(DU)\_A\_-RJ/MR-J4-(DU)\_B\_-RJ/MR-J4-\_GF\_-RJ

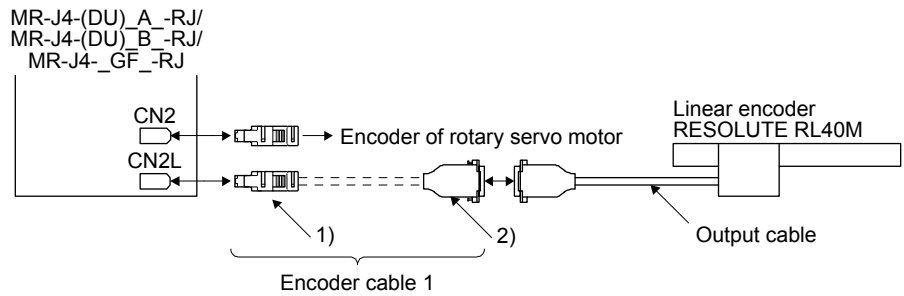

Encoder cable (Note 1)		Output cable
1) Connector set MR-J3CN2 (Refer to (2) (a) of this section.)	2) Junction connector (Note 2) D-SUB15 pin (female)	Accessories for linear encoder Cable length: 0.5 m

Note 1. Produce an encoder cable. An optional cable is not provided.

2. It should be prepared by the customer.

# 1. LINEAR ENCODER

## (2) Production of encoder cable

Produce the encoder cable using MR-J3CN2 or a junction connector as shown below. The encoder cable can be produced as the length of maximum 30 m.

### (a) Encoder cable 1

Connector set (option)  
MR-J3CN2  
Receptacle: 36210-0100PL  
Shell kit: 36310-3200-008  
(3M) (Note 2)

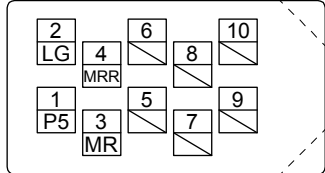

View seen from wiring side. (Note 3)

or

Connector set: 54599-1019  
(Molex) (Note 2)

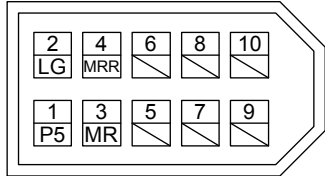

View seen from wiring side. (Note 3)

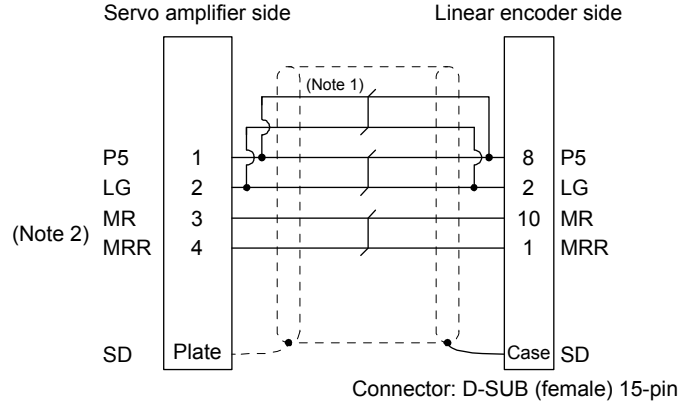

Note 1. We recommend the following specifications encoder cables.

Wiring length	Number of LG and P5 connections (when the output cable is 0.5 m or less)	Cable size
to 10 m	1-pair	AWG 22
to 20 m	2-pair	
to 30 m	3-pair	

2. For the CN2L connector, signals of pin 3 and pin 4 will be as follows.

Pin 3: MR2 Pin 4: MRR2

3. Do not connect anything to the pins shown as . Especially, pin 10 is for manufacturer adjustment. If it is connected with any other pin, the servo amplifier cannot operate normally. Referring to POINT of chapter 1, securely connect the external conductor of the shielded cable to the ground plate and fix it to the connector shell.

# 1. LINEAR ENCODER

## (b) Encoder cable 2

Connector set (option)  
 MR-J3CN2  
 Receptacle: 36210-0100PL  
 Shell kit: 36310-3200-008  
 (3M)

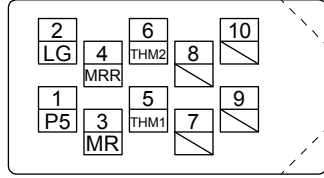

View seen from wiring side. (Note 3)

or

Connector set: 54599-1019  
 (Molex)

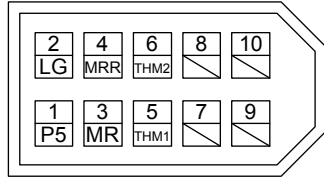

View seen from wiring side. (Note 3)

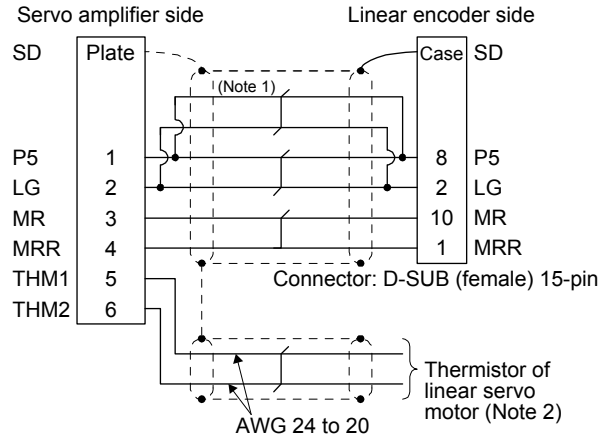

Note 1. We recommend the following specifications encoder cables.

Wiring length	Number of LG and P5 connections (when the output cable is 0.5 m or less)	Cable size
to 10 m	1-pair	AWG 22
to 20 m	2-pair	
to 30 m	3-pair	

- For wiring to the thermistor of the linear servo motor, refer to "Linear Servo Motor Instruction Manual".
- Do not connect anything to the pins shown as . Especially, pin 10 is for manufacturer adjustment. If it is connected with any other pin, the servo amplifier cannot operate normally. Referring to POINT of chapter 1, securely connect the external conductor of the shielded cable to the ground plate and fix it to the connector shell.

# 1. LINEAR ENCODER

## 1.5.2 EVOLUTE EL40M (absolute type)

**POINT**

● When the absolute position detection system is configured, the absolute position battery is not required.

(1) Cable structure

Prepare a cable based on the following configuration diagram.

(a) For the linear servo motor

- 1) MR-J4-\_A\_/MR-J4-\_B\_/MR-J4-\_GF\_/MR-J4W\_-\_B

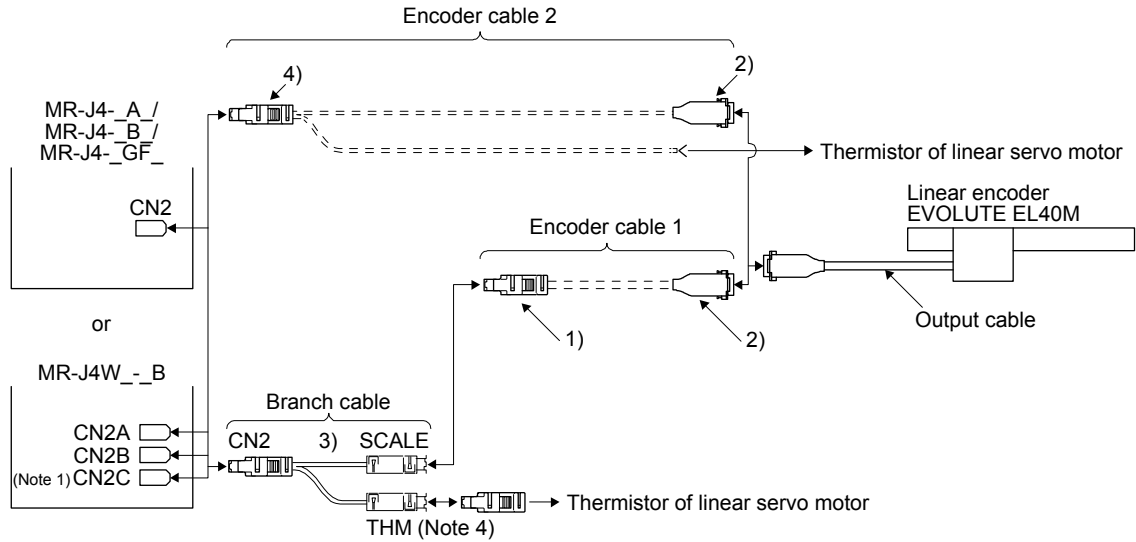

	Branch cable	Encoder cable (Note 2)		Output cable
When using a branch cable	3) MR-J4THCBL03M (Refer to section 2.4.)	1) Connector set MR-J3CN2 (Refer to (2) (a) of this section.)	2) Junction connector (Note 3) D-SUB9 pin (female)	Accessories for linear encoder Cable length: 0.5 m
When not using a branch cable		4) Connector set MR-J3CN2 (Refer to (2) (b) of this section.)		

- Note 1. The connection to CN2C is for the MR-J4 3-axis servo amplifier. MR-J4 2-axis servo amplifier does not have CN2C.  
 Note 2. Produce an encoder cable. An optional cable is not provided.  
 Note 3. It should be prepared by the customer.  
 Note 4. For connectors for thermistor signals, change how to connect depending on the customer's system.

# 1. LINEAR ENCODER

## 2) MR-J4-\_A\_-RJ/MR-J4-\_B\_-RJ/MR-J4-\_GF\_-RJ

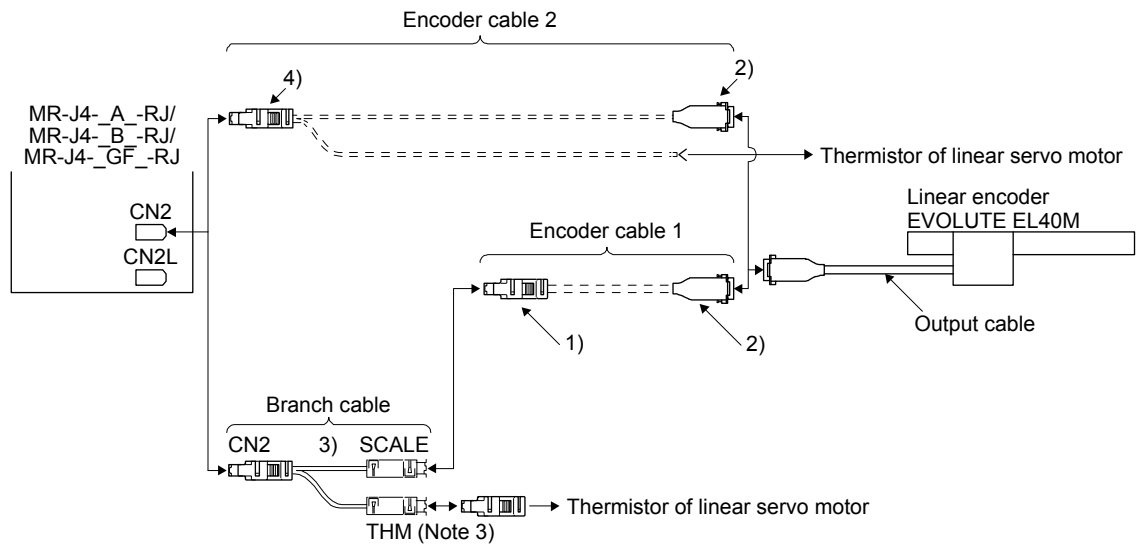

	Branch cable	Encoder cable (Note 1)		Output cable
When using a branch cable	3) MR-J4THCBL03M (Refer to section 2.4.)	1) Connector set MR-J3CN2 (Refer to (2) (a) of this section.)	2) Junction connector (Note 2) D-SUB9 pin (female)	Accessories for linear encoder Cable length: 0.5 m
When not using a branch cable		4) Connector set MR-J3CN2 (Refer to (2) (b) of this section.)		

- Note
1. Produce an encoder cable. An optional cable is not provided.
  2. It should be prepared by the customer.
  3. For connectors for thermistor signals, change how to connect depending on the customer's system.

# 1. LINEAR ENCODER

(b) When using for fully closed loop system and scale measurement function

1) MR-J4-(DU)\_A\_/MR-J4-(DU)\_B\_/MR-J4-\_GF\_/MR-J4W2-\_B

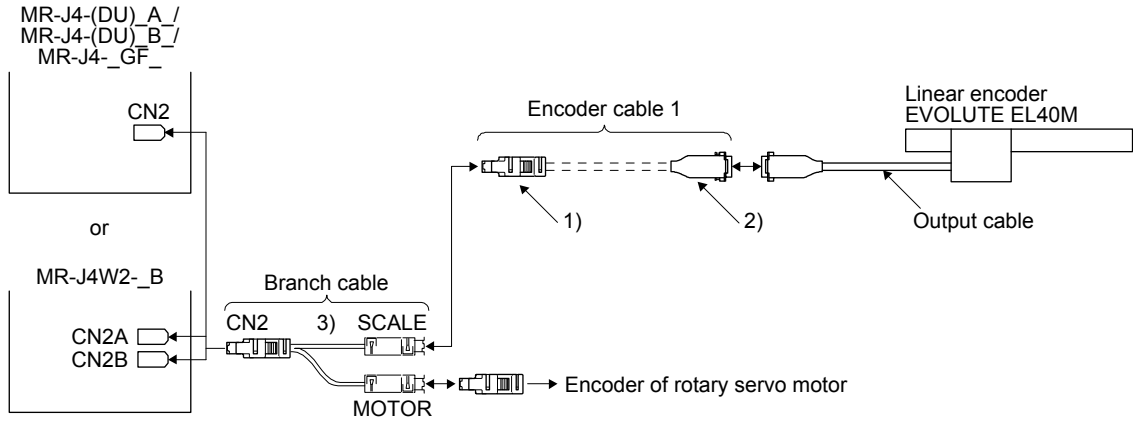

Branch cable	Encoder cable (Note 1)		Output cable
3) MR-J4FCCBL03M (Refer to section 2.5.)	1) Connector set MR-J3CN2 (Refer to (2) (a) of this section.)	2) Junction connector (Note 2) D-SUB9 pin (female)	Accessories for linear encoder Cable length: 0.5 m

Note 1. Produce an encoder cable. An optional cable is not provided.

2. It should be prepared by the customer.

2) MR-J4-(DU)\_A\_-RJ/MR-J4-(DU)\_B\_-RJ/MR-J4-\_GF\_-RJ

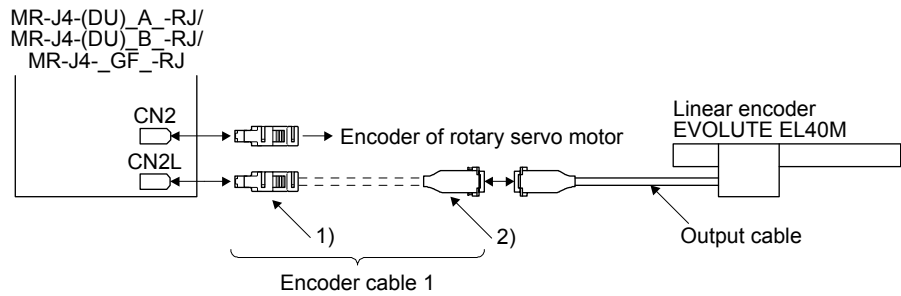

Encoder cable (Note 1)		Output cable
1) Connector set MR-J3CN2 (Refer to (2) (a) of this section.)	2) Junction connector (Note 2) D-SUB9 pin (female)	Accessories for linear encoder Cable length: 0.5 m

Note 1. Produce an encoder cable. An optional cable is not provided.

2. It should be prepared by the customer.

# 1. LINEAR ENCODER

## (2) Production of encoder cable

Produce the encoder cable using MR-J3CN2 or a junction connector as shown below. The encoder cable can be produced as the length of maximum 30 m.

### (a) Encoder cable 1

Connector set (option)  
MR-J3CN2  
Receptacle: 36210-0100PL  
Shell kit: 36310-3200-008  
(3M) (Note 2)

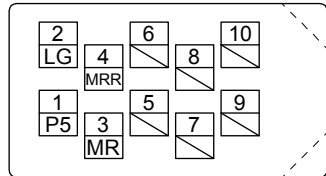

View seen from wiring side. (Note 3)

or

Connector set: 54599-1019  
(Molex) (Note 2)

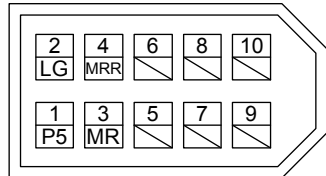

View seen from wiring side. (Note 3)

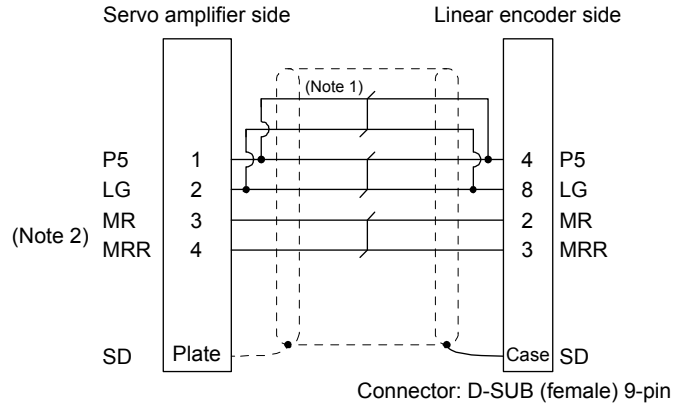

Note 1. We recommend the following specifications encoder cables.

Wiring length	Number of LG and P5 connections (when the output cable is 0.5 m or less)	Cable size
to 10 m	1-pair	AWG 22
to 20 m	2-pair	
to 30 m	3-pair	

2. For the CN2L connector, signals of pin 3 and pin 4 will be as follows.

Pin 3: MR2 Pin 4: MRR2

3. Do not connect anything to the pins shown as . Especially, pin 10 is for manufacturer adjustment. If it is connected with any other pin, the servo amplifier cannot operate normally. Referring to POINT of chapter 1, securely connect the external conductor of the shielded cable to the ground plate and fix it to the connector shell.

# 1. LINEAR ENCODER

## (b) Encoder cable 2

Connector set (option)  
 MR-J3CN2  
 Receptacle: 36210-0100PL  
 Shell kit: 36310-3200-008  
 (3M)

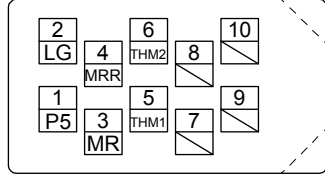

View seen from wiring side. (Note 3)

or

Connector set: 54599-1019  
 (Molex)

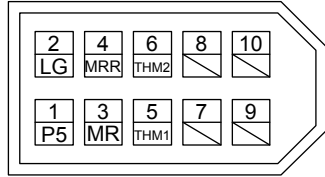

View seen from wiring side. (Note 3)

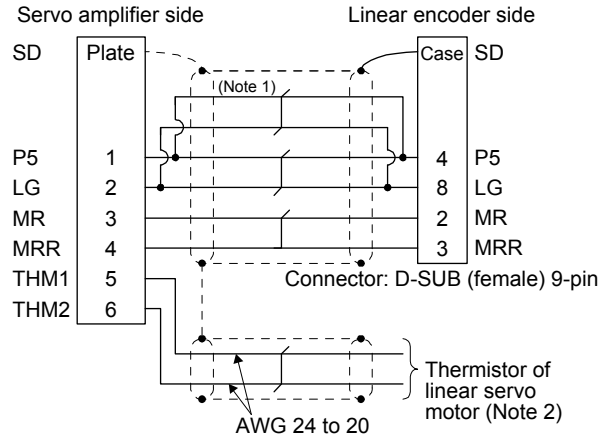

Note 1. We recommend the following specifications encoder cables.

Wiring length	Number of LG and P5 connections (when the output cable is 0.5 m or less)	Cable size
to 10 m	1-pair	AWG 22
to 20 m	2-pair	
to 30 m	3-pair	

- For wiring to the thermistor of the linear servo motor, refer to "Linear Servo Motor Instruction Manual".
- Do not connect anything to the pins shown as . Especially, pin 10 is for manufacturer adjustment. If it is connected with any other pin, the servo amplifier cannot operate normally. Referring to POINT of chapter 1, securely connect the external conductor of the shielded cable to the ground plate and fix it to the connector shell.

# 1. LINEAR ENCODER

## 1.6 Linear encoder PSLH041 manufactured by NIDEC SANKYO (Incremental type)

### (1) Cable structure

Prepare a cable based on the following configuration diagram.

#### (a) For the linear servo motor

- 1) MR-J4-\_A\_/MR-J4-\_B\_/MR-J4-\_GF\_/MR-J4W\_-\_B

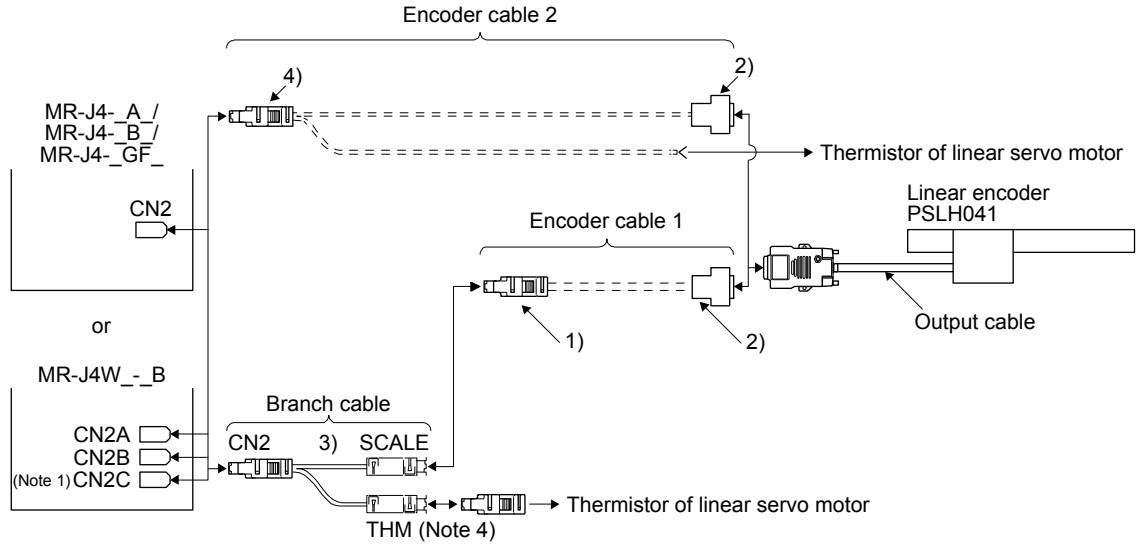

	branch cable	Encoder cable (Note 2)		Output cable
When using a branch cable	3) MR-J4THCBL03M (Refer to section 2.4.)	1) Connector set MR-J3CN2 (Refer to (2) (a) of this section.)	2) Junction connector (Note 3) D-SUB15 pin (female)	Accessories for linear encoder Cable length: 0.4 m
When not using a branch cable		4) Connector set MR-J3CN2 (Refer to (2) (b) of this section.)		

- Note
1. The connection to CN2C is for the MR-J4 3-axis servo amplifier. MR-J4 2-axis servo amplifier does not have CN2C.
  2. Produce an encoder cable. An optional cable is not provided.
  3. It should be prepared by the customer.
  4. For connectors for thermistor signals, change how to connect depending on the customer's system.

# 1. LINEAR ENCODER

## 2) MR-J4-\_A\_-RJ/MR-J4-\_B\_-RJ/MR-J4-\_GF\_-RJ

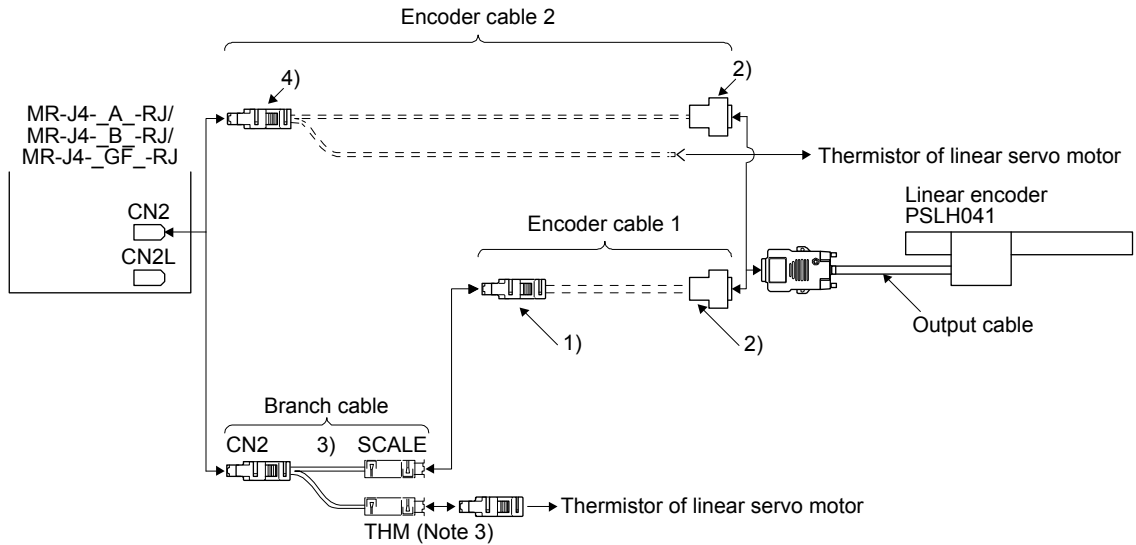

	branch cable	Encoder cable (Note 1)		Output cable
When using a branch cable	3) MR-J4THCBL03M (Refer to section 2.4.)	1) Connector set MR-J3CN2 (Refer to (2) (a) of this section.)	2) Junction connector (Note 2) D-SUB15 pin (female)	Accessories for linear encoder Cable length: 0.4 m
When not using a branch cable		4) Connector set MR-J3CN2 (Refer to (2) (b) of this section.)		

- Note 1. Produce an encoder cable. An optional cable is not provided.  
 Note 2. It should be prepared by the customer.  
 Note 3. For connectors for thermistor signals, change how to connect depending on the customer's system.

## (b) When using for fully closed loop system and scale measurement function

### 1) MR-J4-(DU)\_A\_/MR-J4-(DU)\_B\_/MR-J4-\_GF\_/MR-J4W2-\_B

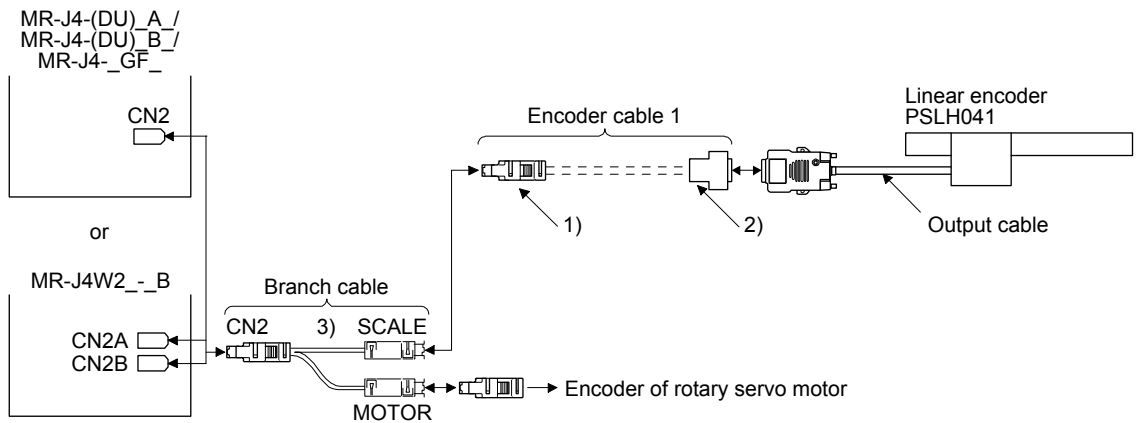

branch cable	Encoder cable (Note 1)		Output cable
3) MR-J4FCCBL03M (Refer to section 2.5.)	1) Connector set MR-J3CN2 (Refer to (2) (a) of this section.)	2) Junction connector (Note 2) D-SUB15 pin (female)	Accessories for linear encoder Cable length: 0.4 m

- Note 1. Produce an encoder cable. An optional cable is not provided.  
 Note 2. It should be prepared by the customer.

# 1. LINEAR ENCODER

## 2) MR-J4-(DU)\_A\_-RJ/MR-J4-(DU)\_B\_-RJ/MR-J4-\_GF\_-RJ

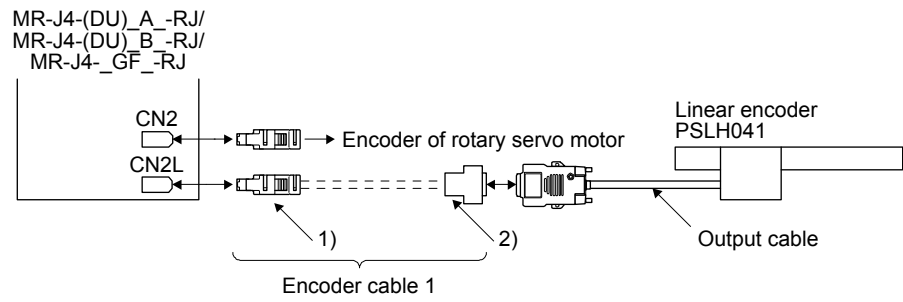

Encoder cable (Note 1)		Output cable
1) Connector set MR-J3CN2 (Refer to (2) (a) of this section.)	2) Junction connector (Note 2) D-SUB15 pin (female)	Accessories for linear encoder Cable length: 0.4 m

Note 1. Produce an encoder cable. An optional cable is not provided.  
2. It should be prepared by the customer.

# 1. LINEAR ENCODER

## (2) Fabrication of the encoder cable

Produce the load-side encoder cable using MR-J3CN2 or a junction connector as shown below. The encoder cable can be produced as the length of maximum 30 m.

### (a) Encoder cable 1

Connector set (optional)  
MR-J3CN2  
Receptacle: 36210-0100PL  
Shell kit: 36310-3200-008  
(3M)

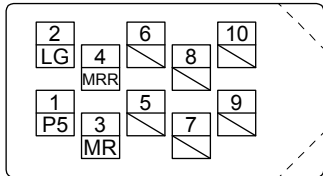

(Note 2)

View seen from the wiring side. (Note 3)

or

Connector set: 54599-1019  
(Molex)

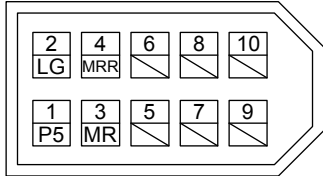

(Note 2)

View seen from the wiring side. (Note 3)

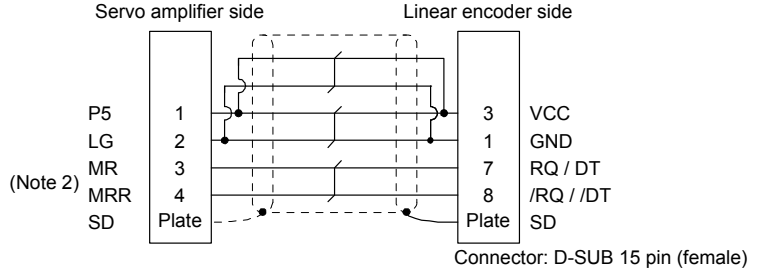

Connector: D-SUB 15 pin (female)

Note 1. We recommend the following specifications encoder cables.

Wiring length	Number of LG and P5 connections (when the output cable is 0.5 m or less)	Wire size
to 5 m	1-pair	AWG 22
to 10 m	2-pairs	
to 20 m	4-pairs	
to 30 m	5-pairs	

2. For the CN2L connector, signals of pin 3 and pin 4 will be as follows.

Pin 3: MR2

Pin 4: MRR2

3. Do not connect anything to the pins shown as . Especially, pin 10 is for manufacturer adjustment. If it is connected with any other pin, the servo amplifier cannot operate normally. Referring to POINT of chapter 1, securely connect the external conductor of the shielded cable to the ground plate and fix it to the connector shell.

# 1. LINEAR ENCODER

## (b) Encoder cable 2

Connector set (optional)  
MR-J3CN2  
Receptacle: 36210-0100PL  
Shell kit: 36310-3200-008  
(3M)

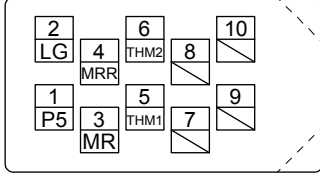

View seen from the wiring side. (Note 3)

or

Connector set: 54599-1019  
(Molex)

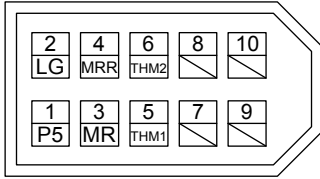

View seen from the wiring side. (Note 3)

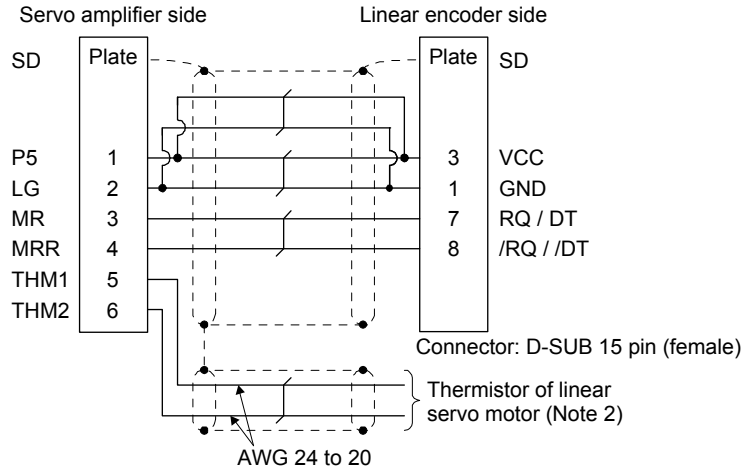

Note 1. We recommend the following specifications encoder cables.

Wiring length	Number of LG and P5 connections (when the output cable is 0.5 m or less)	Wire size
to 5 m	1-pair	AWG 22
to 10 m	2-pairs	
to 20 m	4-pairs	
to 30 m	5-pairs	

- For wiring to the thermistor of the linear servo motor, refer to "Linear Servo Motor Instruction Manual".
- Do not connect anything to the pins shown as . Especially, pin 10 is for manufacturer adjustment. If it is connected with any other pin, the servo amplifier cannot operate normally. Referring to POINT of chapter 1, securely connect the external conductor of the shielded cable to the ground plate and fix it to the connector shell.

# 1. LINEAR ENCODER

## 1.7 A/B/Z-phase differential output linear encoder

**POINT**

● When using a linear encoder of A/B/Z-phase differential output method, use an MR-J4-(DU)\_A\_-RJ/MR-J4-(DU)\_B\_-RJ.

This section explains the connection of the A/B/Z-phase differential output linear encoder. Prepare the MR-J3CN2 connector set for the encoder cable and fabricate it according to the wiring diagram in (3) of this section.

### (1) A/B/Z-phase differential output linear encoder specifications

Each signal of the A, B, and Z-phase of the linear encoder is provided in the differential line driver output. It cannot be provided in the collector output.

The phase differences of the A-phase and B-phase pulses and the pulse width of the Z-phase pulse need to be 200 ns or more.

The output pulse of A-phase and B-phase of the A/B/Z-phase differential output linear encoder is in the multiply-by-four count method.

The linear encoder without Z-phase cannot make a home position return.

The tolerable resolution range is between 0.001  $\mu\text{m}$  and 5  $\mu\text{m}$ . Please select a linear encoder within the range.

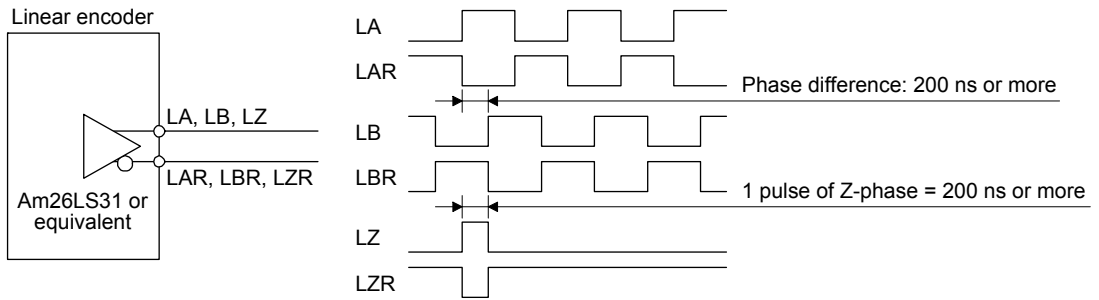

### (2) Connection of servo amplifier and A/B/Z-phase differential output linear encoder

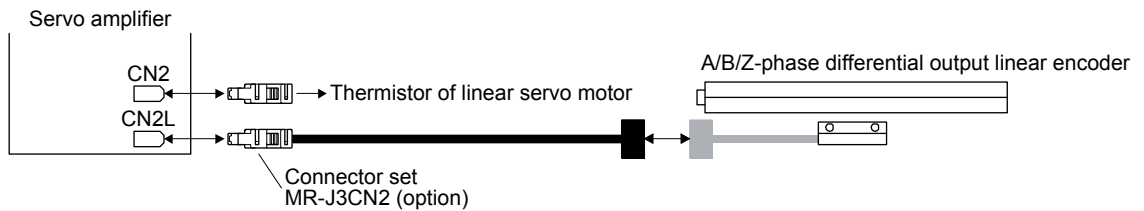

# 1. LINEAR ENCODER

## (3) Internal wiring diagram

For fabrication, use a cable durable against the long period of bending action. Even though the cable length is max. 30 m for the RS-422 communication, the length may be shortened due to the power supply voltage drop or the specifications of linear encoder.

A connection example is shown below. Contact each linear encoder manufacturer for details.

### 1) When the consumption current of the linear encoder is 350 mA or less

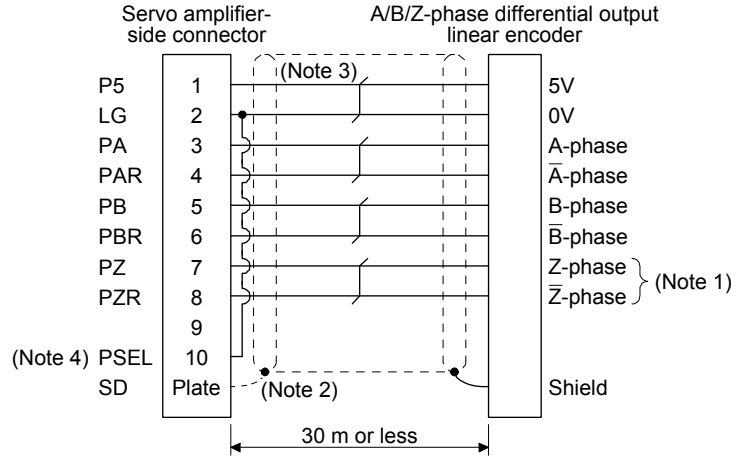

- Note 1. For the encoder without Z-phase, set [Pr. PC45] (MR-J4-\_A\_-RJ) or [Pr. PC27] (MR-J4-\_B\_-RJ/MR-J4-\_GF\_-RJ) to "\_1\_".
- Note 2. Securely connect a shielded wire to the plate (ground plate) in the connector.
- Note 3. We recommend the following specifications encoder cables for the linear encoder which consumption current is 350 mA. When the consumption current of the encoder is less than 350 mA, the paired connections can be decreased.
- Note 4. When using an A/B/Z-phase differential output linear encoder, connect PSEL to the LG terminal.

Wiring length	Number of LG and P5 connections	Cable size
to 5 m	2-pair	AWG 22
to 10 m	3-pair	
to 20 m	6-pair	
to 30 m	8-pair	

# 1. LINEAR ENCODER

2) When the consumption current of the linear encoder is more than 350 mA

**POINT**

● When turning on the power, turn on the linear encoder and then turn on the servo amplifier. When turning off the power, turn off the servo amplifier and then turn off the linear encoder.

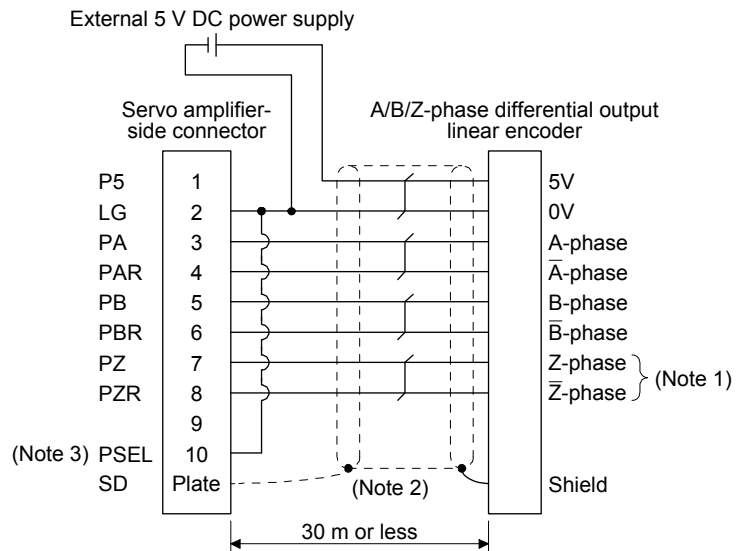

- Note 1. For the encoder without Z-phase, set [Pr. PC45] (MR-J4-\_A\_-RJ) or [Pr. PC27] (MR-J4-\_B\_-RJ/MR-J4-\_GF\_-RJ) to "\_1\_".
- Note 2. Securely connect a shielded wire to the plate (ground plate) in the connector.
- Note 3. When using an A/B/Z-phase differential output linear encoder, connect PSEL to the LG terminal.

## 2. OPTION CABLE/CONNECTOR SETS

### 2. OPTION CABLE/CONNECTOR SETS

#### 2.1 MR-EKCBL\_M-H encoder cable

##### (1) Model explanations

Model: MR-EKCBL 2 M-H

Long bending life

Symbol	Cable length [m]
2	2
5	5

##### (2) Cable structure

The table shows this optional cable structure.

IP rating	Bending life	Length [m]	Core size [mm <sup>2</sup> ]	Number of cores	Characteristics of one core			(Note 2) Cable OD [mm]	Wire model (manufacturer)
					Structure [Wires/mm]	Conductor resistance [Ω/km]	(Note 1) Insulation coating OD d [mm]		
IP20	Long bending life	2/5	0.2	12 (6 pairs)	40/0.08	105 or less	0.88	7.2	(Note 3) A14B2339 6P (Junkosha)

Note 1. d is as shown below.

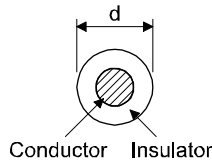

2. Standard OD. Maximum OD is about 10% greater.
3. Purchase from Toa Electric Industrial



Cable model	1) SCALE-side connector of branch cable	2) Junction connector
MR-EKCBL_M-H	<p>Receptacle: 36210-0100PL Shell kit: 36310-3200-008 (3M)</p> <div style="display: flex; justify-content: space-around;"> <div style="text-align: center;"> <p>View seen from wiring side. (Note)</p> </div> <div style="text-align: center;"> <p>View seen from wiring side. (Note)</p> </div> </div> <p>or</p> <div style="text-align: center;"> <p>View seen from wiring side. (Note)</p> </div> <p>Note. Keep open the pins shown with . Especially, pin 10 is provided for manufacturer adjustment. If it is connected with any other pin, the servo amplifier cannot operate normally. Referring to POINT of chapter 1, securely connect the external conductor of the shielded cable to the ground plate and fix it to the connector shell.</p>	<p>Housing: 1-172161-9 Connector pin: 170359-1 (TE Connectivity or equivalent) Cable clamp: MTI-0002 (Toa Electric Industrial)</p> <div style="text-align: center;"> <p>View seen from wiring side.</p> </div>

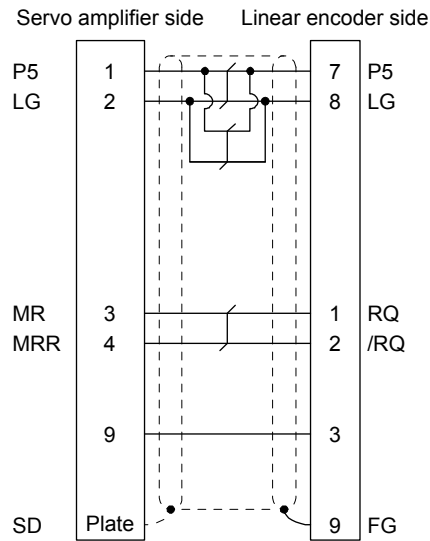

## 2. OPTION CABLE/CONNECTOR SETS

### (3) Internal wiring diagram



### 2.2 MR-ECNM connector set

The following shows the connector combination for this connector set.

IP rating	Parts	Description
IP20	Connector set	<p>MR-ECNM</p>   <p>SCALE-side connector of branch cable                      Receptacle: 36210-0100PL                      Shell kit: 36310-3200-008                      (3M)                      or                      Connector set: 54599-1019                      (Molex)</p> <p>Junction connector                      Housing: 1-172161-9                      Connector pin: 170359-1                      (TE Connectivity or equivalent)                      Cable clamp: MTI-0002                      (Toa Electric Industrial)</p>

### 2.3 MR-J3CN2 connector set

The following shows the details of this connector set.

Connector set  
 MR-J3CN2  
 Receptacle: 36210-0100PL  
 Shell kit: 36310-3200-008  
 (3M or equivalent)

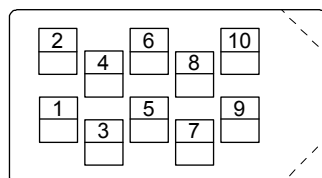

View seen from wiring side.

Connector set: 54599-1019  
 (Molex)

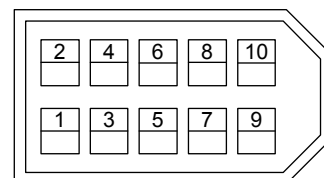



View seen from wiring side.

## 2. OPTION CABLE/CONNECTOR SETS

### 2.4 MR-J4THCBL03M branch cable

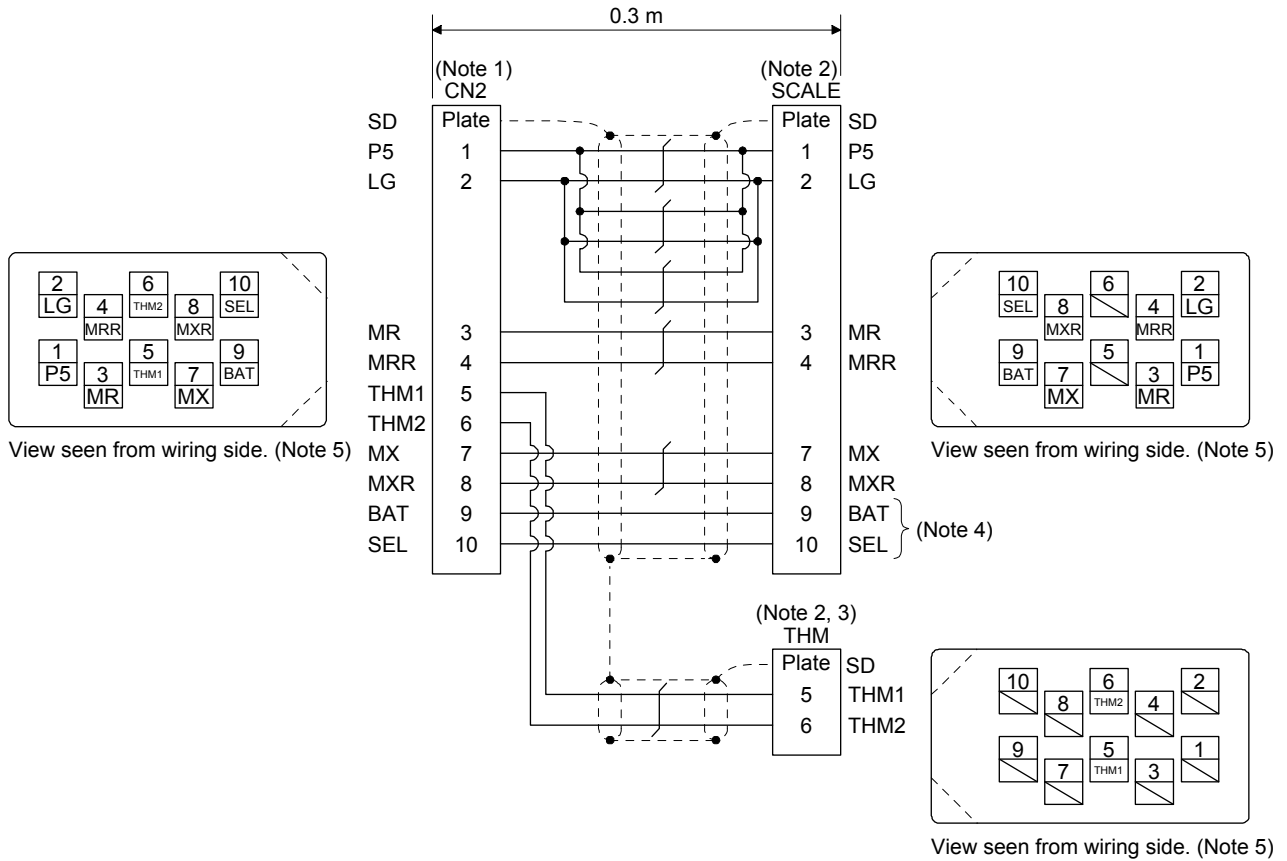
This branch cable is for connecting the thermistor of linear servo motor and the linear encoder to CN2 connector. When fabricating the branch cable using MR-J3THMCN2 connector set, refer to App. 1.



- Note 1. Receptacle: 36210-0100PL, shell kit: 36310-3200-008 (3M)  
 Note 2. Plug: 36110-3000FD, shell kit: 36310-F200-008 (3M)  
 Note 3. For connectors for thermistor signals, change how to connect depending on the customer's system.  
 Note 4. When fabricating the cable, you do not need to wire these signals for the manufacturer.  
 Note 5. Do not connect anything to the pins shown as . Especially, pin 10 is for manufacturer adjustment. If it is connected with any other pin, the servo amplifier cannot operate normally. Referring to POINT of chapter 1, securely connect the external conductor of the shielded cable to the ground plate and fix it to the connector shell.

## 2. OPTION CABLE/CONNECTOR SETS

### 2.5 MR-J4FCCBL03M branch cable

This branch cable is for connecting the encoder of rotary servo motor and the load-side encoder to CN2 connector. When fabricating the branch cable using MR-J3THMCN2 connector set, refer to App. 2.

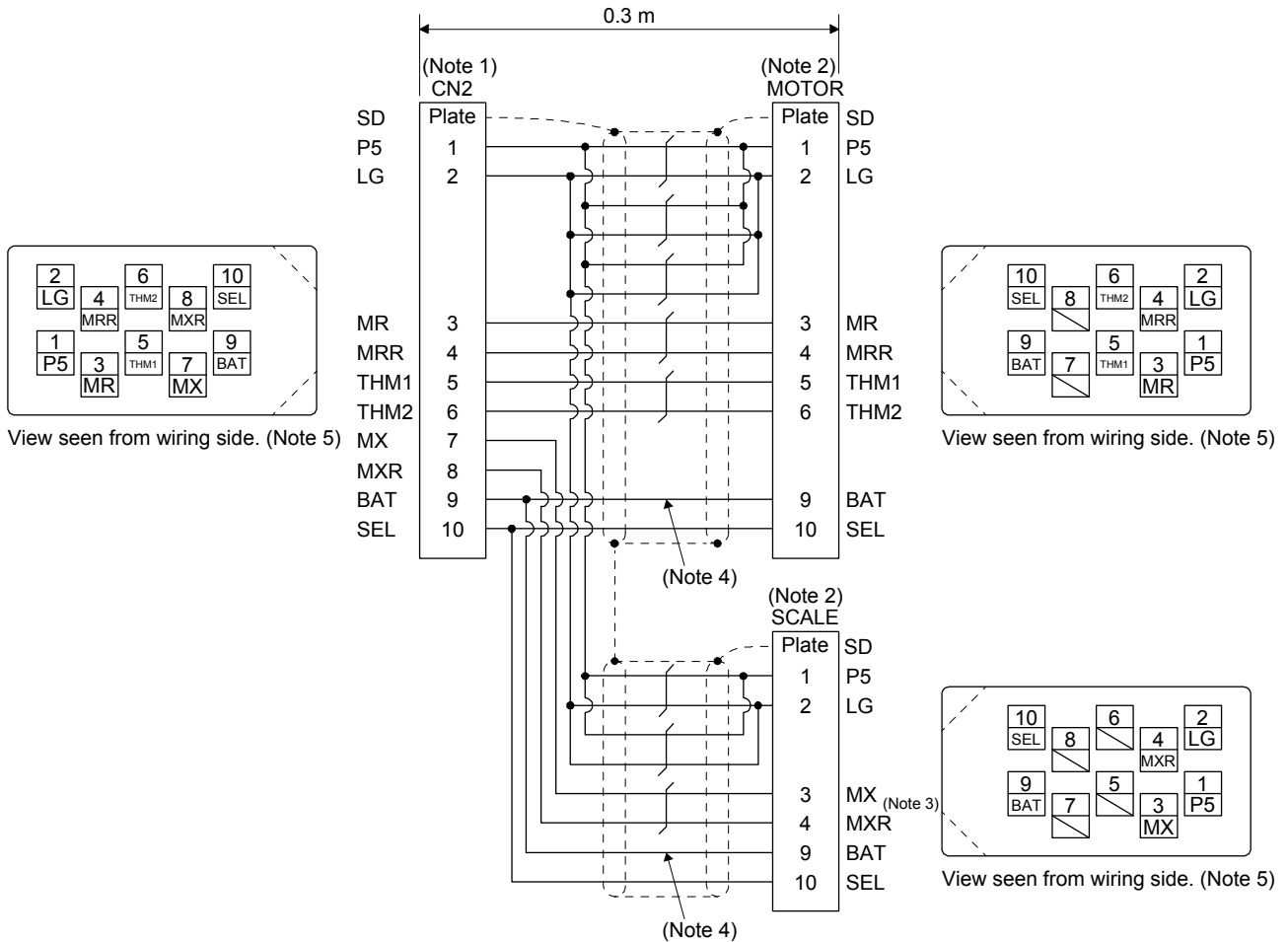

- Note 1. Receptacle: 36210-0100PL, shell kit: 36310-3200-008 (3M)
- Note 2. Plug: 36110-3000FD, shell kit: 36310-F200-008 (3M)
- Note 3. Connect MX to MR of the linear encoder cable, and MXR to MRR of the cable.
- Note 4. Always make connection for use in an absolute position detection system. Wiring is not necessary for use in an incremental system.
- Note 5. Do not connect anything to the pins shown as . Especially, pin 10 is for manufacturer adjustment. If it is connected with any other pin, the servo amplifier cannot operate normally. Referring to POINT of chapter 1, securely connect the external conductor of the shielded cable to the ground plate and fix it to the connector shell.

### 3. DETAILED EXPLANATION OF [AL. 2A LINEAR ENCODER ERROR 1]

### 3. DETAILED EXPLANATION OF [AL. 2A LINEAR ENCODER ERROR 1]

If the cause of [AL. 2A Linear encoder error 1] occurrence is not identified, confirm the alarm display details of MR Configurator2, and contact each manufacturer.

Table 3.1 Detailed explanation of [AL. 2A Linear encoder error 1] for each manufacturer

Alarm No.	Detail information No.	[AL. 2A Linear encoder error 1] details						
		Mitutoyo		Magnescale		Heidenhain	Renishaw	NIDEC SANKYO
		AT343A/AT54_A	ST74_A/ST134_A	SR_7	SR_5/SL710/SQ10		RESOLUTE/EVOLUTE	PSLH041
2A.1	01	Initialization error	Overspeed error	Laser diode error		Initialization error	Initial error	EEP-ROM error
2A.2	02	Photoelectric capacitive data mismatch	Initialization error	Encoder mismatch error	Encoder warning	Scale level error INC/ABS data mismatch error		Temperature error
2A.3	03	Photoelectric error	Hardware error	Incremental signal error		INC data error		Speed error
2A.4	04	Capacitive error	ABS detection error	Absolute signal error		ABS data error	Absolute signal error	Offset error
2A.5	05	CPU error	Transducer error			CPU error		Amplitude error
2A.6	06	EEP-ROM error	Signal strength error	System memory error	Encoder alarm	EEP-ROM error	Thermal alarm	
2A.7	07	ROM/RAM error	Signal strength alarm					
2A.8	08	Optical overspeed	Thermal alarm	Speed error		Overspeed error	Overspeed	

As an example, the following describes the detailed information when [AL. 2A Linear encoder error 1] occurs in the linear encoder AT343A manufactured by Mitutoyo.

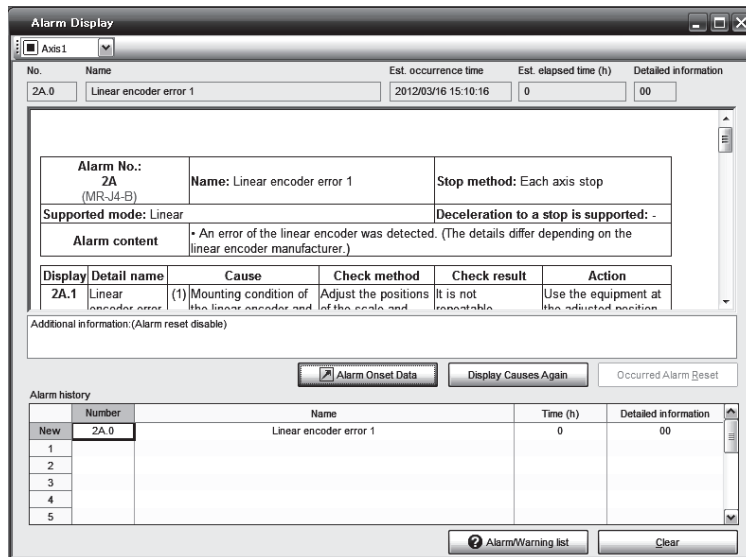



# APPENDIX

## APPENDIX

### App. 1 Production of branch cable for linear servo motor

Produce the branch cable using MR-J3THMCN2 connector set as shown in the connection diagram in section 2.4.

The branch cable length should be 0.3 m or less.

Parts	Description
MR-J3THMCN2 connector set	 Receptacle: 36210-0100PL Shell kit: 36310-3200-008 (3M) or connector set: 54599-1019 (Molex) Plug: 36110-3000FD Shell kit: 36310-F200-008 (3M)
Cable	ETFE-SVP 40/0.08mm (AWG#24 or equivalent)*6P (Toa Electric Industrial Co. Ltd., Nagoya Branch) VSVC 7/0.18mm × 2C (AWG#26 or equivalent) (Toa Electric Industrial Co. Ltd., Nagoya Branch)

### App. 2 Production of branch cable for fully closed loop control system

Produce the branch cable using MR-J3THMCN2 connector set as shown in the connection diagram in section 2.5.

The branch cable length should be 0.3 m or less.

Parts	Description
MR-J3THMCN2 connector set	 Receptacle: 36210-0100PL Shell kit: 36310-3200-008 (3M) or connector set: 54599-1019 (Molex) Plug: 36110-3000FD Shell kit: 36310-F200-008 (3M)
Cable	ETFE-SVP 40/0.08mm (AWG#24 or equivalent)*6P (Toa Electric Industrial Co. Ltd., Nagoya Branch) VSVP 7/0.16(AWG#26 or equivalent)-4P (Toa Electric Industrial Co. Ltd., Nagoya Branch)

### App. 3 Manufacturer list

Names given in the table are as of December 2016.

Manufacturer	Contact
3M	3M
TE Connectivity	TE Connectivity
Toa Electric Industrial	Toa Electric Industrial Co., Ltd.
Heidenhain	Heidenhain
Hirose Electric	Hirose Electric Co., Ltd.
Magnescale	Magnescale Co., Ltd.
Mitutoyo	Mitutoyo Corporation
Molex	Molex
Renishaw	Renishaw
NIDEC SANKYO	NIDEC SANKYO CORPORATION

## REVISIONS

\*The manual number is given on the bottom left of the back cover.

Revision Date	*Manual Number	Revision	
Mar. 2012	SH(NA)030111ENG-A	First edition	
May 2012	SH(NA)030111ENG-B	Chapter 1	POINT is changed.
		Section 1.2.1 (1)	Drawing and table are changed.
		Section 1.2.1 (2) (b)	Added.
		Section 1.2.2 (1)	Drawing and table are changed.
		Section 1.2.2 (2) (b)	Added.
		Section 1.2.3 (1)	Drawing and table are changed.
		Section 1.2.3 (2) (b)	Added.
		Section 1.3.1 (1)	Drawing and table are changed.
		Section 1.3.1 (2) (b)	Added.
		Section 1.3.2 (1)	Drawing and table are changed.
		Section 1.3.2 (2) (b)	Added.
		Section 1.4.1 (1) (a)	CAUTION is added.
		Section 1.4.2 (1)	Drawing and table are changed.
		Section 1.4.2 (2) (b)	Added.
		Section 1.5.1 (1)	Drawing and table are changed.
		Section 1.5.1 (2) (b)	Added.
		Section 1.5.2 (1)	Drawing and table are changed.
		Section 1.5.2 (2) (b)	Added.
		Section 2.4	CAUTION is added.
Feb. 2013	SH(NA)030111ENG-C	Chapter 1	POINT is changed.
		Section 1.1	Table is changed, (1) and (2) are added.
		Section 1.2.1 (1)	MR-J4-A is added to 1) of (a) and (b). 2) is added.
		Section 1.2.1 (2)	The titles of (a) and (b) are changed. Note is added to (a).
		Section 1.2.2 (1)	MR-J4-A is added to 1) of (a) and (b). 2) is added.
		Section 1.2.2 (2)	The titles of (a) and (b) are changed. Note is added to (a).
		Section 1.2.3 (1)	MR-J4-A is added to 1) of (a) and (b). 2) is added.
		Section 1.2.3 (2)	The titles of (a) and (b) are changed. Note is added to (a).
		Section 1.3.1 (1)	MR-J4-A is added to 1) of (a) and (b). 2) is added.
		Section 1.3.1 (2)	The titles of (a) and (b) are changed. Note is added to (a).
		Section 1.3.2 (1)	MR-J4-A is added to 1) of (a) and (b). 2) is added.
		Section 1.3.2 (2)	The titles of (a) and (b) are changed. Note is added to (a).
		Section 1.4.1 (1)	MR-J4-A is added to 1) of (a) and (b). 2) is added.
		Section 1.4.2 (1)	MR-J4-A is added to 1) of (a) and (b). 2) is added.
		Section 1.4.2 (2)	The titles of (a) and (b) are changed. Note is added to (a).
		Section 1.5.1 (1)	MR-J4-A is added to 1) of (a) and (b). 2) is added.
		Section 1.5.1 (2)	The titles of (a) and (b) are changed. Note is added to (a).
		Section 1.5.2 (1)	MR-J4-A is added to 1) of (a) and (b). 2) is added.
		Section 1.5.2 (2)	The titles of (a) and (b) are changed. Note is added to (a).
		Section 1.6	Added.
Aug. 2013	SH(NA)030111ENG-D	Section 1.1 (1) (2)	The table is changed.
		Section 1.2.1 (1) (a) 2)	The illustration is changed.
		Section 1.2.2 (1) (a) 2)	The illustration is changed.
		Section 1.2.3 (1) (a) 2)	The illustration is changed.
		Section 1.3.1 (1) (b)	The illustration is changed.
		Section 1.3.2 (1) (b)	The illustration is changed.
		Section 1.4.1 (1) (a) 2)	The illustration is changed.
		Section 1.4.2 (1) (a) 2)	The illustration is changed.
		Section 1.5.1 (1) (a) 2)	The illustration is changed.
		Section 1.5.2 (1) (a) 2)	The illustration is changed.
		Section 1.6 (2)	The illustration is changed.

Revision Date	*Manual Number	Revision
Mar. 2014	SH(NA)030111ENG-E	Section 1.1 (1) Changed.
Sep. 2014	SH(NA)030111ENG-F	Encoder and large capacity servo amplifiers are added. Chapter 1 POINT is added. Section 1.2.1 (2) Note is added. Section 1.2.2 (2) Note is added. Section 1.2.3 (2) Note is added. Section 1.3.1 (2) Note is added. Section 1.3.2 (2) Note is added. Section 1.3.3 (2) Note is added. Section 1.4.2 (2) Note is added. Section 1.5 (2) Note is added. Section 1.6 Added. Section 2.1 (2) Note is partially changed. Section 2.4 Note is added. Section 2.5 Note is added. Chapter 3 The table is partially changed. App. 3 Partially added.
Feb. 2016	SH(NA)030111ENG-G	MR-J4-GF is added, and linear encoder is added. Chapter 1 POINT is added. Section 1.1 Added. Partially changed. Section 1.2.1 MR-J4-GF is added. Section 1.2.2 MR-J4-GF is added. Section 1.2.3 MR-J4-GF is added. Section 1.2.4 Added. Section 1.3.1 Model names are changed. Section 1.3.2 Model names are added. Partially changed. Section 1.3.3 MR-J4-GF is added. Partially changed. Section 1.4 Model names are added. Section 1.4.1 MR-J4-GF is added. Section 1.4.2 MR-J4-GF is added. Section 1.4.3 Added. Section 1.4.4 Added. Section 1.5.1 MR-J4-GF is added. Section 1.5.2 Added. Section 1.6 MR-J4-GF is added. Section 1.7 (3) Note is added. Chapter 3 Model names are added. App. 3 Partially changed.
Dec. 2016	SH(NA)030111ENG-H	"Available in the future" for MR-J4-GF is deleted. Front cover "Available in the future" is deleted. Section 1.1 Partially changed. Section 1.2.4 Partially added.
Nov. 2025	SH(NA)030111ENG-J	The back cover is changed.

This manual confers no industrial property rights or any rights of any other kind, nor does it confer any patent licenses. Mitsubishi Electric Corporation cannot be held responsible for any problems involving industrial property rights which may occur as a result of using the contents noted in this manual.

## Warranty

### 1. Warranty period and coverage

We will repair any failure or defect hereinafter referred to as "failure" in our FA equipment hereinafter referred to as the "Product" arisen during warranty period at no charge due to causes for which we are responsible through the distributor from which you purchased the Product or our service provider. However, we will charge the actual cost of dispatching our engineer for an on-site repair work on request by customer in Japan or overseas countries. We are not responsible for any on-site readjustment and/or trial run that may be required after a defective unit are repaired or replaced.

### [Term]

For terms of warranty, please contact your original place of purchase.

### [Limitations]

- (1) You are requested to conduct an initial failure diagnosis by yourself, as a general rule.  
It can also be carried out by us or our service company upon your request and the actual cost will be charged. However, it will not be charged if we are responsible for the cause of the failure.
- (2) This limited warranty applies only when the condition, method, environment, etc. of use are in compliance with the terms and conditions and instructions that are set forth in the instruction manual and user manual for the Product and the caution label affixed to the Product.
- (3) Even during the term of warranty, the repair cost will be charged on you in the following cases;
  - (i) a failure caused by your improper storing or handling, carelessness or negligence, etc., and a failure caused by your hardware or software problem
  - (ii) a failure caused by any alteration, etc. to the Product made on your side without our approval
  - (iii) a failure which may be regarded as avoidable, if your equipment in which the Product is incorporated is equipped with a safety device required by applicable laws and has any function or structure considered to be indispensable according to a common sense in the industry
  - (iv) a failure which may be regarded as avoidable if consumable parts designated in the instruction manual, etc. are duly maintained and replaced
  - (v) any replacement of consumable parts (battery, fan, smoothing capacitor, etc.)
  - (vi) a failure caused by external factors such as inevitable accidents, including without limitation fire and abnormal fluctuation of voltage, and acts of God, including without limitation earthquake, lightning and natural disasters
  - (vii) a failure generated by an unforeseeable cause with a scientific technology that was not available at the time of the shipment of the Product from our company
  - (viii) any other failures which we are not responsible for or which you acknowledge we are not responsible for

### 2. Term of warranty after the stop of production

- (1) We may accept the repair at charge for another seven (7) years after the production of the product is discontinued. The announcement of the stop of production for each model can be seen in our Sales and Service, etc.
- (2) Please note that the Product (including its spare parts) cannot be ordered after its stop of production.

### 3. Service in overseas countries

Our regional FA Center in overseas countries will accept the repair work of the Product. However, the terms and conditions of the repair work may differ depending on each FA Center. Please ask your local FA center for details.

### 4. Exclusion of loss in opportunity and secondary loss from warranty liability

Regardless of the gratis warranty term, Mitsubishi shall not be liable for compensation to:

- (1) Damages caused by any cause found not to be the responsibility of Mitsubishi.
- (2) Loss in opportunity, lost profits incurred to the user by Failures of Mitsubishi products.
- (3) Special damages and secondary damages whether foreseeable or not, compensation for accidents, and compensation for damages to products other than Mitsubishi products.
- (4) Replacement by the user, maintenance of on-site equipment, start-up test run and other tasks.

### 5. Change of Product specifications

Specifications listed in our catalogs, manuals or technical documents may be changed without notice.

### 6. Application and use of the Product

- (1) For the use of our General-Purpose AC Servo, its applications should be those that may not result in a serious damage even if any failure or malfunction occurs in General-Purpose AC Servo, and a backup or fail-safe function should operate on an external system to General-Purpose AC Servo when any failure or malfunction occurs.
- (2) Our General-Purpose AC Servo is designed and manufactured as a general purpose product for use at general industries. Therefore, applications substantially influential on the public interest for such as atomic power plants and other power plants of electric power companies, and also which require a special quality assurance system, including applications for railway companies and government or public offices are not recommended, and we assume no responsibility for any failure caused by these applications when used  
In addition, applications which may be substantially influential to human lives or properties for such as airlines, medical treatments, railway service, incineration and fuel systems, man-operated material handling equipment, entertainment machines, safety machines, etc. are not recommended, and we assume no responsibility for any failure caused by these applications when used. We will review the acceptability of the abovementioned applications, if you agree not to require a specific quality for a specific application. Please contact us for consultation.
- (3) Mitsubishi Electric shall have no responsibility or liability for any problems involving programmable controller trouble and system trouble caused by DoS attacks, unauthorized access, computer viruses, and other cyberattacks.

SH(NA)030111ENG-J(2511)MEE

MODEL: LINEAR ENCODER INSTRUCTION MANUAL

MODEL CODE: 1CW947

## **MITSUBISHI ELECTRIC CORPORATION**

HEAD OFFICE: TOKYO BLDG., 2-7-3, MARUNOUCHI, CHIYODA-KU, TOKYO 100-8310, JAPAN  
NAGOYA WORKS: 1-14, YADA-MINAMI 5-CHOME, HIGASHI-KU, NAGOYA 461-8670, JAPAN

When exported from Japan, this manual does not require application to the  
Ministry of Economy, Trade and Industry for service transaction permission.

Specifications subject to change without notice.

Compliance with the indicated global standards and regulations is current as of the release date of this manual.