

## General-Purpose AC Servo

MITSUBISHI ELECTRIC SERVO SYSTEM  
**MELSERVO**

# Linear Servo Motor Instruction Manual

---

-LM-H3  
-LM-U2  
-LM-F  
-LM-K2

## ● Safety Instructions ●

Please read the instructions carefully before using the equipment.

To use the equipment correctly, do not attempt to install, operate, maintain, or inspect the equipment until you have read through this Instruction Manual and appended documents carefully. Do not use the equipment until you have a full knowledge of the equipment, safety information and instructions.

In this Instruction Manual, the safety instruction levels are classified into "WARNING" and "CAUTION".



Indicates that incorrect handling may cause hazardous conditions, resulting in death or severe injury.



Indicates that incorrect handling may cause hazardous conditions, resulting in medium or slight injury to personnel or may cause physical damage.

Note that the CAUTION level may lead to a serious consequence according to conditions.

Please follow the instructions of both levels because they are important to personnel safety.

What must not be done and what must be done are indicated by the following diagrammatic symbols.



Indicates what must not be done. For example, "No Fire" is indicated by .



Indicates what must be done. For example, grounding is indicated by .

In this Instruction Manual, instructions at a lower level than the above, instructions for other functions, and so on are classified into "POINT".

After reading this Instruction Manual, keep it accessible to the operator.

## 1. To prevent electric shock, note the following

### WARNING

- Before wiring or inspection, turn off the power and wait for 15 minutes or more until the charge lamp turns off. Then, confirm that the voltage between P+ and N- is safe with a voltage tester and others. Otherwise, an electric shock may occur. In addition, when confirming whether the charge lamp is off or not, always confirm it from the front of the servo amplifier.
- To avoid an electric shock, insulate the connections of the power supply terminals.
- Ground the servo amplifier and the linear servo motor securely.
- Any person who is involved in wiring and inspection should be fully competent to do the work.
- Do not attempt to wire the servo amplifier and the linear servo motor until they have been installed. Otherwise, it may cause an electric shock.
- The cables should not be damaged, stressed, loaded, or pinched. Otherwise, it may cause an electric shock.

## 2. To prevent fire, note the following

### CAUTION

- Install the servo amplifier, linear servo motor, and regenerative resistor on incombustible material. Installing them directly or close to combustibles will lead to a fire or smoke generation.
- Provide adequate protection to prevent screws and other conductive matter, oil and other combustible matter from entering the servo amplifier and the linear servo motor.

## 3. To prevent injury, note the following

### WARNING

- The linear servo motor contains a strong magnet on the secondary side. Therefore, not only the linear servo motor installation operators but also the machine operators must use abundance of caution. For example, one who uses a medical device like a pacemaker must keep away from the machine.
- The permanent magnet on the secondary side makes the magnetic bodies generate attraction force. Be careful not to get your hand stuck.
- The performance is not guaranteed if the specified servo amplifier and linear servo motor are not combined. If used with unspecified combination, the servo amplifier or linear servo motor may be damaged. Depending on the case, it can be out of control and operate unexpectedly, resulting in extremely dangerous condition.
- Under the packaged condition (cardboard) delivered from our company, the magnet on the secondary side does not have a serious effect on the outside. Before mounting to the machine, however, magnetic bodies (including tools) must be kept away from the secondary side. The magnet face side of secondary side has strong magnetic attraction force, which may cause a serious injury. To avoid any injury, be cautious in the workplace and around it.

## CAUTION

- Only the power/signal specified in the Instruction Manual must be supplied/applied to each terminal. Otherwise, an electric shock, fire, injury, etc. may occur.
- Connect cables to the correct terminals. Otherwise, a burst, damage, etc. may occur.
- Ensure that polarity (+/-) is correct. Otherwise, a burst, damage, etc. may occur.
- The servo amplifier heat sink, regenerative resistor, linear servo motor, etc. may be hot while power is on or for some time after power-off. Take safety measures, e.g. provide covers, to prevent accidental contact of hands and parts (cables, etc.) with them.
- The linear servo motor installation operators and machine operators must not work wearing electronic devices (watch, calculator, personal computer, etc.) and magnetic recording media (IC card, magnetic card, floppy disc, etc.) and must not bring them around a magnetic. The magnetic influence may cause the operation failure or malfunction.
- Securely fix the linear servo motor to the machine. If being fixed insecurely, the linear servo motor may come off during operation, leading to injury.

## 4. Additional instructions

The following instructions should also be fully noted. Incorrect handling may cause a malfunction, injury, electric shock, fire, etc.

### (1) Transportation and installation

## CAUTION

- Transport the products correctly according to their mass.
- Do not overtighten the eyebolts of the linear servo motor. Tightening too hard may damage the tap.
- Stacking in excess of the specified number of product packages is not allowed.
- Do not hold the cables or connectors when carrying the linear servo motor. Otherwise, it may drop.
- Install the servo amplifier and the linear servo motor in a load-bearing place in accordance with the Instruction Manual.
- Do not get on or put heavy load on the equipment. Otherwise, it may cause injury.
- The equipment must be installed in the specified direction.
- Do not install or operate the servo amplifier and the linear servo motor which have been damaged or have any parts missing.
- Do not drop or apply heavy impact on the servo amplifiers and the linear servo motors. Otherwise, injury, malfunction, etc. may occur.
- The IP rating of the linear servo motor is IP00. Take necessary measures against dust, oil, etc. (Refer to section 1.2 Instructions on design.)
- When mounting the secondary side, use nonmagnetic tools.
- Securely fix the linear servo motor to the machine. If being fixed insecurely, the linear servo motor may come off during operation, leading to injury.
- Do not modify the linear servo motor.
- Take safety measures, e.g. provide covers, to prevent accidental access to the linear servo motor during operation.

## CAUTION

- The dynamic brake can be applied by the servo amplifier, but the coasting distance becomes longer when the moving body is heavy or when the speed is high. It may result in crashing into the stroke end, which is highly dangerous. Install the anti-crash mechanism such as an air brake or an electric/mechanical stopper such as a shock absorber to reduce the shock of moving parts. (No linear servo motor with an electromagnetic brake is available.)
- The magnetic attraction force acting between the primary side and the secondary is always acting even when the linear servo motor power is not turned on. Because of this, the machine must be designed to be rigid enough to resist the magnetic attraction force and maintain the accuracy.
- The running load by friction increases in proportion to the increase of the magnetic attraction force, so the design must be made to decrease as much friction as possible, for example, by mounting guides with high accuracy.
- Do not use for vertical motion applications since magnetic poles cannot be detected with a vertical application.
- Install the linear servo motor the way in which the thrust acts on the gravity center of the moving part. When the thrust does not act on the gravity center of the moving part, the moment is generated.
- Magnetic chips such as iron fragments can be attached to the permanent magnet on the secondary side, which may cause a malfunction. In the environment like this, take measures against the attachment and entry of magnetic chips.
- When the linear servo motor is operated over a long term under the condition where water for cutting, lubrication oil, etc. is splashed or where dew condensation occurs due to oil mist, supercooling, or high humidity, insulation deterioration, etc. may be caused. Protect the linear servo motor from oil and dust with a cover and take measures against dew condensation.
- More careful measures against oil and dust must be taken for the linear encoder than the linear servo motor. For details, contact each linear encoder manufacturer.
- The moving direction of the linear servo motor and linear encoder must be matched. Otherwise, the linear servo motor may operate unexpectedly.
- Keep the cumulative pitch error of the mounting screw holes within  $\pm 0.2$  mm (0.1 mm for LM-K2 series). When two or more secondary sides are mounted, clearance may be left between the secondary sides depending on the mounting method and the numbers.
- Do not strike the connector. Otherwise, a connection failure, malfunction, etc. may occur.
- Do not hit the primary side on the stopper. The primary side may be damaged. Design the machine so that the stopper is hit on the table attached to the primary side.
- Screw holes of the linear servo motor are for machine installation. Do not use for other purposes.
- Do not touch the linear servo motor with wet hands.
- For installation, use all the screw holes prepared on the linear servo motor.
- When the product has been stored for an extended period of time, contact your local sales office.
- When treating the linear servo motor, be careful about the edged parts such as the corners of the linear servo motor.
- To prevent a fire or injury from occurring in case of an earthquake or other natural disasters, securely install, mount, and wire the servo motor in accordance with the Instruction Manual.

## ⚠ CAUTION

- When you keep or use the equipment, please fulfill the following environment.

Item		Environment
Ambient temperature	Operation	0 °C to 40 °C (non-freezing)
	Storage	-15 °C to 70 °C (non-freezing)
Ambient humidity	Operation	10 %RH to 80 %RH (non-condensing)
	Storage	10 %RH to 90 %RH (non-condensing)
Ambience		Indoors (no direct sunlight), free from corrosive gas, flammable gas, oil mist, dust, and dirt
Altitude		1000 m or less above sea level
Vibration resistance	LM-H3 series	49 m/s <sup>2</sup>
	LM-U2 series	
	LM-F series	
	LM-K2 series	

### (2) Wiring

## ⚠ CAUTION

- Wire the equipment correctly and securely. Otherwise, the linear servo motor may operate unexpectedly.
- Make sure to connect the cables and connectors by using the fixing screws and the locking mechanism. Otherwise, the cables and connectors may be disconnected during operation.
- Do not install a power capacitor, surge killer, or radio noise filter (FR-BIF(-H) option) on the servo amplifier output side.
- Connect the servo amplifier power output (U/V/W) to the linear servo motor power input (U/V/W) correctly. Otherwise, the linear servo motor does not operate properly.
- Connect the servo amplifier power output (U/V/W) to the linear servo motor power input (U/V/W) directly. Do not let a magnetic contactor, etc. intervene. Otherwise, it may cause a malfunction.

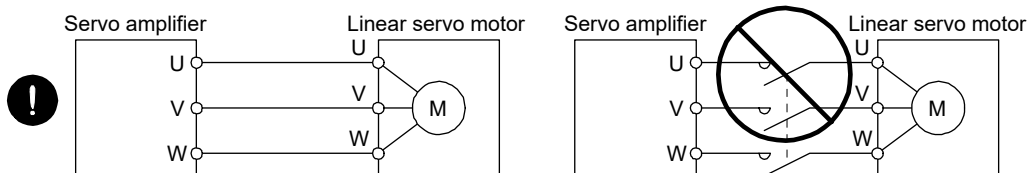

- Do not connect AC power directly to the linear servo motor. Otherwise, it may cause a malfunction.
- When the cable is not tightened enough to the terminal block, the cable or terminal block may generate heat because of the poor contact. Be sure to tighten the cable with specified torque.
- The cables such as power cables deriving from the primary side cannot stand the long-term flexing action. Avoid the flexing action by fixing them to the moving part, etc. Also, use the cable that stands the long-term flexing action for the wiring to the servo amplifier.

### (3) Test run and adjustment

## ⚠ CAUTION

- Before operation, check the parameter settings. Improper settings may cause some machines to perform unexpected operation.
- Never change the adjustment extremely as it will make operation unstable.

#### (4) Usage

### CAUTION

- For equipment in which the moving part of the machine may collide against the load side, install a limit switch or stopper to the end of the moving part. The machine may be damaged due to a collision.
- Provide an external emergency stop circuit to ensure that operation can be stopped and power switched off immediately.
- Do not disassemble, repair, or modify the product. Otherwise, an electric shock, fire, injury, etc. may occur. Disassembled, repaired, and/or modified products are not covered under warranty.
- Use the servo amplifier with the specified linear servo motor.
- If the dynamic brake is activated at power-off, alarm occurrence, etc., do not drive the primary side of the linear servo motor by an external force. Doing so may cause a fire.
- Correctly wire options and peripheral equipment, etc. in the correct combination. Otherwise, an electric shock, fire, injury, etc. may occur.

#### (5) Corrective actions

### CAUTION

- When it is assumed that a hazardous condition may occur due to a power failure or product malfunction, use a servo motor with an external brake to prevent the condition.
- When any alarm has occurred, eliminate its cause, ensure safety, and deactivate the alarm before restarting operation.
- Provide an adequate protection to prevent unexpected restart after an instantaneous power failure.
- To prevent an electric shock, injury, or fire from occurring after an earthquake or other natural disasters, ensure safety by checking conditions, such as the installation, mounting, wiring, and equipment before switching the power on.

#### (6) Maintenance, inspection and parts replacement

### CAUTION

- When the linear servo motor is damaged, it must be replaced.

#### (7) Storage of linear servo motor

### CAUTION

Note the followings when storing the linear servo motor for an extended period of time (guideline: three or more months).

- Always store the servo motor indoors in a clean and dry place.
- If it is stored in a dusty or damp place, make adequate provision, e.g. cover the whole product.
- Though the servo motor is rust-proofed before shipment using paint or rust prevention oil, rust may be produced depending on the storage conditions or storage period.  
If the servo motor is to be stored for longer than six months, apply rust prevention oil again especially to the machined surfaces.
- When the product has been stored for an extended period of time, contact your local sales office.

## (8) Disposal

### WARNING

- The linear servo motor contains a strong magnet on the secondary side. Therefore, not only the operators but also the people around the workplace must use abundance of caution when the linear servo motor is disassembled or discarded. For example, one who uses a medical device like a pacemaker must keep away from the machine.
- The permanent magnet on the secondary side makes the magnetic bodies (including the primary side and the other secondary sides) generate attraction force. Be careful not to get your hand stuck when the linear servo motor is disassembled or discarded. Use special caution with the handling of the secondary side which is demagnetized before/after disassembly.
- When the linear servo motor is disassembled or discarded, do not put magnetic bodies (including the primary side, the other secondary sides and tools) close to the secondary side. The magnet face side of secondary side has strong magnetic attraction force, which may cause a serious injury. In all cases, to avoid any injury, be cautious in the workplace and around it.
- An attraction force is generated when magnetic bodies (including tools) are put near the permanent magnet on the secondary side. Be sure to use nonmagnetic tools for the disassembly and disposal of the linear servo motor or the work around it. These are required for the improvement of workability and safety ensuring.
- The personnel who work for the disassembly or disposal of the linear servo motor or those who are around the workplace must not work wearing electronic devices (watch, calculator, personal computer, etc.) and magnetic recording media (IC card, magnetic card, floppy disc, etc.) and must not bring them around a magnetic. The magnetic influence may cause the operation failure or malfunction.
- The servo amplifier and the primary side of the linear servo motor must be discarded in accordance with "DISPOSAL OF WASTE".
- Since the secondary side of the linear servo motor uses the permanent magnet, demagnetize the entire secondary side by heating over 300 °C, then discard in accordance with "DISPOSAL OF WASTE".
- Do not touch the secondary side after the demagnetization of the secondary side by heating over 300 °C until it becomes cool enough. Otherwise, you may get burnt.

## (9) General instruction

- To illustrate details, the equipment in the diagrams of this Instruction Manual may have been drawn without covers and safety guards. When the equipment is operated, the covers and safety guards must be installed as specified. Operation must be performed in accordance with this Instruction Manual.

### ● DISPOSAL OF WASTE ●

Please dispose a linear servo motor and other options according to your local laws and regulations.

# ● HANDLING OF LINEAR SERVO MOTOR ●

## 1. Structure of linear servo motor

Linear servo motor has the primary side which consists of the iron core and coil, and the secondary side which consists of the mounting part (yoke) and permanent magnet. (excluding coreless type LM-U2P\_)

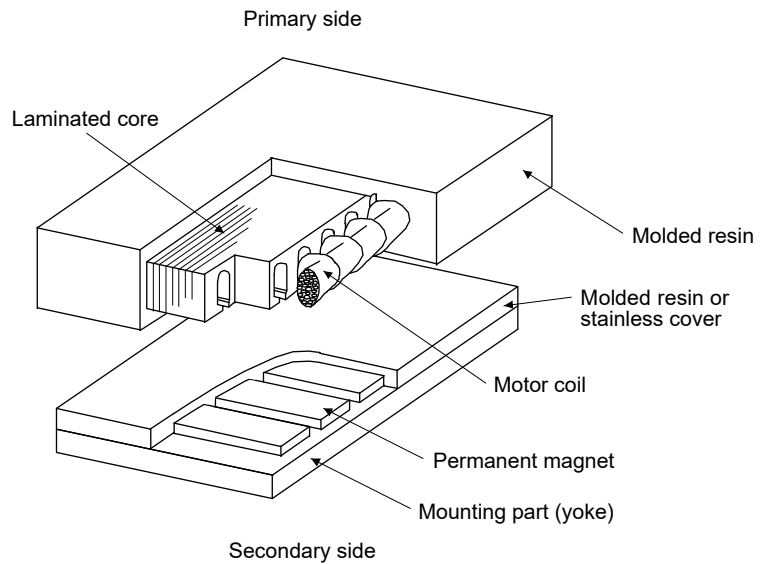

### (a) Primary side

The primary side has the motor core with winding and is covered with the molded resin.

### (b) Secondary side

The secondary side has the permanent magnet on the mounting part (yoke) and is covered with the molded resin or stainless cover.

## 2. Magnetic attraction force

The secondary side of the linear servo motor contains a strong permanent magnet, so a magnetic attraction force (the force by which a magnet attracts magnetic bodies) is generated toward magnetic bodies such as iron.

This magnetic attraction force is always acting regardless of linear motor power on/off.

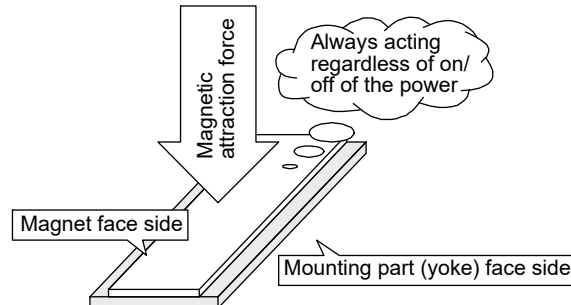

The magnetic fluxes generating from the permanent magnet disperse in the air from the magnet face side (facing the primary side), and most of them do not leak to the mounting part (yoke) surface side for its structure.

Because of this, a magnetic attraction force occurs on the magnet face side of the secondary side, not on the mounting part (yoke) surface side.

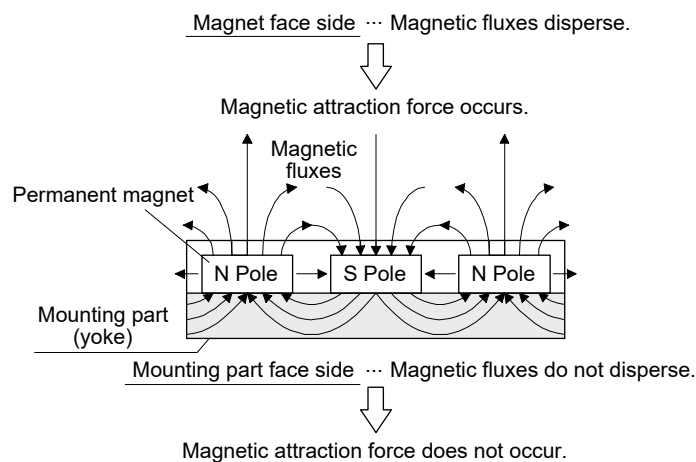

The permanent magnet used for the linear servo motor is very strong.

When an A4-sized iron sheet is fully attracted, the magnetic attraction force becomes as high as 2.5 t. Use abundance of caution with the handling.

When an A4-sized iron sheet is fully attracted ...

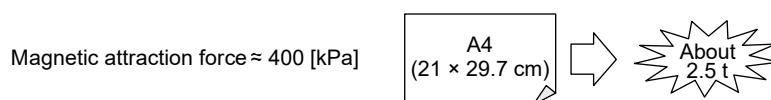

## 3. For the safety

The magnetic attraction force is in inverse proportion to square of the distance to a magnetic body, so it drastically increases when the distance becomes small.

When mounting the secondary side of linear side motor, ensure the sufficient distance from the magnetic bodies around it and securely fix those magnetic bodies.

#### 4. Notes on handling

- (1) Handling must be done by the engineers who have a full knowledge of this product.
- (2) One who uses a medical device like a pacemaker must keep away from the product and equipment.
- (3) Do not wear metals such as watch, pierced earring, necklace, etc.
- (4) Use nonmagnetic tools.  
(Example) Explosion-proof beryllium copper alloy safety tools: bealon (NGK)
- (5) Do not put magnetic card, watch, portable phone, etc. close to the motor.
- (6) Do not add a shock or a stress on the mold part of the product. (Otherwise, the linear servo motor may be damaged.)
- (7) Display "Note a strong magnetic." or the like and take action by giving cautions to the surrounding, etc.

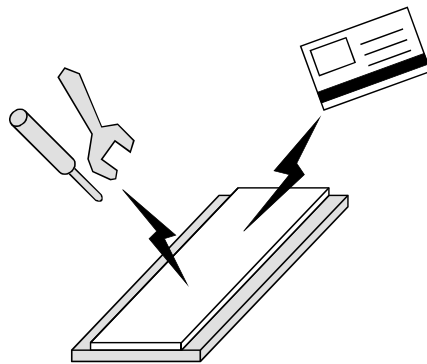

#### 5. Disposal of linear servo motor

- (1) The primary side must be discarded as industrial waste.
- (2) The secondary side must be discarded as industrial waste after demagnetization over 300 °C.
- (3) Do not leave the product.

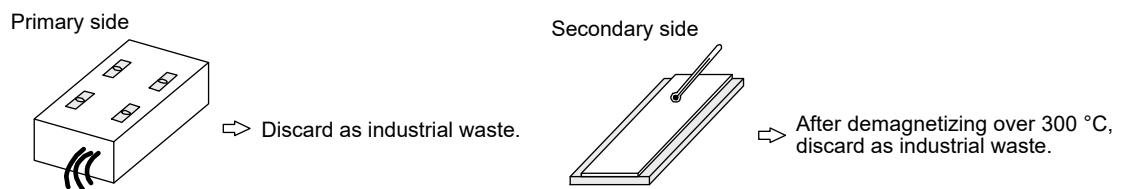

#### «Wiring»

Wires mentioned in this Instruction Manual are selected based on the ambient temperature of 40 °C.

«U.S. customary unit»

U.S. customary units are not shown in this manual. Convert the values if necessary according to the following table.

Quantity	SI (metric) unit	U.S. customary unit
Mass	1 [kg]	2.2046 [lb]
Length	1 [mm]	0.03937 [inch]
Torque	1 [N•m]	141.6 [oz•inch]
Moment of inertia	1 [( $\times 10^{-4}$ kg•m <sup>2</sup> )]	5.4675 [oz•inch <sup>2</sup> ]
Load (thrust load/axial load)	1 [N]	0.2248 [lbf]
Temperature	N [ $^{\circ}$ C] $\times$ 9/5 + 32	N [ $^{\circ}$ F]



## CONTENTS

<b>1. HANDLING OF LINEAR SERVO MOTOR</b>	<b>1- 1 to 1-10</b>
1.1 General instructions.....	1- 1
1.2 Instructions on design.....	1- 2
1.3 Instructions on installation operation .....	1- 5
1.4 Instructions on storage .....	1- 8
1.5 Instructions for discarding.....	1- 9
<b>2. INSPECTION</b>	<b>2- 1 to 2- 2</b>
2.1 Inspections on primary side (coil).....	2- 1
2.2 Inspections on secondary side (magnet).....	2- 2
2.3 Inspections of linear encoder.....	2- 2
<b>3. REPLACEMENT OF LINEAR SERVO MOTOR ON ABSOLUTE POSITION DETECTION SYSTEM</b>	<b>3- 1 to 3- 2</b>
3.1 Replacement of primary side (coil) or secondary side (magnet).....	3- 1
3.2 Replacement of linear encoder.....	3- 1
<b>4. CONNECTION OF SERVO AMPLIFIER AND LINEAR SERVO MOTOR</b>	<b>4- 1 to 4-10</b>
4.1 Connection instructions .....	4- 2
4.2 Power supply cable wiring diagrams .....	4- 2
4.2.1 LM-H3/LM-U2/LM-K2 series .....	4- 2
4.2.2 LM-F series .....	4- 4
4.3 Selection example of wires.....	4- 5
4.4 Servo amplifier terminal section.....	4- 7
<b>5. LINEAR SERVO MOTOR</b>	<b>5- 1 to 5-76</b>
5.1 Rating plate.....	5- 1
5.2 LM-H3 series.....	5- 3
5.2.1 Model definition .....	5- 3
5.2.2 Combinations of servo amplifiers and linear servo motors.....	5- 4
5.2.3 LM-H3 series specification list .....	5- 5
5.2.4 Thrust characteristics .....	5- 6
5.2.5 Installation .....	5- 8
5.2.6 Dimensions.....	5-11
5.3 LM-U2 series.....	5-17
5.3.1 Model definition .....	5-17
5.3.2 Combinations of servo amplifiers and linear servo motors.....	5-19
5.3.3 LM-U2 series specification list .....	5-20
5.3.4 Thrust characteristics .....	5-22
5.3.5 Installation .....	5-24
5.3.6 Dimensions.....	5-27
5.4 LM-F series.....	5-40
5.4.1 Model definition .....	5-40
5.4.2 Combinations of servo amplifiers/drive units and linear servo motors .....	5-41
5.4.3 LM-F series specification list.....	5-42

5.4.4 Thrust characteristics .....	5-43
5.4.5 Installation .....	5-44
5.4.6 Liquid cooling .....	5-47
5.4.7 Dimensions.....	5-48
5.5 LM-K2 series.....	5-58
5.5.1 Model definition .....	5-58
5.5.2 Combinations of servo amplifiers and linear servo motors .....	5-59
5.5.3 LM-K2 series specification list.....	5-60
5.5.4 Thrust characteristics .....	5-61
5.5.5 Installation .....	5-62
5.5.6 Dimensions.....	5-66

APPENDIX	App.- 1 to App.- 7
----------	--------------------

App. 1 Capacity selection of linear servo motor .....	App.- 1
App. 2 Wiring option .....	App.- 7
App. 3 Manufacturer list.....	App.- 7

# 1. HANDLING OF LINEAR SERVO MOTOR

---

## 1. HANDLING OF LINEAR SERVO MOTOR

The secondary side of the linear servo motor contains a strong permanent magnet. The wrong handling may cause serious accidents, which is extremely dangerous. Please read this chapter carefully beforehand and use it correctly.

### 1.1 General instructions

 <b>WARNING</b>	<ul style="list-style-type: none"><li>● The linear servo motor contains a strong magnet on the secondary side. Therefore, not only the linear servo motor installation operators but also the machine operators must use abundance of caution. For example, one who uses a medical device like a pacemaker must keep away from the machine.</li><li>● The permanent magnet on the secondary side makes the magnetic bodies generate attraction force. Be careful not to get your hand stuck.</li><li>● The performance is not guaranteed if the specified servo amplifier and linear servo motor are not combined. If used with unspecified combination, the servo amplifier or linear servo motor may be damaged. Depending on the case, it can be out of control and operate unexpectedly, resulting in extremely dangerous condition.</li></ul>
--	--

 <b>CAUTION</b>	<ul style="list-style-type: none"><li>● The linear servo motor installation operators and machine operators must not work wearing electronic devices (watch, calculator, personal computer, etc.) and magnetic recording media (IC card, magnetic card, floppy disc, etc.) and must not bring them around a magnetic. The magnetic influence may cause the operation failure or malfunction.</li><li>● The IP rating of the linear servo motor is IP00. Take necessary measures against dust, oil, etc. (Refer to section 1.2 Instructions on design.)</li><li>● When the linear servo motor is damaged, it must be replaced.</li><li>● The servo amplifier heat sink, regenerative resistor, linear servo motor, etc. may be hot while power is on or for some time after power-off. Take safety measures, e.g. provide covers, to prevent accidental contact of hands and parts (cables, etc.) with them.</li><li>● The primary side and secondary side may be damaged by a fall or shock.</li></ul>
--	--

# 1. HANDLING OF LINEAR SERVO MOTOR

---

## 1.2 Instructions on design

### CAUTION

- The dynamic brake can be applied by the servo amplifier, but the coasting distance becomes longer when the moving body is heavy or when the speed is high. It may result in crashing into the stroke end, which is highly dangerous. Install the anticrash mechanism such as an air brake or an electric/mechanical stopper such as a shock absorber to reduce the shock of moving parts. (No linear servo motor with an electromagnetic brake is available.)
- The magnetic attraction force acting between the primary side and the secondary is always acting even when the linear servo motor power is not turned on. Because of this, the machine must be designed to be rigid enough to resist the magnetic attraction force and maintain the accuracy.
- The running load by friction increases in proportion to the increase of the magnetic attraction force, so the design must be made to decrease as much friction as possible, for example, by mounting guides with high accuracy.
- Do not use for vertical motion applications since magnetic poles cannot be detected with a vertical application.
- Install the linear servo motor the way in which the thrust acts on the gravity center of the moving part. When the thrust does not act on the gravity center of the moving part, the moment is generated.
- Design the primary side and secondary side to satisfy the mounting dimensions.
- The cables such as power cables deriving from the primary side cannot stand the long-term flexing action. Avoid the flexing action by fixing them to the moving part, etc. Also, use the cable that stands the long-term flexing action for the wiring to the servo amplifier.
- Magnetic chips such as iron fragments can be attached to the permanent magnet on the secondary side, which may cause a malfunction. In the environment like this, take measures against the attachment and entry of magnetic chips.
- When the linear servo motor is operated over a long term under the condition where water for cutting, lubrication oil, etc. is splashed or where dew condensation occurs due to oil mist, supercooling, or high humidity, insulation deterioration, etc. may be caused. Protect the linear servo motor from oil and dust with a cover and take measures against dew condensation.
- When using linear guide as base, check the specifications of the linear guide, and determine the machining accuracy. For details, please contact each linear guide manufacturer.
- More careful measures against oil and dust must be taken for the linear encoder than the linear servo motor. For details, please contact each linear encoder manufacturer.
- The moving direction of the linear servo motor and linear encoder must be matched. Otherwise, the linear servo motor may operate unexpectedly.
- Movable range of linear servo motor should be equal to or less than the linear encoder effective measurement length.
- Keep the cumulative pitch error of the mounting screw holes within  $\pm 0.2$  mm (0.1 mm for LM-K2 series). When two or more secondary sides are mounted, clearance may be left between the secondary sides depending on the mounting method and the numbers.
- Do not hit the primary side on the stopper. The primary side may be damaged. Design the machine so that the stopper is hit on the top table attached to the primary side.
- For the stopper, use shock-absorbing material such as polyurethane rubber.

# 1. HANDLING OF LINEAR SERVO MOTOR

POINT
●To execute the high-accuracy positioning, ensure as much rigidity of machine as possible, and make the machine resonance point higher.
●To ensure as much rigidity of machine as possible, adopt an integrated structure to the base. When using bolts, etc. as fastener is inevitable, use the thick bolt whose under head height is short. Make the pitch dimension of bolt holes as small as possible.
●Make the moving parts as light as possible, and make the base parts heavier and sturdier.
●When mounting a work, etc. on the table, make the gravity center as low as possible. Additionally, the gravity center should be between the two linear guides.
●As the operation and the accuracy of machine may be negatively affected, design the thrust center of linear servo motor to be close to the gravity center of the moving body.
●When the mounting rigidity of the linear encoder is not enough, the feedback signal may be disturbed by the machine vibration, etc., and the desired performance may not be satisfied. As it is also the same case when the linear encoder is susceptible to electrical noise, set up and mount the linear encoder in the position where it is affected by as little vibration and electrical noise as possible.
●Establish the structure durable against high speed and high acceleration and deceleration.

## (1) Basic structure of linear servo motor incorporated slider

The following diagram shows the basic structure of linear slider.

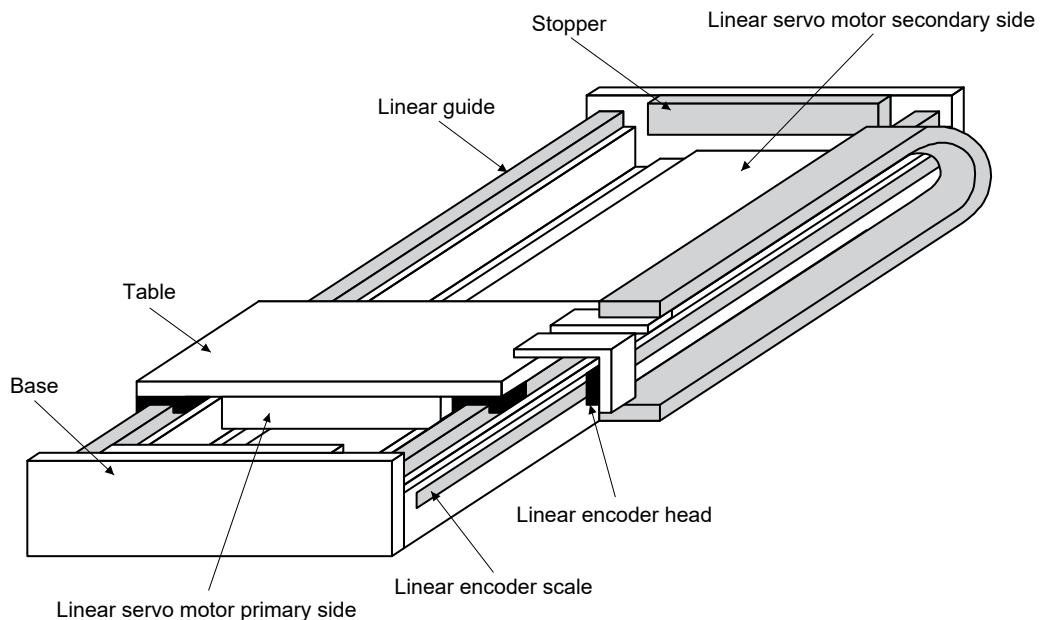

# 1. HANDLING OF LINEAR SERVO MOTOR

## (2) Instructions on the structure of linear slider

The following diagram shows the instructions on the structure of linear slider.

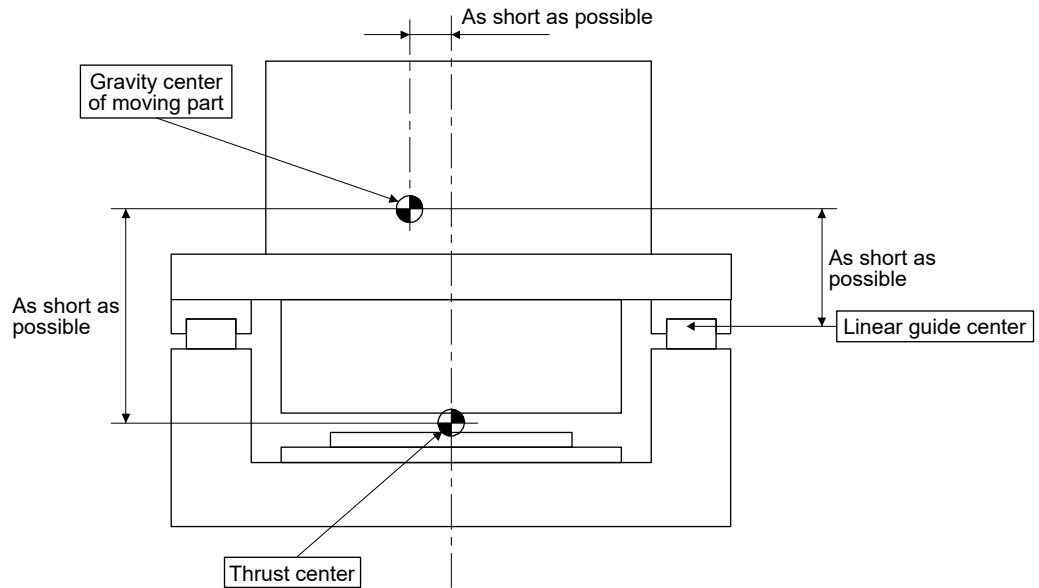

## (3) Stopper

Design the machine so that the stopper is hit on the top table attached to the primary side as shown in the following diagram.

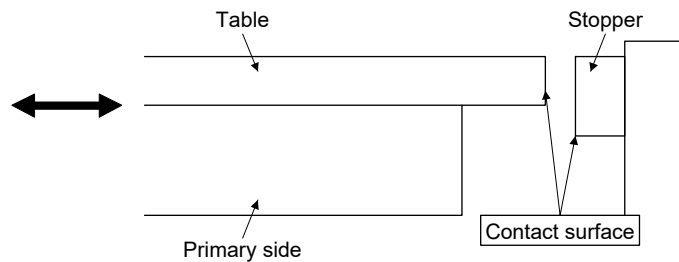

## (4) Linear encoder

More careful measures against oil and dust must be taken for the linear encoder than the linear servo motor.

For details, contact each linear encoder manufacturer.

## (5) Linear guide

Mount the linear guide with high accuracy.

For details, please contact each linear guide manufacturer.

# 1. HANDLING OF LINEAR SERVO MOTOR

## 1.3 Instructions on installation operation

- Under the packaged condition (cardboard) delivered from our company, the magnet on the secondary side does not have a serious effect on the outside. Before mounting to the machine, however, magnetic bodies (including tools) must be kept away from the secondary side. The magnet face side of secondary side has strong magnetic attraction force, which may cause a serious injury. To avoid any injury, be cautious in the workplace and around it.

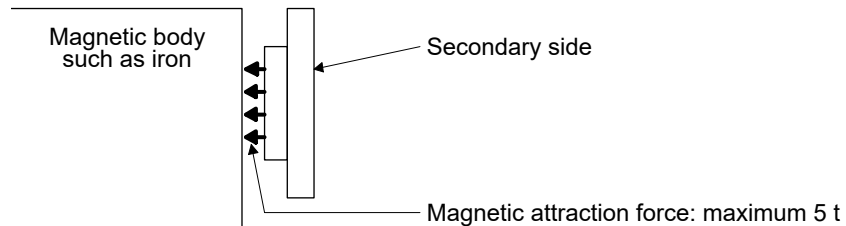

### ⚠ WARNING

- The permanent magnet on the secondary side makes the magnetic bodies generate attraction force, which may cause an accident such as getting hands stuck, etc. For the installation of the linear servo motor and the work around it, be sure to use nonmagnetic tools ((example) explosion-proof beryllium copper alloy safety tools: bealon (manufactured by NGK)). These are required for the improvement of workability and safety ensuring. Use special caution when mounting the primary side after mounting the secondary side. For screws to use, refer to dimensions of each linear servo motor series.
- To prevent electric shock, ground each equipment securely.

### ⚠ CAUTION

- Install the servo amplifier, servo motor, and regenerative resistor on incombustible material. Installing them directly or close to combustibles will lead to a fire or smoke generation.
- Securely fix the linear servo motor to the machine. If being fixed insecurely, the linear servo motor may come off during operation, leading to injury.
- Install the servo amplifier and the linear servo motor in a load-bearing place in accordance with the Instruction Manual.
- Do not drop or strike the servo amplifier and the linear servo motor. Isolate them from all impact loads.
- Do not install or operate the servo amplifier and the linear servo motor which have been damaged or have any parts missing.
- Use the equipment within the specified environment. (For the environment, refer to the specifications of each linear servo motor series.)
- Screw holes on the linear servo motor are for machine installation. Do not use for other purposes.
- Do not touch the linear servo motor with wet hands.
- For installation, use all the screw holes prepared on the linear servo motor.
- Keep the cumulative pitch error of the mounting screw holes within  $\pm 0.2$  mm (0.1 mm for LM-K2 series). When two or more secondary sides are mounted, clearance may be left between the secondary sides depending on the mounting method and the number of secondary sides.

# 1. HANDLING OF LINEAR SERVO MOTOR

Instructions when installing the linear servo motor using lifting machines such as crane are shown below.

## (1) Primary side (coil)

For lifting the primary side, lift the tool for lifting attached to the primary side or lift the eyebolt attached to the screw hole for primary-side mounting as shown in the following diagram.

When lifting, be careful not to add any stress on the mold part and the power cable by the wire, etc. Set the lifting points on both longitudinal ends (two or more).

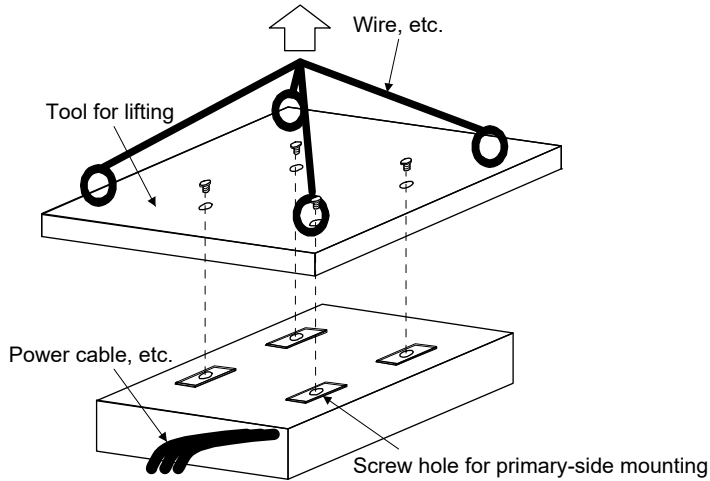

When using the tool for lifting

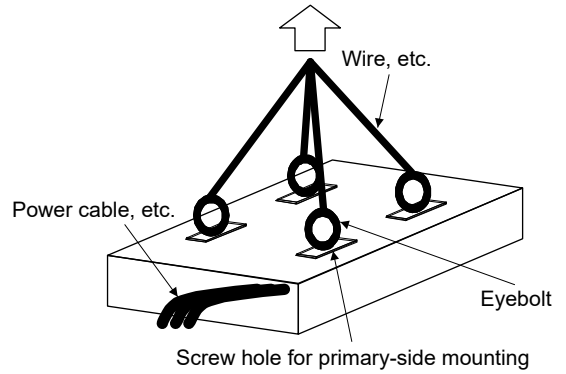

When using the eyebolt

# 1. HANDLING OF LINEAR SERVO MOTOR

## (2) Secondary side (magnet)

Lift the secondary side with the eyebolt attached to the screw hole for secondary-side mounting as shown in the following diagram.

When lifting the secondary side, to avoid the danger due to the magnetic attraction force, be sure to make the magnet face side upward, and set the lifting points in four or more points.

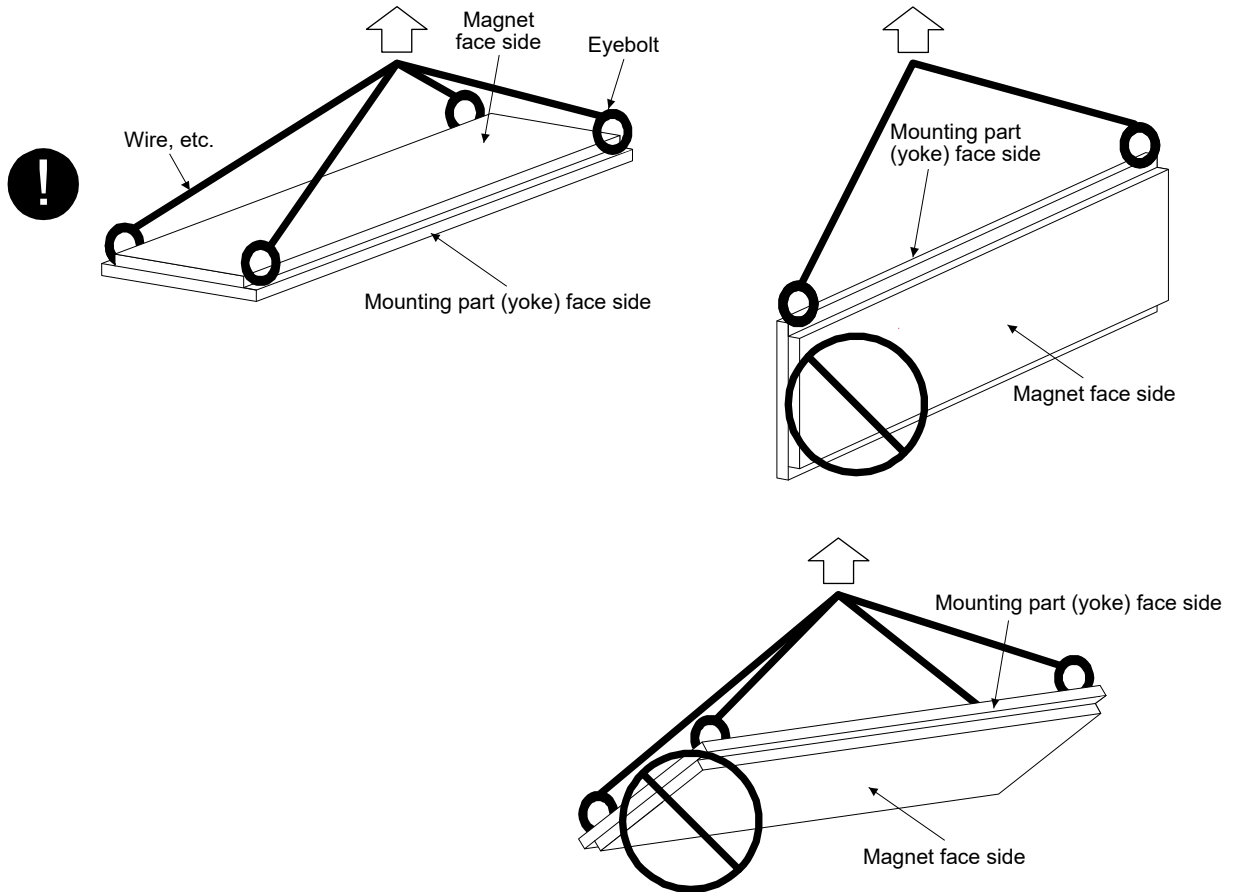

# 1. HANDLING OF LINEAR SERVO MOTOR

## 1.4 Instructions on storage



**CAUTION**

- Do not get on or put heavy load on the equipment. Otherwise, it may cause injury.
- Be sure to follow the storage conditions (ambient temperature and humidity, etc.).
- Store the product in the environment where the rain water is prevented from splashing on and dust, oil, and chemical materials from attaching on.
- Do not strike servo amplifier or linear servo motor.
- Do not modify the linear servo motor.
- Note the followings when storing the linear servo motor for an extended period of time (guideline: three or more months).
  - Always store the servo motor indoors in a clean and dry place.
  - If it is stored in a dusty or damp place, make adequate provision, e.g. cover the whole product.
  - Though the servo motor is rust-proofed before shipment using paint or rust prevention oil, rust may be produced depending on the storage conditions or storage period.  
If the servo motor is to be stored for longer than six months, apply rust prevention oil again especially to the machined surfaces.
- When the product has been stored for an extended period of time, contact your local sales office.

(1) Correctly store the linear servo motor in the package.

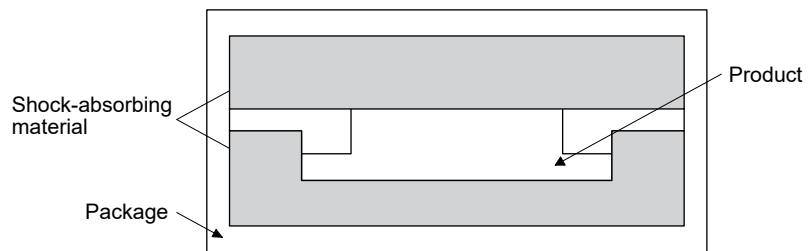

(2) When storing the secondary side, put a display such as "Note a strong magnetic." on the package or storage rack, and take action by giving cautions to the surrounding, etc.

(3) Do not use the deformed package.

(4) Store the equipment under the following environment.

Item	Environment
Ambient temperature	-15 °C to 70 °C (non-freezing)
Ambient humidity	10 %RH to 90 %RH (non-condensing)
Ambience	Indoors (no direct sunlight), free from corrosive gas, flammable gas, oil mist, dust, and dirt
Vibration resistance	49 m/s <sup>2</sup>

(5) When lifting the product using a tool for lifting, be careful not to add any impact and stress on the mold part.

# 1. HANDLING OF LINEAR SERVO MOTOR

## 1.5 Instructions for discarding

Demagnetize the secondary side of the linear servo motor by heating over 300 °C, then discard it in accordance with Law for Promotion of Effective Utilization of Resources.

**⚠ WARNING**

- The linear servo motor contains a strong magnet on the secondary side. Therefore, not only the operators but also the people around the workplace must use abundance of caution when the linear servo motor is disassembled or discarded. For example, one who uses a medical device like a pacemaker must keep away from the machine.
- The permanent magnet on the secondary side makes the magnetic bodies (including the primary side and the other secondary sides) generate attraction force. Be careful not to get your hand stuck when the linear servo motor is disassembled or discarded. Use special caution with the handling of the secondary side which is demagnetized before/after disassembly.
- When the linear servo motor is disassembled or discarded, do not put magnetic bodies (including the primary side, the other secondary sides and tools) close to the secondary side. The magnet face side of secondary side has strong magnetic attraction force, which may cause a serious injury. In all cases, to avoid any injury, be cautious in the workplace and around it.

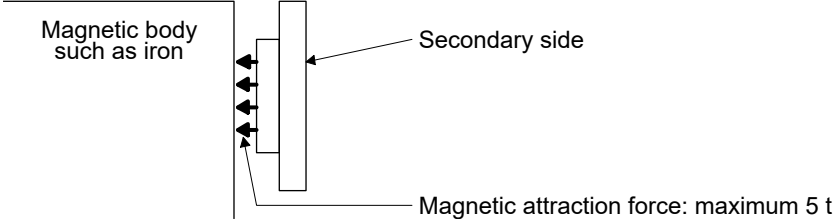

The diagram illustrates the magnetic attraction force. On the left, a vertical bar represents a 'Magnetic body such as iron'. On the right, a vertical bar represents the 'Secondary side'. Four arrows point from the magnetic body towards the secondary side, indicating the direction of the magnetic attraction force. A label at the bottom right of the diagram states 'Magnetic attraction force: maximum 5 t'.

- An attraction force is generated when magnetic bodies (including tools) are put near the permanent magnet on the secondary side. Be sure to use nonmagnetic tools for the disassembly and disposal of the linear servo motor or the work around it. These are required for the improvement of workability and safety ensuring.

**⚠ CAUTION**

- The linear servo motor installation operators and machine operators must not work wearing electronic devices (watch, calculator, personal computer, etc.) and magnetic recording media (IC card, magnetic card, floppy disc, etc.) and must not bring them around a magnetic. The magnetic influence may cause the operation failure or malfunction.
- Be careful not to get your hand stuck when the linear servo motor is disassembled or discarded.
- Do not touch the secondary side after the demagnetization of the secondary side by heating over 300 °C until it becomes cool enough. Otherwise, you may get burnt.



## 2. INSPECTION

---

### 2. INSPECTION

#### WARNING

- Before starting maintenance and/or inspection, turn off the power and wait for 15 minutes or more until the charge lamp turns off. Then, confirm that the voltage between P+ and N- is safe with a voltage tester and others. Otherwise, an electric shock may occur. In addition, when confirming whether the charge lamp is off or not, always confirm it from the front of the servo amplifier.
- To avoid an electric shock, only qualified personnel should attempt inspections. For repair and parts replacement, contact your local sales office.

#### CAUTION

- Do not perform insulation resistance test on the linear servo motor. Otherwise, it may cause a malfunction.
- Do not disassemble and/or repair the equipment on customer side.
- The molded resin of the linear servo motor may lose the color. Though the lost color may not be a cause of malfunction, perform inspections.

#### POINT

- If the magnet protective cover is stainless, it may be deformed or damaged if it is strongly pressed or a magnetic body is attached to it. Note that especially the product end part is easily deformed,

It is not until the linear servo motor is mounted in equipment (built-in) that it has functions as motor. As the IP rating is IP00, it is recommended to inspect and clean the motor periodically.

#### 2.1 Inspections on primary side (coil)

##### (1) Attachment of water and oil

Check that the primary side and secondary side have not got wet with water and oil. When the linear servo motor has got wet, the insulation on the primary side is deteriorated, which may cause a malfunction. Make sure to establish the mechanical structure in which water and oil are not attached to the linear motor.

##### (2) Molded resin

Check for missing or cracks of the molded resin on the primary side. When missing or cracks are found in the molded resin on the primary side, replace the primary side as the insulation deterioration, etc. may cause a malfunction.

##### (3) Scratches of primary-side surface which faces the secondary side (magnet)

Check for scratches on the primary-side surface which faces the secondary side. When the primary-side surface which faces the secondary side has scratches, replace the primary side. When a scratch occurs on the primary side due to a foreign matter caught in the empty clearance between the primary side and the secondary side, take away the matter and establish the mechanical structure where such matters are not caught.

##### (4) Loose mounting screws

Check for loose mounting screws on the primary side. When the mounting screws on the primary side are loose, tighten the corresponding screws.

## 2. INSPECTION

---

(5) Scratches and cracks of linear servo motor cables

Check for scratches and cracks of the linear servo motor cables. If the linear servo motor cables have any scratches or cracks, replace the corresponding cables. Especially when the cables are moved, make inspections periodically.

### 2.2 Inspections on secondary side (magnet)

(1) Attachment of water and oil

Check that the primary side and secondary side have not got wet with water and oil. When the linear servo motor has got wet, the insulation on the primary side is deteriorated, which may cause a malfunction. Make sure to establish the mechanical structure in which water and oil are not attached to the linear motor.

(2) Exposure and lift of magnet

Check for the exposure and lift of the magnet on the secondary side. If the magnet on the secondary side is exposed or lifted, replace the secondary side immediately.

(3) Magnet protective cover

The secondary side surface is covered with the mold resin or stainless cover to protect the magnet.

(a) When a foreign matter such as dust is attached to the surface, wipe away with the acetone-soaked cloth.

(b) Check for missing or cracks of the molded resin on the secondary side. When missing or cracks are found in the molded resin on the secondary side, replace the secondary side.

(c) Check for the scratches of the molded resin on the secondary side. When the magnet is exposed by the scratches of the molded resin on the secondary side, replace the secondary side. When a scratch occurs on the secondary side due to a foreign matter caught in the empty clearance between the primary side and the secondary side, take away the matter and establish the mechanical structure where such matters are not caught.

(4) Loose mounting screws

Check for loose mounting screws on the secondary side. When the mounting screws on the secondary side are loose, tighten the corresponding screws.

### 2.3 Inspections of linear encoder

The inspections of the linear encoder may be required. For the inspections of the linear encoder, contact the linear encoder manufacturer.

### 3. REPLACEMENT OF LINEAR SERVO MOTOR ON ABSOLUTE POSITION DETECTION SYSTEM

### 3. REPLACEMENT OF LINEAR SERVO MOTOR ON ABSOLUTE POSITION DETECTION SYSTEM

#### 3.1 Replacement of primary side (coil) or secondary side (magnet)

After replacing the primary side or the secondary side, perform the magnetic pole detecting operation again.

#### 3.2 Replacement of linear encoder

After replacing the linear encoder, perform the magnetic pole detecting operation again. When replacing the linear encoder, make sure to set a home position by controller.

The following indicates the procedures to check the mounting position.

#### (1) Checking mounting position of linear encoder

- (a) Before replacing the linear encoder, check the encoder information using MR Configurator2 with the linear servo motor fixed at the specified position.
- (b) Replace the linear encoder so that the position gap should be 0.1 mm, comparing before and after the replacement.
- (c) After replacing the linear encoder, check the encoder information using MR Configurator2 again with the linear servo motor fixed at the specified position.
- (d) Check that the value calculated from the difference of the encoder information (resolution unit) before and after the replacement of the linear encoder is under 0.1 mm.

#### (2) Reading encoder information with MR Configurator2

- (a) Select "New" from "Project", and then select "MR-J4-B" from the model and "Linear" from the operation mode.
- (b) Check that the personal computer is connected with the servo amplifier, and select "Diagnosis" and then "Linear diagnosis".

The following window appears.

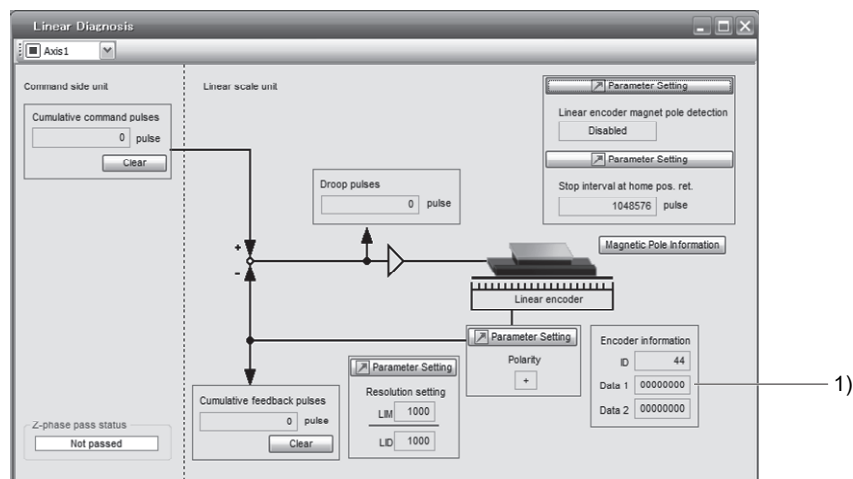

- (c) Data 1) of the encoder information is read.



## 4. CONNECTION OF SERVO AMPLIFIER AND LINEAR SERVO MOTOR

### 4. CONNECTION OF SERVO AMPLIFIER AND LINEAR SERVO MOTOR

#### ! WARNING

- Any person who is involved in wiring should be fully competent to do the work.
- Ground the linear servo motor securely.
- Do not attempt to wire the linear servo motor until it has been installed. Otherwise, it may cause an electric shock.
- The cables should not be damaged, stressed, loaded, or pinched. Otherwise, it may cause an electric shock.
- To avoid an electric shock, insulate the connections of the power supply terminals.

#### ! CAUTION

- Wire the equipment correctly and securely. Otherwise, the linear servo motor may operate unexpectedly, resulting in injury.
- Connect cables to the correct terminals. Otherwise, a burst, damage, etc. may occur.
- Ensure that polarity (+/-) is correct. Otherwise, a burst, damage, etc. may occur.
- Do not install a power capacitor, surge killer or radio noise filter (FR-BIF(-H) option) with the power line of the linear servo motor.
- Do not modify the equipment.
- Connect the servo amplifier power output (U/V/W) to the linear servo motor power input (U/V/W) directly. Do not let a magnetic contactor, etc. intervene. Otherwise, it may cause a malfunction.

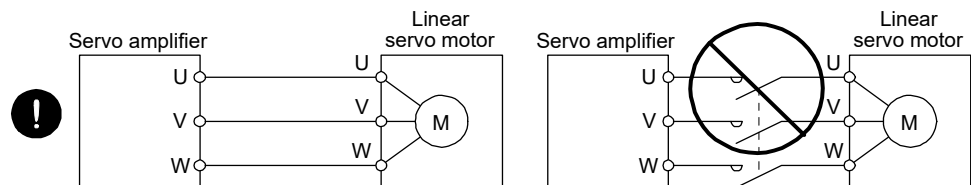

- Before wiring, switch operation, etc., eliminate static electricity. Otherwise, it may cause a malfunction.

#### POINT

- We recommend using HIV wires to connect the servo amplifier to the linear servo motor. Therefore, recommended wire sizes may differ from those of the used wires for the previous linear servo motors.

## 4. CONNECTION OF SERVO AMPLIFIER AND LINEAR SERVO MOTOR

### 4.1 Connection instructions



- To avoid a malfunction, connect the wires to the correct phase terminals (U, V, and W) of the servo amplifier and the linear servo motor.
- Do not connect AC power directly to the linear servo motor. Otherwise, it may cause a malfunction.

Ground the linear servo motor by connecting grounding lead wires between the linear servo motor and the servo amplifier and between the servo amplifier and the protective earth (PE) terminal of the cabinet. Do not connect the wire directly to the protective earth (PE) terminal of the cabinet.

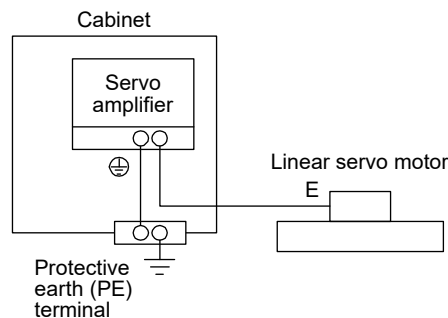

### 4.2 Power supply cable wiring diagrams

#### POINT

- For wiring the power output (U, V, and W) and  $\oplus$  of 5 kW or more servo amplifiers and linear servo motor power input (U, V, and W) and  $\oplus$ , refer to each servo amplifier instruction manual.

Refer to section 4.3 for the wires used for wiring.

#### 4.2.1 LM-H3/LM-U2/LM-K2 series

##### (1) Connection with MR-J4-\_A, MR-J4-\_B, or MR-J4-\_GF servo amplifier

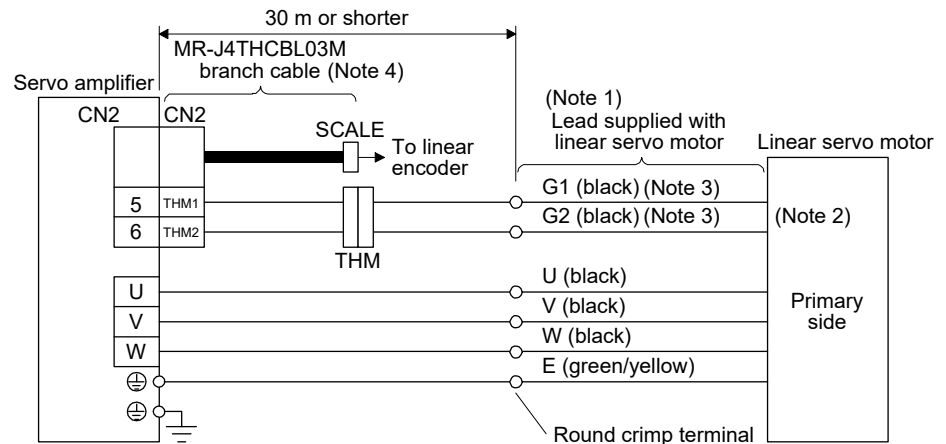

- Note
1. The signal name (U, V, W, E, G1, and G2) is attached on lead wires.
  2. No polarity for the thermistors (G1 and G2).
  3. The color is blue for LM-H3 series.
  4. When not using the branch cable, refer to "Linear Encoder Instruction Manual".

## 4. CONNECTION OF SERVO AMPLIFIER AND LINEAR SERVO MOTOR

### (2) Connection with MR-J4-\_\_A-RJ, MR-J4-\_\_B-RJ, or MR-J4-\_\_GF-RJ servo amplifier

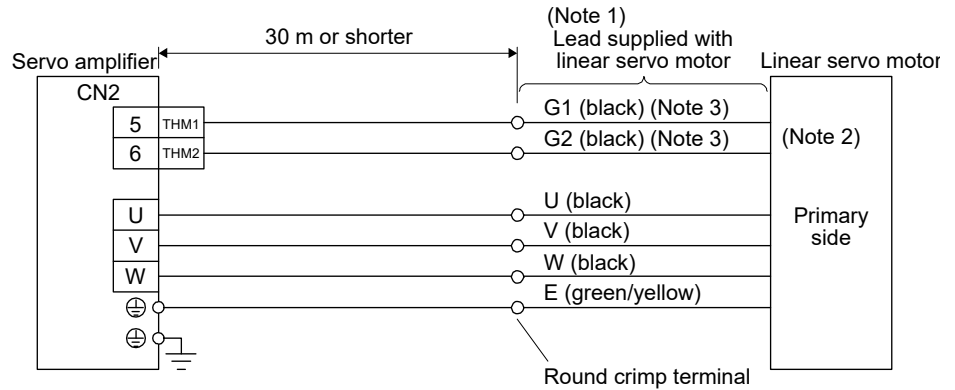

- Note 1. The signal name (U, V, W, E, G1, and G2) is attached on lead wires.  
 Note 2. No polarity for the thermistors (G1 and G2).  
 Note 3. The color is blue for LM-H3 series.

### (3) Connection with MR-J4W-\_\_B servo amplifier

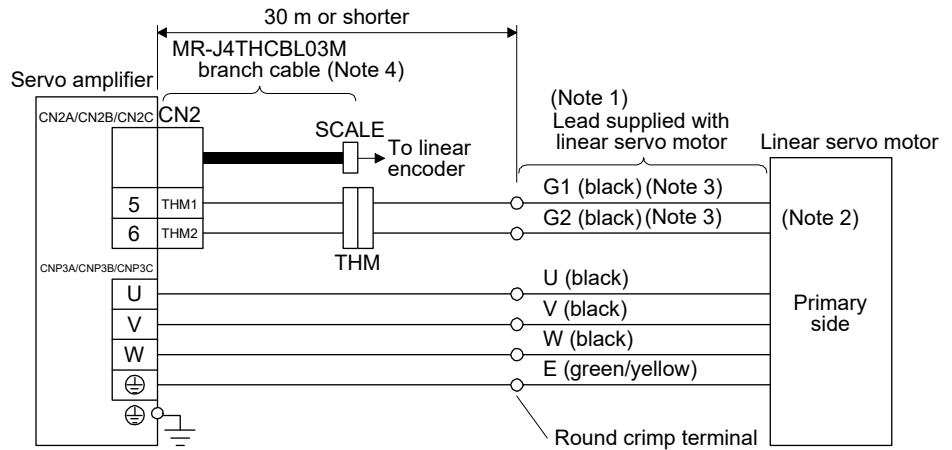

- Note 1. The signal name (U, V, W, E, G1, and G2) is attached on lead wires.  
 Note 2. No polarity for the thermistors (G1 and G2).  
 Note 3. The color is blue for LM-H3 series.  
 Note 4. When not using the branch cable, refer to "Linear Encoder Instruction Manual".

# 4. CONNECTION OF SERVO AMPLIFIER AND LINEAR SERVO MOTOR

## 4.2.2 LM-F series

Junction connector should be prepared by the customer.

### (1) Connection with MR-J4-\_A, MR-J4-\_B, or MR-J4-\_GF servo amplifier

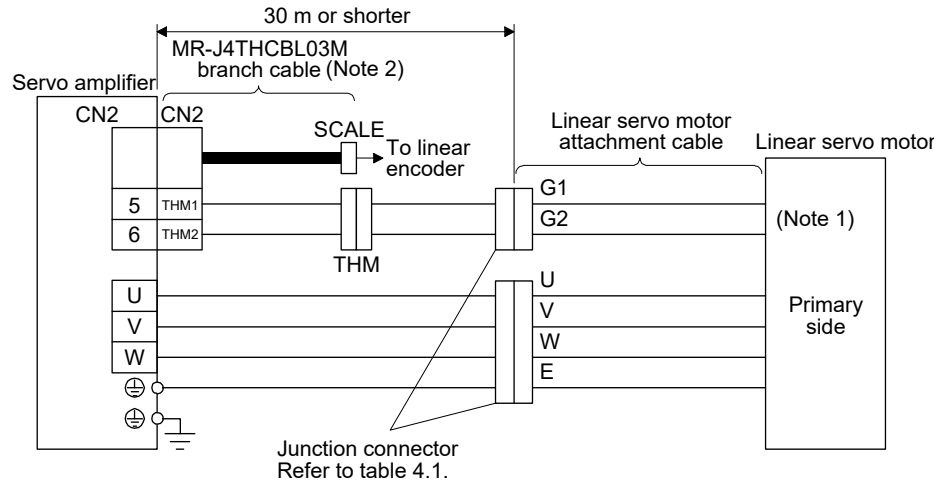

- Note 1. No polarity for the thermistors (G1 and G2).
- 2. When not using the branch cable, refer to "Linear Encoder Instruction Manual".

### (2) Connection with MR-J4-\_A\_-RJ, MR-J4-\_B\_-RJ, or MR-J4-\_GF\_-RJ servo amplifier

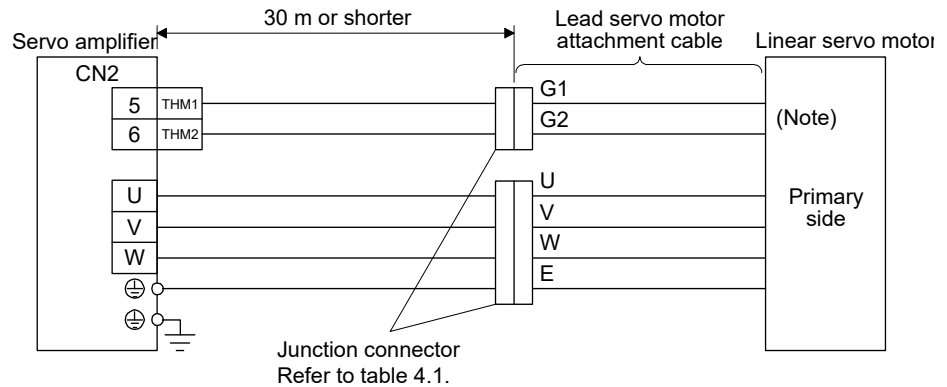

Note. No polarity for the thermistors (G1 and G2).

Table 4.1 Wiring connector

Linear servo motor primary side	Power supply connector	Thermistor connector
LM-FP2B-06M-1SS0	Cable receptacle: D/MS3101A18-10S	Cable receptacle: D/MS3101A14S-9S Cable clamp: D/MS3057-6A (DDK)
LM-FP2D-12M-1SS0	Cable clamp: D/MS3057-10A	
LM-FP2F-18M-1SS0	(DDK)	
LM-FP4B-12M-1SS0	Cable receptacle: D/MS3101A24-22S	Cable receptacle: D/MS3101A14S-9S Cable clamp: D/MS3057-6A (DDK)
LM-FP4D-24M-1SS0	Cable clamp: D/MS3057-16A	
LM-FP4F-36M-1SS0	(DDK)	
LM-FP4H-48M-1SS0		
LM-FP5H-60M-1SS0		

## 4. CONNECTION OF SERVO AMPLIFIER AND LINEAR SERVO MOTOR

### 4.3 Selection example of wires

POINT
<ul style="list-style-type: none"> <li>● Selection condition of wire size is as follows.                             <ul style="list-style-type: none"> <li>Construction condition: Single wire set in midair</li> <li>Wire length: 30 m or less</li> </ul> </li> <li>● Refer to table 4.3 when using LM-F series linear servo motor.</li> </ul>

Selection example of wire size when using HIV wires is indicated below.

Table 4.2 Wire size selection example 1 (HIV wire)

Linear servo motor primary side	Wires [mm <sup>2</sup> ]	
	For power/grounding (U/V/W/E)	For thermistor (G1/G2)
LM-H3P2A-07P-BSS0	1.25 (AWG 16)	0.2 (AWG 24)
LM-H3P3A-12P-CSS0		
LM-H3P3B-24P-CSS0		
LM-H3P3C-36P-CSS0		
LM-H3P3D-48P-CSS0	2 (AWG 14)	
LM-H3P7A-24P-ASS0	1.25 (AWG 16)	
LM-H3P7B-48P-ASS0	2 (AWG 14)	
LM-H3P7C-72P-ASS0	2 (AWG 14)	
LM-H3P7D-96P-ASS0	3.5 (AWG 12)	
LM-U2PAB-05M-0SS0	1.25 (AWG 16)	
LM-U2PAD-10M-0SS0		
LM-U2PAF-15M-0SS0		
LM-U2PBB-07M-1SS0		
LM-U2PBD-15M-1SS0		
LM-U2PBF-22M-1SS0		
LM-U2P2B-40M-2SS0	2 (AWG 14)	
LM-U2P2C-60M-2SS0	3.5 (AWG 12)	
LM-U2P2D-80M-2SS0	5.5 (AWG 10) (Note)	
LM-K2P1A-01M-2SS1	1.25 (AWG 16)	
LM-K2P1C-03M-2SS1	2 (AWG 14)	
LM-K2P2A-02M-1SS1	1.25 (AWG 16)	
LM-K2P2C-07M-1SS1	3.5 (AWG 12)	
LM-K2P2E-12M-1SS1	5.5 (AWG 10) (Note)	
LM-K2P3C-14M-1SS1	3.5 (AWG 12)	
LM-K2P3E-24M-1SS1	5.5 (AWG 10) (Note)	

Note. Refer to each servo amplifier instruction manual for crimp terminals used for connection with the servo amplifier.

## 4. CONNECTION OF SERVO AMPLIFIER AND LINEAR SERVO MOTOR

Table 4.3 Wire size selection example 2 (HIV wire)

LM-F series linear servo motor (primary side)		Wires [mm <sup>2</sup> ]	
		For power/grounding (U/V/W/E)	For thermistor (G1/G2)
LM-FP2B-06M-1SS0	Natural cooling	2 (AWG 14)	0.2 (AWG 24)
	Liquid cooling		
LM-FP2D-12M-1SS0	Natural cooling	2 (AWG 14) (Note 1)	
	Liquid cooling	3.5 (AWG 12) (Note 1)	
LM-FP2F-18M-1SS0	Natural cooling	2 (AWG 14) (Note 1)	
	Liquid cooling	3.5 (AWG 12) (Note 1, 2)	
LM-FP4B-12M-1SS0	Natural cooling	5.5 (AWG 10) (Note 1)	
	Liquid cooling		
LM-FP4D-24M-1SS0	Natural cooling	5.5 (AWG 10) (Note 1)	
	Liquid cooling		
LM-FP4F-36M-1SS0	Natural cooling	5.5 (AWG 10) (Note 1)	
	Liquid cooling	8 (AWG 8) (Note 1, 2)	
LM-FP4H-48M-1SS0	Natural cooling	8 (AWG 8) (Note 1)	
	Liquid cooling	8 (AWG 8) (Note 1, 3)	
LM-FP5H-60M-1SS0	Natural cooling	5.5 (AWG 10) (Note 1)	
	Liquid cooling	8 (AWG 8) (Note 1)	

- Note
1. Refer to each servo amplifier instruction manual for crimp terminals used for connection with the servo amplifier.
  2. Use a wire whose heat-proof temperature is 105 °C or more for wiring to the motor power connector.
  3. Use a wire whose heat-proof temperature is 150 °C or more for wiring to the motor power connector.

## 4. CONNECTION OF SERVO AMPLIFIER AND LINEAR SERVO MOTOR

### 4.4 Servo amplifier terminal section

POINT
<ul style="list-style-type: none"> <li>● For the sizes of wires used for wiring, refer to section 4.3.</li> <li>● When wiring, remove the power connectors from the servo amplifier.</li> <li>● Insert only one wire or ferrule to each wire insertion hole.</li> <li>● These connectors are not available for MR-J4 1-axis servo amplifier of 5 kW or more.</li> <li>● Connect the power output (U, V, and W) and <math>\oplus</math> to terminal blocks for 5 kW or more servo amplifiers. For details, refer to each servo amplifier instruction manual.</li> </ul>

To wire to the servo amplifier, use connectors packed with the amplifier or optional connectors.

#### (1) Connector

- (a) MR-J4-20A(-RJ) to MR-J4-100A(-RJ)/MR-J4-20B(-RJ) to MR-J4-100B(-RJ)/MR-J4-20A1(-RJ)/MR-J4-40A1(-RJ)/MR-J4-20B1(-RJ)/MR-J4-40B1(-RJ)/MR-J4-20GF(-RJ) to MR-J4-100GF(-RJ)

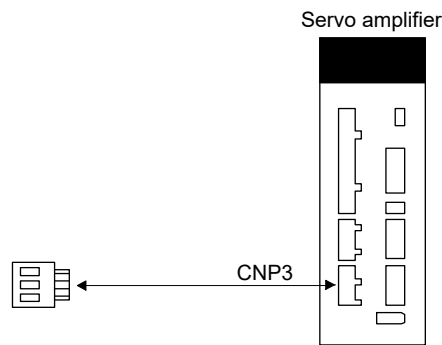

Table 4.4 Connector and applicable cable

Connector	Receptacle assembly	Applicable cable		Stripped length [mm]	Open tool	Manufacturer
		Wire size	Insulator OD			
CNP3	03JFAT-SAXGDK-H7.5	AWG 18 to 14	3.9 mm or less	9	J-FAT-OT (N) or J-FAT-OT	JST

## 4. CONNECTION OF SERVO AMPLIFIER AND LINEAR SERVO MOTOR

(b) MR-J4-200A(-RJ)/MR-J4-350A(-RJ)/MR-J4-200B(-RJ)/MR-J4-350B(-RJ)/MR-J4-200GF(-RJ)/MR-J4-350GF(-RJ)

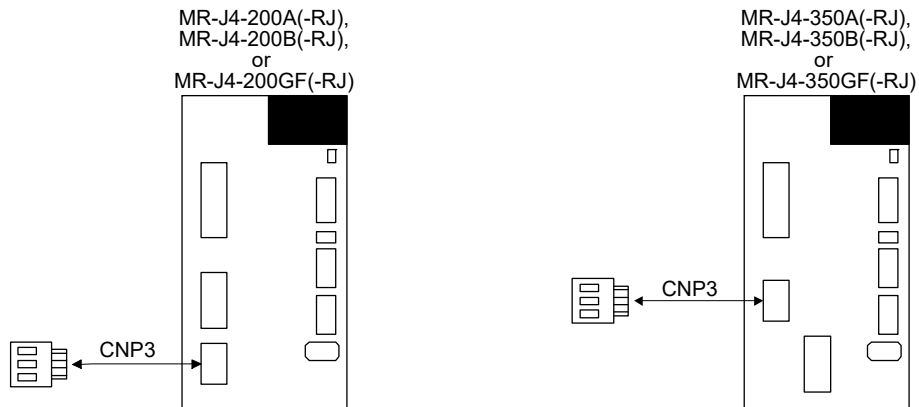
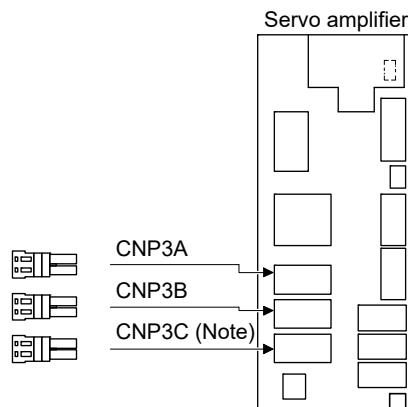

Table 4.5 Connector and applicable cable

Connector	Receptacle assembly	Applicable cable		Stripped length [mm]	Open tool	Manufacturer
		Wire size	Insulator OD			
CNP3	03JFAT-SAXGFK-XL	AWG 16 to 10	4.7 mm or less	11.5	J-FAT-OT-EXL	JST

(c) MR-J4W\_ - \_B



Note. This figure shows the MR-J4 3-axis servo amplifier.

Table 4.6 Connector and applicable cable

Connector	Receptacle assembly	Applicable wire size	Stripped length [mm]	Open tool	Manufacturer
CNP3A CNP3B CNP3C	04JFAT-SAGG-G-KK	AWG 18 to 14	9	J-FAT-OT-EXL	JST

## 4. CONNECTION OF SERVO AMPLIFIER AND LINEAR SERVO MOTOR

---

### (2) Cable connection procedure

#### (a) Cable making

Refer to table 4.4, 4.5 and 4.6 for stripped length of cable insulator. The appropriate stripped length of cables depends on their type, etc. Set the length considering their status.

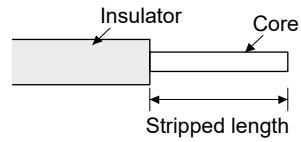

Twist strands slightly and straighten them as follows.

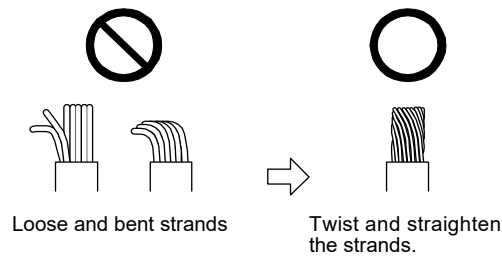

## 4. CONNECTION OF SERVO AMPLIFIER AND LINEAR SERVO MOTOR

---

### (b) Inserting wire

Insert only one wire or ferrule to each wire insertion hole.

Insert the open tool as follows and push it down to open the spring.

While the open tool is pushed down, insert the stripped wire into the wire insertion hole.

Check the insertion depth, and make sure that the cable insulator will not be caught by the spring and that the conductive part of the stripped wire will not be exposed.

Release the open tool to fix the wire. Pull the wire lightly to confirm that the wire is surely connected.

In addition, make sure that no conductor wire sticks out of the connector.

The following shows a connection example of the CNP3 connector for 2 kW and 3.5 kW of MR-J4 1-axis servo amplifier.

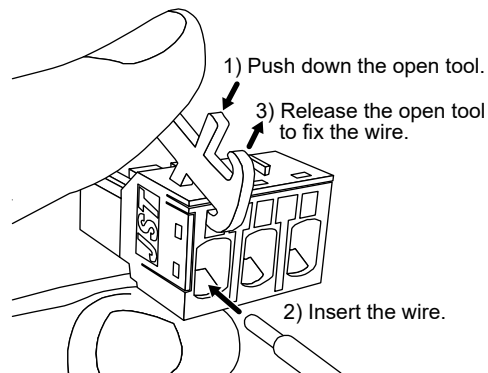

## 5. LINEAR SERVO MOTOR

### 5. LINEAR SERVO MOTOR

#### 5.1 Rating plate

The following shows an example of rating plate for explanation of each item.

#### (1) Primary side (coil)

##### (a) LM-H3/LM-F/LM-K2 series

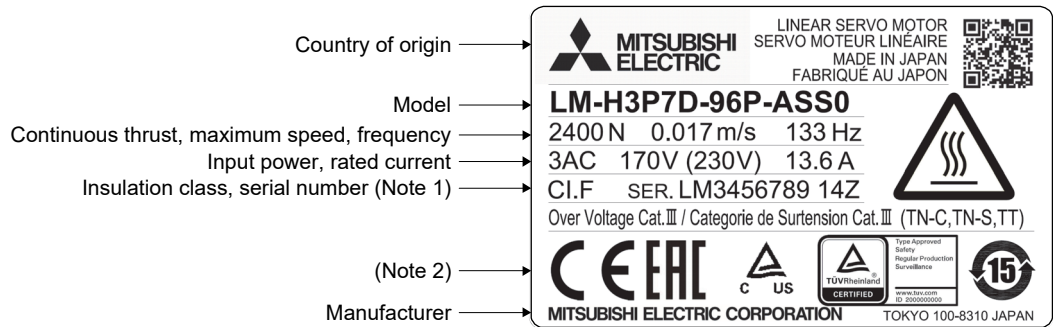

##### (b) LM-U2 series

##### 1) LM-U2PA\_/LM-U2PB\_ series



##### 2) LM-U2P2\_ series

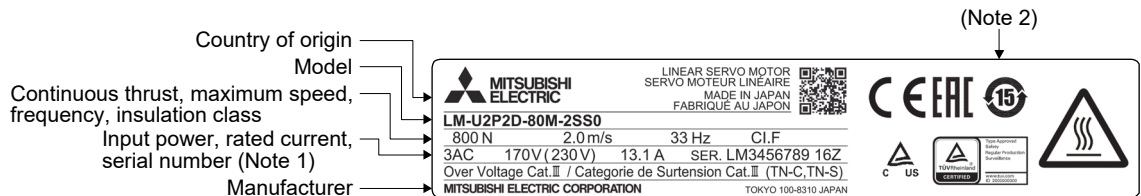

Note 1. Production year and month of the primary side of linear servo motor are indicated in a serial number on the rating plate.

The year and month are indicated by the last two digits of the year and one digit of the month [1 to 9, X(10), Y(11), and Z(12)].

For January 2012, the Serial No. is like, "SER. \_\_\_\_\_ 121".

2. Products approved by Certification Bodies are marked. The marks depends on the Certification Bodies.

## 5. LINEAR SERVO MOTOR

### (2) Secondary side (magnet)

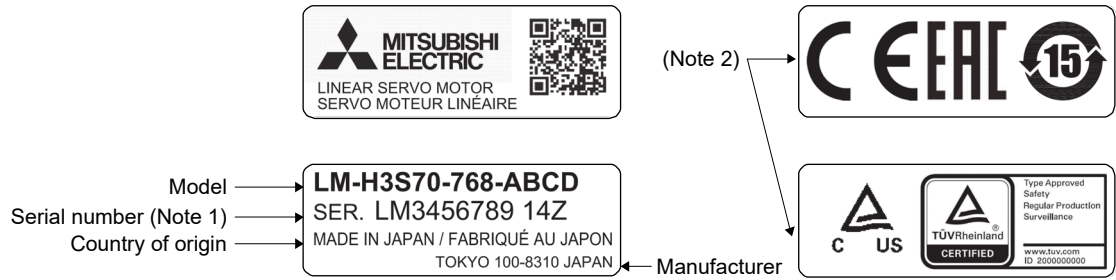

- Note 1. Production year and month of the secondary side of linear servo motor are indicated in a serial number on the rating plate.  
 The year and month are indicated by the last two digits of the year and one digit of the month [1 to 9, X(10), Y(11), and Z(12)].  
 For January 2012, the Serial No. is like, "SER. \_\_\_\_\_ 121".
2. Products approved by Certification Bodies are marked. The marks depends on the Certification Bodies.

# 5. LINEAR SERVO MOTOR

## 5.2 LM-H3 series

### 5.2.1 Model definition

The following describes what each block of a model name indicates. Not all combinations of the symbols are available.

#### (1) Primary side (coil)

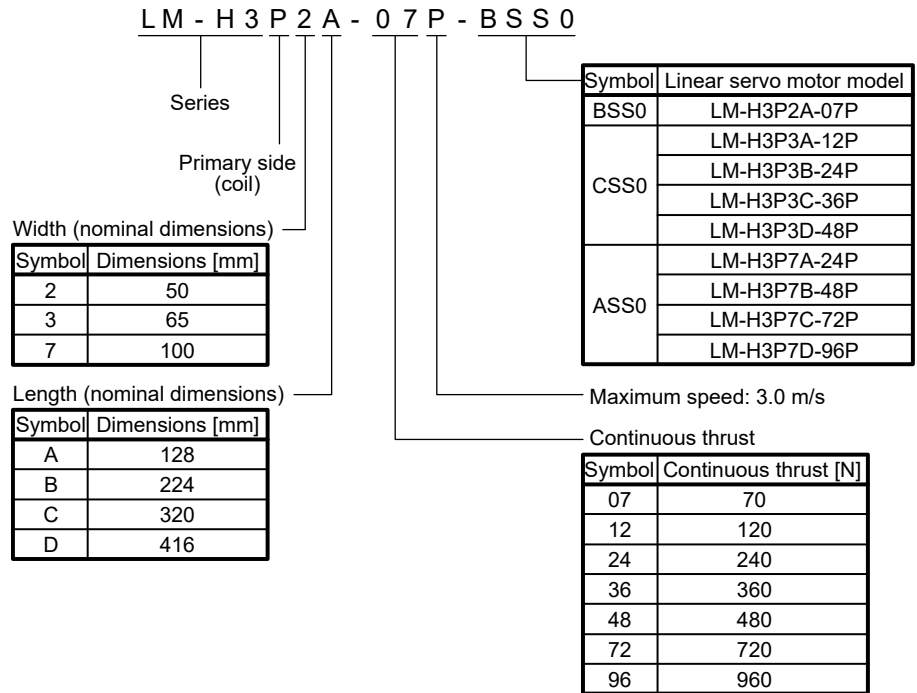

#### (2) Secondary side (magnet)

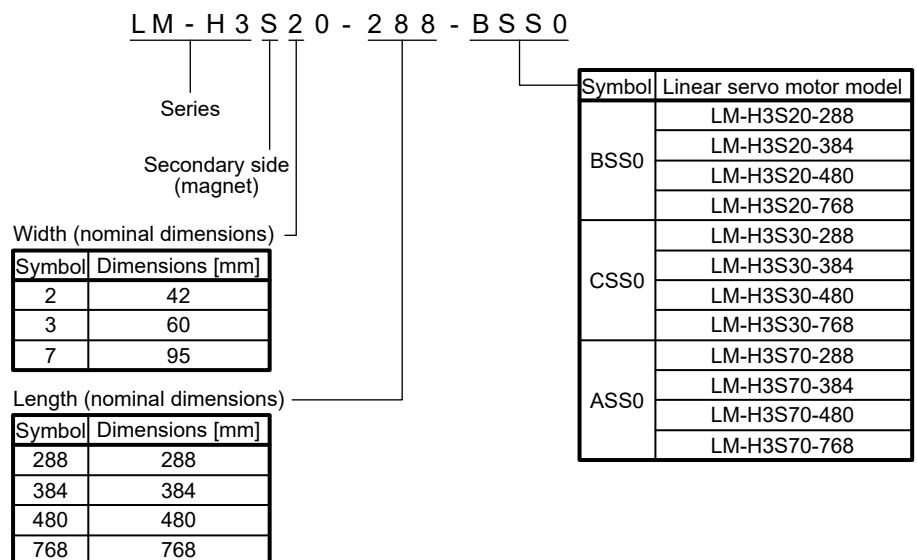

## 5. LINEAR SERVO MOTOR

### 5.2.2 Combinations of servo amplifiers and linear servo motors

POINT
<p>● Rotary servo motors, linear servo motors, and direct drive motors of any series and capacity can be used together if they are compatible with the MR-J4W_ _B servo amplifier.</p>

Linear servo motor		Servo amplifier (Note)
Primary side	Secondary side	
LM-H3P2A-07P-BSS0	LM-H3S20-288-BSS0 LM-H3S20-384-BSS0 LM-H3S20-480-BSS0 LM-H3S20-768-BSS0	MR-J4-40A(1)(-RJ) MR-J4-40B(1)(-RJ) MR-J4-40GF(-RJ) MR-J4W2-44B MR-J4W2-77B MR-J4W2-1010B MR-J4W3-444B
LM-H3P3A-12P-CSS0	LM-H3S30-288-CSS0 LM-H3S30-384-CSS0 LM-H3S30-480-CSS0 LM-H3S30-768-CSS0	MR-J4-40A(1)(-RJ) MR-J4-40B(1)(-RJ) MR-J4-40GF(-RJ) MR-J4W2-44B MR-J4W2-77B MR-J4W2-1010B MR-J4W3-444B
LM-H3P3B-24P-CSS0		MR-J4-70A(-RJ) MR-J4-70B(-RJ) MR-J4-70GF(-RJ)
LM-H3P3C-36P-CSS0		MR-J4W2-77B MR-J4W2-1010B
LM-H3P3D-48P-CSS0		MR-J4-200A(-RJ) MR-J4-200B(-RJ) MR-J4-200GF(-RJ)
LM-H3P7A-24P-ASS0	LM-H3S70-288-ASS0 LM-H3S70-384-ASS0 LM-H3S70-480-ASS0 LM-H3S70-768-ASS0	MR-J4-70A(-RJ) MR-J4-70B(-RJ) MR-J4-70GF(-RJ) MR-J4W2-77B MR-J4W2-1010B
LM-H3P7B-48P-ASS0		MR-J4-200A(-RJ) MR-J4-200B(-RJ) MR-J4-200GF(-RJ)
LM-H3P7C-72P-ASS0		MR-J4-350A(-RJ) MR-J4-350B(-RJ) MR-J4-350GF(-RJ)
LM-H3P7D-96P-ASS0		

Note. Set [Pr. PA17] and [Pr. PA18] according to the linear servo motor to be used.

## 5. LINEAR SERVO MOTOR

### 5.2.3 LM-H3 series specification list

Linear servo motor (primary side) LM-H3_		P2A-07P-BSS0	P3A-12P-CSS0	P3B-24P-CSS0	P3C-36P-CSS0	P3D-48P-CSS0	P7A-24P-ASS0	P7B-48P-ASS0	P7C-72P-ASS0	P7D-96P-ASS0	
Linear servo motor (secondary side) LM-H3_		S20-288-BSS0 S20-384-BSS0 S20-480-BSS0 S20-768-BSS0	S30-288-CSS0 S30-384-CSS0 S30-480-CSS0 S30-768-CSS0				S70-288-ASS0 S70-384-ASS0 S70-480-ASS0 S70-768-ASS0				
Power supply capacity [kVA]		Refer to "USING A LINEAR SERVO MOTOR" in each Servo Amplifier Instruction Manual.									
Cooling method		Natural cooling									
Thrust	Rated (Note 2, 4) [N]	70	120	240	360	480	240	480	720	960	
	Maximum [N]	175	300	600	900	1200	600	1200	1800	2400	
Maximum speed (Note 1) [m/s]		3.0									
Magnetic attraction force [N]		630	1100	2200	3300	4400	2200	4400	6600	8800	
Rated current [A]		1.8	1.7	3.4	5.1	6.8	3.4	6.8	10.2	13.6	
Maximum current [A]		5.8	5.0	9.9	14.9	19.8	9.6	19.1	28.6	38.1	
Recommended load to motor mass ratio		Less than 35 times of mass of linear servo motor primary side									
Thermistor		Built-in									
Insulation class		155 (F)									
Structure		Open (IP rating: IP00 (Note 3))									
Environment	Ambient temperature	Operation	0 °C to 40 °C (non-freezing)								
		Storage	-15 °C to 70 °C (non-freezing)								
	Ambient humidity	Operation	10 %RH to 80 %RH (non-condensing)								
		Storage	10 %RH to 90 %RH (non-condensing)								
	Ambience		Indoors (no direct sunlight) free from corrosive gas, flammable gas, oil mist, dust and dirt.								
	Altitude		1000 m or less above sea level								
Vibration resistance		49 m/s <sup>2</sup>									
Mass	Primary side [kg]	0.9	1.3	2.3	3.3	4.3	2.2	3.9	5.6	7.3	
	Secondary side [kg]	0.7 (288 mm one magnet) 0.9 (384 mm one magnet) 1.1 (480 mm one magnet) 1.8 (768 mm one magnet)	1.0 (288 mm one magnet) 1.4 (384 mm one magnet) 1.7 (480 mm one magnet) 2.7 (768 mm one magnet)				2.8 (288 mm one magnet) 3.7 (384 mm one magnet) 4.7 (480 mm one magnet) 7.4 (768 mm one magnet)				

- Note
- The maximum speed of linear servo motor is the smaller value of the maximum speed of linear servo motor and the rated speed of linear encoder.
  - The indicated value is when the aluminum board with the following dimensions (L [mm] × W [mm] × H [mm]) is mounted on the primary side. (reference value)  
 LM-H3P2A-07P-BSS0: 192 × 225 × 30  
 LM-H3P3A-12P-CSS0: 192 × 495 × 30  
 LM-H3P3B-24P-CSS0: 192 × 315 × 30  
 LM-H3P3C-36P-CSS0: 336 × 495 × 40  
 LM-H3P3D-48P-CSS0: 336 × 315 × 30  
 LM-H3P7A-24P-ASS0: 480 × 495 × 40  
 LM-H3P7B-48P-ASS0: 480 × 315 × 40  
 LM-H3P7C-72P-ASS0: 624 × 495 × 40  
 LM-H3P7D-96P-ASS0: 624 × 315 × 40
  - IP classifies the degrees of protection provided against the intrusion of solid objects and water in electrical enclosures.
  - Use the linear servo motor with 70% or less of the effective load ratio when it is in the servo lock state or in a small reciprocating motion.

# 5. LINEAR SERVO MOTOR

## 5.2.4 Thrust characteristics

The following shows thrust characteristic for when the power supply input of the servo amplifier is 3-phase 200 V AC, 1-phase 200 V AC, and 1-phase 100 V AC. The 1-phase 100 V AC power input is applicable to LM-H3P2A-07P-BSS0 and LM-H3P3A-12P-CSS0.

The continuous/max. thrust and max. speed of the linear servo motor are in the case of the rated power voltage and frequency of the combined servo amplifier.

### (1) 3-phase 200 V AC

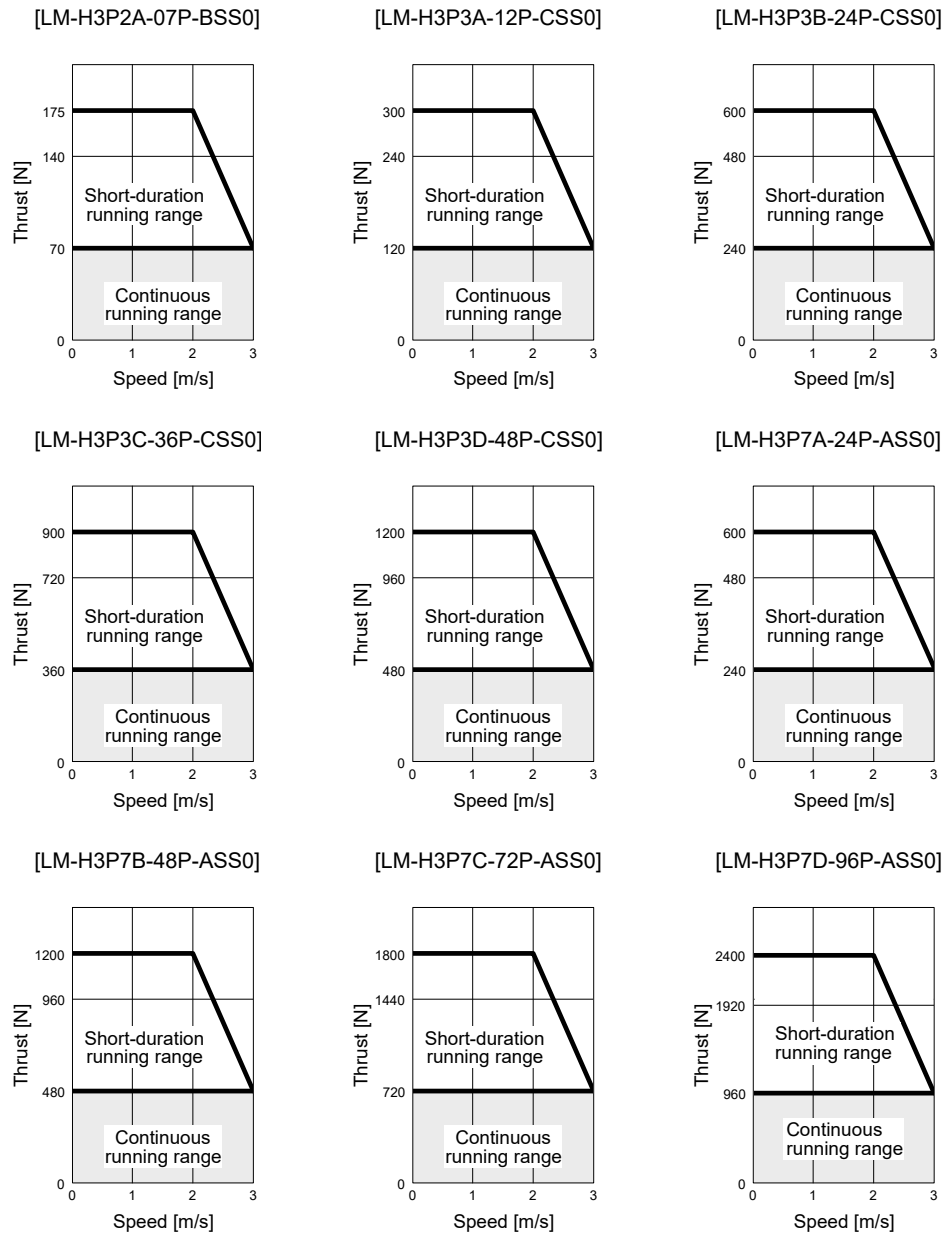

## 5. LINEAR SERVO MOTOR

(2) 1-phase 200 V AC and 1-phase 100 V AC

[LM-H3P2A-07P-BSS0]

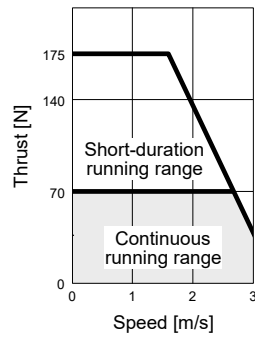

[LM-H3P3A-12P-CSS0]

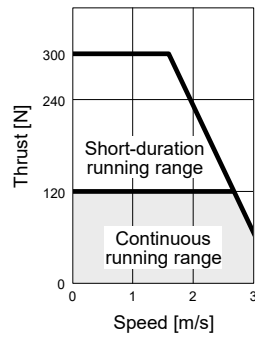

[LM-H3P3B-24P-CSS0]

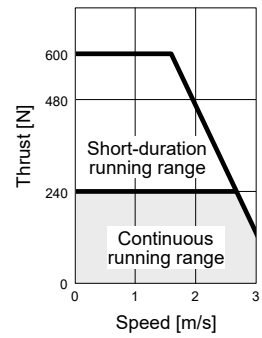

[LM-H3P3C-36P-CSS0]

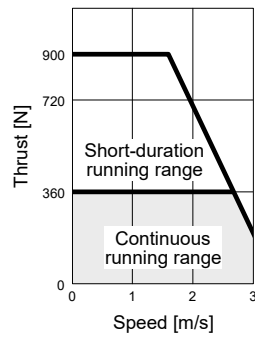

[LM-H3P3D-48P-CSS0]

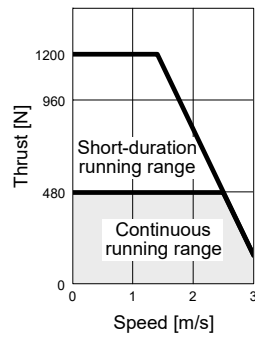

[LM-H3P7A-24P-ASS0]

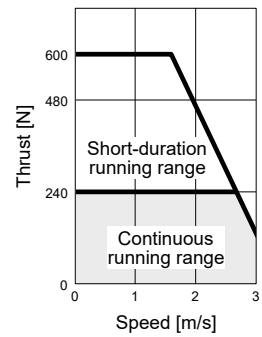

[LM-H3P7B-48P-ASS0]

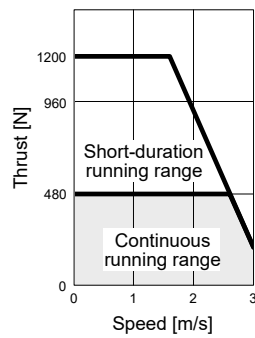

[LM-H3P7C-72P-ASS0]

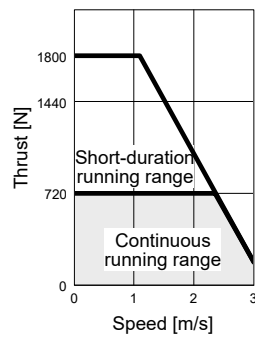

## 5. LINEAR SERVO MOTOR

### 5.2.5 Installation

#### (1) Installation procedure

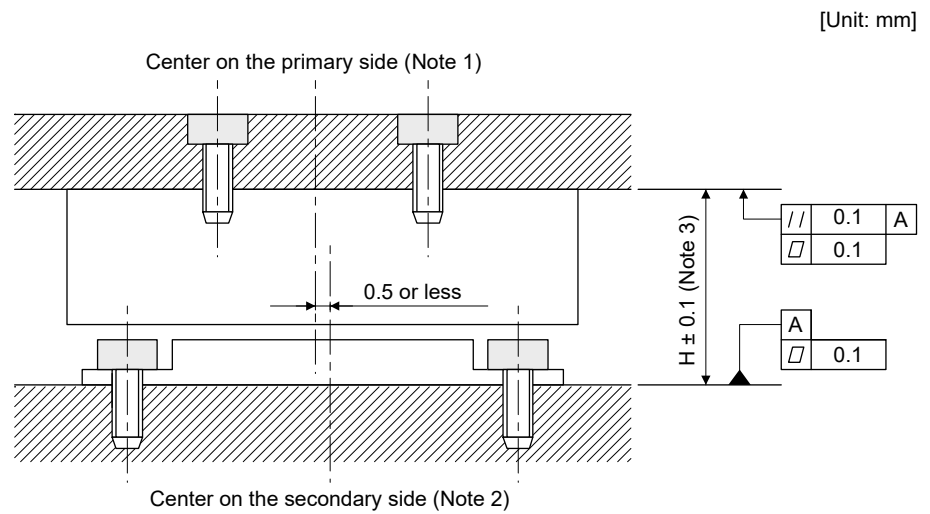

- Note 1. Centers on the primary side are as follows.  
 LM-H3P2\_ \_ : Center mounting screw position  
 LM-H3P3\_ \_ : Center of mounting screw pitch  
 LM-H3P7\_ \_ : Center mounting screw position
2. Centers on the secondary side is the center of mounting screw pitch.
3. H length indicates (height of primary side) + (height of secondary side) + (length of empty clearance: 0.7 mm).  
 LM-H3P2\_ \_ : H = 43.0 mm  
 LM-H3P3\_ \_ : H = 43.0 mm  
 LM-H3P7\_ \_ : H = 48.0 mm

## 5. LINEAR SERVO MOTOR

### (2) Installation of the secondary side (magnet)



**WARNING**

- The permanent magnet on the secondary side makes the magnetic bodies generate attraction force. Be careful not to get your hand stuck.



**CAUTION**

- When mounting the secondary side, use nonmagnetic tools.
- When the additional secondary side is mounted after one has been already set, slide the additional secondary side to mount it in its specified position after setting it away from the already mounted one as shown in this section.
- Keep the cumulative pitch error of the mounting screw holes within  $\pm 0.2$  mm. When two or more secondary sides are mounted, clearance may be left between the secondary sides depending on the mounting method and the number of secondary sides.

When using multiple secondary sides, arrange the name plates attached to the product in the same direction to keep the layout of magnetic poles.

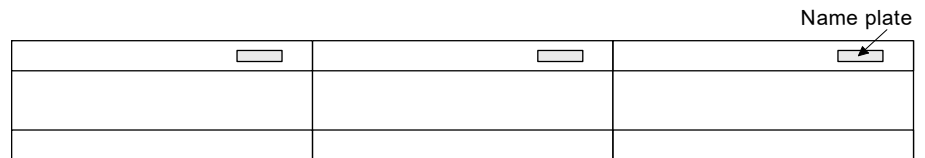

Then, mount them with the following procedure to decrease the clearance between the secondary sides.

Step 1. Securely fix with bolts the secondary side to be a mounting standard.

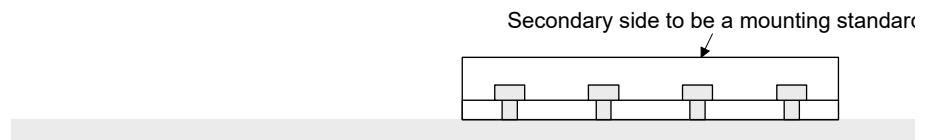

Step 2. Set the secondary side on the mounting face and fix it with bolts as temporary joint.

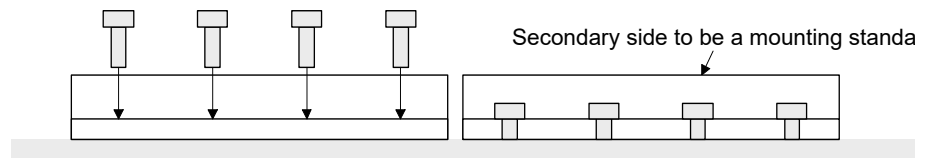

Step 3. Press the secondary side fixed as temporary joint toward that to be a mounting standard.

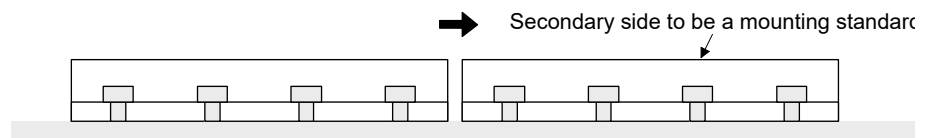

Step 4. Securely fix with bolts the secondary side fixed as temporary joint.

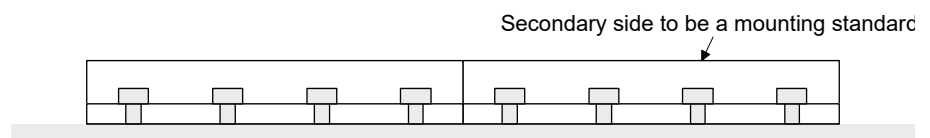

## 5. LINEAR SERVO MOTOR

### (3) Installation of the primary side (coil)



#### CAUTION

- To avoid the danger caused by attraction force generated between the primary side and the secondary side by the permanent magnet, it is recommended to install the primary side in the position free from the secondary side as shown in this section.
- When mounting the primary side over the secondary side unavoidably, use the material handling equipment such as crane which is fully competent to sustain the load of attraction force, etc.
- When sliding the primary side to move over the secondary side after setting, pay full attention to the attraction force generated.

Step 1. Mount a part of the secondary side.

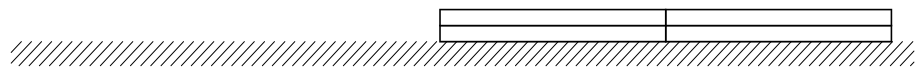

Step 2. Mount the primary side in the position free from the secondary side.

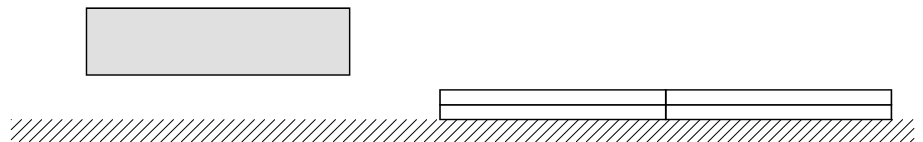

Step 3. Move the primary side over the mounted secondary side.  
Confirm that the primary side does not contact the secondary side.

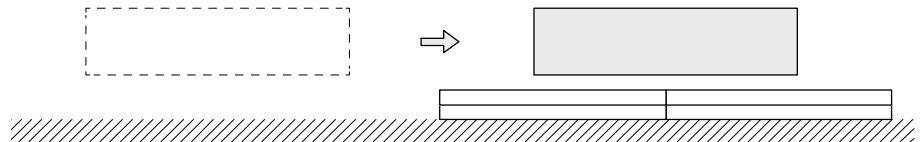

Step 4. Mount the rest of the secondary side.  
Confirm that the primary side does not contact the secondary side.

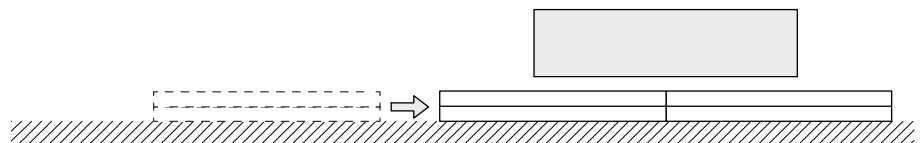

# 5. LINEAR SERVO MOTOR

## 5.2.6 Dimensions

### (1) Primary side (coil)

#### (a) LM-H3P2A-07P-BSS0

[Unit: mm]

Power lead wire (U, V, and W): black, grounding lead wire (E): green/yellow (Note 2)  
4 wires-AWG20 (standard overall diameter 2.12 mm)  
Effective length 400 mm

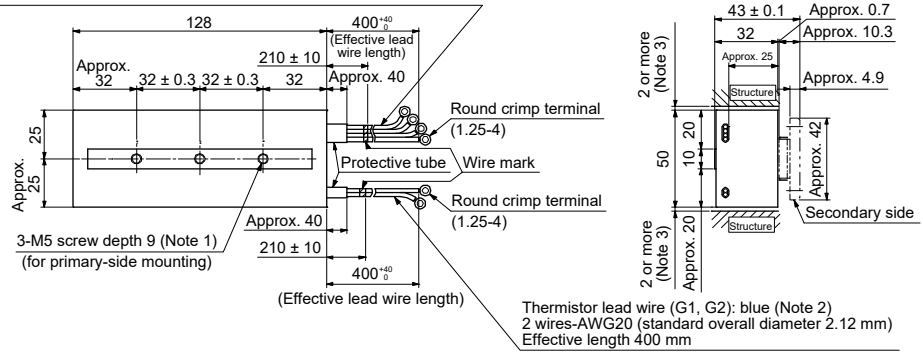

- Note 1. The recommended tightening torque of mounting screw is 7.0 N•m (permissible range: 6.0 N•m to 7.8 N•m).
- Note 2. This lead wire is for fixed wiring, so securely fix it to the structure.  
Minimum bending radius of the lead wire is recommended to be six times or more (reference value) the standard overall diameter of the lead wire. Select the cable used for the moving part considering the speed of linear servo motor and the flexing radius.
- Note 3. Leave 2 mm or more of each side of the clearance between the side face of primary side and the structure.

#### (b) LM-H3P3A-12P-CSS0

[Unit: mm]

Power lead wire (U, V, and W): black, grounding lead wire (E): green/yellow (Note 2)  
4 wires-AWG16 (standard overall diameter 2.7 mm)  
Effective length 400 mm

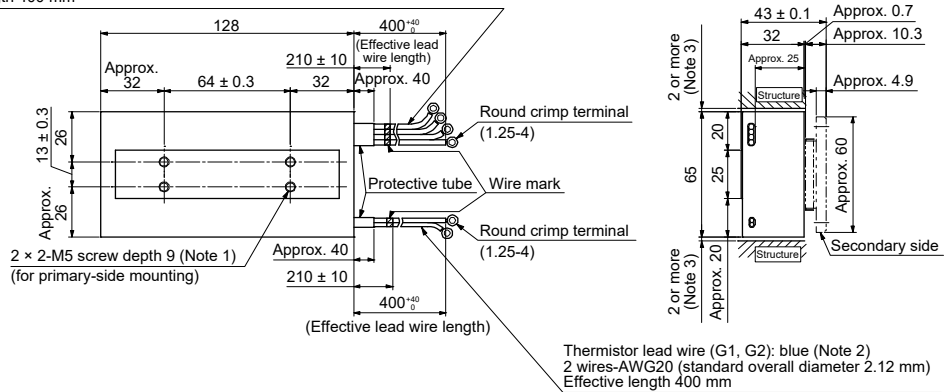

- Note 1. The recommended tightening torque of mounting screw is 7.0 N•m (permissible range: 6.0 N•m to 7.8 N•m).
- Note 2. This lead wire is for fixed wiring, so securely fix it to the structure.  
Minimum bending radius of the lead wire is recommended to be six times or more (reference value) the standard overall diameter of the lead wire. Select the cable used for the moving part considering the speed of linear servo motor and the flexing radius.
- Note 3. Leave 2 mm or more of each side of the clearance between the side face of primary side and the structure.

# 5. LINEAR SERVO MOTOR

## (c) LM-H3P3B-24P-CSS0

[Unit: mm]

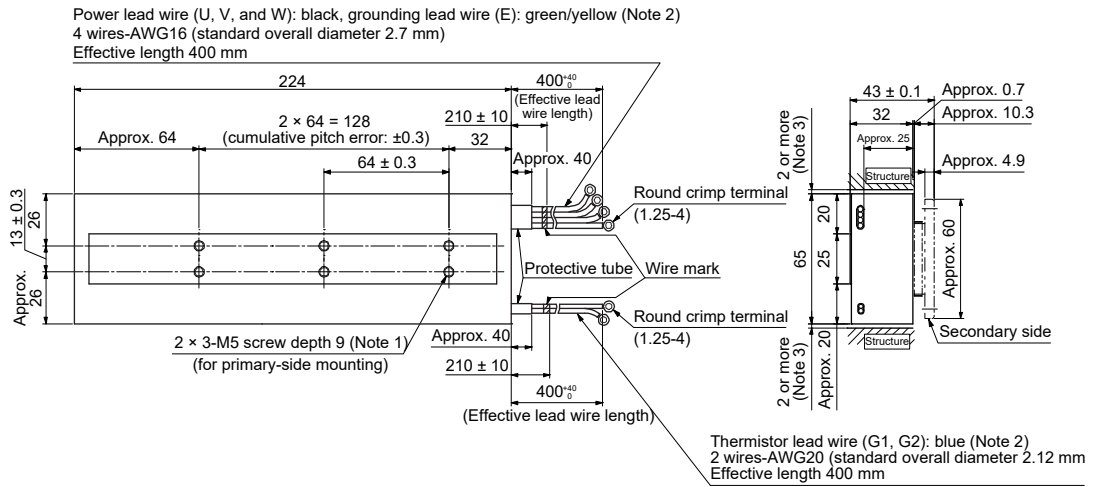

- Note 1. The recommended tightening torque of mounting screw is 7.0 N•m (permissible range: 6.0 N•m to 7.8 N•m).
2. This lead wire is for fixed wiring, so securely fix it to the structure.  
 Minimum bending radius of the lead wire is recommended to be six times or more (reference value) the standard overall diameter of the lead wire. Select the cable used for the moving part considering the speed of linear servo motor and the flexing radius.
3. Leave 2 mm or more of each side of the clearance between the side face of primary side and the structure.

## (d) LM-H3P3C-36P-CSS0

[Unit: mm]

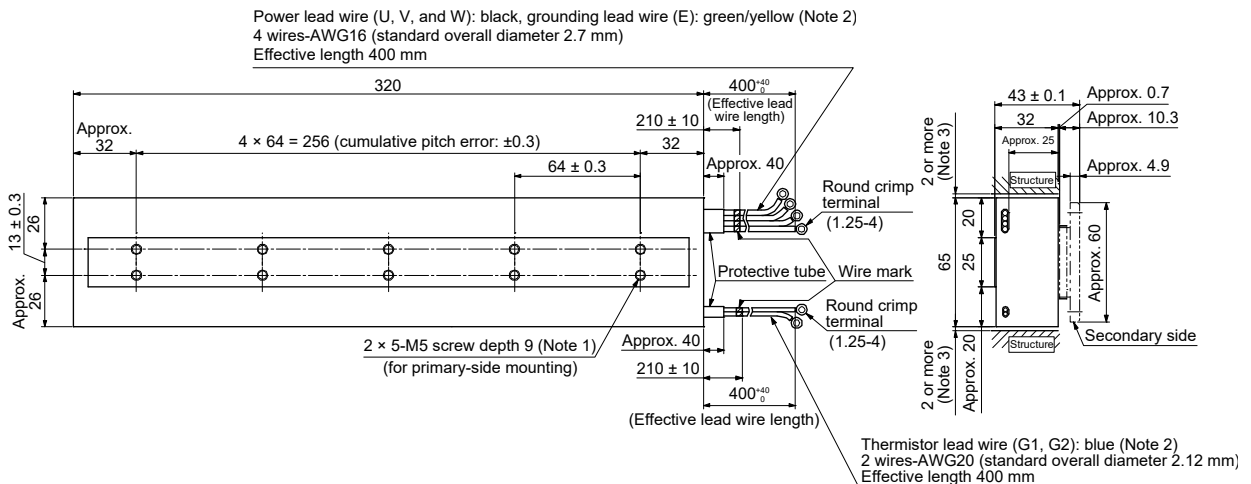

- Note 1. The recommended tightening torque of mounting screw is 7.0 N•m (permissible range: 6.0 N•m to 7.8 N•m).
2. This lead wire is for fixed wiring, so securely fix it to the structure.  
 Minimum bending radius of the lead wire is recommended to be six times or more (reference value) the standard overall diameter of the lead wire. Select the cable used for the moving part considering the speed of linear servo motor and the flexing radius.
3. Leave 2 mm or more of each side of the clearance between the side face of primary side and the structure.

# 5. LINEAR SERVO MOTOR

## (e) LM-H3P3D-48P-CSS0

[Unit: mm]

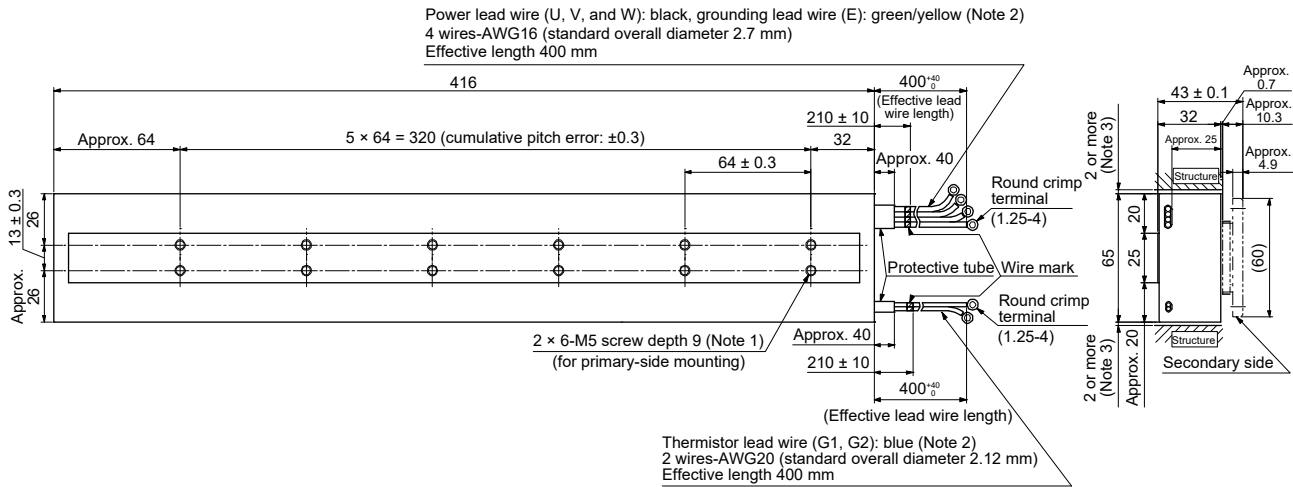

- Note 1. The recommended tightening torque of mounting screw is 7.0 N•m (permissible range: 6.0 N•m to 7.8 N•m).
- Note 2. This lead wire is for fixed wiring, so securely fix it to the structure.  
 Minimum bending radius of the lead wire is recommended to be six times or more (reference value) the standard overall diameter of the lead wire. Select the cable used for the moving part considering the speed of linear servo motor and the flexing radius.
- Note 3. Leave 2 mm or more of each side of the clearance between the side face of primary side and the structure.

## (f) LM-H3P7A-24P-ASS0

[Unit: mm]

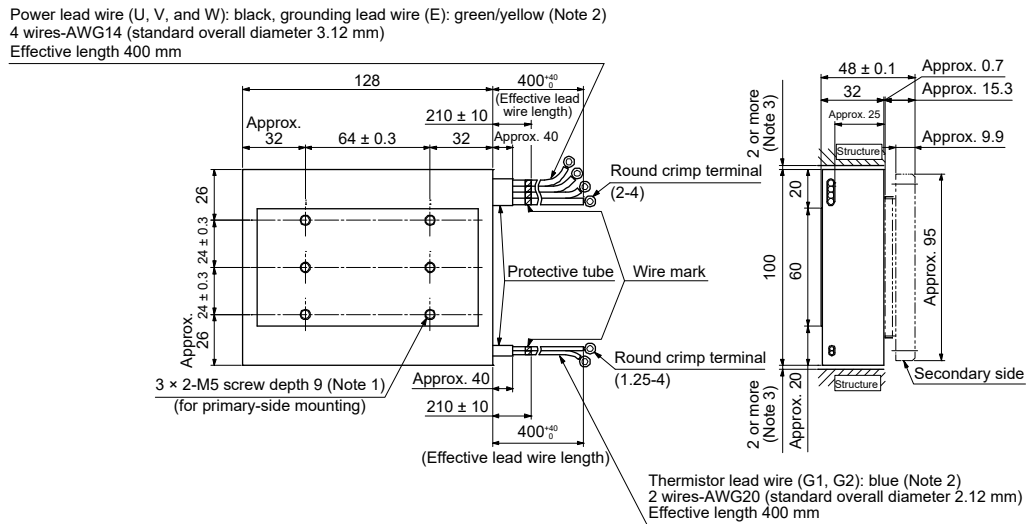

- Note 1. The recommended tightening torque of mounting screw is 7.0 N•m (permissible range: 6.0 N•m to 7.8 N•m).
- Note 2. This lead wire is for fixed wiring, so securely fix it to the structure.  
 Minimum bending radius of the lead wire is recommended to be six times or more (reference value) the standard overall diameter of the lead wire. Select the cable used for the moving part considering the speed of linear servo motor and the flexing radius.
- Note 3. Leave 2 mm or more of each side of the clearance between the side face of primary side and the structure.

# 5. LINEAR SERVO MOTOR

## (g) LM-H3P7B-48P-ASS0

[Unit: mm]

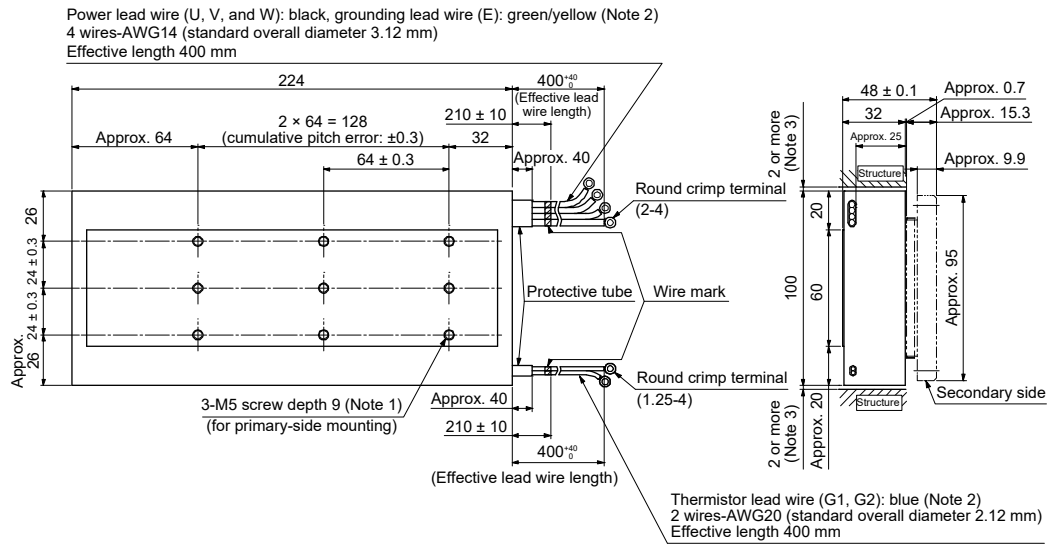

- Note 1. The recommended tightening torque of mounting screw is 7.0 N•m (permissible range: 6.0 N•m to 7.8 N•m).
2. This lead wire is for fixed wiring, so securely fix it to the structure.  
 Minimum bending radius of the lead wire is recommended to be six times or more (reference value) the standard overall diameter of the lead wire. Select the cable used for the moving part considering the speed of linear servo motor and the flexing radius.
3. Leave 2 mm or more of each side of the clearance between the side face of primary side and the structure.

## (h) LM-H3P7C-72P-ASS0

[Unit: mm]

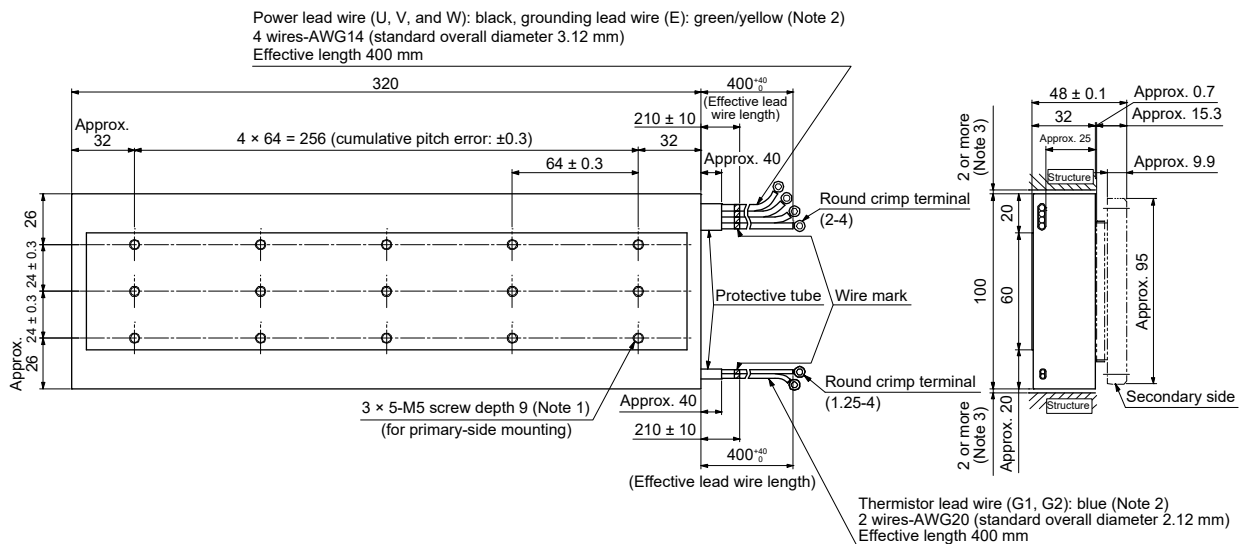

- Note 1. The recommended tightening torque of mounting screw is 7.0 N•m (permissible range: 6.0 N•m to 7.8 N•m).
2. This lead wire is for fixed wiring, so securely fix it to the structure.  
 Minimum bending radius of the lead wire is recommended to be six times or more (reference value) the standard overall diameter of the lead wire. Select the cable used for the moving part considering the speed of linear servo motor and the flexing radius.
3. Leave 2 mm or more of each side of the clearance between the side face of primary side and the structure.

# 5. LINEAR SERVO MOTOR

## (i) LM-H3P7D-96P-ASS0

[Unit: mm]

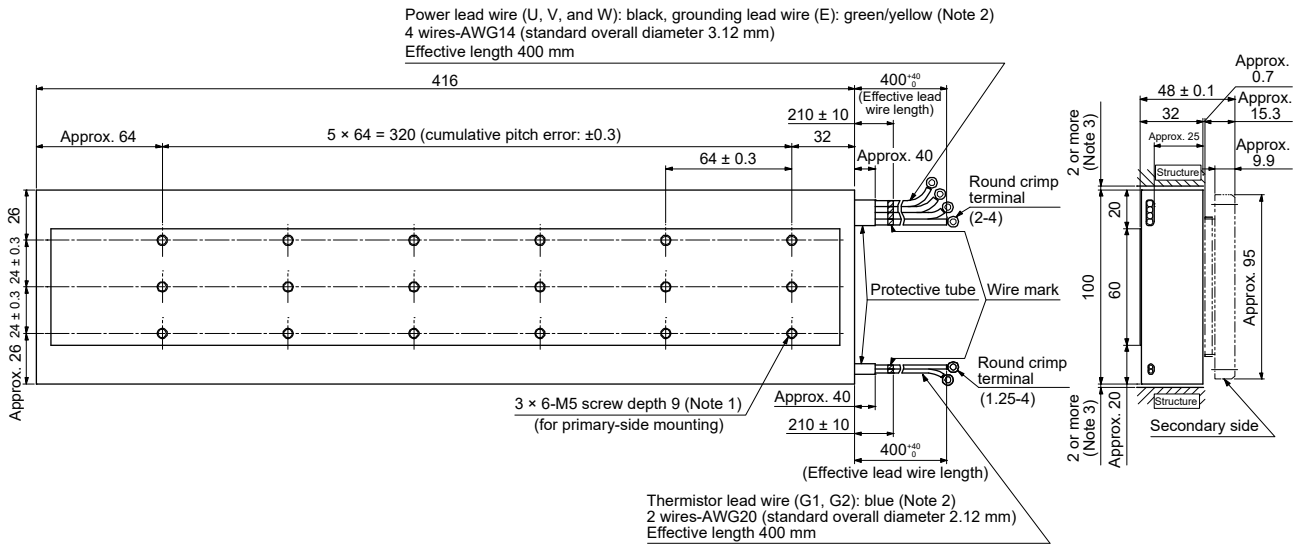

- Note 1. The recommended tightening torque of mounting screw is 7.0 N•m (permissible range: 6.0 N•m to 7.8 N•m).  
 2. This lead wire is for fixed wiring, so securely fix it to the structure.  
 Minimum bending radius of the lead wire is recommended to be six times or more (reference value) the standard overall diameter of the lead wire. Select the cable used for the moving part considering the speed of linear servo motor and the flexing radius.  
 3. Leave 2 mm or more of each side of the clearance between the side face of primary side and the structure.

## (2) Secondary side (magnet) (a) LM-H3S20-\_-BSS0

[Unit: mm]

Model	Variable dimensions		
	L	M	B
LM-H3S20-288-BSS0	288	5 × 48 = 240	2 × 6
LM-H3S20-384-BSS0	384	7 × 48 = 336	2 × 8
LM-H3S20-480-BSS0	480	9 × 48 = 432	2 × 10
LM-H3S20-768-BSS0	768	15 × 48 = 720	2 × 16

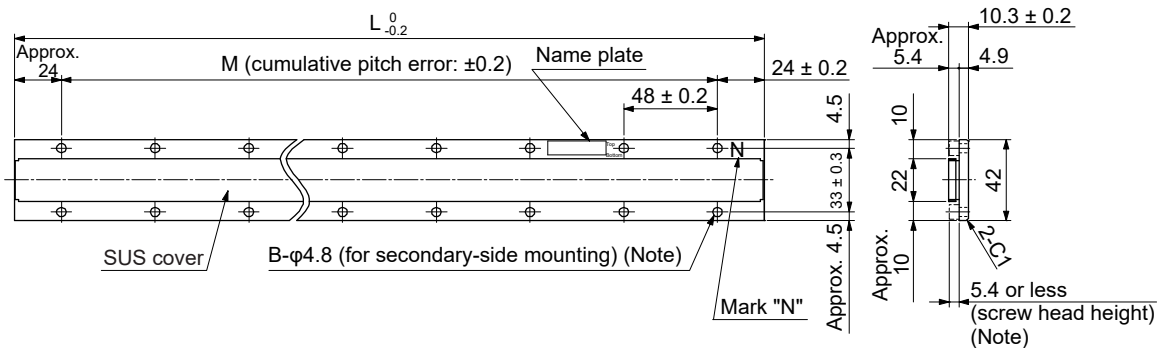

Note. For mounting, use the hexagonal cap head bolt whose screw head height is 5.4 mm or less.

## 5. LINEAR SERVO MOTOR

### (b) LM-H3S30-\_-CSS0

[Unit: mm]

Model	Variable dimensions		
	L	M	B
LM-H3S30-288-CSS0	288	5 × 48 = 240	2 × 6
LM-H3S30-384-CSS0	384	7 × 48 = 336	2 × 8
LM-H3S30-480-CSS0	480	9 × 48 = 432	2 × 10
LM-H3S30-768-CSS0	768	15 × 48 = 720	2 × 16

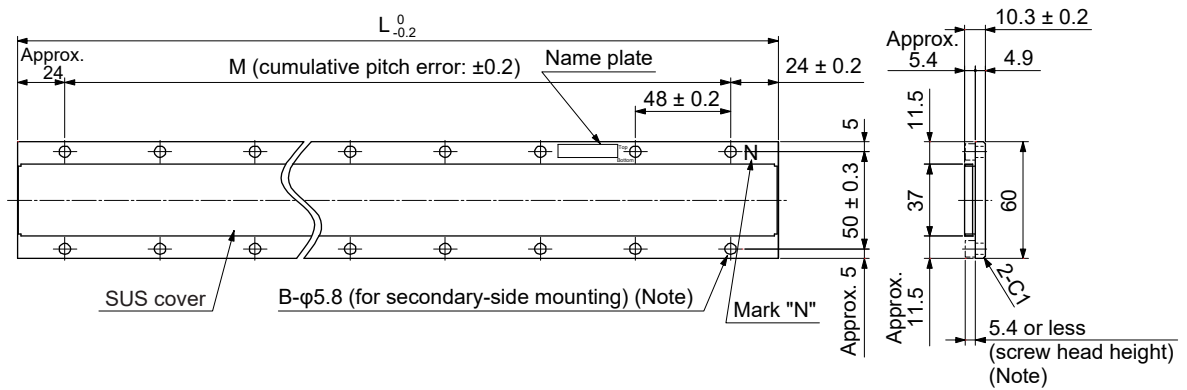

Note. For mounting, use the hexagonal cap head bolt whose screw head height is 5.4 mm or less.

### (c) LM-H3S70-\_-ASS0

[Unit: mm]

Model	Variable dimensions		
	L	M	B
LM-H3S70-288-ASS0	288	5 × 48 = 240	2 × 6
LM-H3S70-384-ASS0	384	7 × 48 = 336	2 × 8
LM-H3S70-480-ASS0	480	9 × 48 = 432	2 × 10
LM-H3S70-768-ASS0	768	15 × 48 = 720	2 × 16

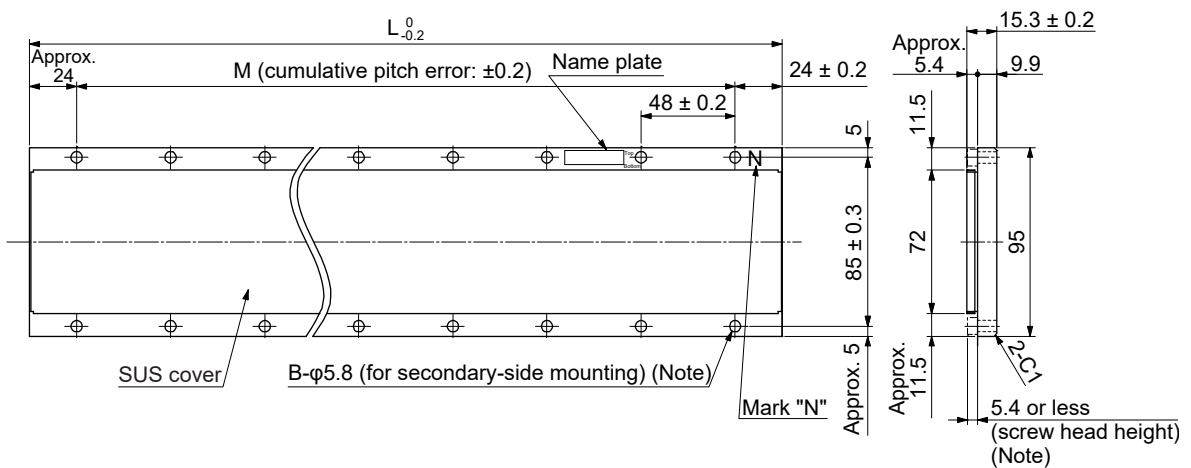

Note. For mounting, use the hexagonal cap head bolt whose screw head height is 5.4 mm or less.

## 5. LINEAR SERVO MOTOR

### 5.3 LM-U2 series

#### 5.3.1 Model definition

The following describes what each block of a model name indicates. Not all combinations of the symbols are available.

- (1) Medium thrust series  
 (a) Primary side (coil)

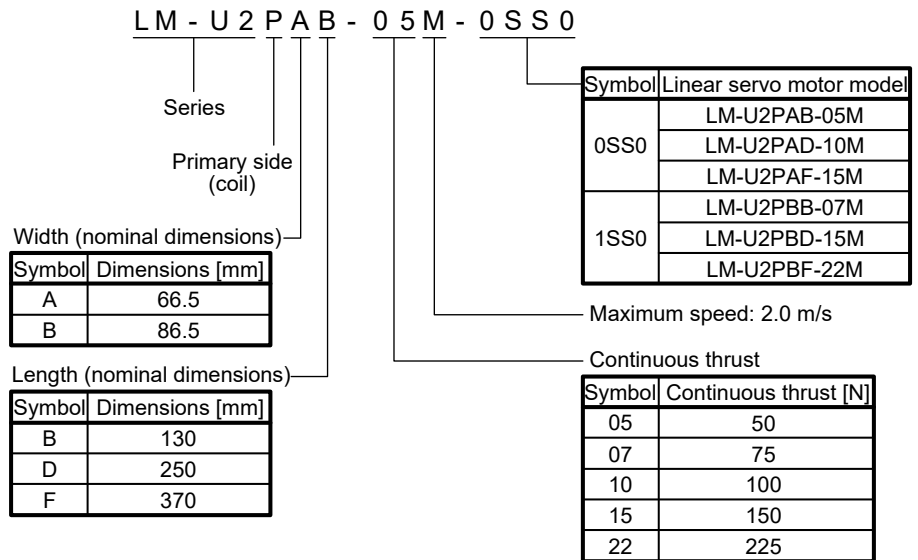

- (b) Secondary side (magnet)

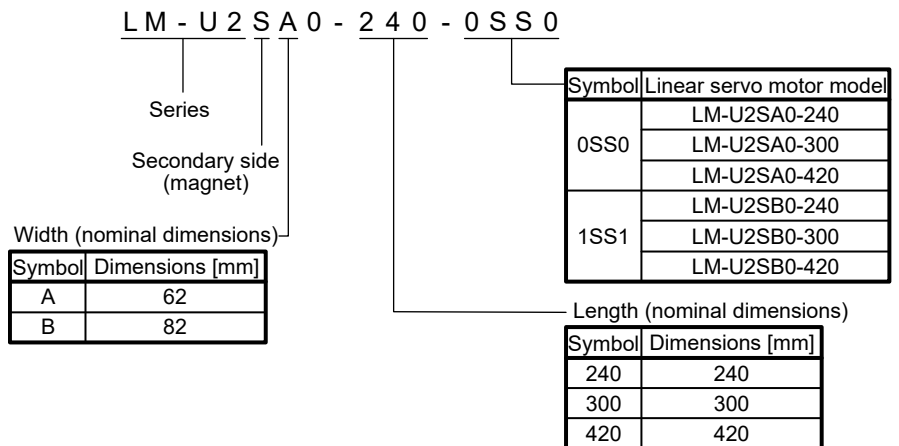

# 5. LINEAR SERVO MOTOR

## (2) Large thrust series

### (a) Primary side (coil)

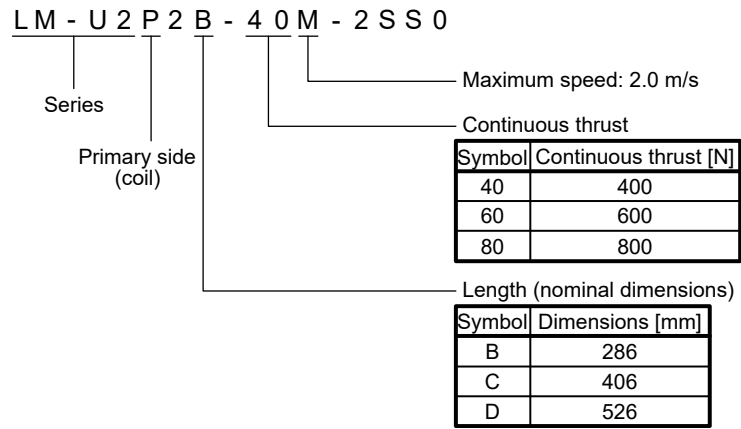

### (b) Secondary side (magnet)

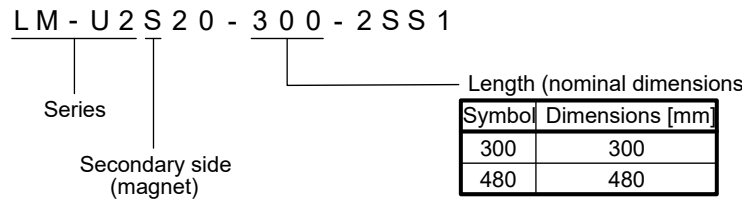

## 5. LINEAR SERVO MOTOR

### 5.3.2 Combinations of servo amplifiers and linear servo motors

POINT
<ul style="list-style-type: none"> <li>● Rotary servo motors, linear servo motors, and direct drive motors of any series and capacity can be used together if they are compatible with the MR-J4W_ _B servo amplifier.</li> </ul>

Linear servo motor		Servo amplifier (Note)
Primary side	Secondary side	
LM-U2PAB-05M-0SS0	LM-U2SA0-240-0SS0 LM-U2SA0-300-0SS0 LM-U2SA0-420-0SS0	MR-J4-20A(1)(-RJ) MR-J4-20B(1)(-RJ) MR-J4-20GF(-RJ) MR-J4W2-22B MR-J4W2-44B MR-J4W3-222B MR-J4W3-444B
LM-U2PAD-10M-0SS0		MR-J4-40A(1)(-RJ) MR-J4-40B(1)(-RJ) MR-J4-40GF(-RJ) MR-J4W2-44B MR-J4W2-77B MR-J4W2-1010B MR-J4W3-444B
LM-U2PAF-15M-0SS0		MR-J4-40A(1)(-RJ) MR-J4-40B(1)(-RJ) MR-J4-40GF(-RJ) MR-J4W2-44B MR-J4W2-77B MR-J4W2-1010B MR-J4W3-444B
LM-U2PBB-07M-1SS0	LM-U2SB0-240-1SS1 LM-U2SB0-300-1SS1 LM-U2SB0-420-1SS1	MR-J4-20A(1)(-RJ) MR-J4-20B(1)(-RJ) MR-J4-20GF(-RJ) MR-J4W2-22B MR-J4W2-44B MR-J4W3-222B MR-J4W3-444B
LM-U2PBD-15M-1SS0		MR-J4-60A(-RJ) MR-J4-60B(-RJ) MR-J4-60GF(-RJ) MR-J4W2-77B MR-J4W2-1010B
LM-U2PBF-22M-1SS0		MR-J4-70A(-RJ) MR-J4-70B(-RJ) MR-J4-70GF(-RJ) MR-J4W2-77B MR-J4W2-1010B
LM-U2P2B-40M-2SS0	LM-U2S20-300-2SS1 LM-U2S20-480-2SS1	MR-J4-200A(-RJ) MR-J4-200B(-RJ) MR-J4-200GF(-RJ)
LM-U2P2C-60M-2SS0		MR-J4-350A(-RJ) MR-J4-350B(-RJ) MR-J4-350GF(-RJ)
LM-U2P2D-80M-2SS0		MR-J4-500A(-RJ) MR-J4-500B(-RJ) MR-J4-500GF(-RJ)

Note. Set [Pr. PA17] and [Pr. PA18] according to the linear servo motor to be used.

## 5. LINEAR SERVO MOTOR

### 5.3.3 LM-U2 series specification list

Linear servo motor (primary side) LM-U2_		PAB-05M-0SS0	PAD-10M-0SS0	PAF-15M-0SS0	PBB-07M-1SS0	PBD-15M-1SS0	PBF-22M-1SS0
Linear servo motor (secondary side) LM-U2_		SA0-240-0SS0 SA0-300-0SS0 SA0-420-0SS0			SB0-240-1SS1 SB0-300-1SS1 SB0-420-1SS1		
Power supply capacity [kVA]		Refer to "USING A LINEAR SERVO MOTOR" in each Servo Amplifier Instruction Manual.					
Cooling method		Natural cooling					
Thrust	Rated (Note 2, 4) [N]	50	100	150	75	150	225
	Maximum [N]	150	300	450	225	450	675
Maximum speed (Note 1) [m/s]		2.0					
Magnetic attraction force [N]		0					
Rated current [A]		0.9	1.9	2.7	1.5	3.0	4.6
Maximum current [A]		2.7	5.5	8.3	4.5	8.9	13.7
Recommended load to motor mass ratio		Less than 30 times of mass of linear servo motor primary side					
Thermistor		Built-in					
Insulation class		155 (F)					
Structure		Open (IP rating: IP00 (Note 3))					
Environment	Ambient temperature	Operation	0 °C to 40 °C (non-freezing)				
		Storage	-15 °C to 70 °C (non-freezing)				
	Ambient humidity	Operation	10 %RH to 80 %RH (non-condensing)				
		Storage	10 %RH to 90 %RH (non-condensing)				
	Ambience		Indoors (no direct sunlight) free from corrosive gas, flammable gas, oil mist, dust and dirt.				
	Altitude		1000 m or less above sea level				
Vibration resistance		49 m/s <sup>2</sup>					
Mass	Primary side [kg]	0.3	0.6	0.8	0.4	0.8	1.1
	Secondary side [kg]	2.0 (240 mm one magnet) 2.5 (300 mm one magnet) 3.5 (420 mm one magnet)			2.6 (240 mm one magnet) 3.2 (300 mm one magnet) 4.5 (420 mm one magnet)		

## 5. LINEAR SERVO MOTOR

Linear servo motor (primary side) LM-U2_		P2B-40M-2SS0	P2C-60M-2SS0	P2D-80M-2SS0
Linear servo motor (secondary side) LM-U2_		S20-300-2SS1 S20-480-2SS1		
Power supply capacity [kVA]		Refer to "USING A LINEAR SERVO MOTOR" in each Servo Amplifier Instruction Manual.		
Cooling method		Natural cooling		
Thrust	Rated (Note 2, 4) [N]	400	600	800
	Maximum [N]	1600	2400	3200
Maximum speed (Note 1) [m/s]		2.0		
Magnetic attraction force [N]		0		
Rated current [A]		6.6	9.8	13.1
Maximum current [A]		26.7	40.3	53.7
Recommended load to motor mass ratio		Less than 30 times of mass of linear servo motor primary side		
Thermistor		Built-in		
Insulation class		155 (F)		
Structure		Open (IP rating: IP00 (Note 3))		
Environment	Ambient temperature	Operation	0 °C to 40 °C (non-freezing)	
		Storage	-15 °C to 70 °C (non-freezing)	
	Ambient humidity	Operation	10 %RH to 80 %RH (non-condensing)	
		Storage	10 %RH to 90 %RH (non-condensing)	
	Ambience		Indoors (no direct sunlight) free from corrosive gas, flammable gas, oil mist, dust and dirt.	
	Altitude		1000 m or less above sea level	
Vibration resistance		49 m/s <sup>2</sup>		
Mass	Primary side [kg]	2.9	4.2	5.5
	Secondary side [kg]	9.6 (300 mm one magnet) 15.3 (480 mm one magnet)		

- Note 1. The maximum speed of linear servo motor is the smaller value of the maximum speed of linear servo motor and the rated speed of linear encoder.
2. The indicated value is when the aluminum board with the following dimensions (L [mm] × W [mm] × H [mm]) is mounted on the primary side. (reference value)
- LM-U2PAB-05M-0SS0: 300 × 400 × 15
  - LM-U2PAD-10M-0SS0: 400 × 500 × 15
  - LM-U2PAF-15M-0SS0: 500 × 600 × 15
  - LM-U2PBB-07M-1SS0: 300 × 400 × 15
  - LM-U2PBD-15M-1SS0: 400 × 500 × 15
  - LM-U2PBF-22M-1SS0: 500 × 600 × 15
  - LM-U2P2B-40M-2SS0: 900 × 800 × 12
  - LM-U2P2C-60M-2SS0: 900 × 800 × 12
  - LM-U2P2D-80M-2SS0: 990 × 800 × 12
3. IP classifies the degrees of protection provided against the intrusion of solid objects and water in electrical enclosures.
4. Use the linear servo motor with 70% or less of the effective load ratio when it is in the servo lock state or in a small reciprocating motion.

# 5. LINEAR SERVO MOTOR

## 5.3.4 Thrust characteristics

The following shows thrust characteristic for when the power supply input of the servo amplifier is 3-phase 200 V AC, 1-phase 200 V AC, and 1-phase 100 V AC. The 1-phase 200 V AC power input is applicable to LM-U2PAB-05M-0SS0, LM-U2PAD-10M-0SS0, LM-U2PAF-15M-0SS0, LM-U2PBB-07M-1SS0, LM-U2PBD-15M-1SS0, LM-U2PBF-22M-1SS0, and LM-U2P2B-40M-2SS0. For the 1-phase 200 V AC power supply, the continuous line indicates the thrust characteristic.

The continuous/max. thrust and max. speed of the linear servo motor are in the case of the rated power voltage and frequency of the combined servo amplifier.

### (1) 3-phase 200 V AC and 1-phase 200 V AC

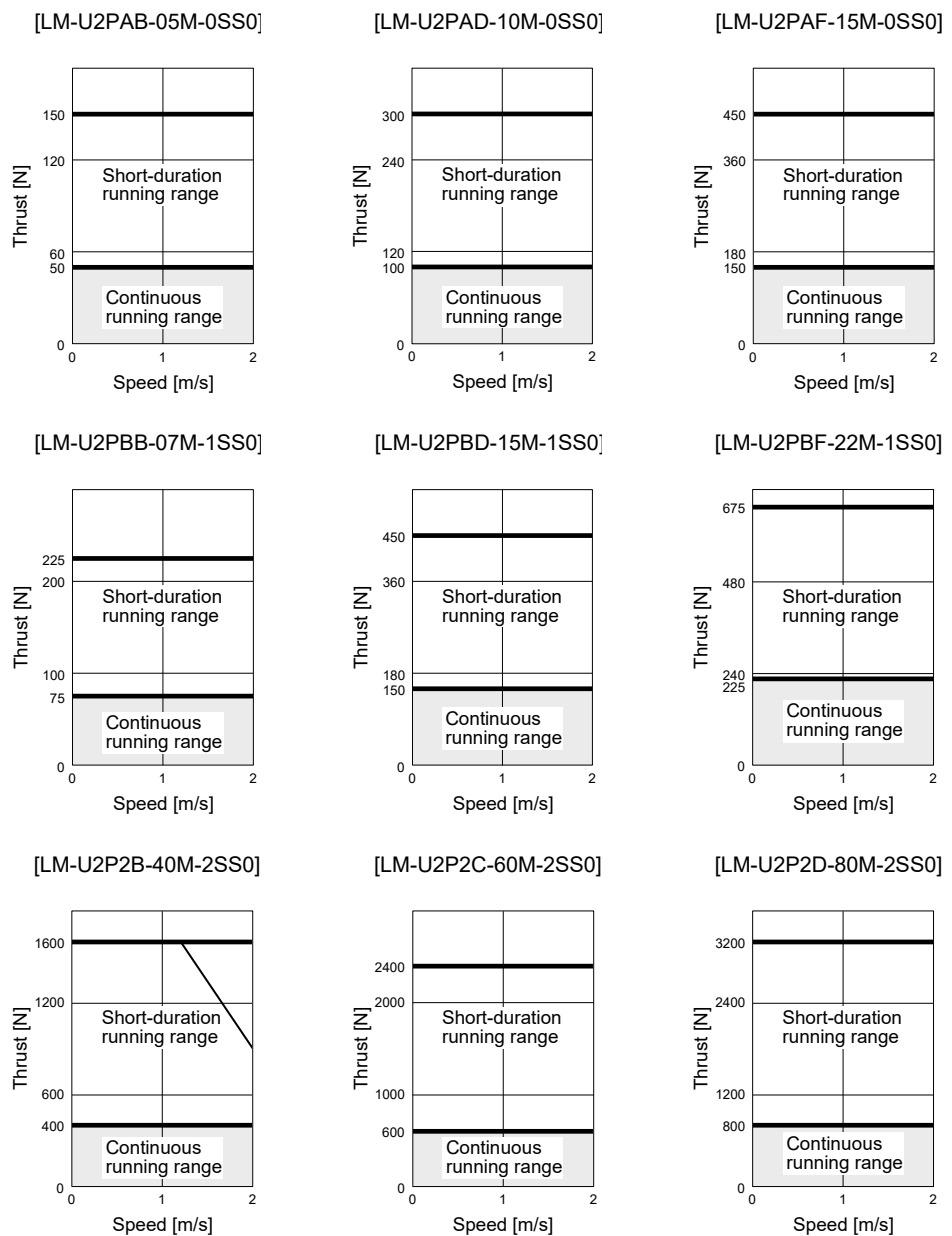

# 5. LINEAR SERVO MOTOR

(2) 1-phase 100 V AC

[LM-U2PAB-05M-0SS0]

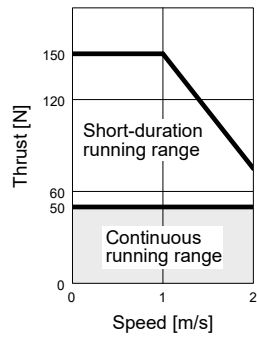

[LM-U2PAD-10M-0SS0]

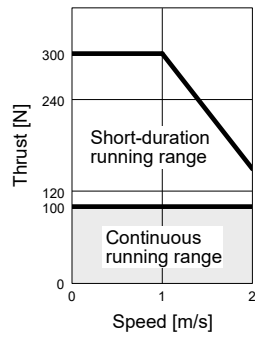

[LM-U2PAF-15M-0SS0]

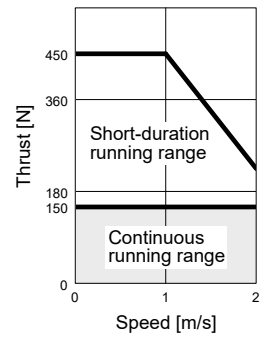

[LM-U2PBB-07M-1SS0]

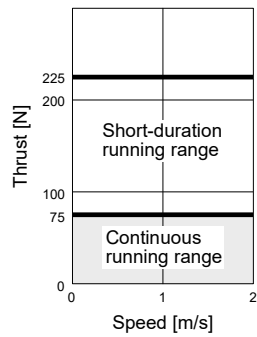

## 5. LINEAR SERVO MOTOR

### 5.3.5 Installation

#### (1) Mounting dimensions

##### (a) LM-U2PAB-05M-0SS0/LM-U2PAD-10M-0SS0/LM-U2PAF-15M-0SS0

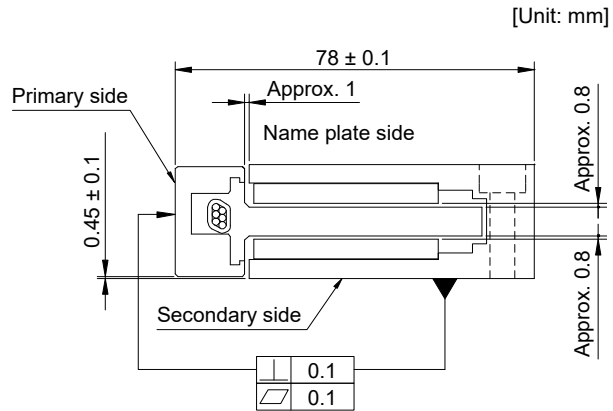

##### (b) LM-U2PBB-07M-1SS0/LM-U2PBD-15M-1SS0/LM-U2PBF-22M-1SS0

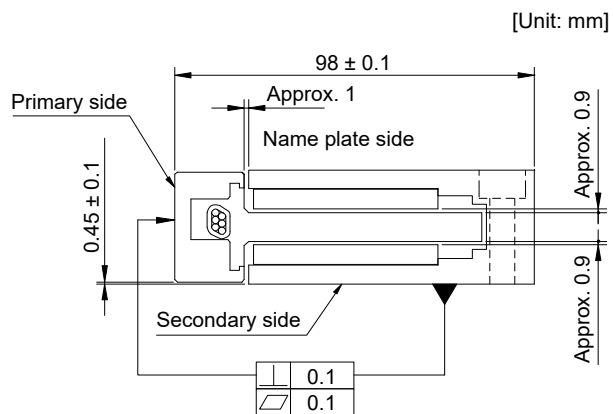

##### (c) LM-U2P2B-40M-2SS0/LM-U2P2C-60M-2SS0/LM-U2P2D-80M-2SS0

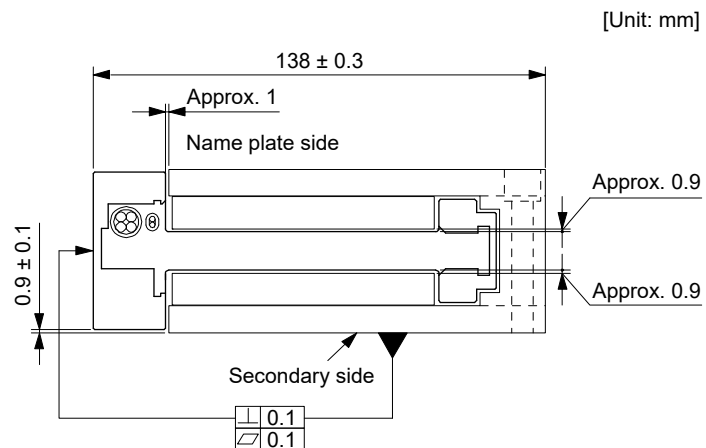

## 5. LINEAR SERVO MOTOR

### (2) Installation of the secondary side (magnet)



**WARNING** ●The permanent magnet on the secondary side makes the magnetic bodies generate attraction force. Be careful not to get your hand stuck



- When mounting the secondary side, use nonmagnetic tools.
- When the additional secondary side is mounted after one has been already set, slide the additional secondary side to mount it in its specified position after setting it away from the already mounted one as shown in this section.
- Keep the cumulative pitch error of the mounting screw holes within  $\pm 0.2$  mm. When two or more secondary sides are mounted, clearance may be left between the secondary sides depending on the mounting method and the number of secondary sides.

When using multiple secondary sides, arrange the caution name plates attached to the product in the same direction to keep the layout of magnetic poles.

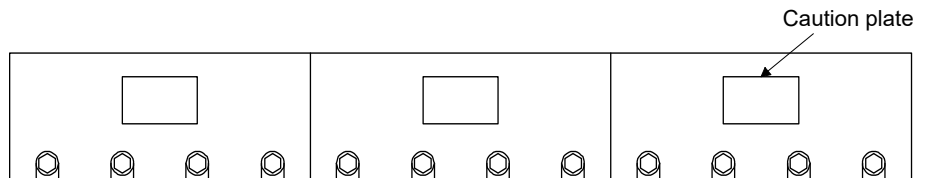

Then, mount them with the following procedure to decrease the clearance between the secondary sides.

Step 1. Securely fix with bolts the secondary side to be a mounting standard.

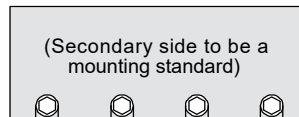

Step 2. Set the secondary side on the mounting face and fix it with bolts as temporary joint.

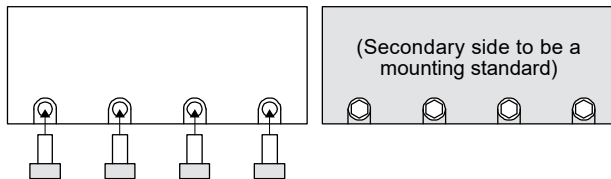

Step 3. Press the secondary side fixed as temporary joint toward that to be a mounting standard.

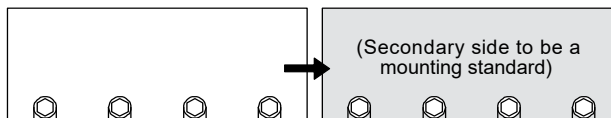

Step 4. Securely fix with bolts the secondary side fixed as temporary joint.

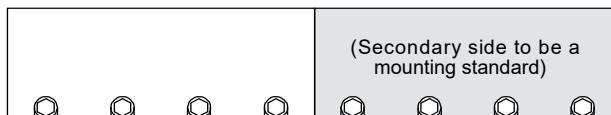

## 5. LINEAR SERVO MOTOR

---

### (3) Installation of the primary side (coil)

Step 1. Mount a part of the secondary side.

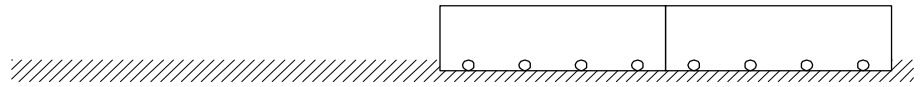

Step 2. Mount the primary side in the position free from the secondary side.

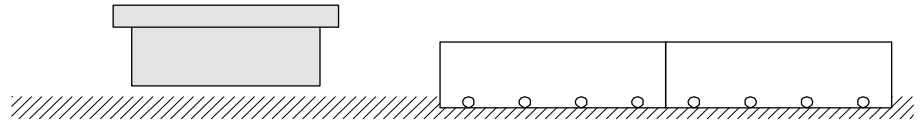

Step 3. Move the primary side over the mounted secondary side.

Confirm that the primary side does not contact the secondary side.

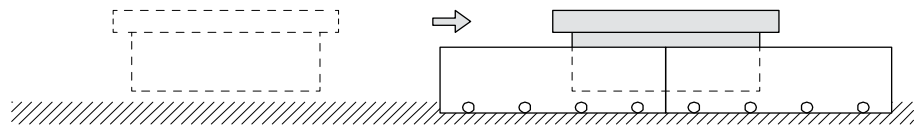

Step 4. Mount the rest of the secondary side.

Confirm that the primary side does not contact the secondary side.

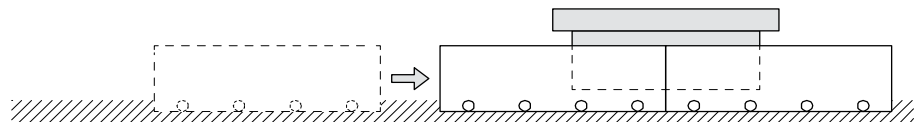



# 5. LINEAR SERVO MOTOR

## (b) LM-U2PAD-10M-0SS0

[Unit: mm]

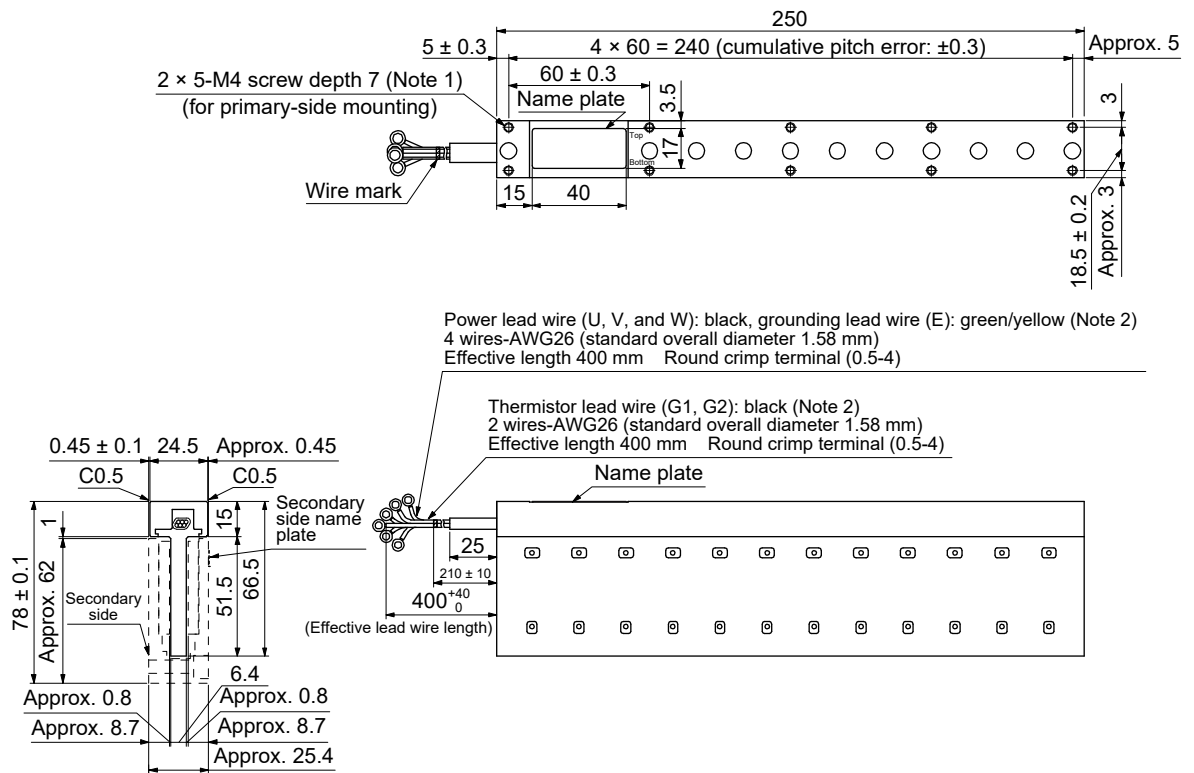

- Note 1. For mounting, use the hexagonal cap head bolt whose material is SUS304, the lower yield point 206 N/mm<sup>2</sup> or equivalent, and fitting screw length 4 mm or more.
- Note 2. This lead wire is for fixed wiring. Securely fix it to the structure. Minimum bending radius of the lead wire is recommended to be six times or more (reference value) the standard overall diameter of the lead wire. Select the cable used for the moving part considering the speed of linear servo motor and the flexing radius.

# 5. LINEAR SERVO MOTOR

(c) LM-U2PAF-15M-0SS0

[Unit: mm]

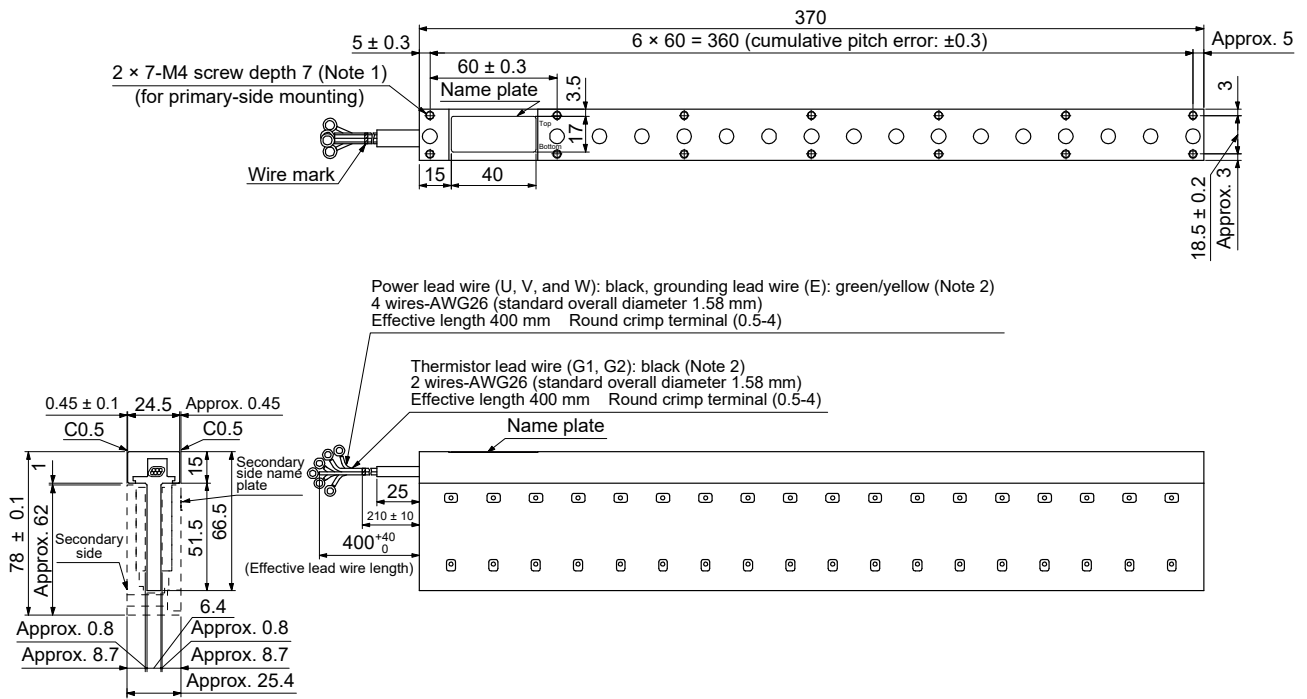

- Note 1. For mounting, use the hexagonal cap head bolt whose material is SUS304, the lower yield point 206 N/mm<sup>2</sup> or equivalent, and fitting screw length 4 mm or more.
- Note 2. This lead wire is for fixed wiring. Securely fix it to the structure. Minimum bending radius of the lead wire is recommended to be six times or more (reference value) the standard overall diameter of the lead wire. Select the cable used for the moving part considering the speed of linear servo motor and the flexing radius.



# 5. LINEAR SERVO MOTOR

(e) LM-U2PBD-15M-1SS0

[Unit: mm]

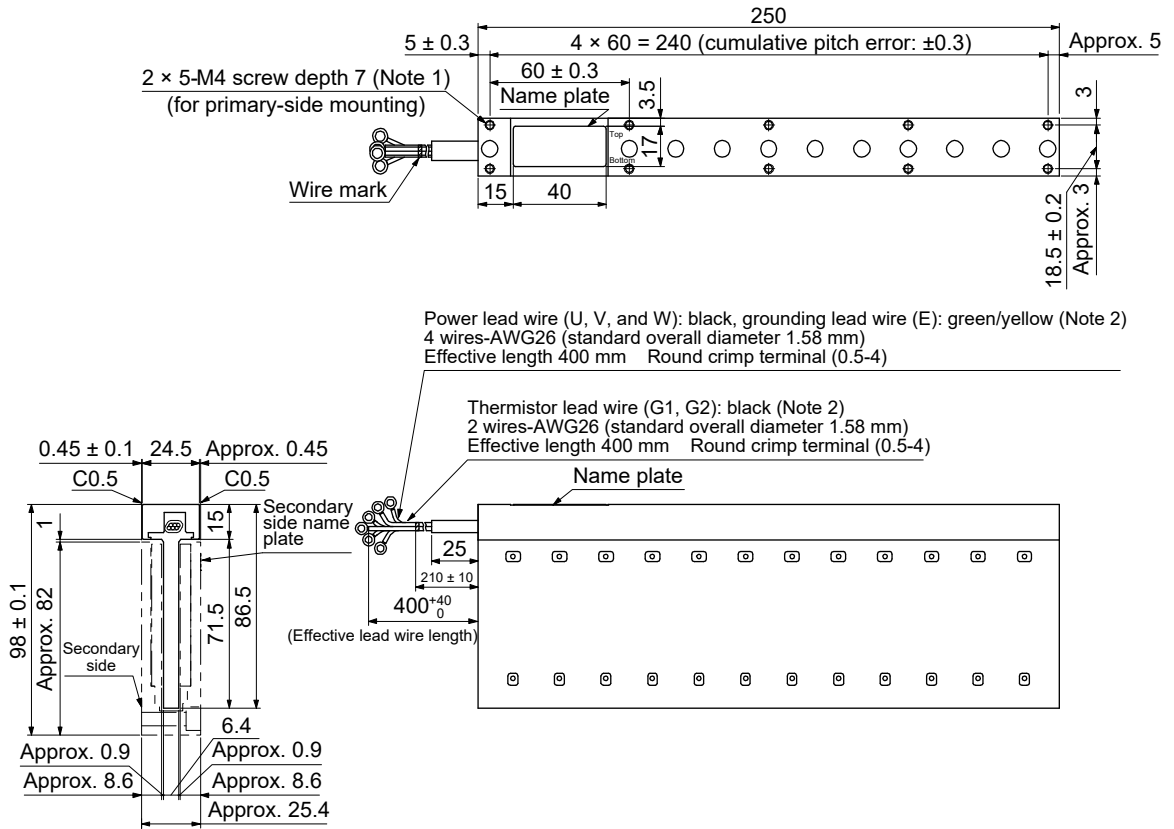

- Note 1. For mounting, use the hexagonal cap head bolt whose material is SUS304, the lower yield point 206 N/mm<sup>2</sup> or equivalent, and fitting screw length 4 mm or more.
- Note 2. This lead wire is for fixed wiring. Securely fix it to the structure. Minimum bending radius of the lead wire is recommended to be six times or more (reference value) the standard overall diameter of the lead wire. Select the cable used for the moving part considering the speed of linear servo motor and the flexing radius.

# 5. LINEAR SERVO MOTOR

## (f) LM-U2PBF-22M-1SS0

[Unit: mm]

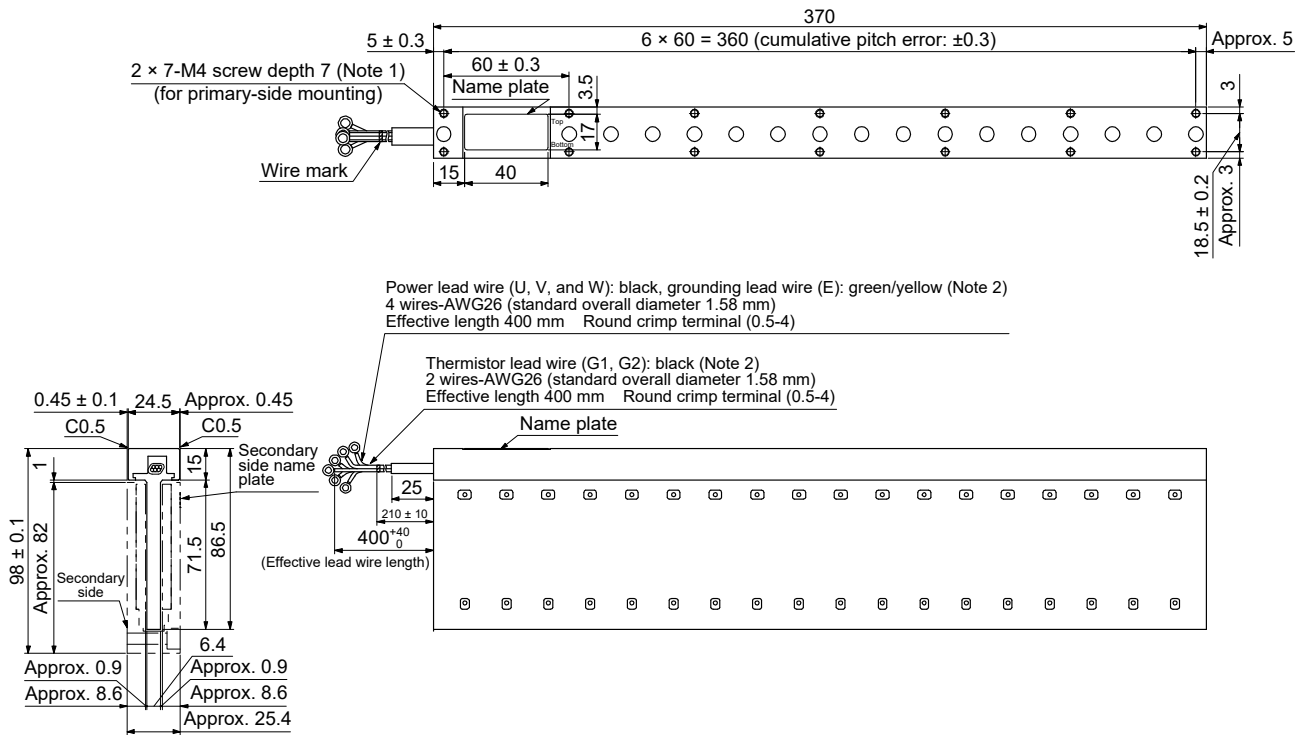

- Note 1. For mounting, use the hexagonal cap head bolt whose material is SUS304, the lower yield point 206 N/mm<sup>2</sup> or equivalent, and fitting screw length 4 mm or more.
- Note 2. This lead wire is for fixed wiring. Securely fix it to the structure. Minimum bending radius of the lead wire is recommended to be six times or more (reference value) the standard overall diameter of the lead wire. Select the cable used for the moving part considering the speed of linear servo motor and the flexing radius.

# 5. LINEAR SERVO MOTOR

(g) LM-U2P2B-40M-2SS0

[Unit: mm]

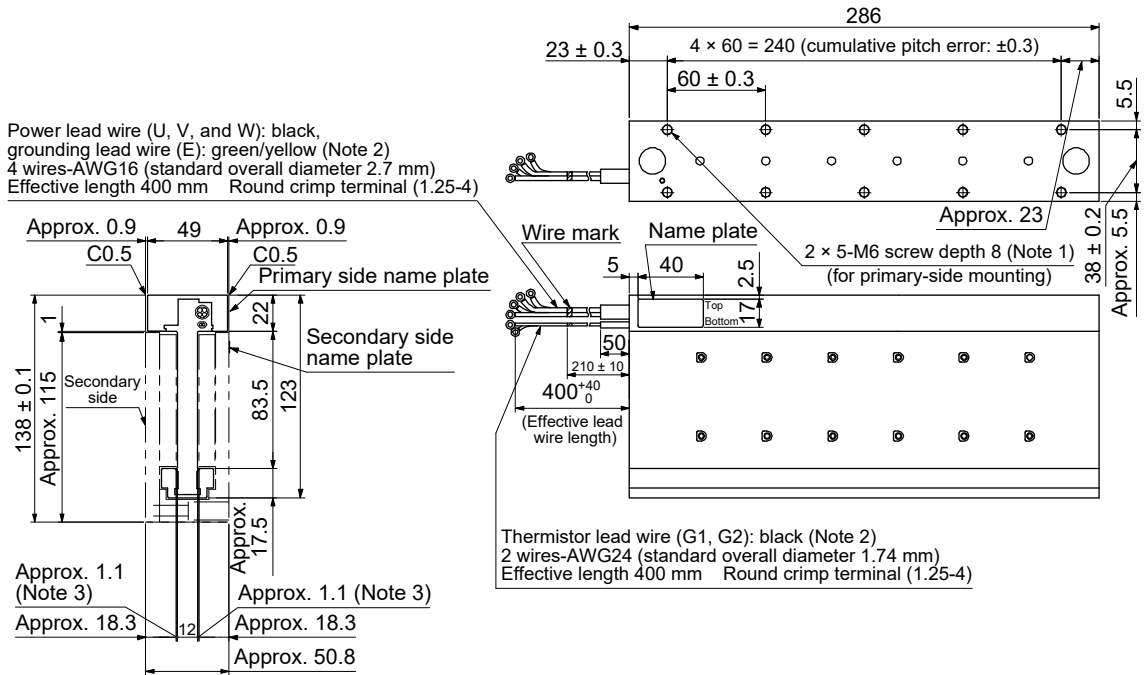

- Note 1. For mounting, use the hexagonal cap head bolt whose material is SUS304, the lower yield point 206 N/mm<sup>2</sup> or equivalent, and fitting screw length 4 mm or more.
- Note 2. This lead wire is for fixed wiring. Securely fix it to the structure. Minimum bending radius of the lead wire is recommended to be six times or more (reference value) the standard overall diameter of the lead wire. Select the cable used for the moving part considering the speed of linear servo motor and the flexing radius.
- Note 3. When mounting the primary side to the secondary side, make adjustment to ensure the gap.



# 5. LINEAR SERVO MOTOR

## (i) LM-U2P2D-80M-2SS0

[Unit: mm]

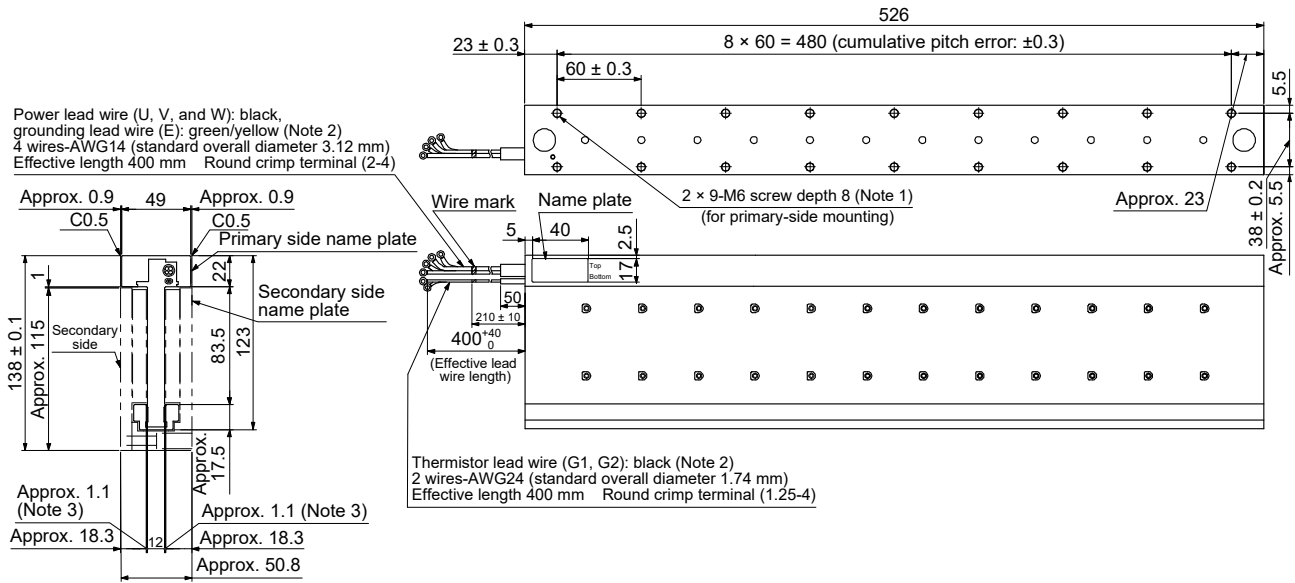

- Note 1. For mounting, use the hexagonal cap head bolt whose material is SUS304, the lower yield point 206 N/mm<sup>2</sup> or equivalent, and fitting screw length 4 mm or more.
- Note 2. This lead wire is for fixed wiring. Securely fix it to the structure. Minimum bending radius of the lead wire is recommended to be six times or more (reference value) the standard overall diameter of the lead wire. Select the cable used for the moving part considering the speed of linear servo motor and the flexing radius.
- Note 3. When mounting the primary side to the secondary side, make adjustment to ensure the gap.

## (2) Secondary side (magnet) (a) LM-U2SA0-240-0SS0

[Unit: mm]

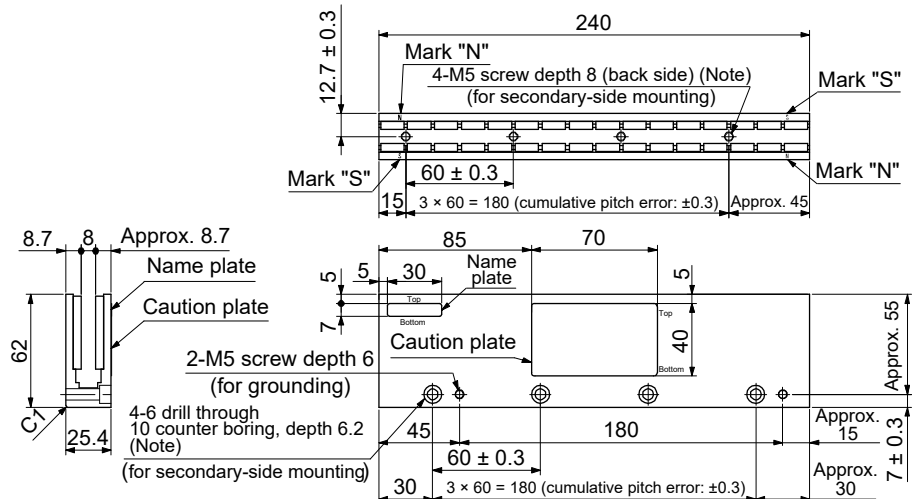

Note. For mounting, use the hexagonal cap head bolt whose material is SUS304 and the lower yield point is 206 N/mm<sup>2</sup> or equivalent.



## 5. LINEAR SERVO MOTOR

(d) LM-U2SB0-240-1SS1

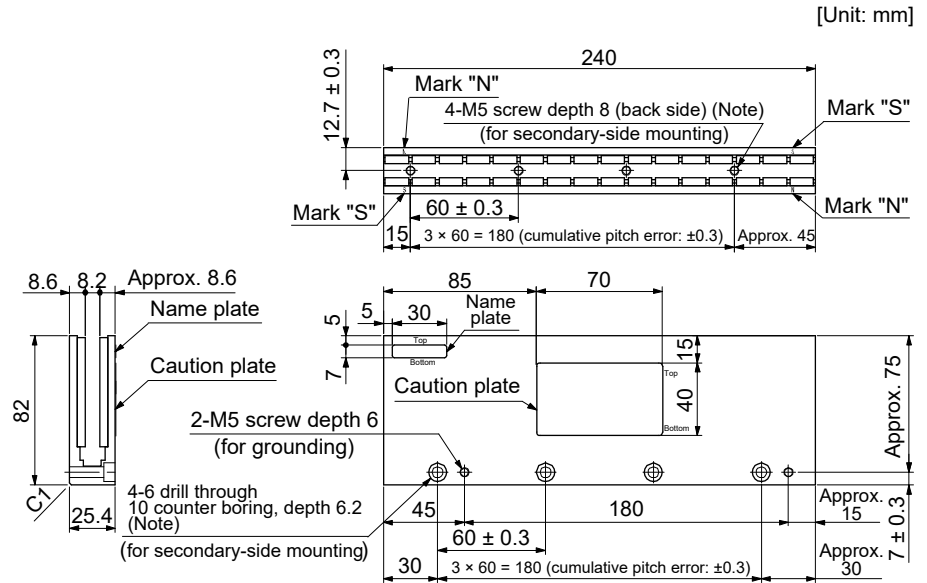

Note. For mounting, use the hexagonal cap head bolt whose material is SUS304 and the lower yield point is 206 N/mm<sup>2</sup> or equivalent.

(e) LM-U2SB0-300-1SS1

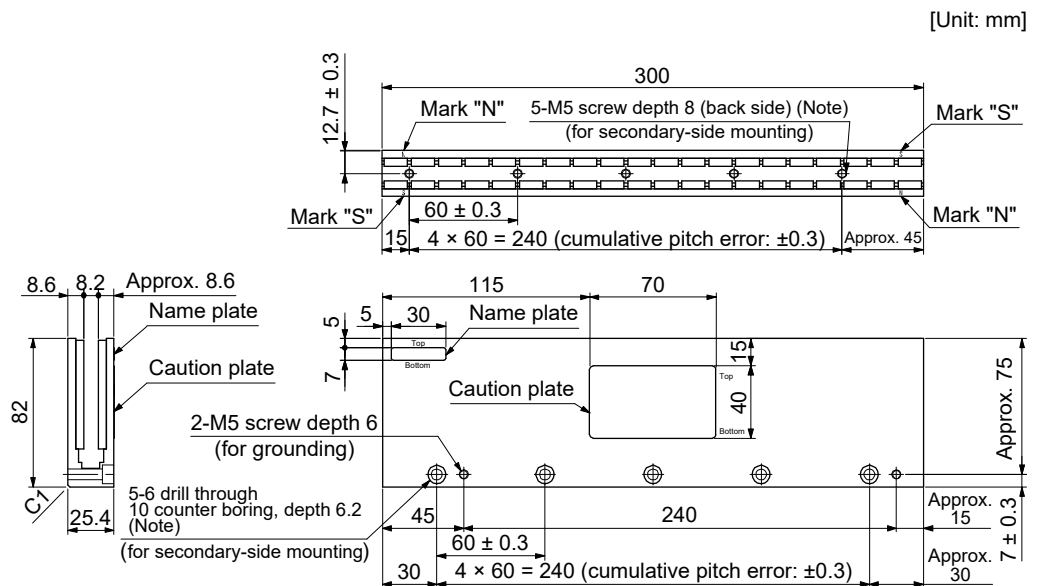

Note. For mounting, use the hexagonal cap head bolt whose material is SUS304 and the lower yield point is 206 N/mm<sup>2</sup> or equivalent.





# 5. LINEAR SERVO MOTOR

## 5.4 LM-F series

### 5.4.1 Model definition

The following describes what each block of a model name indicates. Not all combinations of the symbols are available.

#### (1) Primary side (coil)

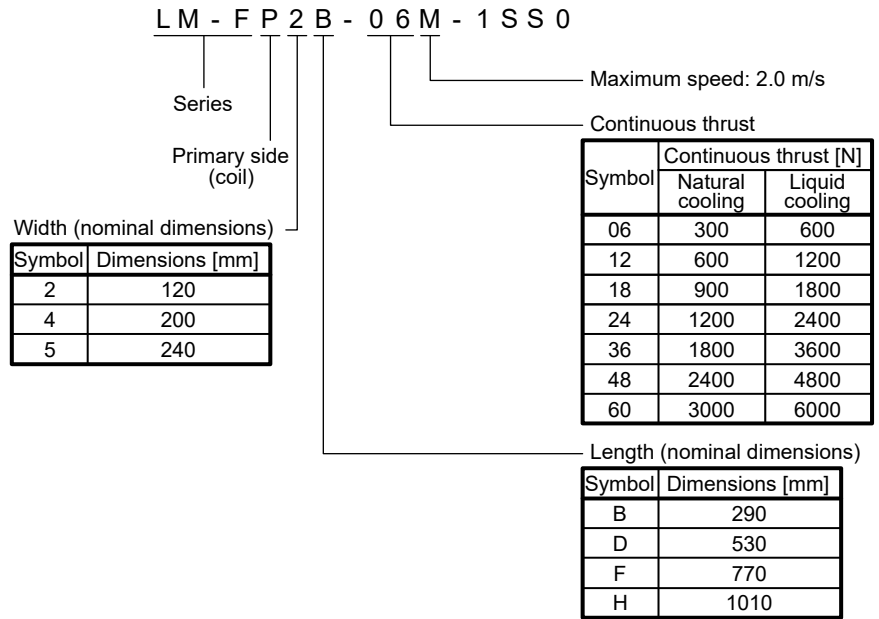

#### (2) Secondary side (magnet)

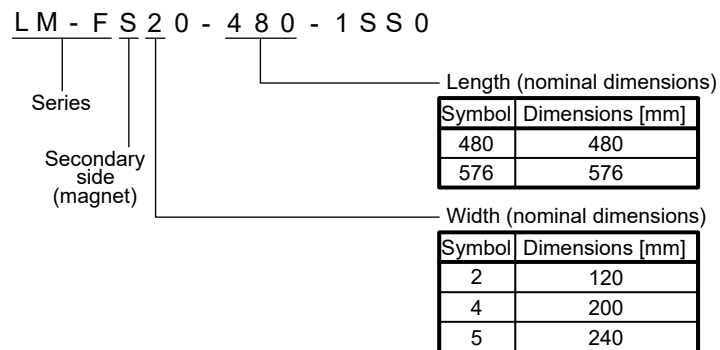

## 5. LINEAR SERVO MOTOR

### 5.4.2 Combinations of servo amplifiers/drive units and linear servo motors

Linear servo motor		Servo amplifiers/ Drive units (Note 1)
Primary side	Secondary side	
LM-FP2B-06M-1SS0	LM-FS20-480-1SS0 LM-FS20-576-1SS0	MR-J4-200A(-RJ) MR-J4-200B(-RJ) MR-J4-200GF(-RJ)
LM-FP2D-12M-1SS0		MR-J4-500A(-RJ) MR-J4-500B(-RJ) MR-J4-500GF(-RJ)
LM-FP2F-18M-1SS0		MR-J4-700A(-RJ) MR-J4-700B(-RJ) MR-J4-700GF(-RJ) MR-J4-DU900B(-RJ)
LM-FP4B-12M-1SS0	LM-FS40-480-1SS0 LM-FS40-576-1SS0	MR-J4-500A(-RJ) MR-J4-500B(-RJ) MR-J4-500GF(-RJ)
LM-FP4D-24M-1SS0		MR-J4-700A(-RJ) MR-J4-700B(-RJ) MR-J4-700GF(-RJ) MR-J4-DU900B(-RJ)
LM-FP4F-36M-1SS0		MR-J4-11KA(-RJ) MR-J4-11KB(-RJ) MR-J4-11KGF(-RJ) MR-J4-DU11KB(-RJ)
LM-FP4H-48M-1SS0		MR-J4-15KA(-RJ) MR-J4-15KB(-RJ) MR-J4-15KGF(-RJ) MR-J4-DU15KB(-RJ)
LM-FP5H-60M-1SS0 (Note 2)	LM-FS50-480-1SS0 LM-FS50-576-1SS0	MR-J4-22KA4(-RJ) MR-J4-22KB4(-RJ) MR-J4-22KGF4(-RJ) MR-J4-DU22KB4(-RJ)

- Note 1. Set [Pr. PA17] and [Pr. PA18] according to the linear servo motor to be used.  
2. Use a 400 V class servo amplifier (drive unit) for this linear servo motor.

## 5. LINEAR SERVO MOTOR

### 5.4.3 LM-F series specification list

Linear servo motor (primary side) LM-F_		P2B-06M-1SS0	P2D-12M-1SS0	P2F-18M-1SS0	P4B-12M-1SS0	P4D-24M-1SS0	P4F-36M-1SS0	P4H-48M-1SS0	P5H-60M-1SS0	
Linear servo motor (secondary side) LM-F_		S20-480-1SS0 S20-576-1SS0			S40-480-1SS0 S40-576-1SS0			S50-480-1SS0 S50-576-1SS0		
Power supply capacity [kVA]		Refer to "USING A LINEAR SERVO MOTOR" in each Servo Amplifier Instruction Manual.								
Cooling method		Natural cooling, liquid cooling								
Thrust	Rated (Note 2, 4) [N]	Natural cooling	300	600	900	600	1200	1800	2400	3000
		Liquid cooling	600	1200	1800	1200	2400	3600	4800	6000
	Maximum [N]	1800	3600	5400	3600	7200	10800	14400	18000	
Maximum speed (Note 1) [m/s]		2.0								
Magnetic attraction force [N]		4500	9000	13500	9000	18000	27000	36000	45000	
Rated current [A]	Natural cooling	4.0	7.8	12	7.8	15	21	28	22	
	Liquid cooling	7.8	16	23	17	31	44	59	45	
Maximum current [A]		30	58	87	57	109	159	212	157	
Recommended load to motor mass ratio		Less than 15 times of mass of linear servo motor primary side								
Thermistor		Built-in								
Insulation class		155 (F)								
Structure		Open (IP rating: IP00 (Note 3))								
Environment	Ambient temperature	Operation	0 °C to 40 °C (non-freezing)							
		Storage	-15 °C to 70 °C (non-freezing)							
	Ambient humidity	Operation	10 %RH to 80 %RH (non-condensing)							
		Storage	10 %RH to 90 %RH (non-condensing)							
	Ambience		Indoors (no direct sunlight) free from corrosive gas, flammable gas, oil mist, dust and dirt.							
	Altitude		1000 m or less above sea level							
Vibration resistance		49 m/s <sup>2</sup>								
Mass	Primary side [kg]	9.0	18	27	14	28	42	56	67	
	Secondary side [kg]	7.0 (480 mm one magnet) 9.0 (576 mm one magnet)			12 (480 mm one magnet) 15 (576 mm one magnet)			20 (480 mm one magnet) 24 (576 mm one magnet)		

- Note 1. The maximum speed of linear servo motor is the smaller value of the maximum speed of linear servo motor and the rated speed of linear encoder.
2. The indicated value is when the aluminum board with the following dimensions (L [mm] × W [mm] × H [mm]) is mounted on the primary side. (reference value)
- LM-FP2B-06M-1SS0: 280 × 250 × 50
  - LM-FP2D-12M-1SS0: 510 × 250 × 50
  - LM-FP2F-18M-1SS0: 740 × 250 × 50
  - LM-FP4B-12M-1SS0: 280 × 425 × 50
  - LM-FP4D-24M-1SS0: 500 × 425 × 50
  - LM-FP4F-36M-1SS0: 730 × 425 × 50
  - LM-FP4H-48M-1SS0: 960 × 425 × 50
  - LM-FP5H-60M-1SS0: 1030 × 470 × 50
3. IP classifies the degrees of protection provided against the intrusion of solid objects and water in electrical enclosures.
4. Use the linear servo motor with 70% or less of the effective load ratio when it is in the servo lock state or in a small reciprocating motion.

## 5. LINEAR SERVO MOTOR

### 5.4.4 Thrust characteristics

For the LM-FP5H-60M-1SS0, the continuous line indicates the thrust characteristic when the input power supply specification of the servo amplifier is 3-phase 400 V AC. For other linear servo motors, the continuous line indicates the thrust characteristic when the input power supply specification of the servo amplifier is 3-phase 200 V AC and 1-phase 200 V AC.

The continuous/max. thrust and max. speed of the linear servo motor are in the case of the rated power voltage and frequency of the combined servo amplifier.

#### (1) 3-phase 200 V AC and 3-phase 400 V AC

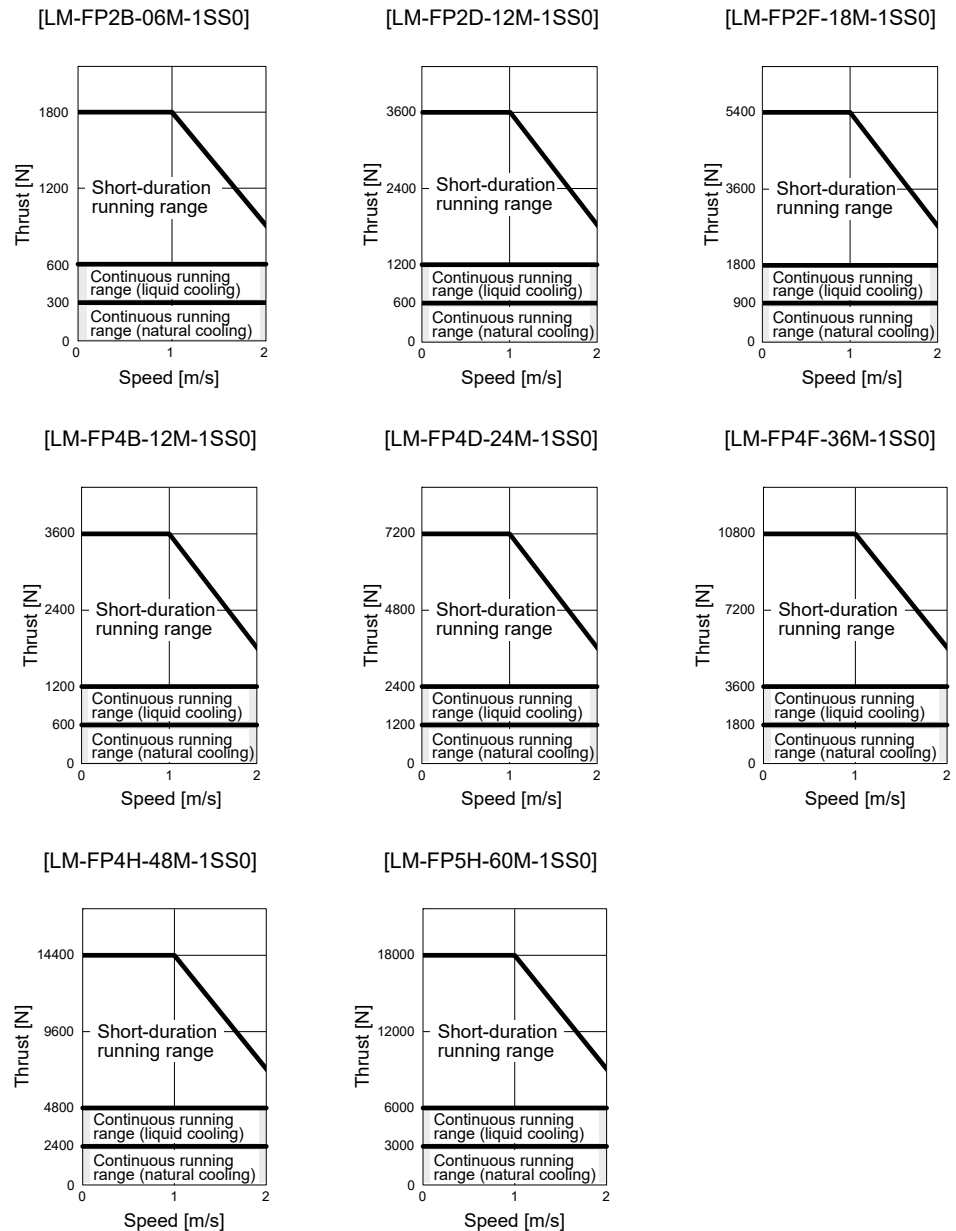

## 5. LINEAR SERVO MOTOR

(2) 1-phase 200 V AC

[LM-FP2B-06M-1SS0]

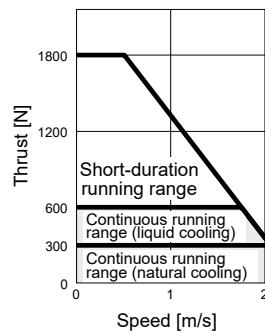

### 5.4.5 Installation

(1) Installation procedure

[Unit: mm]

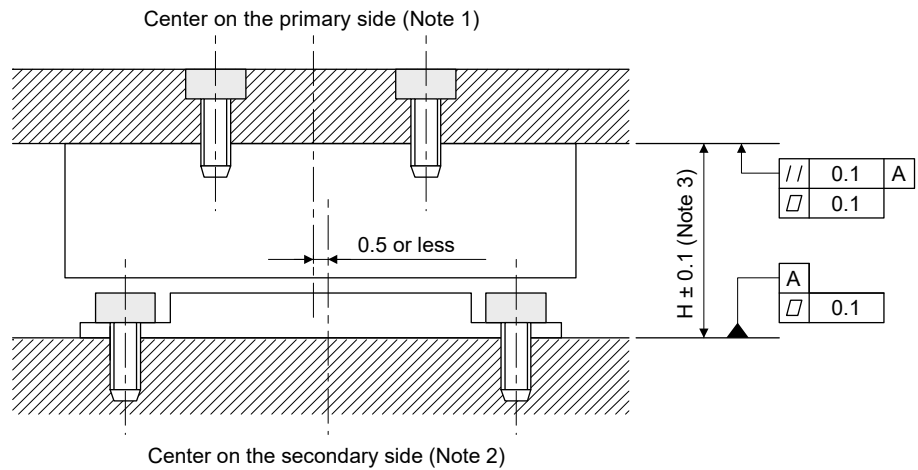

Note 1. Centers on the primary side are as follows.

LM-FP2\_-M-1SS0: Center of mounting screw pitch

LM-FP4\_-M-1SS0: Center mounting screw position

LM-FP5H-60M-1SS0: Center of mounting screw pitch

Note 2. Centers on the secondary side is the center of mounting screw pitch.

Note 3. H length indicates (height of primary side) + (height of secondary side) + (length of empty clearance: 0.5 mm).

LM-FP2\_-M-1SS0: H = 70 mm

LM-FP4\_-M-1SS0: H = 70 mm

LM-FP5H-60M-1SS0: H = 75.5 mm

## 5. LINEAR SERVO MOTOR

### (2) Installation of the secondary side (magnet)



**WARNING**

- The permanent magnet on the secondary side makes the magnetic bodies generate attraction force. Be careful not to get your hand stuck.



**CAUTION**

- When mounting the secondary side, use nonmagnetic tools.
- When the additional secondary side is mounted after one has been already set, slide the additional secondary side to mount it in its specified position after setting it away from the already mounted one as shown in this section.
- Keep the cumulative pitch error of the mounting screw holes within  $\pm 0.2$  mm. When two or more secondary sides are mounted, clearance may be left between the secondary sides depending on the mounting method and the number of secondary sides.

When using multiple secondary sides, arrange the name plates attached to the product in the same direction to keep the layout of magnetic poles.

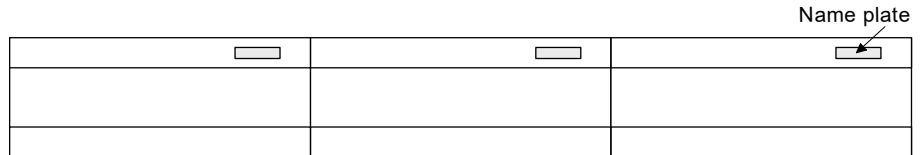

Then, mount them with the following procedure to decrease the clearance between the secondary sides.

Step 1. Securely fix with bolts the secondary side to be a mounting standard.

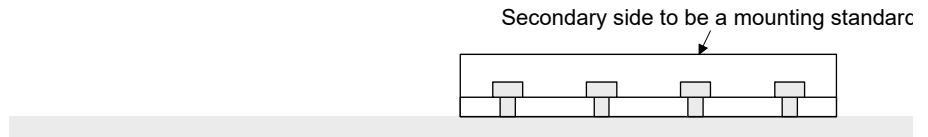

Step 2. Set the secondary side on the mounting face and fix it with bolts as temporary joint.

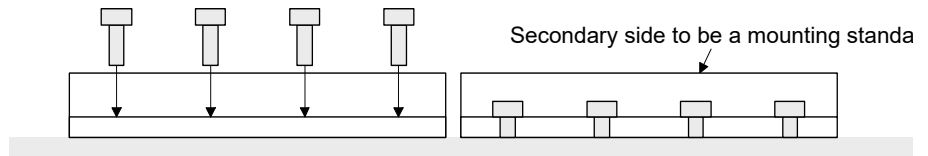

Step 3. Press the secondary side fixed as temporary joint toward that to be a mounting standard.

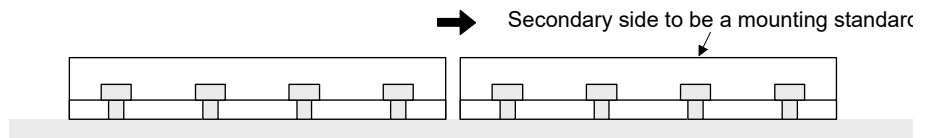

Step 4. Securely fix with bolts the secondary side fixed as temporary joint.

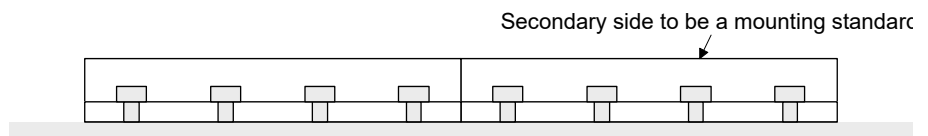

## 5. LINEAR SERVO MOTOR

---

### (3) Installation of the primary side (coil)



#### CAUTION

- To avoid the danger caused by attraction force generated between the primary side and the secondary side by the permanent magnet, it is recommended to install the primary side in the position free from the secondary side as shown in this section.
- When mounting the primary side over the secondary side unavoidably, use the material handling equipment such as crane which is fully competent to sustain the load of attraction force, etc.
- When sliding the primary side to move over the secondary side after setting, pay full attention to the attraction force generated.

Step 1. Mount a part of the secondary side.

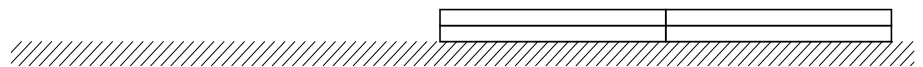

Step 2. Mount the primary side in the position free from the secondary side.

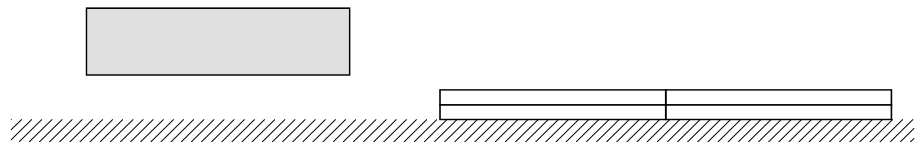

Step 3. Move the primary side over the mounted secondary side.  
Confirm that the primary side does not contact the secondary side.

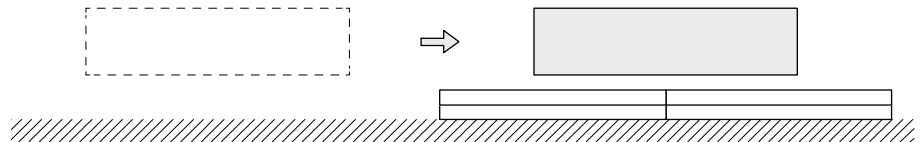

Step 4. Mount the rest of the secondary side.  
Confirm that the primary side does not contact the secondary side.

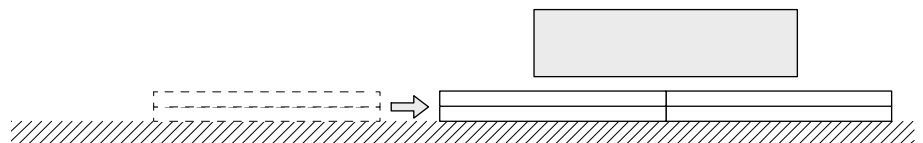

## 5. LINEAR SERVO MOTOR

---

### 5.4.6 Liquid cooling

LM-F series linear servo motor is compatible with liquid cooling. Configure the machine (system) after checking the followings.

- (1) Parts required for cooling system design, including the cooling pipe laying in the table of primary side, parts required for installation and cooling, cooling machine (chiller), and coolant should be selected by the customer.  
For example, when water is used as coolant, 5 liter or more is required per minute.  
Keep the pressure on the pipe flow entrance to be 0.5 MPa or less.
- (2) To prevent any foreign matter from entering into the cooling pipe, be sure to always set the filter, etc. in the flow path.
- (3) To avoid liquid leak, pipe laying for cooling and joint should be selected by the customer. Especially, select the cooling pipe which stands the flexing action.
- (4) It is recommended to keep the liquid temperature injected into the cooling pipe around 20 °C. Although high cooling effect may be obtained by lowering the liquid temperature, be careful about the dew condensation.
- (5) Since the overload protection characteristics is different from that for natural cooling, check if the condition such as operation pattern is matched with the overload protection characteristics. If the operation pattern is not matched with the overload protection characteristics, an alarm may occur. For the overload protection characteristics, refer to each servo amplifier instruction manual.
- (6) As the material for cooling pipe is copper, select the rust preventive material which does not corrode the copper.
- (7) When laying the cooling pipe, fix the hexagon part of cooling pipe with spanner. Tightening torque should be 3.0 N•m to 3.5 N•m.

# 5. LINEAR SERVO MOTOR

## 5.4.7 Dimensions

- (1) Primary side (coil)
  - (a) LM-FP2B-06M-1SS0

[Unit: mm]

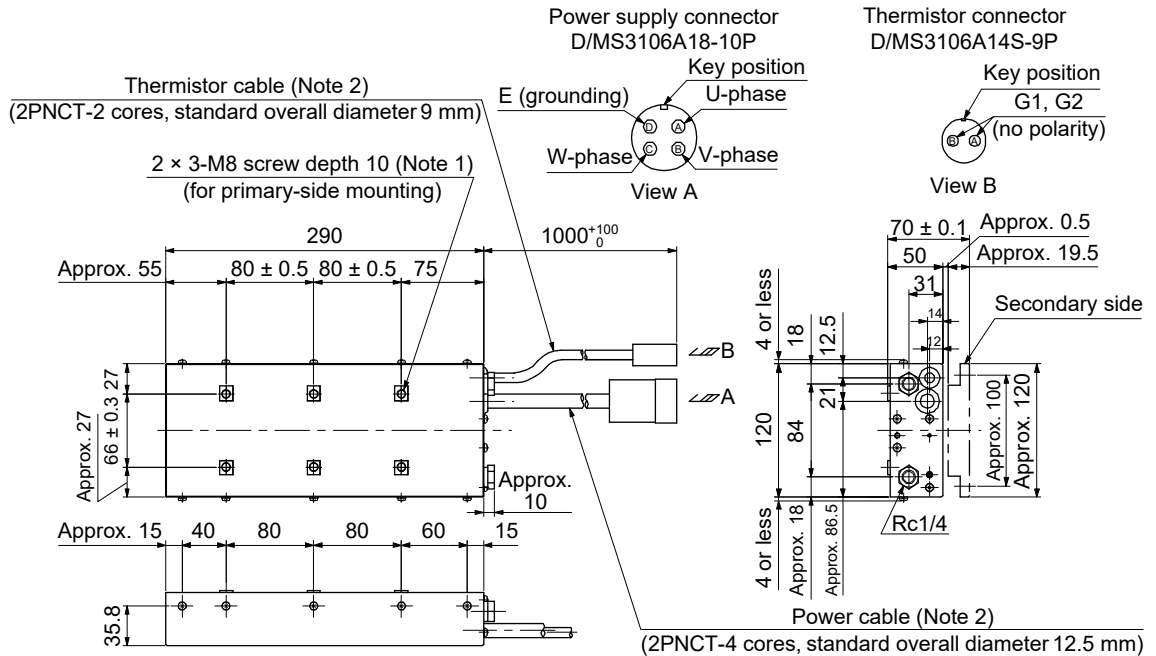

- Note 1. For mounting, use the hexagonal cap head bolt whose strength must be a high tensile strength steel level of SCM435 for its material, and the lower yield point is 900 N/mm<sup>2</sup> or equivalent.
- Note 2. This cable is for fixed wiring. Securely fix it to the structure. Minimum bending radius of the cable is recommended to be six times or more (reference value) the standard overall diameter of the cable. Select the cable used for the moving part considering the speed of linear servo motor and the flexing radius.

# 5. LINEAR SERVO MOTOR

(b) LM-FP2D-12M-1SS0

[Unit: mm]

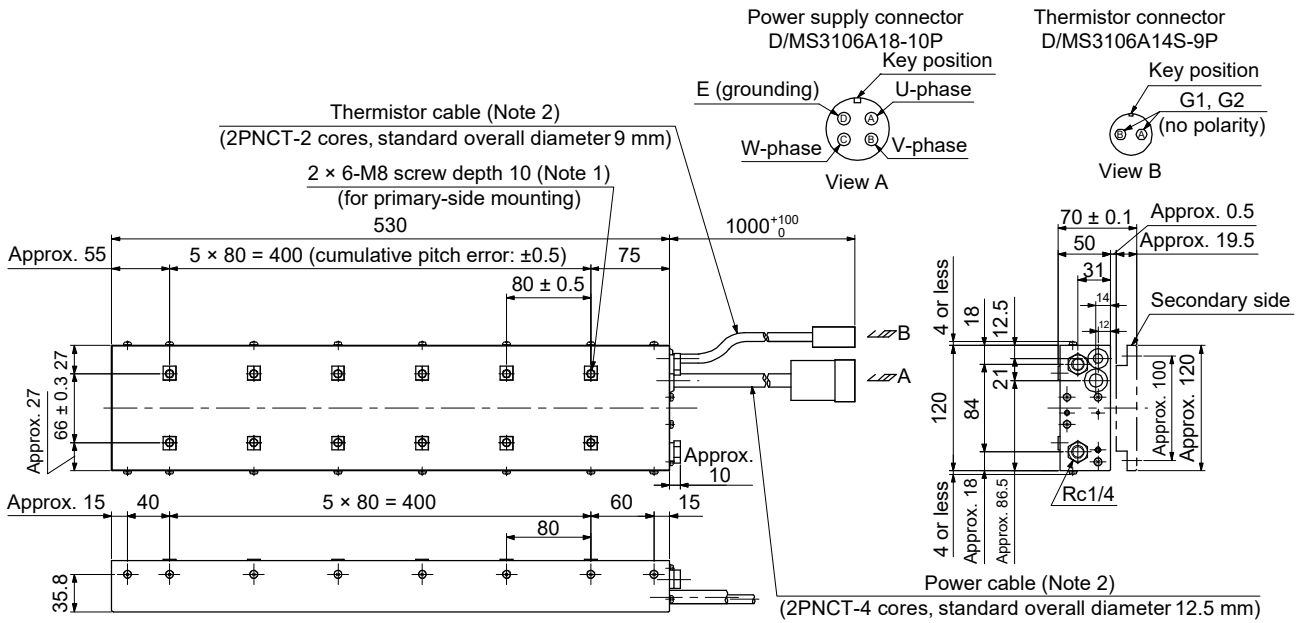

- Note 1. For mounting, use the hexagonal cap head bolt whose strength must be a high tensile strength steel level of SCM435 for its material, and the lower yield point is 900 N/mm<sup>2</sup> or equivalent.
- Note 2. This cable is for fixed wiring. Securely fix it to the structure. Minimum bending radius of the cable is recommended to be six times or more (reference value) the standard overall diameter of the cable. Select the cable used for the moving part considering the speed of linear servo motor and the flexing radius.

# 5. LINEAR SERVO MOTOR

(c) LM-FP2F-18M-1SS0

[Unit: mm]

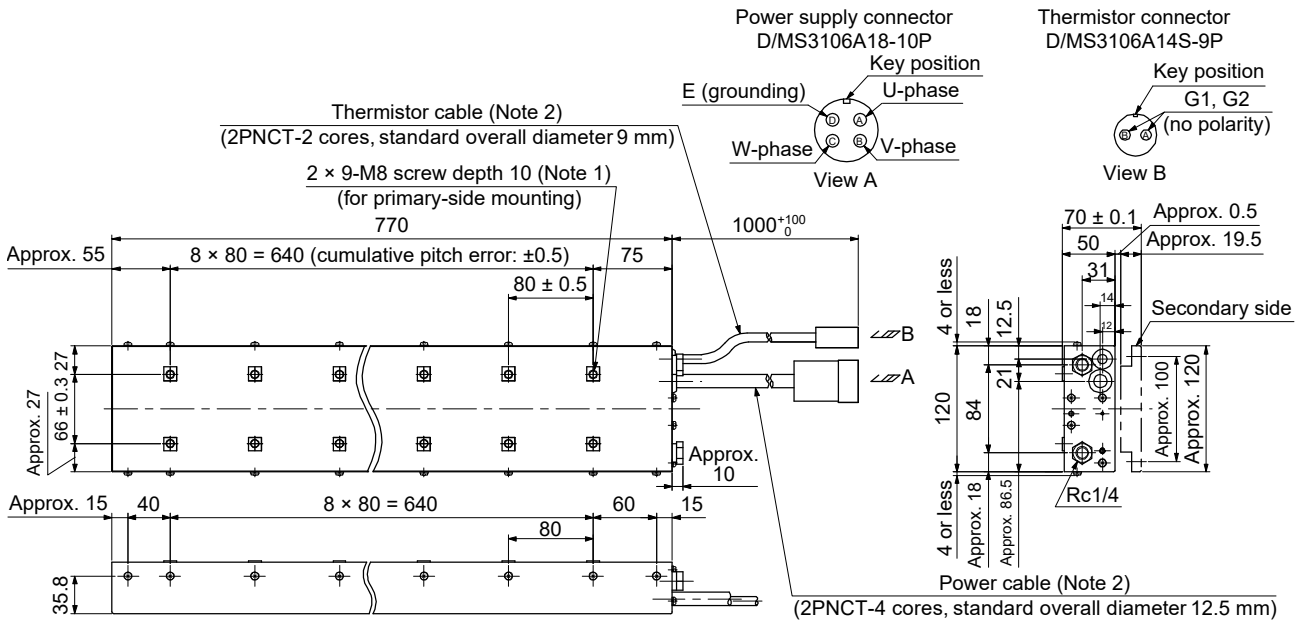

- Note 1. For mounting, use the hexagonal cap head bolt whose strength must be a high tensile strength steel level of SCM435 for its material, and the lower yield point is 900 N/mm<sup>2</sup> or equivalent.
- Note 2. This cable is for fixed wiring. Securely fix it to the structure. Minimum bending radius of the cable is recommended to be six times or more (reference value) the standard overall diameter of the cable. Select the cable used for the moving part considering the speed of linear servo motor and the flexing radius.





## 5. LINEAR SERVO MOTOR

(f) LM-FP4F-36M-1SS0

[Unit: mm]

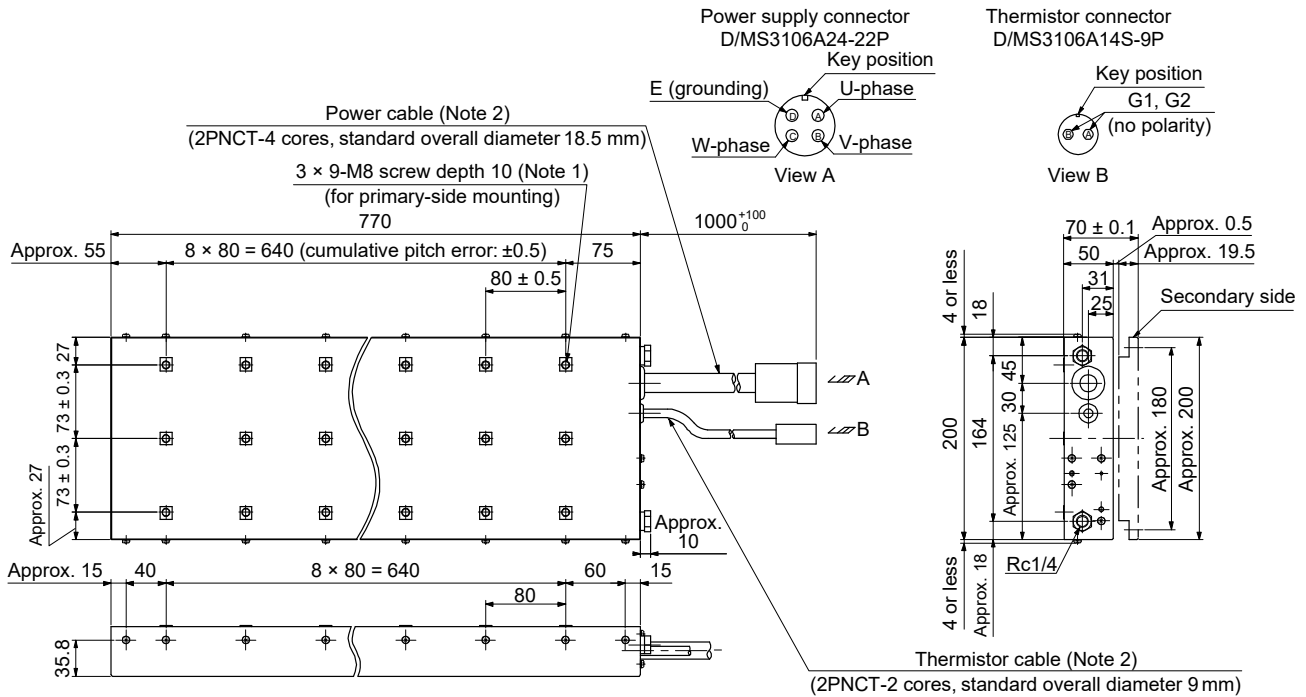

- Note 1. For mounting, use the hexagonal cap head bolt whose material is SCM435 and the lower yield point is 900 N/mm<sup>2</sup> or equivalent.
- Note 2. This cable is for fixed wiring. Securely fix it to the structure. Minimum bending radius of the cable is recommended to be six times or more (reference value) the standard overall diameter of the cable. Select the cable used for the moving part considering the speed of linear servo motor and the flexing radius.

# 5. LINEAR SERVO MOTOR

(g) LM-FP4H-48M-1SS0

[Unit: mm]

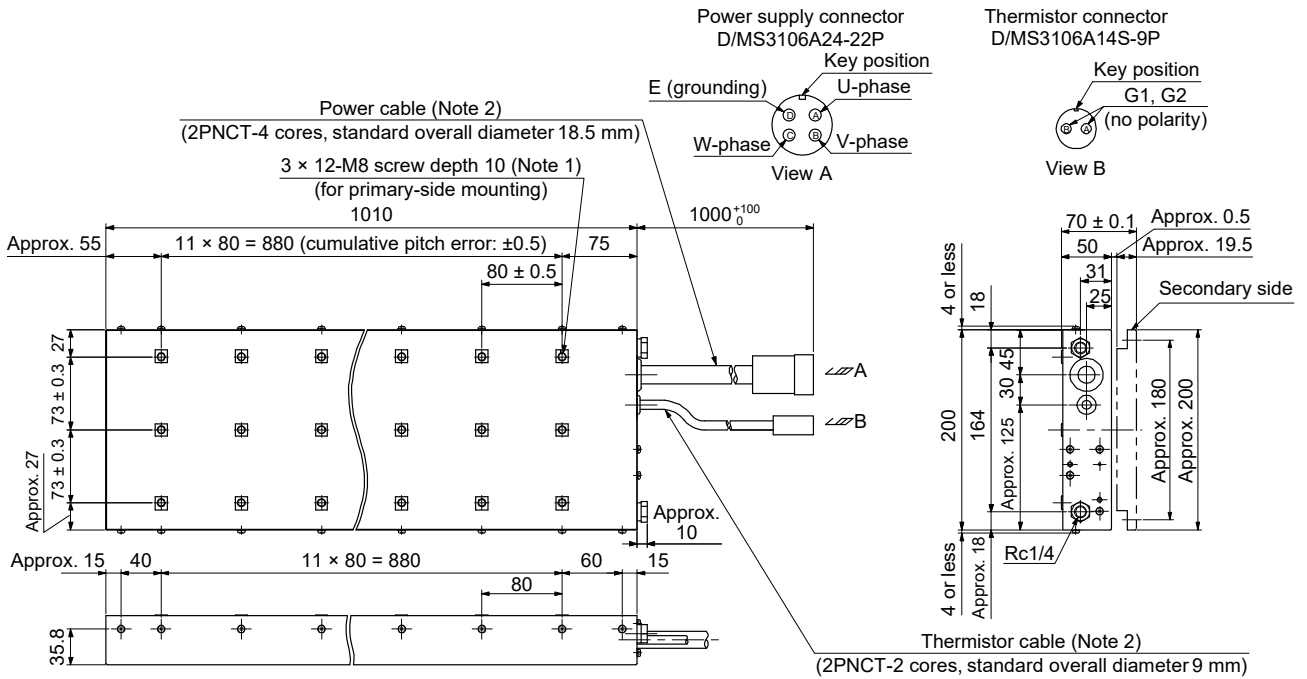

- Note 1. For mounting, use the hexagonal cap head bolt whose material is SCM435 and the lower yield point is 900 N/mm<sup>2</sup> or equivalent.
- Note 2. This cable is for fixed wiring. Securely fix it to the structure. Minimum bending radius of the cable is recommended to be six times or more (reference value) the standard overall diameter of the cable. Select the cable used for the moving part considering the speed of linear servo motor and the flexing radius.



## 5. LINEAR SERVO MOTOR

- (2) Secondary side (magnet)  
 (a) LM-FS20-\_-1SS0

[Unit: mm]

Model	Variable dimensions			
	L	M	K	B
LM-FS20-480-1SS0	480	4 × 96 = 384	432	2 × 5
LM-FS20-576-1SS0	576	5 × 96 = 480	528	2 × 6

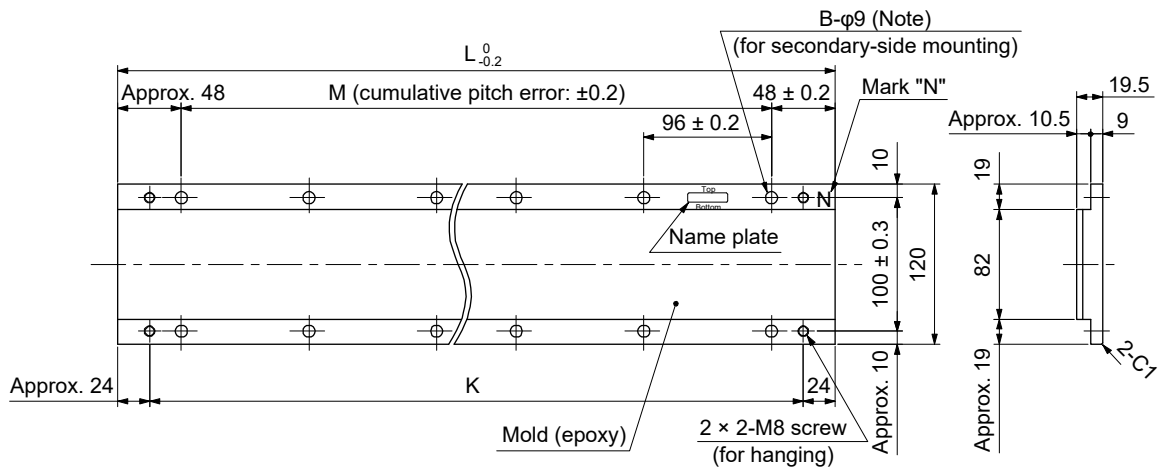

Note. For mounting, use the hexagonal cap head bolt whose material is SCM435 and the lower yield point is 900 N/mm<sup>2</sup> or equivalent.

- (b) LM-FS40-\_-1SS0

[Unit: mm]

Model	Variable dimensions			
	L	M	K	B
LM-FS40-480-1SS0	480	4 × 96 = 384	432	2 × 5
LM-FS40-576-1SS0	576	5 × 96 = 480	528	2 × 6

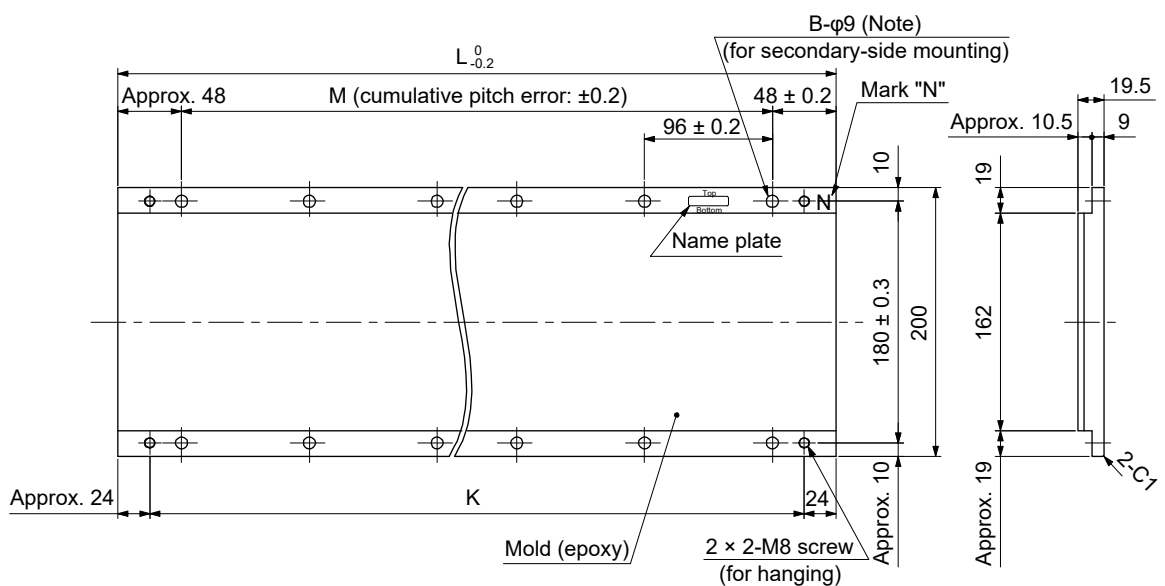

Note. For mounting, use the hexagonal cap head bolt whose material is SCM435 and the lower yield point is 900 N/mm<sup>2</sup> or equivalent.

# 5. LINEAR SERVO MOTOR

(c) LM-FS50-\_-1SS0

[Unit: mm]

Model	Variable dimensions			
	L	M	K	B
LM-FS50-480-1SS0	480	4 × 96 = 384	432	2 × 5
LM-FS50-576-1SS0	576	5 × 96 = 480	528	2 × 6

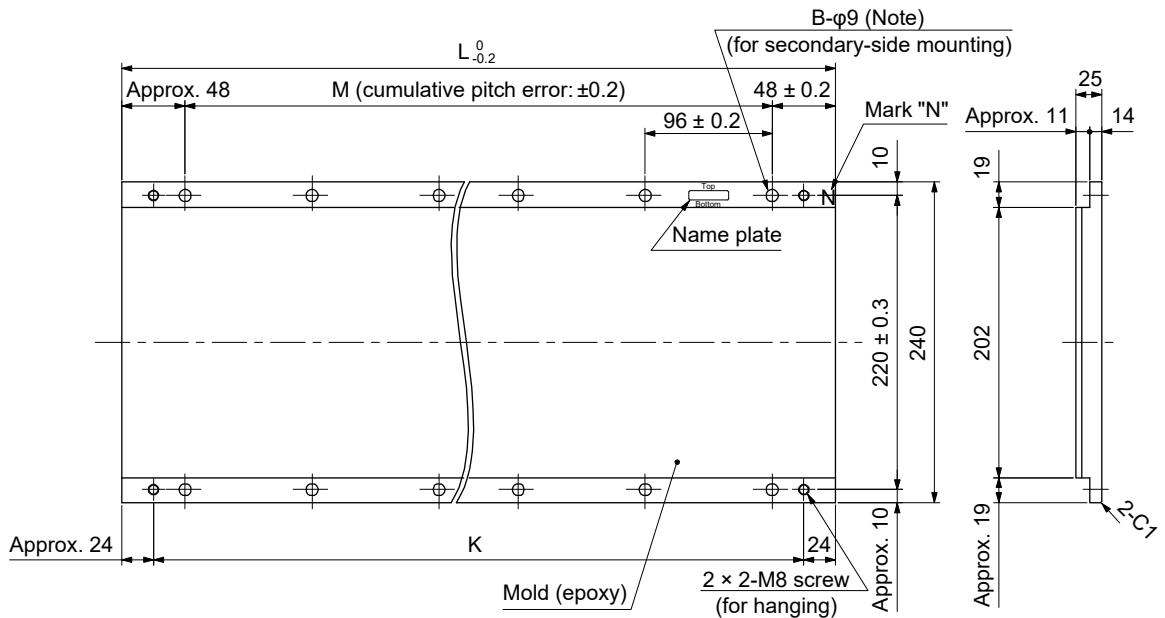

Note. For mounting, use the hexagonal cap head bolt whose material is SCM435 and the lower yield point is 900 N/mm<sup>2</sup> or equivalent.

## 5. LINEAR SERVO MOTOR

### 5.5 LM-K2 series

#### 5.5.1 Model definition

The following describes what each block of a model name indicates. Not all combinations of the symbols are available.

#### (1) Primary side (coil)

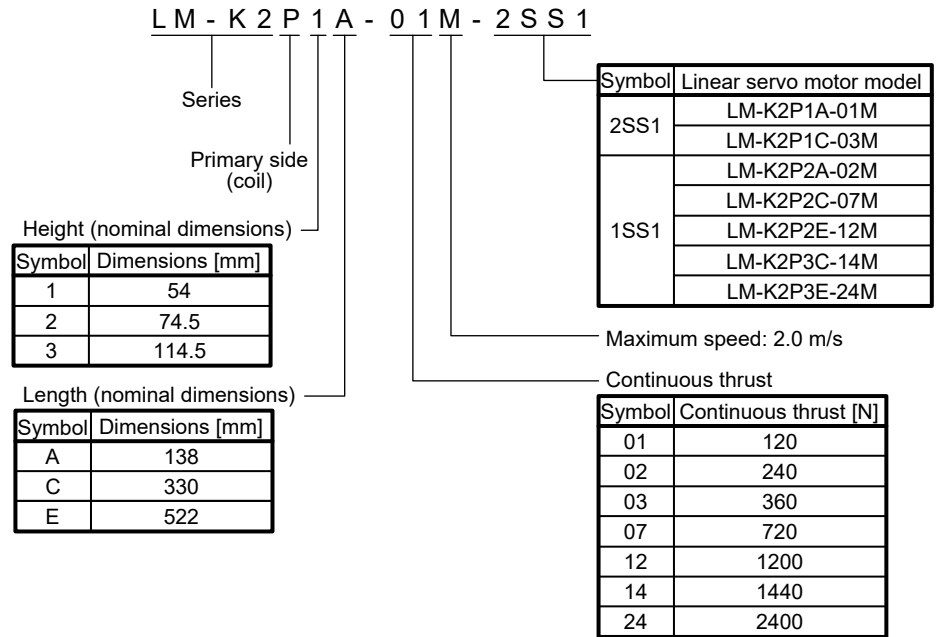

#### (2) Secondary side (magnet)

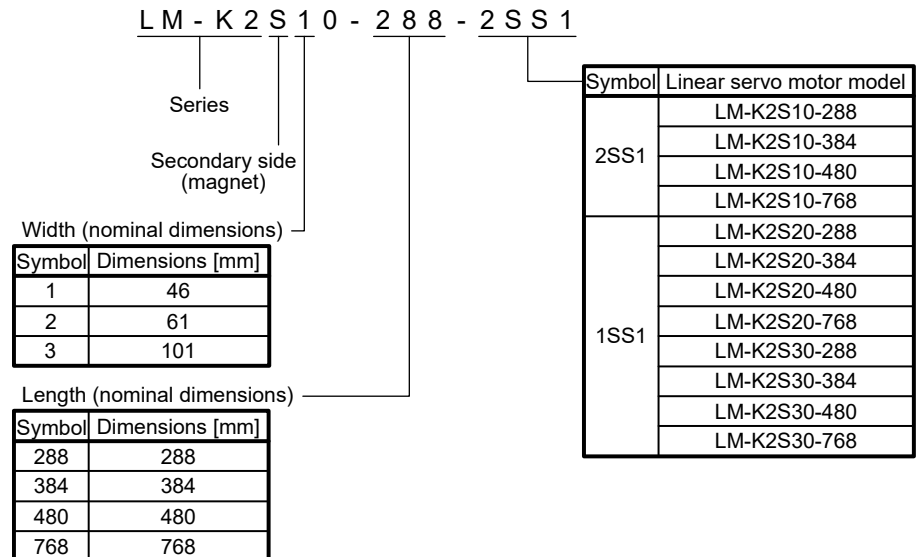

## 5. LINEAR SERVO MOTOR

### 5.5.2 Combinations of servo amplifiers and linear servo motors

POINT
<p>● Rotary servo motors, linear servo motors, and direct drive motors of any series and capacity can be used together if they are compatible with the MR-J4W_ _B servo amplifier.</p>

Linear servo motor		Servo amplifier (Note)
Primary side	Secondary side	
LM-K2P1A-01M-2SS1	LM-K2S10-288-2SS1 LM-K2S10-384-2SS1 LM-K2S10-480-2SS1 LM-K2S10-768-2SS1	MR-J4-40A(1)(-RJ) MR-J4-40B(1)(-RJ) MR-J4W2-44B MR-J4W2-77B MR-J4W2-1010B MR-J4W3-444B MR-J4-40GF(-RJ)
LM-K2P1C-03M-2SS1		MR-J4-200A(-RJ) MR-J4-200B(-RJ) MR-J4-200GF(-RJ)
LM-K2P2A-02M-1SS1	LM-K2S20-288-1SS1 LM-K2S20-384-1SS1 LM-K2S20-480-1SS1 LM-K2S20-768-1SS1	MR-J4-70A(-RJ) MR-J4-70B(-RJ) MR-J4W2-77B MR-J4W2-1010B MR-J4-70GF(-RJ)
LM-K2P2C-07M-1SS1		MR-J4-350A(-RJ) MR-J4-350B(-RJ) MR-J4-350GF(-RJ)
LM-K2P2E-12M-1SS1		MR-J4-500A(-RJ) MR-J4-500B(-RJ) MR-J4-500GF(-RJ)
LM-K2P3C-14M-1SS1	LM-K2S30-288-1SS1 LM-K2S30-384-1SS1 LM-K2S30-480-1SS1 LM-K2S30-768-1SS1	MR-J4-350A(-RJ) MR-J4-350B(-RJ) MR-J4-350GF(-RJ)
LM-K2P3E-24M-1SS1		MR-J4-500A(-RJ) MR-J4-500B(-RJ) MR-J4-500GF(-RJ)

Note. Set [Pr. PA17] and [Pr. PA18] according to the linear servo motor to be used.

## 5. LINEAR SERVO MOTOR

### 5.5.3 LM-K2 series specification list

Linear servo motor (primary side) LM-K2_		P1A-01M-2SS1	P1C-03M-2SS1	P2A-02M-1SS1	P2C-07M-1SS1	P2E-12M-1SS1	P3C-14M-1SS1	P3E-24M-1SS1
Linear servo motor (secondary side) LM-K2_		S10-288-2SS1 S10-384-2SS1 S10-480-2SS1 S10-768-2SS1			S20-288-1SS1 S20-384-1SS1 S20-480-1SS1 S20-768-1SS1		S30-288-1SS1 S30-384-1SS1 S30-480-1SS1 S30-768-1SS1	
Power supply capacity [kVA]		Refer to "USING A LINEAR SERVO MOTOR" in each Servo Amplifier Instruction Manual.						
Cooling method		Natural cooling						
Thrust	Rated (Note 2, 4) [N]	120	360	240	720	1200	1440	2400
	Maximum [N]	300	900	600	1800	3000	3600	6000
Maximum speed (Note 1) [m/s]		2.0						
Magnetic attraction force (Note 5) [N]		0						
Magnetic attraction force (one side) (Note 6) [N]		800	2400	1100	3200	5300	6400	10700
Rated current [A]		2.3	6.8	3.7	12	19	15	25
Maximum current [A]		7.6	23	13	39	65	47	79
Recommended load to motor mass ratio		Less than 30 times of mass of linear servo motor primary side						
Thermistor		Built-in						
Insulation class		155 (F)						
Structure		Open (IP rating: IP00 (Note 3))						
Environment	Ambient temperature	Operation	0 °C to 40 °C (non-freezing)					
		Storage	-15 °C to 70 °C (non-freezing)					
	Ambient humidity	Operation	10 %RH to 80 %RH (non-condensing)					
		Storage	10 %RH to 90 %RH (non-condensing)					
	Ambience		Indoors (no direct sunlight) free from corrosive gas, flammable gas, oil mist, dust and dirt.					
	Altitude		1000 m or less above sea level					
Vibration resistance		49 m/s <sup>2</sup>						
Mass	Primary side [kg]	2.5	6.5	4.0	10	16	18	27
	Secondary side [kg]	1.5 (288 mm one magnet)		1.9 (288 mm one magnet)			5.5 (288 mm one magnet)	
		2.0 (384 mm one magnet)		2.5 (384 mm one magnet)			7.3 (384 mm one magnet)	
		2.5 (480 mm one magnet)		3.2 (480 mm one magnet)			9.2 (480 mm one magnet)	
3.9 (768 mm one magnet)		5.0 (768 mm one magnet)			14.6 (768 mm one magnet)			

- Note
- The maximum speed of linear servo motor is the smaller value of the maximum speed of linear servo motor and the rated speed of linear encoder.
  - The indicated value is when the aluminum board with the following dimensions (L [mm] × W [mm] × H [mm]) is mounted on the primary side. (reference value)  
 LM-K2P1A-01M-1SS1: 375 × 270 × 20  
 LM-K2P1C-03M-1SS1: 375 × 270 × 20  
 LM-K2P2A-02M-1SS1: 375 × 270 × 20  
 LM-K2P2C-07M-1SS1: 375 × 270 × 20  
 LM-K2P2E-12M-1SS1: 520 × 270 × 20  
 LM-K2P3C-14M-1SS1: 375 × 270 × 20  
 LM-K2P3E-24M-1SS1: 760 × 610 × 50
  - IP classifies the degrees of protection provided against the intrusion of solid objects and water in electrical enclosures.
  - Use the linear servo motor with 70% or less of the effective load ratio when it is in the servo lock state or in a small reciprocating motion.
  - Magnetic attraction force will be generated due to assembly accuracy or other causes.
  - The indicated value is the magnetic attraction force generated on one secondary side.

## 5. LINEAR SERVO MOTOR

### 5.5.4 Thrust characteristics

The following shows thrust characteristic for when the power supply input of the servo amplifier is 3-phase 200 V AC, 1-phase 200 V AC, and 1-phase 100 V AC. The 1-phase 200 V AC power input is applicable to LM-K2P1A-01M-2SS1, LM-K2P1C-03M-2SS1, and LM-K2P2A-02M-1SS1. For the 1-phase 200 V AC power supply, the continuous line indicates the thrust characteristic. The 1-phase power supply input is applicable to LM-K2P1A-01M-2SS1.

The continuous/max. thrust and max. speed of the linear servo motor are in the case of the rated power voltage and frequency of the combined servo amplifier.

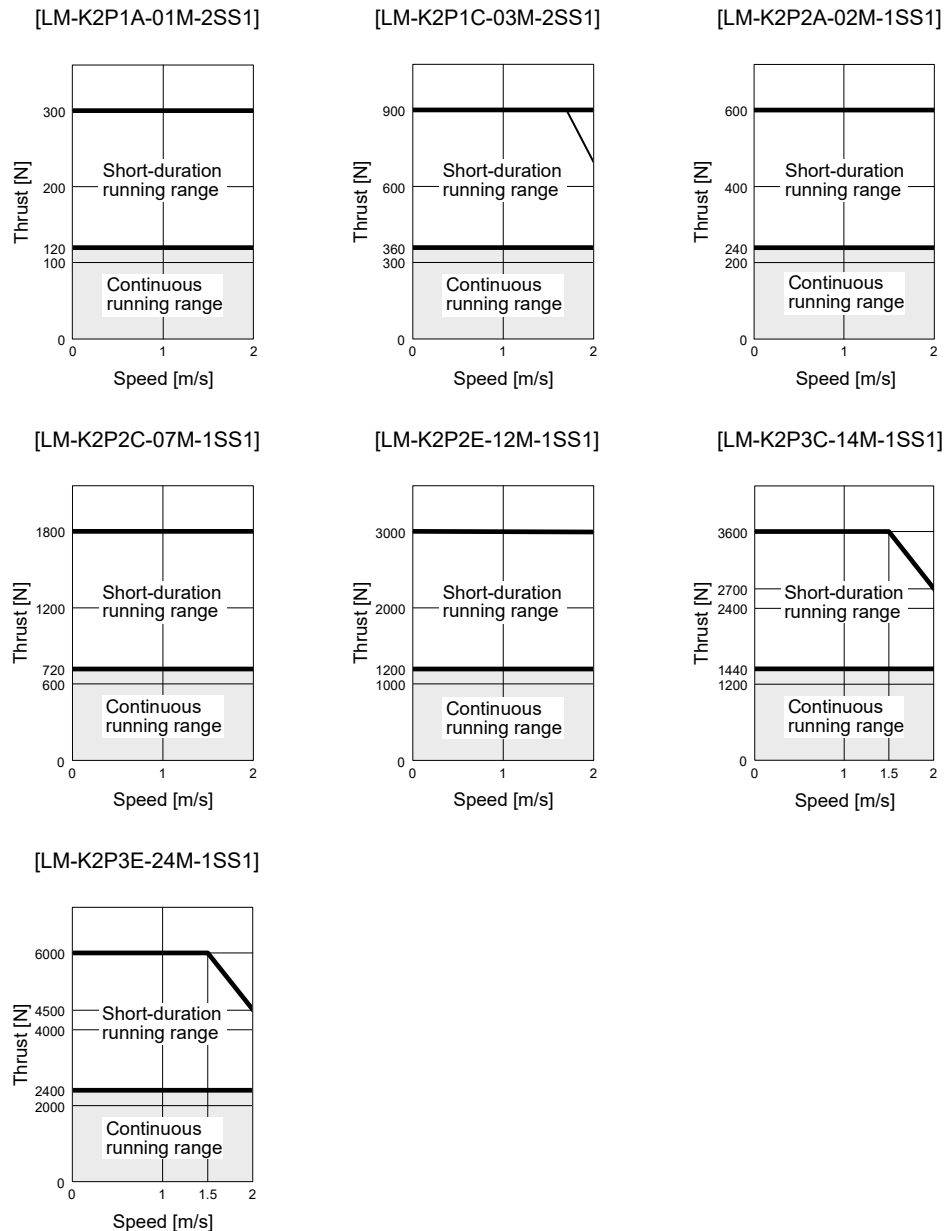

## 5. LINEAR SERVO MOTOR

### 5.5.5 Installation

#### (1) Mounting dimensions

Mount the primary side and secondary side so that the variable dimensions A, C, and F are as defined in the following table. Refer to the outline drawing for details of dimensions.

[Unit: mm]

Linear servo motor	Variable dimensions					
	A	B	C	D	E	F
LM-K2P1A-01M-2SS1	115 <sup>+0.1</sup> <sub>0</sub>	(17.4)	55 ± 0.1	(46)	(1)	38.5 ± 0.1
LM-K2P1C-03M-2SS1						
LM-K2P2A-02M-1SS1	115 <sup>+0.1</sup> <sub>0</sub>	(17.4)	76.5 ± 0.1	(61)	(2)	38.5 ± 0.1
LM-K2P2C-07M-1SS1						
LM-K2P2E-12M-1SS1						
LM-K2P3C-14M-1SS1	139 <sup>+0.1</sup> <sub>0</sub>	(29.4)	116.5 ± 0.1	(101)	(2)	50.5 ± 0.1
LM-K2P3E-24M-1SS1						

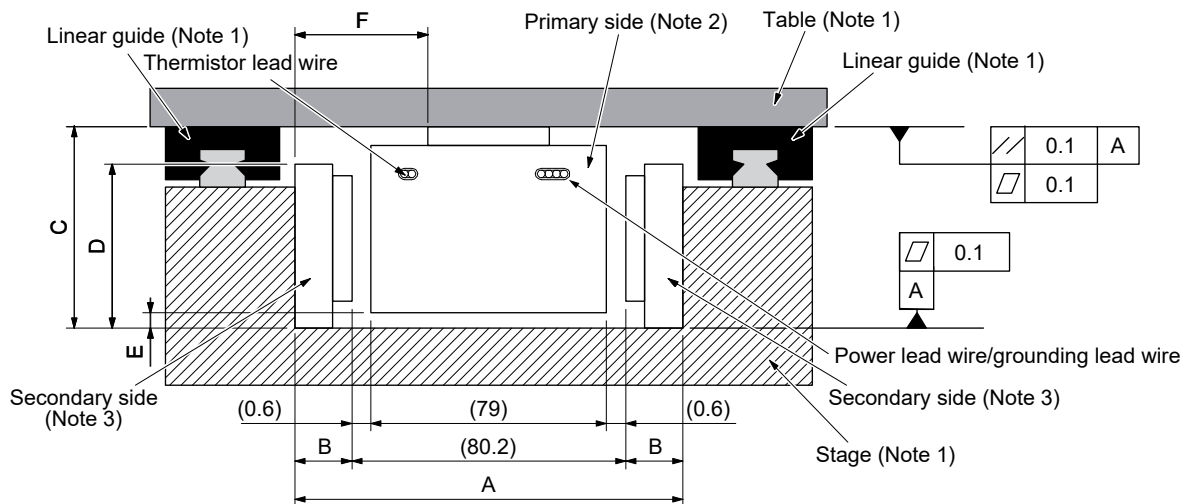

- Note 1. This should be prepared by the customer. Contact each manufacturer for the mounting method.  
 Note 2. Position the primary side using the table flange rabbet.  
 Note 3. One pair of secondary side consist of two secondary sides which are in opposite position. For the opposite side, mount the corresponding secondary side.

#### (2) Installation procedure

**WARNING** ● The permanent magnet on the secondary side makes the magnetic bodies generate attraction force. Be careful not to get your hand stuck.

**CAUTION** ● When mounting the secondary side, use nonmagnetic tools.  
 ● When the additional secondary side is mounted after one has been already set, slide the additional secondary side to mount it in its specified position after setting it away from the already mounted one as shown in this section.  
 ● Keep the cumulative pitch error of the mounting screw holes within ±0.1 mm. When two or more secondary sides are mounted, clearance may be left between the secondary sides depending on the mounting method and the number of secondary sides.  
 ● After installation, confirm that the primary side does not touch the secondary side.

## 5. LINEAR SERVO MOTOR

### Step 1. Installation of secondary side to be a mounting standard

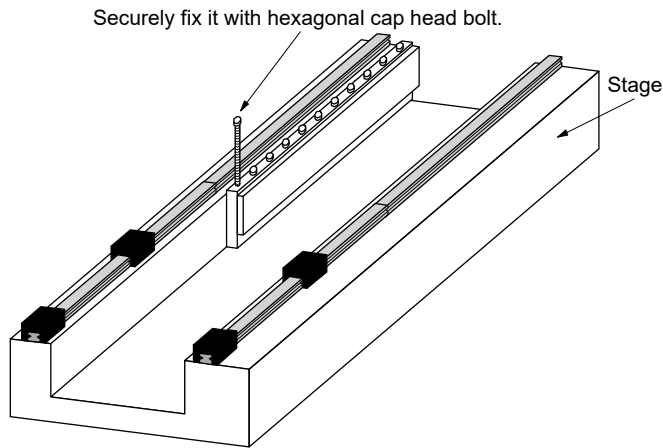

- 1) Set the secondary side which is installed as the first one on the stage.
- 2) Press the side face of the secondary side to the stage, and securely fix it with the hexagonal cap head bolt.

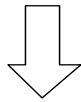

Tool for fitting the end-surface position, etc. (Note)

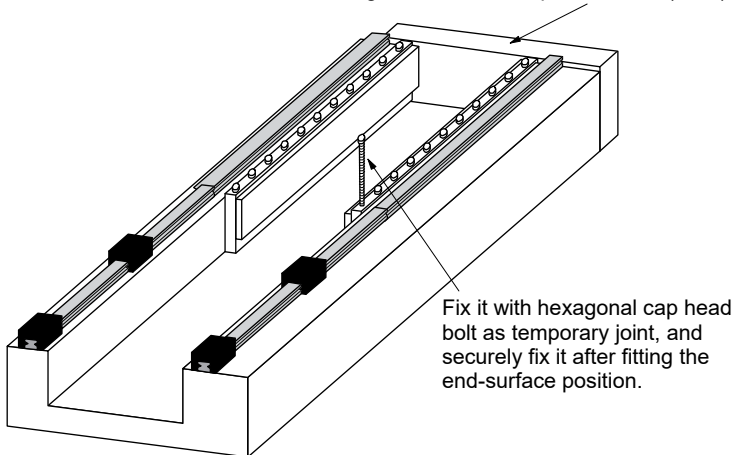

- 3) In the opposite position of the secondary side that is installed in 1) and 2), press the side face of the secondary side which is installed as the second one, and fix it with the hexagonal cap head bolt as temporary joint.
- 4) Using a tool for fitting end-surface position, fit the end-surface of the secondary side which is installed in 1) and 2) and that of temporarily fixed one in 3), and securely fix the two secondary sides with hexagonal cap head bolt.

Note. This should be prepared by the customer.

## 5. LINEAR SERVO MOTOR

---

### Step 2. Installation of the primary side

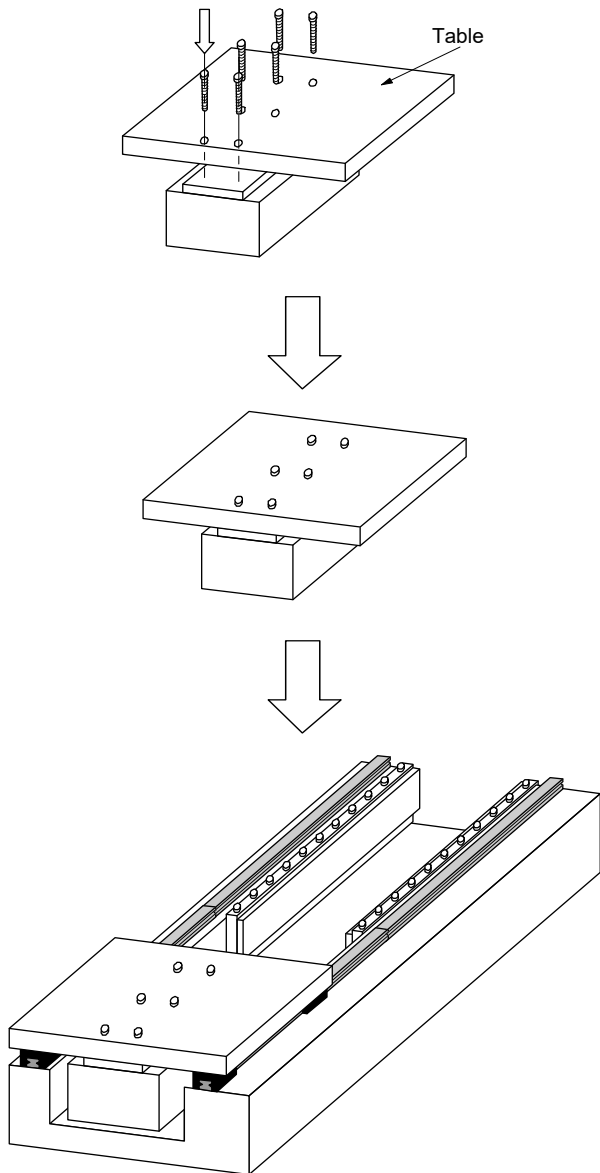

1) Install the table to the primary side with hexagonal cap head bolt.

2) Mount the primary side in the position free from the secondary side.

## 5. LINEAR SERVO MOTOR

### Step 3. Installation of multiple secondary sides

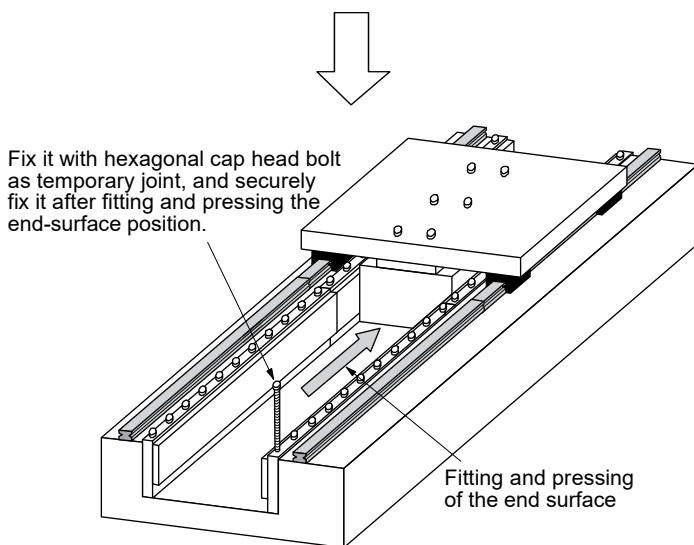
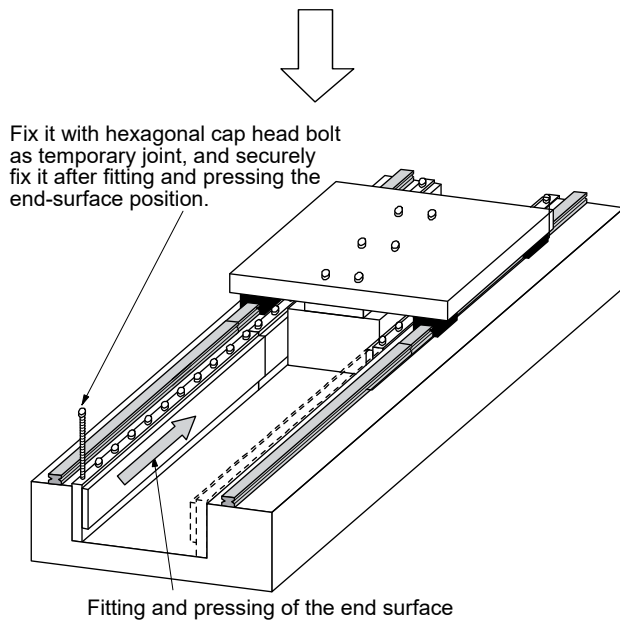
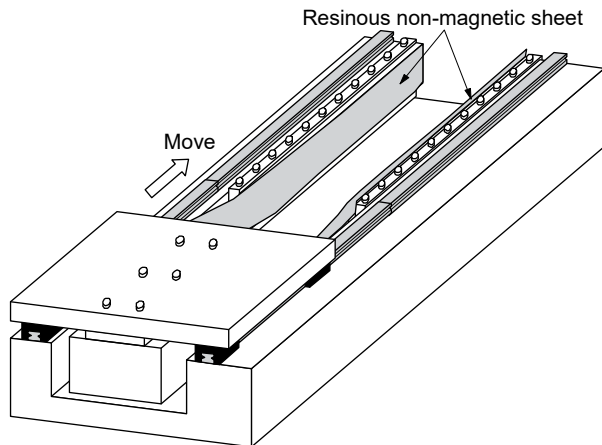

- 1) Set the resinous non-magnetic sheet of approx. 0.3 mm thickness in the both gap parts between the primary and secondary side, and move the primary side toward the secondary side which is installed in Step 1. Remove the resinous non-magnetic sheet after moving the primary side toward the secondary side. When removing, be careful not to scratch the primary and secondary sides.
- 2) Select a secondary side which is installed as the first one from the remaining pairs of secondary sides, and set it on the stage.
- 3) Press the side surface of the secondary side to the stage, and fix it with the hexagonal cap head bolt as temporary joint.
- 4) After fitting and pressing the secondary-side end surface to that of the secondary side which is installed in Step 1, securely fix with hexagonal cap head bolt which was temporarily fixed.
- 5) Install the secondary side in the opposite direction as well with the same steps of 2), 3), and 4).

# 5. LINEAR SERVO MOTOR

## 5.5.6 Dimensions

### (1) Primary side (coil)

#### (a) LM-K2P1A-01M-2SS1

[Unit: mm]

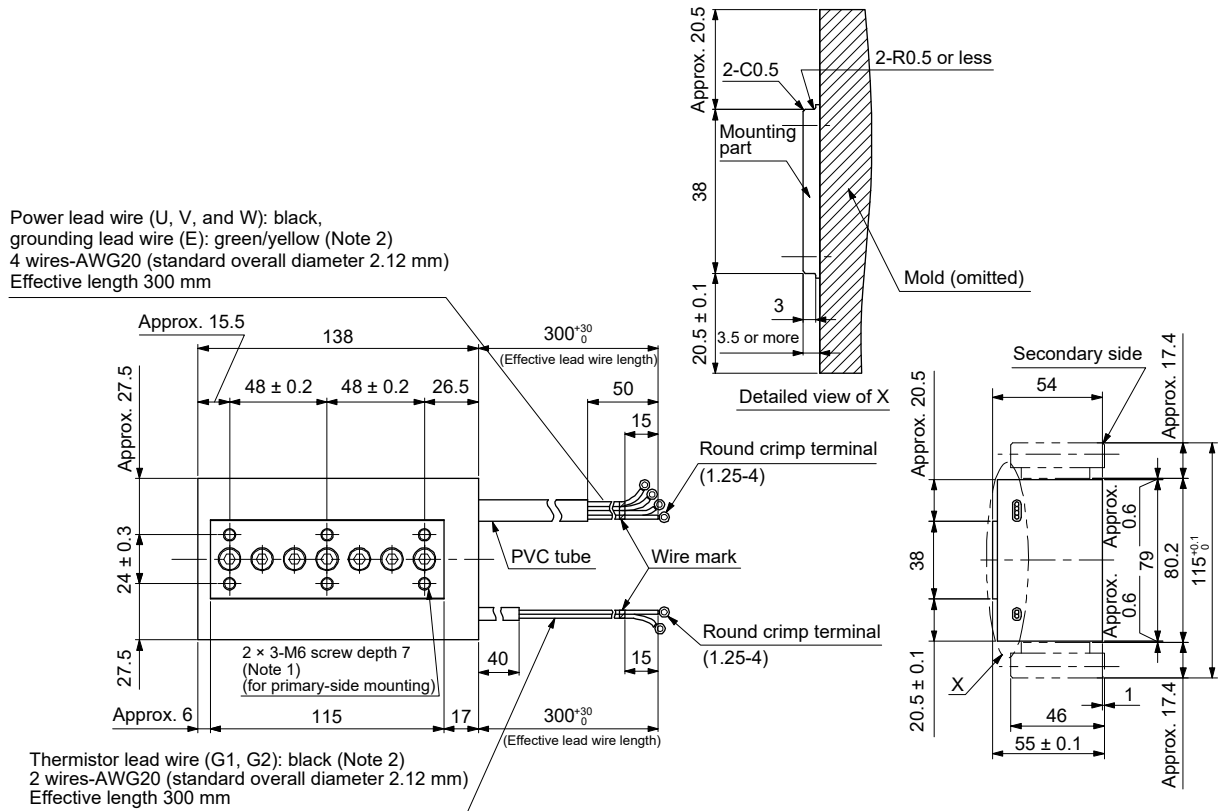

- Note 1. For mounting, use the hexagonal cap head bolt whose material is SCM435 and the lower yield point is 900 N/mm<sup>2</sup> or equivalent.
2. This lead wire is for fixed wiring. Securely fix it to the structure. Minimum bending radius of the lead wire is recommended to be six times or more (reference value) the standard overall diameter of the lead wire. Select the cable used for the moving part considering the speed of linear servo motor and the flexing radius.

# 5. LINEAR SERVO MOTOR

(b) LM-K2P1C-03M-2SS1

[Unit: mm]

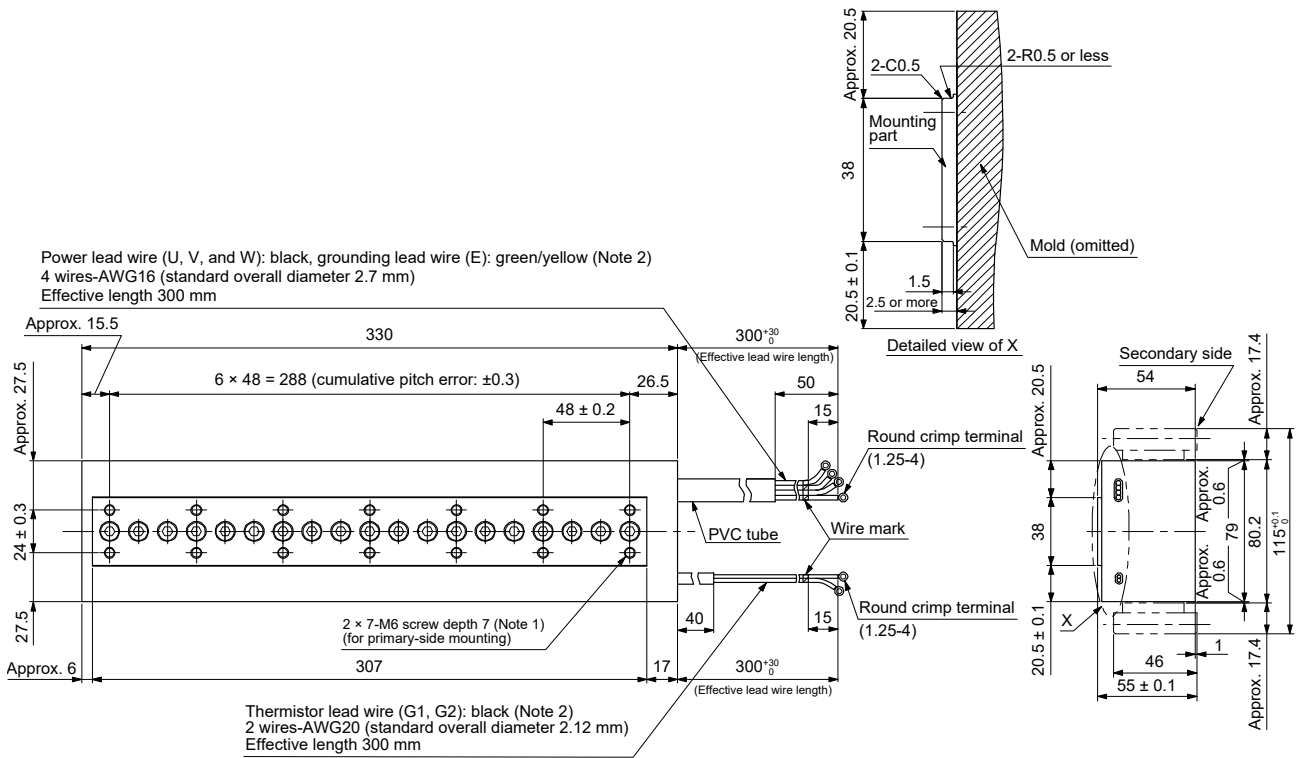

- Note 1. For mounting, use the hexagonal cap head bolt whose material is SCM435 and the lower yield point is 900 N/mm<sup>2</sup> or equivalent.
2. This lead wire is for fixed wiring. Securely fix it to the structure. Minimum bending radius of the lead wire is recommended to be six times or more (reference value) the standard overall diameter of the lead wire. Select the cable used for the moving part considering the speed of linear servo motor and the flexing radius.

# 5. LINEAR SERVO MOTOR

(c) LM-K2P2A-02M-1SS1

[Unit: mm]

Power lead wire (U, V, and W): black,  
grounding lead wire (E): green/yellow (Note 2)  
4 wires-AWG16 (standard overall diameter 2.7 mm)  
Effective length 300 mm

Thermistor lead wire (G1, G2): black (Note 2)  
2 wires-AWG20 (standard overall diameter 2.12 mm)  
Effective length 300 mm

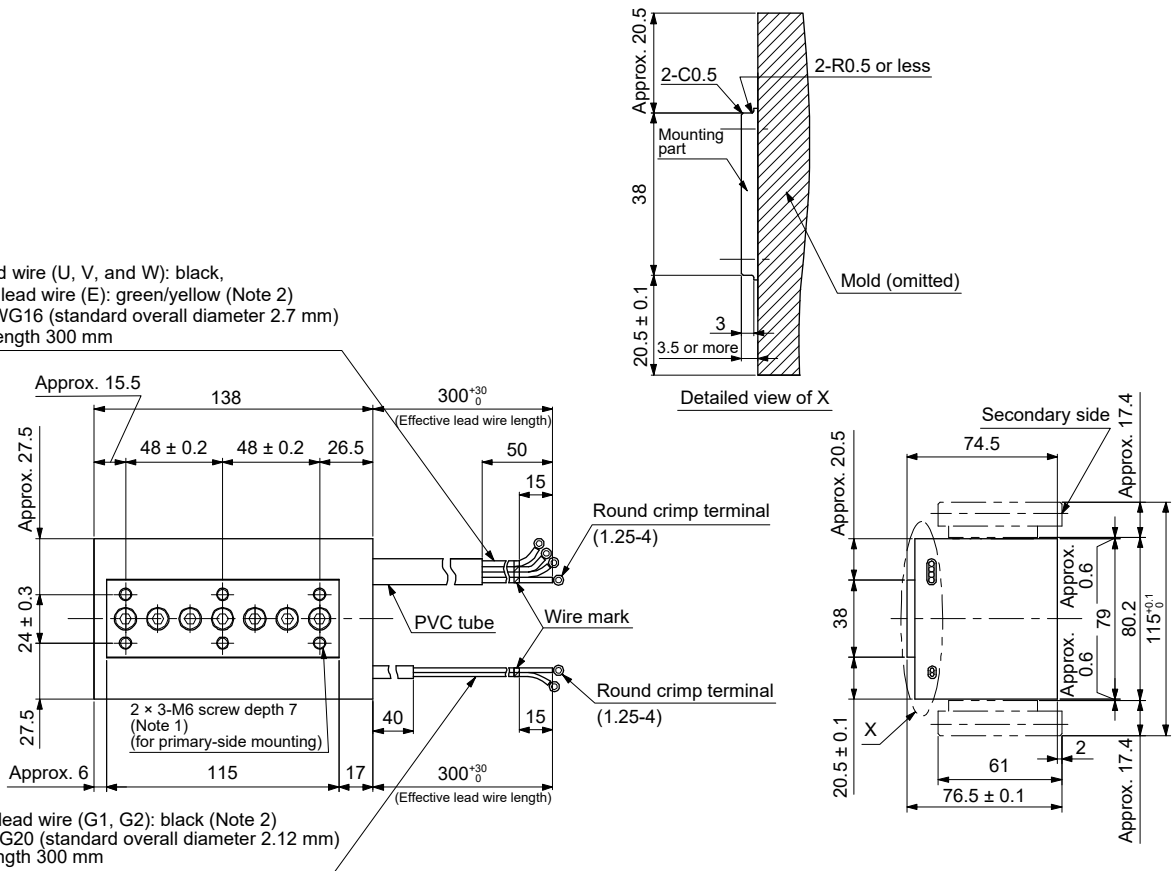

- Note 1. For mounting, use the hexagonal cap head bolt whose material is SCM435 and the lower yield point is 900 N/mm<sup>2</sup> or equivalent.
- Note 2. This lead wire is for fixed wiring. Securely fix it to the structure. Minimum bending radius of the lead wire is recommended to be six times or more (reference value) the standard overall diameter of the lead wire. Select the cable used for the moving part considering the speed of linear servo motor and the flexing radius.

# 5. LINEAR SERVO MOTOR

(d) LM-K2P2C-07M-1SS1

[Unit: mm]

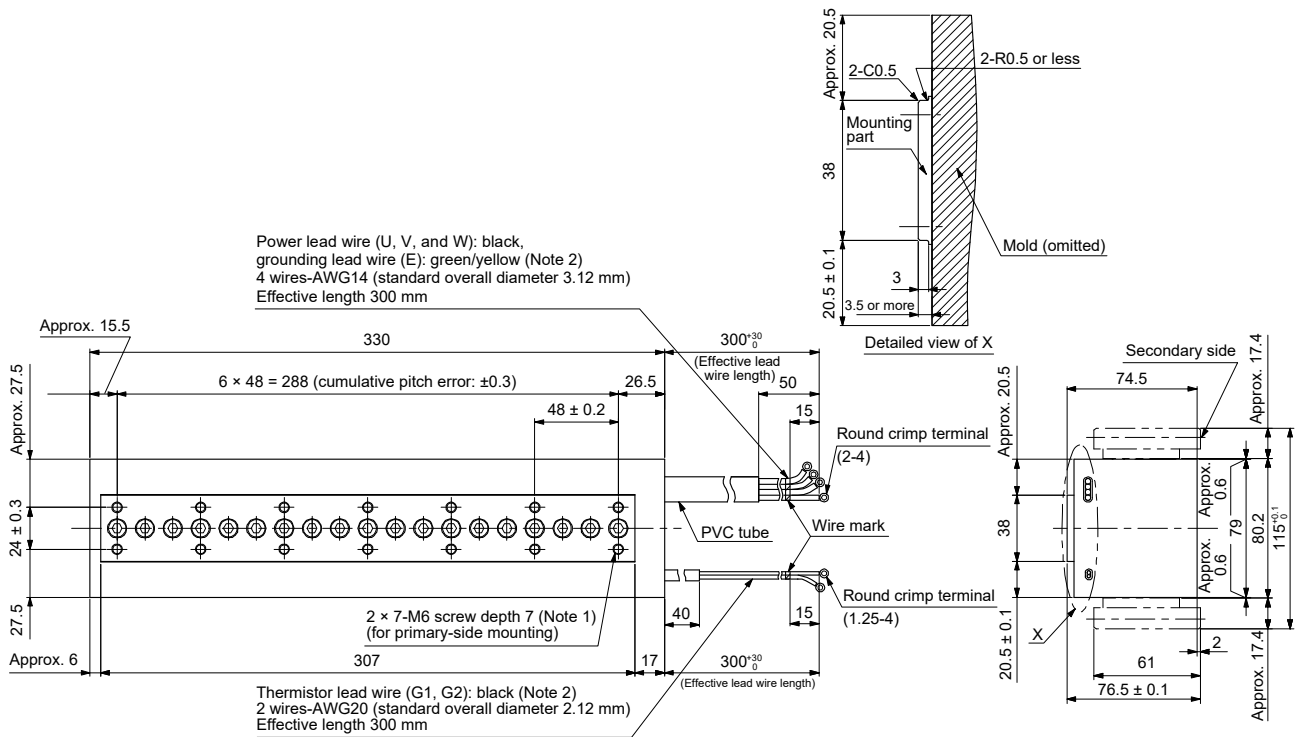

- Note 1. For mounting, use the hexagonal cap head bolt whose material is SCM435 and the lower yield point is 900 N/mm<sup>2</sup> or equivalent.
- Note 2. This lead wire is for fixed wiring. Securely fix it to the structure. Minimum bending radius of the lead wire is recommended to be six times or more (reference value) the standard overall diameter of the lead wire. Select the cable used for the moving part considering the speed of linear servo motor and the flexing radius.

# 5. LINEAR SERVO MOTOR

(e) LM-K2P2E-12M-1SS1

[Unit: mm]

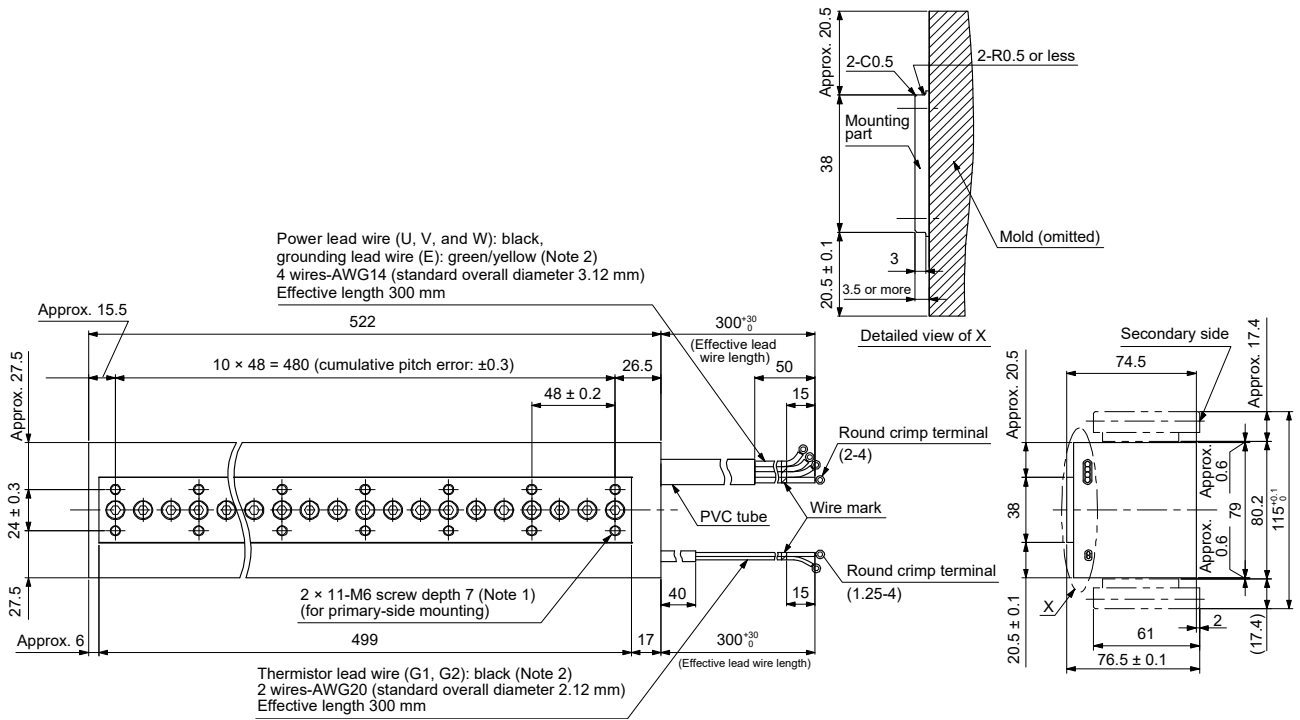

- Note 1. For mounting, use the hexagonal cap head bolt whose material is SCM435 and the lower yield point is 900 N/mm<sup>2</sup> or equivalent.
2. This lead wire is for fixed wiring. Securely fix it to the structure. Minimum bending radius of the lead wire is recommended to be six times or more (reference value) the standard overall diameter of the lead wire. Select the cable used for the moving part considering the speed of linear servo motor and the flexing radius.



# 5. LINEAR SERVO MOTOR

(g) LM-K2P3E-24M-1SS1

[Unit: mm]

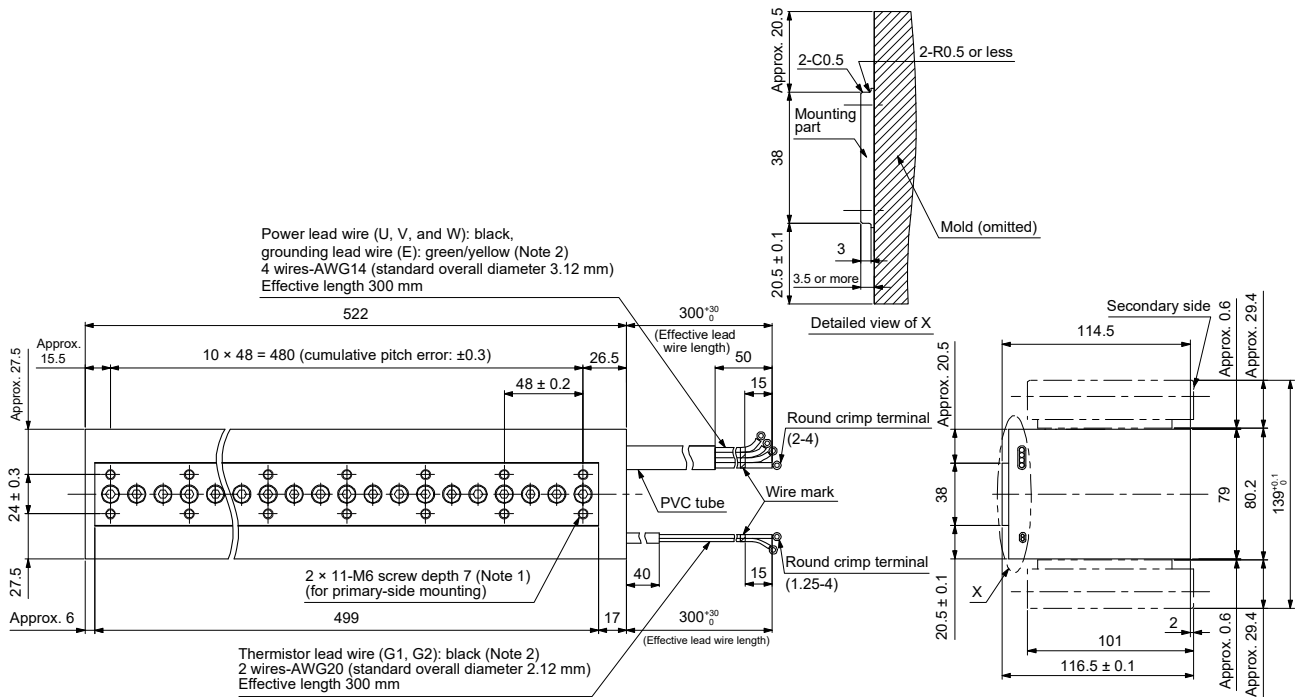

- Note 1. For mounting, use the hexagonal cap head bolt whose material is SCM435 and the lower yield point is 900 N/mm<sup>2</sup> or equivalent.
2. This lead wire is for fixed wiring. Securely fix it to the structure. Minimum bending radius of the lead wire is recommended to be six times or more (reference value) the standard overall diameter of the lead wire. Select the cable used for the moving part considering the speed of linear servo motor and the flexing radius.

# 5. LINEAR SERVO MOTOR

## (2) Secondary side (magnet) (a) LM-K2S10-\_2SS1

[Unit: mm]

Model	Variable dimensions		
	L	M	B
LM-K2S10-288-2SS1	288	5 × 48 = 240	6
LM-K2S10-384-2SS1	384	7 × 48 = 336	8
LM-K2S10-480-2SS1	480	9 × 48 = 432	10
LM-K2S10-768-2SS1	768	15 × 48 = 720	16

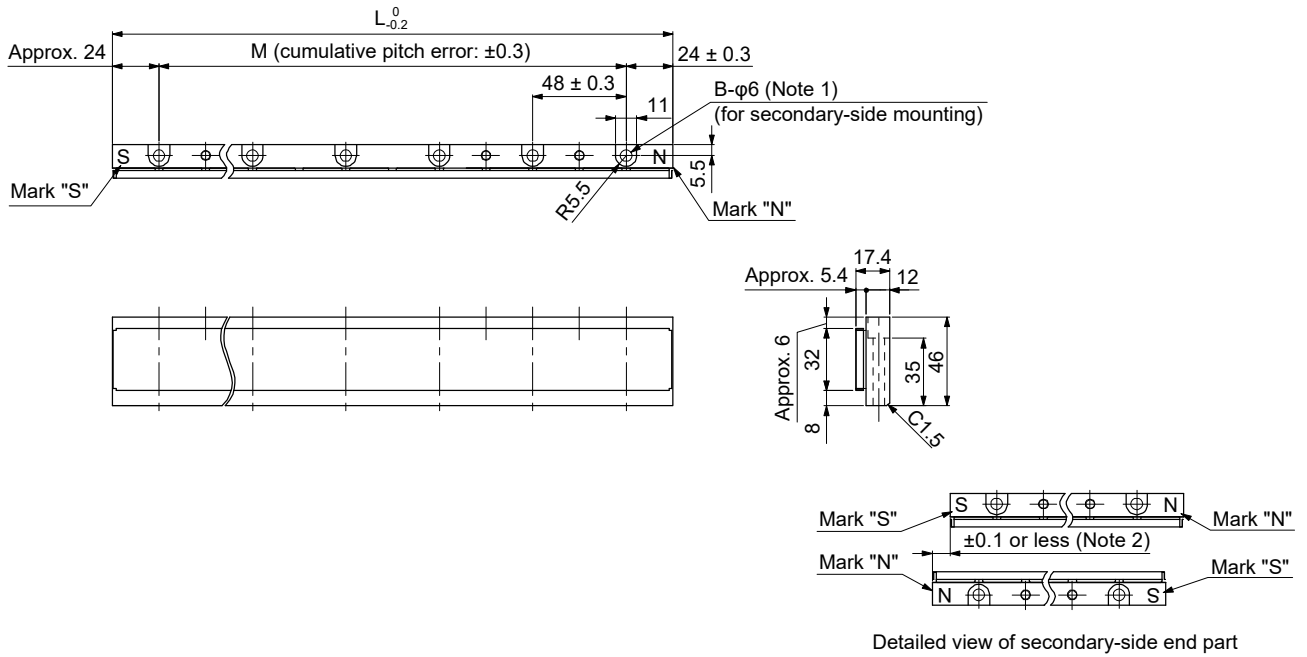

- Note 1. For mounting, use the hexagonal cap head bolt whose material is SCM435 and the lower yield point is 900 N/mm<sup>2</sup> or equivalent.
- Note 2. Longitudinal deviation of the secondary side must be within  $\pm 0.1$  mm. (Refer to the detailed view of secondary-side edge.)



# 5. LINEAR SERVO MOTOR

(c) LM-K2S30-\_-1SS1

[Unit: mm]

Model	Variable dimensions		
	L	M	B
LM-K2S30-288-1SS1	288	8 × 32 = 256	9
LM-K2S30-384-1SS1	384	11 × 32 = 352	12
LM-K2S30-480-1SS1	480	14 × 32 = 448	15
LM-K2S30-768-1SS1	768	23 × 32 = 736	24

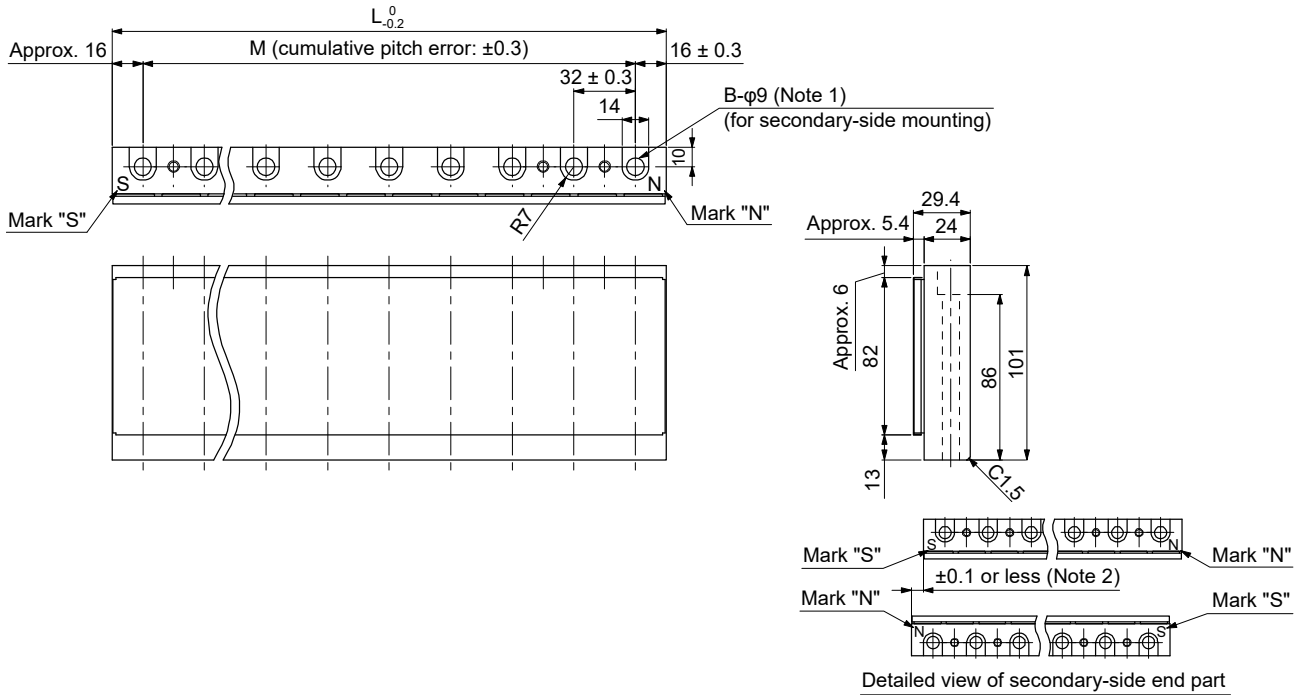

- Note 1. For mounting, use the hexagonal cap head bolt whose material is SCM435 and the lower yield point is 900 N/mm<sup>2</sup> or equivalent.
- Note 2. Longitudinal deviation of the secondary side must be within  $\pm 0.1$  mm. (Refer to the detailed view of secondary-side edge.)



# APPENDIX

## APPENDIX

### App. 1 Capacity selection of linear servo motor

#### App. 1.1 Selection of linear servo motor

Select a linear servo motor according to the purpose of the machine for which it is installed. When the machine on which a linear servo motor is installed is not compatible with the motor, the performance of the linear servo motor cannot be fully got out of, and it is difficult to perform the gain adjustment. Select a linear servo motor correctly with the full understanding of the characteristics of linear servo motor with reference to this section.

(1) Maximum feed speed

The maximum speed for LM-H3 series is 3.0 m/s. The maximum speed for LM-F, LM-K2, and LM-U2 series is 2.0 m/s. Note, however, that 2.0 m/s cannot be reached depending on the selected linear encoder.

(2) Selection of the primary side (coil) (theoretical value)

Aside from the continuous thrust, the linear servo motor has the output area (maximum thrust) that can be used only for a short time such as acceleration/deceleration, and that can provide about triple thrust of the rated.

Calculate the continuous effective load thrust and the required maximum thrust from all data of the machine and the operation pattern, and select a linear servo motor applicable to those results. The following indicates the selection example for the operation pattern of linear acceleration/deceleration.

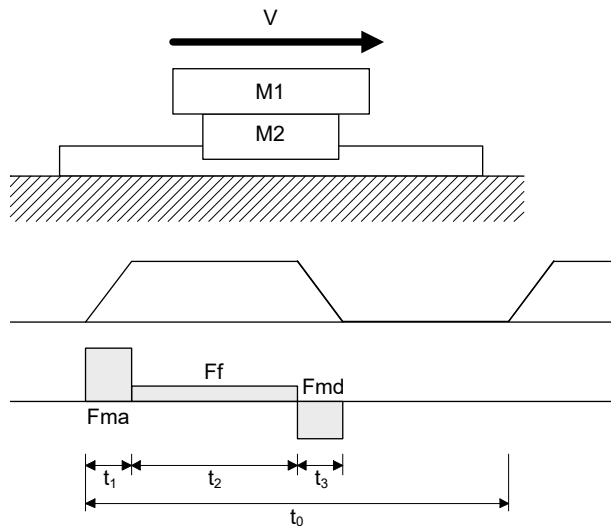

- V: Feed speed [m/s]
- M1: Load mass [kg]
- M2: Weight on linear servo motor primary side [kg]
- Fma: Acceleration time thrust [N]
- Ff: Resistive power [N]  
(including friction, imbalance, and cableveyor®)
- Fmd: Deceleration time thrust [N]
- t1: Acceleration time [s]
- t2: Constant velocity time [s]
- t3: Deceleration time [s]
- t0: Operation cycle [s]
- a: Acceleration speed [m/s<sup>2</sup>]
- d: Deceleration speed [m/s<sup>2</sup>]
- η: Mechanical efficiency
- μ: Friction coefficient

1) Temporary selection

From the linear servo motor series that is suitable for your application or machine, select a linear servo motor with the mass ratio of load to primary side which is equal to or less than the recommended load to motor mass ratio. (refer to the specification list of each linear servo motor).

$$\text{Recommended load to motor mass ratio} \geq M1/M2$$

# APPENDIX

2) Calculation of resistive power

$$M = M1 + M2 \text{ [kg]}$$

$$F_f = \mu \cdot (M \cdot 9.8 + \text{Magnetic attraction force}) \text{ [N]} \text{ (when considering only friction)}$$

3) Calculation of acceleration time thrust and deceleration time thrust

$$F_{ma} = M \cdot a + F_f \text{ [N]}$$

$$F_{md} = -M \cdot d + F_f \text{ [N]}$$

4) Calculation of continuous effective load thrust

$$F_{rms} = \sqrt{(F_{ma}^2 \cdot t_1 + F_f^2 \cdot t_2 + F_{md}^2 \cdot t_3)/t_0} \text{ [N]}$$

5) Determination of linear servo motor selected

$$F_{rms}/\eta \leq \text{Continuous thrust [N] of the temporarily selected motor}$$

$$F_{ma}/\eta \leq \text{Maximum thrust [N] of the temporarily selected motor}$$

If the above conditions are not satisfied, select one rank larger capacity linear servo motor and recalculate.

(3) Number selection of secondary side (magnet) blocks

Select the number of secondary side blocks by the combination with which the following equation is satisfied.

$$(\text{Total length of secondary sides which are set out}) \geq (\text{Maximum feed distance}) + (\text{Length of primary side})$$

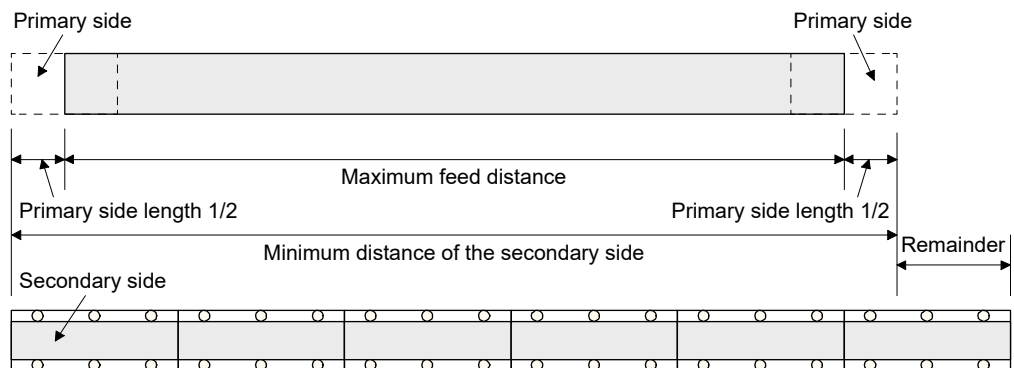

# APPENDIX

## (4) Selection of the regenerative option

The following table shows the energy charged into the capacitor of the servo amplifier and the inverse efficiency of the linear servo motor.

### 1) 200 V class and 400 V class

Servo amplifier	Inverse efficiency [%]	C charge [J]	Regenerative power [W]									
			Built-in regenerative resistor	MR-RB032 [40 Ω]	MR-RB12 [40 Ω]	MR-RB30 [13 Ω]	MR-RB3N [9 Ω]	MR-RB31 [6.7 Ω]	MR-RB32 [40 Ω]	(Note 1) MR-RB50 [13 Ω]	(Note 1) MR-RB5N [9 Ω]	(Note 1) MR-RB51 [6.7 Ω]
MR-J4-20A(-RJ) MR-J4-20B(-RJ) MR-J4-20GF(-RJ)	75	9	10	30	100							
MR-J4-40A(-RJ) MR-J4-40B(-RJ) MR-J4-40GF(-RJ)	85	11	10	30	100							
MR-J4-60A(-RJ) MR-J4-60B(-RJ) MR-J4-60GF(-RJ)	85	11	10	30	100							
MR-J4-70A(-RJ) MR-J4-70B(-RJ) MR-J4-70GF(-RJ)	85	18	20	30	100				300			
MR-J4-200A(-RJ) MR-J4-200B(-RJ) MR-J4-200GF(-RJ)	85	36	100			300				500		
MR-J4-350A(-RJ) MR-J4-350B(-RJ) MR-J4-350GF(-RJ)	85	40	100				300				500	
MR-J4-500A(-RJ) MR-J4-500B(-RJ) MR-J4-500GF(-RJ)	90	45	130					300				500
MR-J4-700A(-RJ) MR-J4-700B(-RJ) MR-J4-700GF(-RJ)	90	70	170					300				500

Servo amplifier	Inverse efficiency [%]	C charge [J]	(Note 2) Regenerative power [W]		
			External regenerative resistor (Accessory)	MR-RB5R [3.2 Ω]	MR-RB9F [3 Ω]
MR-J4-11KA(-RJ) MR-J4-11KB(-RJ) MR-J4-11KGF(-RJ)	90	120	500 (800)	500 (800)	
MR-J4-15KA(-RJ) MR-J4-15KB(-RJ) MR-J4-15KGF(-RJ)	90	170	850 (1300)		850 (1300)
MR-J4-22KA4(-RJ) MR-J4-22KB4(-RJ) MR-J4-22KGF4 (-RJ)	90	250	850 (1300)		850 (1300)

Note 1. Always install a cooling fan.

2. Values in parentheses are for using a cooling fan and setting [Pr. PA02] properly.

# APPENDIX

---

## 2) 100 V class

Servo amplifier	Inverse efficiency [%]	C charge [J]	Regenerative power [W]		
			Built-in regenerative resistor	MR-RB032 [40 Ω]	MR-RB12 [40 Ω]
MR-J4-20A1(-RJ) MR-J4-20B1(-RJ)	75	4	10	30	100
MR-J4-40A1(-RJ) MR-J4-40B1(-RJ)	85	10	10	30	100

The energy used by the regenerative resistor can be calculated by subtracting losses from the deceleration time thrust which was calculated when temporarily selecting the linear servo motor.

Regenerative energy P (W) =  $\{-Fmd \cdot (t_3 \cdot \text{Speed}/2) \cdot (\text{Inverse efficiency}/100) - \text{Capacitor charging}\}/t_0$

Select the regenerative option as necessary so that the used energy becomes less than the regenerative power.

# APPENDIX

---

## App. 1.2 Selection example including regeneration

Mechanical Load mass: 20 kg	Acceleration time: 0.125 s
conditions Feed speed: 1.8 m/s	Deceleration time: 0.125 s
Feed distance: 1600 mm	Efficiency of mechanical system $\eta$ : 1.0
Feed time: 1 s	Friction coefficient $\mu$ : 0.020
	1 cycle time: 2 s

### (1) Temporary selection and calculation of resistive power

When the operation pattern is decided by setting the acceleration time as  $t_1 = 0.125$  s, the deceleration time as  $t_3 = 0.125$  s, the constant speed time will be  $t_2 = 0.75$  s.

$$\text{Acceleration: } a = 1.8 \text{ [m/s]} / 0.125 \text{ [s]} = 14.4 \text{ [m/s}^2\text{]}$$

$$\text{Deceleration: } d = 1.8 \text{ [m/s]} / 0.125 \text{ [s]} = 14.4 \text{ [m/s}^2\text{]}$$

Select temporarily the linear servo motor whose load to motor mass ratio is 35 times or less (LM-H3P2A-07P-BSS0, LM-H3P3A-12P-CSS0, and LM-H3P3B-24P-CSS0), and calculate to see whether it satisfies each machine conditions (acceleration time thrust, deceleration time thrust, and continuous effective load thrust).

The following shows the calculation example of temporarily selected LM-H3P3B-24P-CSS0 which satisfies the machine conditions.

Mass: 2.3 kg
Magnetic attraction force: 2200 N
Continuous thrust: 240 N
Maximum thrust: 600 N

### (2) Calculation of thrust during acceleration and deceleration (when considering only friction)

$$M = \text{Load mass} + \text{Primary side mass}$$

$$F_f = \mu \cdot (M \cdot 9.8 + \text{Magnetic attraction force}) = 0.020 \times \{(20 + 2.3) \times 9.8 + 2200\} = 48.4 \text{ [N]}$$

$$F_{ma} = M \cdot a + F_f = (20 + 2.3) \times 14.4 \text{ m/s}^2 + 48.4 = 369.5 \text{ [N]}$$

$$F_{md} = -M \cdot d + F_f = -(20 + 2.3) \times 14.4 \text{ m/s}^2 + 48.4 = -272.7 \text{ [N]}$$

## APPENDIX

---

### (3) Calculation of continuous effective load thrust

$$\begin{aligned} F_{rms} &= \sqrt{(F_{ma}^2 \cdot t_1 + F_f^2 \cdot t_2 + F_{md}^2 \cdot t_3)/t_0} \\ &= \sqrt{(369.5^2 \times 0.125 + 48.4^2 \times 0.75 + (-272.7)^2 \times 0.125)/2} = 118.6 \text{ [N]} \end{aligned}$$

$$F_{rms}/\eta = 118.6/1.0 = 118.6 \text{ [N]}$$

As a result of this, the continuous thrust is less than 240 N, and therefore the linear servo motor is available.

$$F_{ma}/\eta = 369.5/1.0 = 369.5 \text{ [N]}$$

As a result of this, the maximum thrust is less than 600 N, and therefore the linear servo motor is available.

### (4) Number of secondary sides (magnet)

$$(\text{Maximum feed distance}) + (\text{Length of primary side}) = 1600 + 224 = 1824 \text{ [mm]}$$

As a result of this, the total length of the secondary sides that are set out should be 1824 mm or more, and one of the followings can be selected.

- (a) Four LM-H3S30-480-CSS0 magnets (total of 1920 mm)
- (b) Five LM-H3S30-384-CSS0 magnets (total of 1920 mm)
- (c) Seven LM-H3S30-288-CSS0 magnets (total of 2016 mm)
- (d) Two LM-H3S30-768-CSS0 and one LM-H3S30-288-CSS0 magnets (Total of 1824 mm)

### (5) Regenerative energy calculation

$$\begin{aligned} P \text{ [W]} &= \{-F_{md} \cdot (t_3 \cdot \text{Speed}/2) \cdot (\text{Inverse efficiency}/100) - \text{Capacitor charging}\}/t_0 \\ &= \{272.7 \times (0.125 \times 1.8/2) \times (80/100) - 18\}/2 = 3.3 \text{ [W]} \end{aligned}$$

(MR-J4-70B servo amplifier is used.)

As the regenerative energy does not exceed the regenerative power (20 W), the regenerative option is not required.

Selection results    Linear servo amplifier: MR-J4-70B  
                          Linear servo motor  
                          Primary side: LM-H3P3B-24P-CSS0  
                          Secondary side: LM-H3S30-480-CSS0 (four magnets)  
                          Regenerative option: Not required

# APPENDIX

## App. 2 Wiring option

**POINT**

●Wiring option for MR-J4 1-axis servo amplifier is not available.

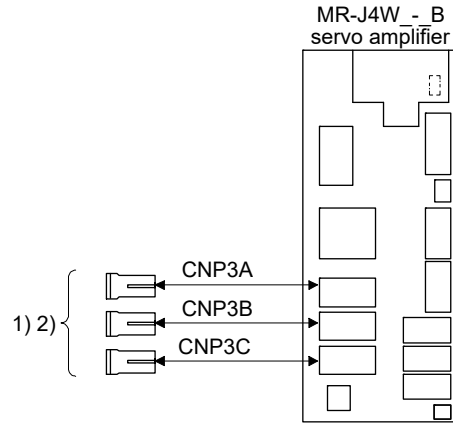

No.	Product	Model	Description	Application
1)	Connector set	MR-J3WCNP3-D2L	 For CNP3A/CNP3B/CNP3C Receptacle housing: F35FDC-04V-K Receptacle contact: BF3F-71GF-P2.0 (JST)	Quantity: 1 For thick wire
2)	Connector set	MR-J3WCNP3-D2L-20P	Applicable wire example Wire size: 1.25 mm <sup>2</sup> (AWG 16) to 2.0 mm <sup>2</sup> (AWG 14) Insulator OD: 2.4 mm to 3.4 mm The crimping tool (YRF-1070) is required.	Quantity: 20 For thick wire

## App. 3 Manufacturer list

Names given in the table are as of March 2020.

For information, such as the delivery time, price, and specifications of the recommended products, contact each manufacturer.

Manufacturer	Contact
NGK	NGK Insulators, Ltd.
DDK	DDK Ltd.
JST	J.S.T. Mfg. Co., Ltd.

REVISIONS

\*The manual number is given on the bottom left of the back cover.

Revision Date	*Manual Number	Revision	
Mar. 2012	SH(NA)030110ENG-A	First edition	
May 2012	SH(NA)030110ENG-B	Section 1.3 Section 4.2 Section 5.2.4	The sentences of WARNING is changed. Note is added. The graph is changed to 3-phase 200 V AC and 1-phase 200 V AC.
Feb. 2013	SH(NA)030110ENG-C	Chapter 4 Section 4.2 Section 4.2.2 Section 4.3 Section 4.4 Section 5.2.3 Section 5.2.6 (1) Section 5.3.3 Section 5.3.6 (1) Section 5.4.1 Section 5.4.2 Section 5.4.3 Section 5.4.4 Section 5.4.5 (1) Section 5.4.6 (1) Section 5.4.7 (1) Section 5.4.7 (2) Section 5.5.2 Section 5.5.3 App. 1.1 (4)	POINT is added. POINT is added. The diagram is changed. The table is changed. The sentences are added to POINT. The table is changed. Note is changed. The table is changed. CAUTION is changed. Model is added. The table is changed. The table is changed. The sentences are changed, graph is added. Note is changed. CAUTION is changed. (f) to (h) is added. (c) is added. The table is changed. The table is changed. The table is changed.
Sep. 2014	SH(NA)030110ENG-D	1-phase 100 V AC class servo amplifiers are added. Section 4.4 Section 5.2.2 Section 5.2.3 Section 5.2.4 Section 5.3.2 Section 5.3.3 Section 5.3.4 Section 5.4.3 Section 5.5.2 Section 5.5.3 Section 5.5.4 App. 1 (4)	Model names are added. Model names are added. Note is added. 1-phase 100 V AC class is added. Model names are added. Note is added. 1-phase 100 V AC class is added. Note is added. Model names are added. Note is added. 1-phase 100 V AC class is added. 1-phase 100 V AC class is added.
Sep. 2015	SH(NA)030110ENG-E	Thrust characteristic at 1-phase 200 V AC input is added. 2. To prevent fire, note the following 4. Additional instructions Section 1.3 Section 5.2.4 Section 5.3.4 Section 5.4.4 Section 5.5.3 Section 5.5.4 App. 3	Partially added. Partially added. Partially changed. Partially added. Partially added and partially changed. Partially added and partially changed. Partially added. Partially added and partially changed. Partially changed.
Feb. 2016	SH(NA)030110ENG-F	Model names MR-J4-_GF of servo amplifiers are added. Chapter 4 Section 5.1	Model names are added. Rating plates are changed.

Revision Date	*Manual Number	Revision	
Feb. 2016	SH(NA)030110ENG-F	Section 5.2.2 Section 5.2.3 Section 5.3.2 Section 5.3.3 Section 5.4.2 Section 5.4.3 Section 5.5.2 Section 5.5.3 Section 5.5.5 App. 1	Model names are added. Partially added. Model names are added. Partially added. Model names are added. Partially added. Model names are added. Partially added. Partially changed. Model names are added.
Dec. 2016	SH(NA)030110ENG-G	"Available in the future" for MR-J4-GF is deleted. Front cover 4. Additional instructions (1) Transportation and installation Section 1.4 (4) Section 5.1 Section 5.2.3 Section 5.3.3 Section 5.4.3 Section 5.5.3	"Available in the future" is deleted.  The ambient humidity is changed.  The ambient humidity is changed. The rating plates are changed. The ambient humidity is changed. The ambient humidity is changed. The ambient humidity is changed. The ambient humidity is changed.
Jul. 2017	SH(NA)030110ENG-H	Dimensions of LM-U2SB0- and LM-U2SB0- are changed. 3. To prevent injury, note the following 4. Additional instructions Chapter 4 Section 4.4 Section 5.3.1 Section 5.3.2 Section 5.3.3 Section 5.3.6	Partially added.  Partially added. CAUTION is partially added. POINT is added and partially changed. Model names are changed. Model names are changed. Model names are changed. Model names are changed. Dimensions are changed.
Mar. 2020	SH(NA)030110ENG-J	Information on disposal of linear servo motors is changed. 4. Additional instructions (4) Usage HANDLING OF LINEAR SERVO MOTOR 5. Disposal of linear servo motor Section 5.2.2 Section 5.3.2 Section 5.5.2	The sentences are added.   (3) is deleted.  Point is added. Point is added. Point is added.
Nov. 2025	SH(NA)030110ENG-K	The back cover is changed.	

This manual confers no industrial property rights or any rights of any other kind, nor does it confer any patent licenses. Mitsubishi Electric Corporation cannot be held responsible for any problems involving industrial property rights which may occur as a result of using the contents noted in this manual.



MELSERVO is a trademark or registered trademark of Mitsubishi Electric Corporation in Japan and/or other countries.  
Cableveyor is registered trademark of TSUBAKIMOTO CHAIN CO.  
All other product names and company names are trademarks or registered trademarks of their respective companies.

## Warranty

### 1. Warranty period and coverage

We will repair any failure or defect hereinafter referred to as "failure" in our FA equipment hereinafter referred to as the "Product" arisen during warranty period at no charge due to causes for which we are responsible through the distributor from which you purchased the Product or our service provider. However, we will charge the actual cost of dispatching our engineer for an on-site repair work on request by customer in Japan or overseas countries. We are not responsible for any on-site readjustment and/or trial run that may be required after a defective unit are repaired or replaced.

### [Term]

For terms of warranty, please contact your original place of purchase.

### [Limitations]

- (1) You are requested to conduct an initial failure diagnosis by yourself, as a general rule.  
It can also be carried out by us or our service company upon your request and the actual cost will be charged. However, it will not be charged if we are responsible for the cause of the failure.
- (2) This limited warranty applies only when the condition, method, environment, etc. of use are in compliance with the terms and conditions and instructions that are set forth in the instruction manual and user manual for the Product and the caution label affixed to the Product.
- (3) Even during the term of warranty, the repair cost will be charged on you in the following cases;
  - (i) a failure caused by your improper storing or handling, carelessness or negligence, etc., and a failure caused by your hardware or software problem
  - (ii) a failure caused by any alteration, etc. to the Product made on your side without our approval
  - (iii) a failure which may be regarded as avoidable, if your equipment in which the Product is incorporated is equipped with a safety device required by applicable laws and has any function or structure considered to be indispensable according to a common sense in the industry
  - (iv) a failure which may be regarded as avoidable if consumable parts designated in the instruction manual, etc. are duly maintained and replaced
  - (v) any replacement of consumable parts (battery, fan, smoothing capacitor, etc.)
  - (vi) a failure caused by external factors such as inevitable accidents, including without limitation fire and abnormal fluctuation of voltage, and acts of God, including without limitation earthquake, lightning and natural disasters
  - (vii) a failure generated by an unforeseeable cause with a scientific technology that was not available at the time of the shipment of the Product from our company
  - (viii) any other failures which we are not responsible for or which you acknowledge we are not responsible for

### 2. Term of warranty after the stop of production

- (1) We may accept the repair at charge for another seven (7) years after the production of the product is discontinued. The announcement of the stop of production for each model can be seen in our Sales and Service, etc.
- (2) Please note that the Product (including its spare parts) cannot be ordered after its stop of production.

### 3. Service in overseas countries

Our regional FA Center in overseas countries will accept the repair work of the Product. However, the terms and conditions of the repair work may differ depending on each FA Center. Please ask your local FA center for details.

### 4. Exclusion of loss in opportunity and secondary loss from warranty liability

Regardless of the gratis warranty term, Mitsubishi shall not be liable for compensation to:

- (1) Damages caused by any cause found not to be the responsibility of Mitsubishi.
- (2) Loss in opportunity, lost profits incurred to the user by Failures of Mitsubishi products.
- (3) Special damages and secondary damages whether foreseeable or not, compensation for accidents, and compensation for damages to products other than Mitsubishi products.
- (4) Replacement by the user, maintenance of on-site equipment, start-up test run and other tasks.

### 5. Change of Product specifications

Specifications listed in our catalogs, manuals or technical documents may be changed without notice.

### 6. Application and use of the Product

- (1) For the use of our General-Purpose AC Servo, its applications should be those that may not result in a serious damage even if any failure or malfunction occurs in General-Purpose AC Servo, and a backup or fail-safe function should operate on an external system to General-Purpose AC Servo when any failure or malfunction occurs.
- (2) Our General-Purpose AC Servo is designed and manufactured as a general purpose product for use at general industries. Therefore, applications substantially influential to the public interest for such as atomic power plants and other power plants of electric power companies, and also which require a special quality assurance system, including applications for railway companies and government or public offices are not recommended, and we assume no responsibility for any failure caused by these applications when used.  
In addition, applications which may be substantially influential to human lives or properties for such as airlines, medical treatments, railway service, incineration and fuel systems, man-operated material handling equipment, entertainment machines, safety machines, etc. are not recommended, and we assume no responsibility for any failure caused by these applications when used. We will review the acceptability of the abovementioned applications, if you agree not to require a specific quality for a specific application. Please contact us for consultation.
- (3) Mitsubishi Electric shall have no responsibility or liability for any problems involving programmable controller trouble and system trouble caused by DoS attacks, unauthorized access, computer viruses, and other cyberattacks.

SH(NA)-030110ENG-K(2511)MEE

MODEL: LINEAR SERVO MOTOR INSTRUCTION MANUAL

MODEL CODE: 1CW953

## **MITSUBISHI ELECTRIC CORPORATION**

HEAD OFFICE: TOKYO BLDG., 2-7-3, MARUNOUCHI, CHIYODA-KU, TOKYO 100-8310, JAPAN  
NAGOYA WORKS: 1-14, YADA-MINAMI 5-CHOME, HIGASHI-KU, NAGOYA 461-8670, JAPAN

When exported from Japan, this manual does not require application to the  
Ministry of Economy, Trade and Industry for service transaction permission.

Specifications subject to change without notice.

Compliance with the indicated global standards and regulations is current as of the release date of this manual.