

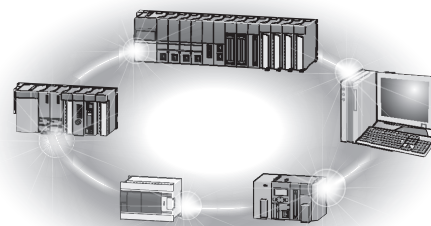

Mitsubishi Programmable Controller

CC-Link Remote I/O Module (With Diagnostic Functions) User's Manual

-AJ65ABTP3-16D
-AJ65ABTP3-16DE



● SAFETY PRECAUTIONS ●

(Read these precautions before using this product.)

Before using this product, please read this manual and the relevant manuals carefully and pay full attention to safety to handle the product correctly.

In this manual, the safety precautions are classified into two levels: "⚠ WARNING"⚠ and " CAUTION".

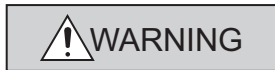

Indicates that incorrect handling may cause hazardous conditions, resulting in death or severe injury.



Indicates that incorrect handling may cause hazardous conditions, resulting in minor or moderate injury or property damage.

Under some circumstances, failure to observe the precautions given under "⚠ CAUTION" may lead to serious consequences.

Observe the precautions of both levels because they are important for personal and system safety.

Make sure that the end users read this manual and then keep the manual in a safe place for future reference.

[Design Precautions]

⚠ WARNING

- In the case of a communication failure in the network, the status of the error station will be as follows:
 - (1) All inputs from remote I/O stations are turned off.
 - (2) All outputs from remote I/O stations are turned off.Check the communication status information and configure an interlock circuit in the sequence program to ensure that the entire system will operate safely. Incorrect output or malfunction due to a communication failure may result in an accident.
- Outputs may remain on or off due to a failure of a remote I/O module. Configure an external circuit for monitoring output signals that could cause a serious accident.
- Do not use any "use prohibited" signals as a remote input or output signal. These signals are reserved for system use. Also do not write any data to the "use prohibited" of the remote register. If such operations are performed, correct operation of the module cannot be guaranteed.

[Design Precautions]

⚠ CAUTION

- Use the module in an environment that meets the general specifications in this manual. Failure to do so may result in electric shock, fire, malfunction, or damage to or deterioration of the product.
- Do not install the control lines or communication cables together with the main circuit lines or power cables. Keep a distance of 100mm or more between them. Failure to do so may result in malfunction due to noise.

[Installation Precautions]

CAUTION

- Do not directly touch any conductive parts of the module. Doing so can cause malfunction or failure of the module.
- Securely fix the module with a DIN rail or mounting screws. Tighten the screws within the specified torque range. Undertightening can cause drop of the screw, short circuit or malfunction. Overtightening can damage the screw and/or module, resulting in drop, short circuit, or malfunction.
- Securely connect the cable connectors. Poor contact may cause malfunction.

[Wiring Precautions]

WARNING

- Shut off the external power supply (all phases) used in the system before wiring. Failure to do so may result in electric shock or cause the module to fail or malfunction.

[Wiring Precautions]

CAUTION

- Individually ground the FG terminal of the programmable controller with a ground resistance of 100Ω or less. Failure to do so may result in electric shock or malfunction.
- Tighten any unused terminal screws within the specified torque range (0.42 to 0.50N·m). Failure to do so may cause a short circuit due to contact with a solderless terminal.
- Use applicable solderless terminals and tighten them within the specified torque range. If any spade solderless terminal is used, it may be disconnected when the terminal screw comes loose, resulting in failure.
- Check the rated voltage and terminal layout before wiring to the module, and connect the cables correctly. Connecting a power supply with a different voltage rating or incorrect wiring may cause a fire or failure.
- Tighten the terminal screw within the specified torque range. Undertightening can cause short circuit, fire, or malfunction. Overtightening can damage the screw and/or module, resulting in drop, short circuit, fire, or malfunction.
- Prevent foreign matter such as dust or wire chips from entering the module. Such foreign matter can cause a fire, failure, or malfunction.
- Place the cables in a duct or clamp them. If not, dangling cable may swing or inadvertently be pulled, resulting in damage to the module or cables or malfunction due to poor contact.
- Attach an unwired connector plug to an unused one-touch connector for power supply and FG. Failure to do so may cause failure or malfunction.
- Do not install the control lines together with the communication cables, or bring them close to each other. Failure to do so may result in malfunction due to noise.

[Wiring Precautions]

CAUTION

- Do not pull the cable part by hand when removing a communication cable and power supply cable from a module. For a cable with connector, remove it while holding the connector by hand. For a cable with no connector, loosen the screw securing the cable to the module and then remove it. Pulling a cable with connected to the module may damage the module or cable, or result in malfunction due to cable poor connection.
- When an overcurrent caused by an error of an external device or a failure of the programmable controller flows for a long time, it may cause smoke and fire. To prevent this, configure an external safety circuit, such as a fuse.
- If a short-circuit occurs, remove the cause immediately. If the short-circuit remains, the internal temperature of the module rises, resulting in malfunction or failure.

[Startup and Maintenance Precautions]

WARNING

- Do not touch any terminal or connector while power is on. Doing so will cause electric shock.
- Shut off the external power supply (all phases) used in the system before cleaning the module or retightening the terminal screws or module mounting screws. Failure to do so may cause the module to fail or malfunction.

[Startup and Maintenance Precautions]

CAUTION

- Do not disassemble or modify the modules. Doing so may cause failure, malfunction, injury, or a fire.
- Do not loosen or tighten the screws on the back of the module. Doing so may disassemble the module and cause failure, resulting in malfunction, injury, or a fire.
- Do not drop or apply strong shock to the module. Doing so may damage the module.
- Shut off the external power supply (all phases) used in the system before mounting or removing a module. Failure to do so may cause the module to fail or malfunction.
- After the first use of the product, do not mount/remove the terminal block to/from the module more than 50 times (IEC 61131-2 compliant).
- Before handling the module, touch a grounded metal object to discharge the static electricity from the human body. Failure to do so may cause the module to fail or malfunction.

[Disposal Precautions]

CAUTION

- When disposing of this product, treat it as industrial waste.

● CONDITIONS OF USE FOR THE PRODUCT ●

- (1) Mitsubishi programmable controller ("the PRODUCT") shall be used in conditions;
 - i) where any problem, fault or failure occurring in the PRODUCT, if any, shall not lead to any major or serious accident; and
 - ii) where the backup and fail-safe function are systematically or automatically provided outside of the PRODUCT for the case of any problem, fault or failure occurring in the PRODUCT.

- (2) The PRODUCT has been designed and manufactured for the purpose of being used in general industries.

MITSUBISHI SHALL HAVE NO RESPONSIBILITY OR LIABILITY (INCLUDING, BUT NOT LIMITED TO ANY AND ALL RESPONSIBILITY OR LIABILITY BASED ON CONTRACT, WARRANTY, TORT, PRODUCT LIABILITY) FOR ANY INJURY OR DEATH TO PERSONS OR LOSS OR DAMAGE TO PROPERTY CAUSED BY the PRODUCT THAT ARE OPERATED OR USED IN APPLICATION NOT INTENDED OR EXCLUDED BY INSTRUCTIONS, PRECAUTIONS, OR WARNING CONTAINED IN MITSUBISHI'S USER, INSTRUCTION AND/OR SAFETY MANUALS, TECHNICAL BULLETINS AND GUIDELINES FOR the PRODUCT.

("Prohibited Application")

Prohibited Applications include, but not limited to, the use of the PRODUCT in;

- Nuclear Power Plants and any other power plants operated by Power companies, and/or any other cases in which the public could be affected if any problem or fault occurs in the PRODUCT.
- Railway companies or Public service purposes, and/or any other cases in which establishment of a special quality assurance system is required by the Purchaser or End User.
- Aircraft or Aerospace, Medical applications, Train equipment, transport equipment such as Elevator and Escalator, Incineration and Fuel devices, Vehicles, Manned transportation, Equipment for Recreation and Amusement, and Safety devices, handling of Nuclear or Hazardous Materials or Chemicals, Mining and Drilling, and/or other applications where there is a significant risk of injury to the public or property.

Notwithstanding the above, restrictions Mitsubishi may in its sole discretion, authorize use of the PRODUCT in one or more of the Prohibited Applications, provided that the usage of the PRODUCT is limited only for the specific applications agreed to by Mitsubishi and provided further that no special quality assurance or fail-safe, redundant or other safety features which exceed the general specifications of the PRODUCTS are required. For details, please contact the Mitsubishi representative in your region.

INTRODUCTION

Thank you for purchasing the Mitsubishi programmable controllers.

This manual describes the specifications, handling, and programming of the CC-Link remote I/O module with diagnostic functions, which is used as a remote device station in a CC-Link system.

The CC-Link remote I/O module with diagnostic functions is an input module equipped with functions that detect disconnection (no connection) or a short-circuit (ground fault) of sensor power supplies.

Before using this product, please read this manual and the relevant manuals carefully and develop familiarity with the functions and performance of the programmable controller to handle the product correctly.

When applying the program examples introduced in this manual to the actual system, ensure the applicability and confirm that it will not cause system control problems.

COMPLIANCE WITH EMC AND LOW VOLTAGE DIRECTIVES

(1) Method of ensuring compliance

To ensure that Mitsubishi programmable controllers maintain EMC and Low Voltage Directives when incorporated into other machinery or equipment, certain measures may be necessary. Please refer to one of the following manuals.

- User's manual for the CPU module or head module used
- Safety Guidelines

(This manual is included with the CPU module, base unit, or head module.)

The CE mark on the side of the programmable controller indicates compliance with EMC and Low Voltage Directives.

(2) Additional measures

To ensure that this product maintains EMC and Low Voltage Directives, please refer to one of the manuals listed under (1).

RELEVANT MANUALS

Manual name <manual number (model code)>	Description
MELSEC-Q CC-Link System Master/Local Module User's Manual <SH-080394E, 13JR64>	System configuration, performance specifications, functions, handling, wiring, and troubleshooting of the CC-Link module
MELSEC-L CC-Link System Master/Local Module User's Manual <SH-080895ENG, 13JZ41>	System configuration, performance specifications, functions, handling, wiring, and troubleshooting of the LCPU with built-in CC-Link and LJ61BT11
MELSEC iQ-R CC-Link System Master/Local Module User's Manual (Application) <SH-081270ENG, 13JX19>	Functions, parameter settings, programming, troubleshooting, I/O signals, and buffer memory of the CC-Link system master/local module
CC-Link System Master/Local Module Type AJ61BT11/A1SJ61BT11 User's Manual <IB-66721, 13J872>	System configuration, performance specifications, functions, handling, wiring, and troubleshooting of the AJ61BT11 and A1SJ61BT11
CC-Link System Master/Local Module Type AJ61QBT11/A1SJ61QBT11 User's Manual <IB-66722, 13J873>	System configuration, performance specifications, functions, handling, wiring, and troubleshooting of the AJ61QBT11 and A1SJ61QBT11
Type AnSHCPU/AnACPU/AnUCPU/QCPU-A (A Mode) Programming Manual (Dedicated Instructions) <IB-66251, 13J742>	Instructions extended for the AnSHCPU/AnACPU/AnUCPU/QCPU-A (A Mode)

CONTENTS

SAFETY PRECAUTIONS	1
CONDITIONS OF USE FOR THE PRODUCT	4
INTRODUCTION	5
COMPLIANCE WITH EMC AND LOW VOLTAGE DIRECTIVES	6
RELEVANT MANUALS	7
MANUAL PAGE ORGANIZATION	10
TERMS	11
PACKING LIST	13
<hr/>	
CHAPTER 1 OVERVIEW	14
<hr/>	
1.1 Features	14
1.2 Identifying the Type	18
<hr/>	
CHAPTER 2 SYSTEM CONFIGURATION	19
<hr/>	
2.1 Overall Configuration	19
2.2 Applicable Systems	20
2.3 How to Check the Version	21
2.4 How to Check the Serial Number ("SERIAL")	21
<hr/>	
CHAPTER 3 PART NAMES	22
<hr/>	
3.1 Transmission Speed Auto-tracking Function	24
<hr/>	
CHAPTER 4 SPECIFICATIONS	25
<hr/>	
4.1 General Specifications	25
4.2 Performance Specifications	26
4.2.1 AJ65ABTP3-16D	26
4.2.2 AJ65ABTP3-16DE	30
4.3 How to Calculate the Current Consumption	34
4.4 Function	36
4.4.1 Function list	36
4.4.2 Input diagnostic function	37
4.4.3 Detection status hold function	44
4.4.4 Checking of the power supply status of an external power supply	46
4.5 Remote I/O Signal	47
4.5.1 List of remote I/O signals	48
4.5.2 Details of remote I/O signals	49
4.6 Remote Register	53
4.6.1 List of remote registers	53
4.6.2 Details of remote registers	54
<hr/>	
CHAPTER 5 PROCEDURES AND SETTINGS BEFORE SYSTEM OPERATION	56
<hr/>	
5.1 Procedures Before Operation	56
5.2 Handling and Installation Precautions	57
5.3 Station Number	59

5.4	Module Installation	60
5.4.1	Installation orientation of the module	60
5.4.2	Installation using a DIN rail	61
5.4.3	Installation using screws	62
5.4.4	Precautions for attaching mounting brackets	63
5.5	Wiring to the Module Power Supply and Data Link Cables	64
5.5.1	Wiring precautions	64
5.5.2	Connection using CC-Link dedicated cables	65
5.5.3	Connection to the module power supply and data link cables	66
5.5.4	List of one-touch connector plugs	68
5.5.5	Wiring procedures for the one-touch connector for communication.	69
5.5.6	Wiring procedures for the one-touch connector for power supply and FG.	72
5.6	Wiring to the External Power Supply and Input Signals	75
5.6.1	Wiring precautions	77
5.6.2	Installation and removal of the spring clamp terminal block (push-in type)	78
5.7	Maintenance and Inspection.	80

CHAPTER 6 PROGRAMMING	81
------------------------------	-----------

6.1	Programming Procedure.	81
6.2	Conditions Used for Program Examples.	82
6.3	Program Example When the QCPU (Q Mode) is Used	84
6.4	Program Example When the LCPU is Used	94
6.5	Program Example When the QnACPU is Used	99
6.6	Program Example When the ACPUCPU (A Mode) is Used (Dedicated Instructions)	104
6.7	Program Example When the ACPUCPU (A Mode) is Used (FROM/TO Instructions)	109

CHAPTER 7 TROUBLESHOOTING	114
----------------------------------	------------

7.1	How to Check for Errors with LED Indications	114
7.2	Troubleshooting by Situation	116
7.3	Troubleshooting When the "ERR." LED of the Master Station Flashes	117
7.4	Examples of Errors for the CC-Link Remote I/O Module with Diagnostic Functions	119
7.4.1	Errors that may occur in the input circuit and the corrective actions	119

APPENDIX	122
-----------------	------------

Appendix 1 External Dimensions	122
--	-----

INDEX	125
--------------	------------

REVISIONS	127
WARRANTY	128

MANUAL PAGE ORGANIZATION

In this manual, pages are organized and the symbols are used as shown below.
The following page illustration is for explanation purpose only, and is different from the actual pages.

Diagram illustrating the organization of a manual page (7.1.1 Setting method) and the symbols used to denote specific elements:

- ""** is used for screen names and items.
- 1.** shows operating procedures.
- []** is used for items in the menu bar and the project window.
- Ex.** shows setting or operating examples.
- []** shows reference manuals.
- []** shows reference pages.
- Point** shows notes that require attention.
- Remark** shows useful information.

The diagram also shows the page structure: CHAPTER 7 VARIOUS SETTINGS, 7.1.1 Setting method, and a table with columns Item, Description, and Reference.

Item	Description	Reference
Type	Select the type of the connected module.	Page 74, Section 7.1.2
Model Name	Select the model name of the connected module.	Page 74, Section 7.1.3
Points	Set the number of points assigned to each slot.	Page 74, Section 7.1.4
Start XY	Specify a start I/O number for each slot.	Page 74, Section 7.1.5
[Switch Setting]	Configure the switch setting of the built-in I/O or intelligent function modules.	Page 74, Section 7.1.6
[General Setting]	Set the following: - Error Time Output Mode - PLC Operation Mode at HW Error - I/O Response Time	Page 75, Section 7.1.7

*1 The mouse operation example is provided below. (For GX Works2)

Diagram illustrating the software interface (MELSOFT Series GX Works2) and the symbols used to denote specific elements:

- Menu bar**: [Online] → [Write to PLC...]. Select [Online] on the menu bar, and then select [Write to PLC...].
- A window selected in the view selection area is displayed.**: Project window → [Parameter] → [PLC Parameter]. Select [Project] from the view selection area to open the Project window. In the Project window, expand [Parameter] and select [PLC Parameter].
- View selection area**: Project, User Library, Connection Destination.

TERMS

This manual uses the following generic terms and abbreviations to describe the CC-Link remote I/O module with diagnostic functions, unless otherwise specified.

Term	Description
CC-Link remote I/O module with diagnostic functions	A generic term for the CC-Link remote I/O module equipped with input diagnostic functions. The functions are used to detect disconnection (no connection) or a short-circuit (ground fault) of sensor power supplies.
GX Developer GX Works2	The product name of the software package for the MELSEC programmable controllers
QCPU (Q mode)	A generic term for the following CPU modules: Q00JCPU, Q00CPU, Q00UJCPU, Q00UCPU, Q01CPU, Q01UCPU, Q02CPU, Q02HCPU, Q02PHCPU, Q02UCPU, Q03UDCPU, Q03UDVCPU, Q03UDECPU, Q04UDHCPU, Q04UDVCPU, Q04UDEHCPU, Q06HCPU, Q06PHCPU, Q06UDHCPU, Q06UDVCPU, Q06UDEHCPU, Q10UDHCPU, Q10UDEHCPU, Q12HCPU, Q12PHCPU, Q12PRHCPU, Q13UDHCPU, Q13UDVCPU, Q13UDEHCPU, Q20UDHCPU, Q20UDEHCPU, Q25HCPU, Q25PHCPU, Q25PRHCPU, Q26UDHCPU, Q26UDVCPU, Q26UDEHCPU, Q50UDEHCPU, and Q100UDEHCPU
QCPU (A mode)	A generic term for the Q02CPU-A, Q02HCPU-A, and Q06HCPU-A
LCPU	A generic term for the following CPU modules: L02SCPU, L02SCPU-P, L02CPU, L02CPU-P, L06CPU, L06CPU-P, L26CPU, L26CPU-P, L26CPU-BT, and L26CPU-PBT
RCPU	A generic term for R04CPU, R08CPU, R16CPU, R32CPU, and R120CPU
QnACPU	A generic term for the following CPU modules: Q2ACPU, Q2ACPU-S1, Q2ASCPU, Q2ASCPU-S1, Q2ASHCPU, Q2ASHCPU-S1, Q3ACPU, Q4ACPU, and Q4ARCPU
ACPU	A generic term for the following CPU modules: A0J2CPU, A0J2HCPU, A1CPU, A2CPU, A2CPU-S1, A3CPU, A1SCPU, A1SCPUC24-R2, A1SHCPU, A1SJCPU, A1SJCPU-S3, A1SJHCPU, A1NCP, A2NCP, A2NCP-S1, A3NCP, A3MCP, A3HCP, A2SCP, A2SHCP, A2ACP, A2ACP-S1, A3ACP, A2UCP, A2UCP-S1, A2USCP, A2USCP-S1, A2USHCP-S1, A3UCP, and A4UCP
Master station	A station that controls a data link system One master station is required for one system.
Local station	A station that includes a CPU module and can communicate with the master station and other local stations
Remote I/O station	A station that exchanges I/O signals (bit data) and I/O data (word data) with an external device, and converts analog data into digital data
Remote device station	A station that exchanges I/O signals (bit data) and I/O data (word data) with an external device, and converts analog data into digital data
Remote station	A generic term for a remote I/O station and a remote device station
Intelligent device station	A station, such as the AJ65BT-R2N, that can perform transient transmission. (Local stations are included.)
Master module	A generic term for modules that can serve as a master station
SB	Link special relay (for CC-Link) Bit data that indicates the operating status and data link status of modules on the master and local stations
SW	Link special register (for CC-Link) Word data that indicates the operating status and data link status of modules on the master and local stations
RX	Remote input (for CC-Link) Bit data input from a remote station to the master station
RY	Remote output (for CC-Link) Bit data output from the master station to a remote station

Term	Description
RWw	Remote register (write area for CC-Link) Word data output from the master station to a remote device station
RWr	Remote register (read area for CC-Link) Word data input from a remote device station to the master station

PACKING LIST

The items in the following tables are included in the package of each product.

(1) AJ65ABTP3-16D

Product name	Quantity
AJ65ABTP3-16D 24VDC input module with diagnostic functions (positive common/sink type)	1
AJ65ABTP3-16D 24VDC Input Module With Diagnostic Functions (Positive Common/Sink Type) User's Manual	1
Mounting bracket	2

(2) AJ65ABTP3-16DE

Product name	Quantity
AJ65ABTP3-16DE 24VDC input module with diagnostic functions (negative common/source type)	1
AJ65ABTP3-16DE 24VDC Input Module With Diagnostic Functions (Negative Common/Source Type) User's Manual	1
Mounting bracket	2

CHAPTER 1 OVERVIEW

1.1 Features

This section describes the features of the CC-Link remote I/O module with diagnostic functions.

(1) Increasing maintainability by using diagnostic functions

The disconnection (no connection) or short-circuit (ground) of an input wiring (sensor power supply) can be detected by each point.

(a) Check for disconnections (no connections) or short-circuits (ground) with LED indications

The LEDs of the module indicate the disconnections (no connections) or short-circuits (grounds).

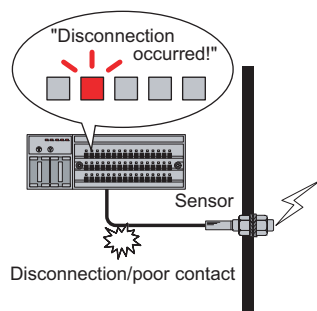

(b) Notification of disconnections (no connections) or short-circuits (ground) to the master module

The locations and the causes are notified to the master station. The disconnections (no connections) or short-circuits (ground) can be checked by using the module in combination with HMI (Human Machine Interface) such as GOT.

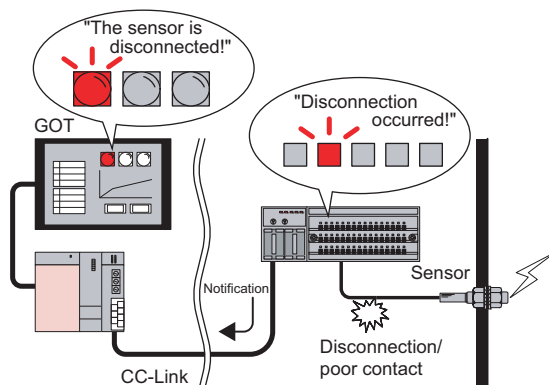

(2) Enabling/disabling of the disconnection (no connection) detection function can be set.

Whether to enable or disable the disconnection (no connection) detection function can be set by each point. By using this setting, the detection function of the disconnection (no connection), where the input point is not used, can be disabled.

Note that the detection function of the short-circuit (ground) is always enabled at all points.

(3) Check for wiring errors by monitoring an external power supply

An input common power supply status (whether the power is on or off) can be checked.

(a) Check of the power supply status of an external power supply with LED indications

The LEDs of the module indicate the power supply status of an external power supply.

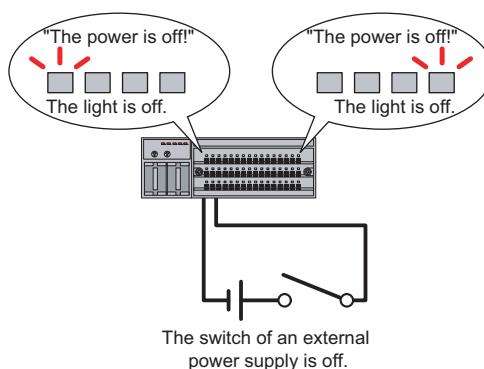

(b) Notification of the power supply status of an external power supply to the CPU module

The power supply status of an external power supply is notified to the CPU module. The status can be checked by using the module in combination with HMI (Human Machine Interface) such as GOT.

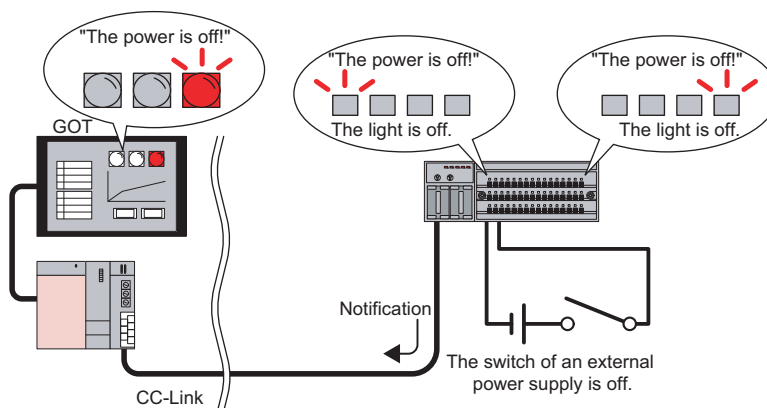

(4) Visualization of the wiring status by using a sequence program

By counting the number of disconnections, wiring disconnections (no connections) or poor contacts can be visualized. This visualization enables to detect wiring errors early and perform preventive maintenance.

(5) Capable of preventing the misjudgment of the module when a ground occurs (AJ65ABTP3-16DE only)

Because the input type of the AJ65ABTP3-16DE is negative common (source type), the module's misjudgment (mistaking the ground of an input signal for a normal status) can be prevented.

(6) A variety of installation methods

The way of the module installation can be chosen between "installation using a DIN rail" and "installation using screws", depending on the installation environment. The location of the screws can be chosen from three patterns.

Also, the module can be installed in six different orientations as shown below.

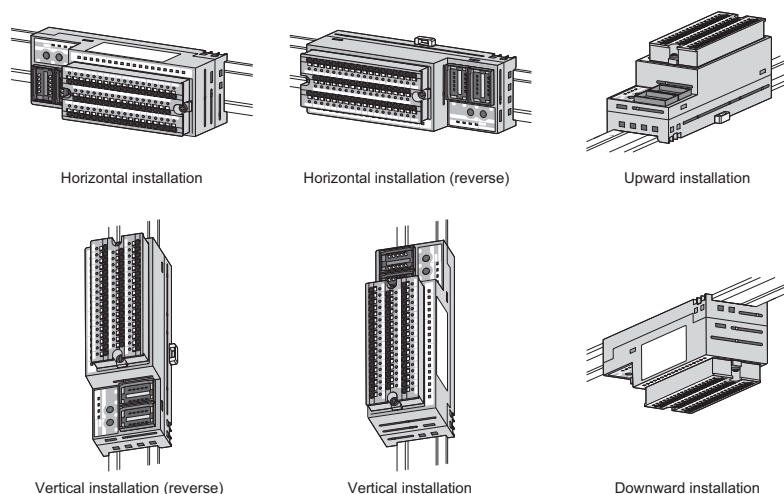

(7) The switch setting of the transmission speed is not required.

After the power is supplied, the module senses a transmission speed in network communications and set the transmission speed automatically. Due to this function, the switch settings of the transmission speed at remote stations are not required and therefore the man-hour for starting the system can be reduced.

(8) Easy setting of the station number

The station number can be set easily with a rotary switch.

(9) Man-hour reduction for wiring

- Because a terminal block of the module has a spring clamp structure (push-in type), a solderless terminal can be connected by inserting it in the pin. Therefore tightening screws is not required at the time of maintenance.
- Because one-touch connectors (pressure-displacement wire-connection method) are used to connect communication cables or power cables, soldering, stripping wires, and tightening screws are not required.

(10)Simplifying wiring procedures

- Because separate one-touch connectors are used for IN side connection and OUT side connection, transition wiring in the panel can be configured easily.
- I/O power terminals for transition wiring are installed on both ends of the terminal block. Therefore, to connect multiple numbers of the CC-Link remote I/O modules with diagnostic functions, installation of a relay terminal block between the modules is not required.
- A 2-wire or 3-wire sensor can be directly connected to the terminal block. Therefore, installation of a relay terminal block between the CC-Link remote I/O module with diagnostic functions and the sensor is not required.
- Because a 2-piece structure is used for an input wiring part, the module can be changed with the input wiring connected to the terminal block. The 2-piece terminal block can be easily removed by loosening the fixing screws, because the terminal block is lifted by doing so.

(11)Wiring check can be done easily.

Wiring check can be done easily by using the conduction check hole on the 2-piece terminal block. Incorrect wiring can be detected early.

1.2 Identifying the Type

This section shows how to identify the type of a CC-Link remote I/O module with diagnostic functions.

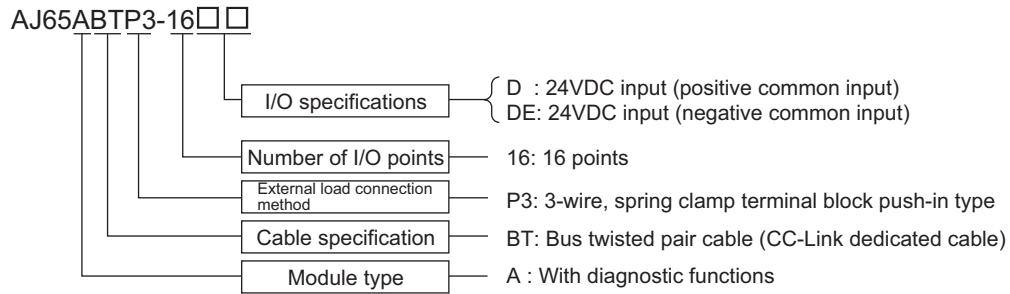

CHAPTER 2 SYSTEM CONFIGURATION

This chapter explains the system configuration when the CC-Link remote I/O module with diagnostic functions is used.

2

2.1 Overall Configuration

This section shows the overall configuration when the CC-Link remote I/O module with diagnostic functions is used.

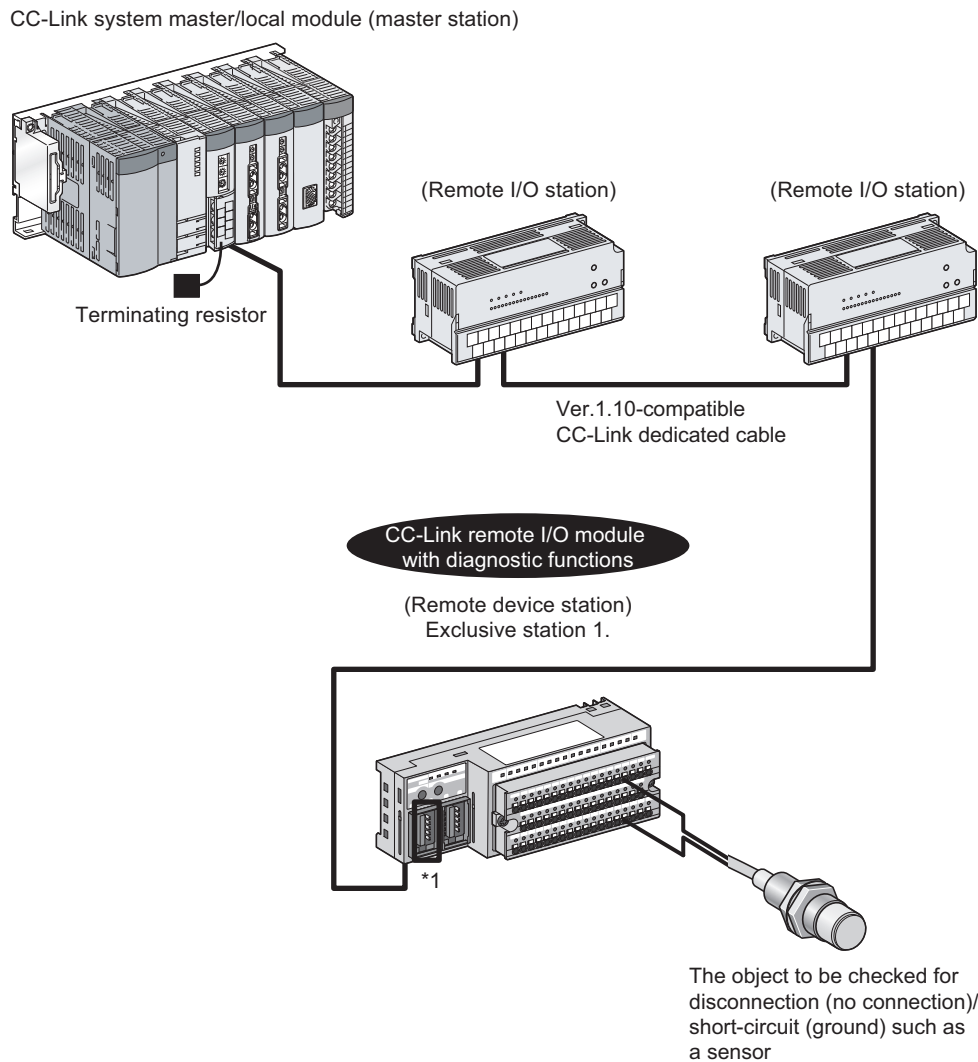

- *1 When the module is used at the end of the CC-Link system, attach an one-touch connector plug with terminating resistor (A6CON-TR11(N)) to the module. (☞ Page 68, Section 5.5.4)

2.2 Applicable Systems

Master modules listed on the website of CC-Link Partner Association (CLPA) are applicable to the system.
For more details, visit the following URL.
CC-Link Partner Association: www.cc-link.org

Remark

Check the specifications of master modules of each manufacturer before using them.

(1) Precautions for setting parameters

Because the CC-Link remote I/O module with diagnostic functions is used as a remote device station, its parameter settings are different from those of a CC-Link remote I/O module.

For the parameter settings of a remote device station, refer to the user's manual for the master module to be used.

(2) Restrictions when using the CC-Link dedicated instructions (RLPA, RRPA)

The CC-Link dedicated instructions (RLPA, RRPA) might not be able to use depending on the CPU module or master module to be used.

For details on the restrictions, refer to the user's manuals for the A series master modules, and Type AnSHCPU/AnACPU/AnUCPU/QCPU-A (A Mode) Programming Manual (Dedicated Instructions).

The dedicated instructions except RLPA and RRPA cannot be used for the CC-Link remote I/O module with diagnostic functions.

For the program examples when the dedicated instructions (RLPA, RRPA) are used, refer to the "Program Example When the ACPUCPU/QCPU (A Mode) is Used (Dedicated Instructions)" section. (☞ Page 104, Section 6.6)

2.3 How to Check the Version

The hardware version and the software version of the CC-Link remote I/O module with diagnostic functions can be checked on the rating plate ("DATE").

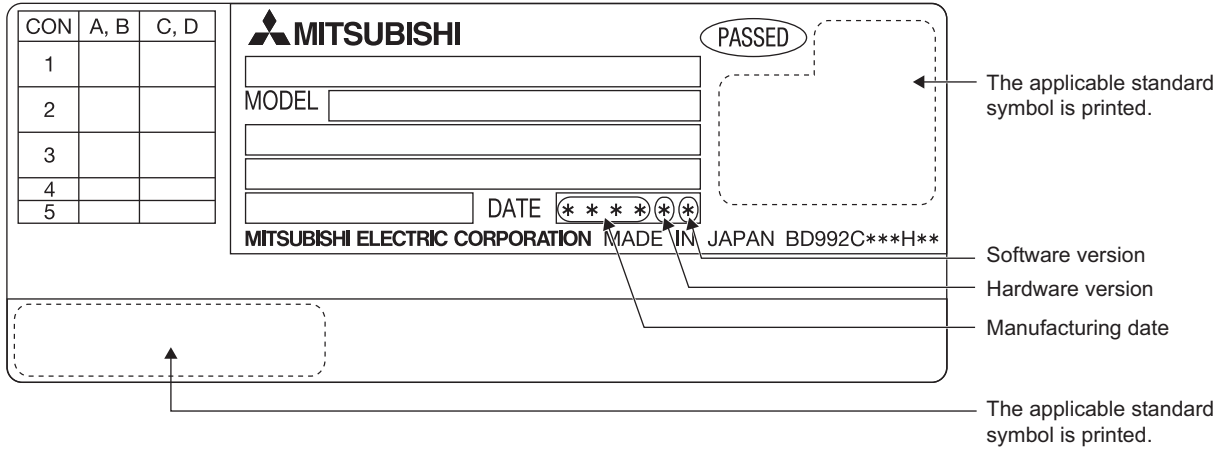

2.4 How to Check the Serial Number ("SERIAL")

The serial number of the CC-Link remote I/O module with diagnostic functions can be checked on the rating plate ("SERIAL").

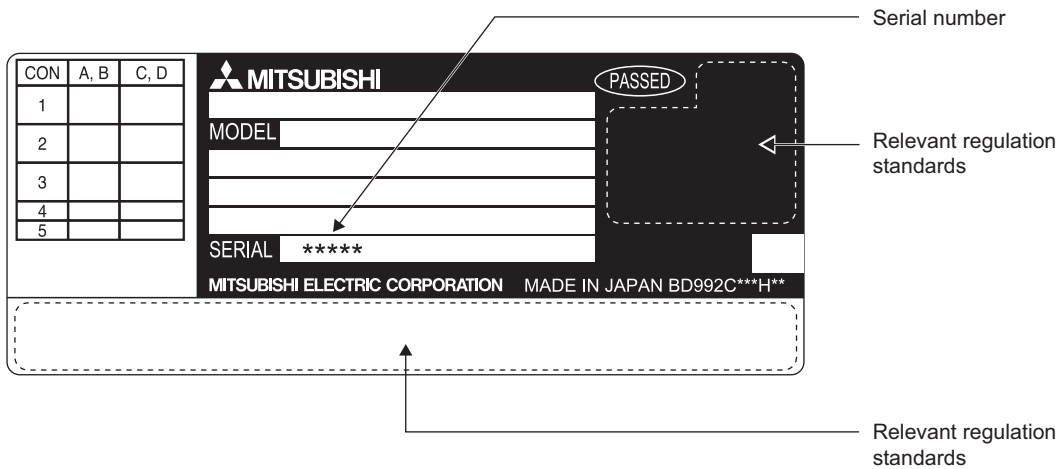

CHAPTER 3 PART NAMES

This chapter lists the components of the CC-Link remote I/O module with diagnostic functions.

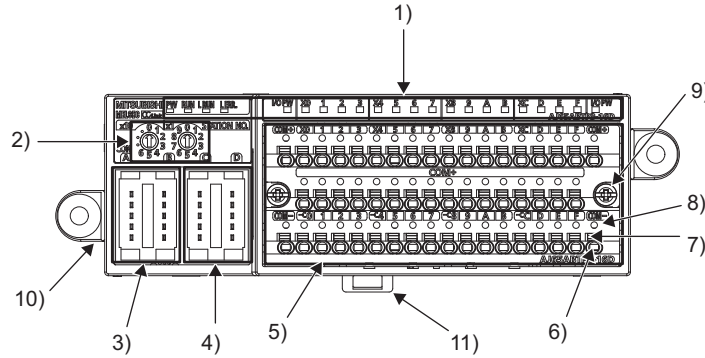

No.	Item	Description		
1)	Operating status indication LED	PW LED	Green	Indicates the power supply status of the module. ON: Power being supplied OFF: No power supplied
		RUN LED	Green	Indicates the operating status of the remote I/O module. ON: Normal operation OFF: A watchdog timer error occurs.
		L RUN LED	Green	Indicates the status of data communication between the remote I/O module and the master module. ON: Normal communication OFF: No communication (timeout error)
		L ERR. LED	Red	Indicates the status of data communication error between the remote I/O module and the master module. ON: The station number is set outside the range. Flashing regularly: The station number is changed during the operation.*1 Flashing irregularly: A terminating resistor is not installed. The module or CC-Link dedicated cable is affected by noise. OFF: Normal communication
		I/O PW LED	Green	Indicates the status of the external power supply. ON: Supplying power OFF: Not supplying power
		X0 to XF	Green*2	Indicates the ON/OFF status of input. ON: Input ON OFF: Input OFF
Red*3	Indicates the disconnection, no connection, short-circuit, or ground of the input. Flashing: Disconnection or no connection occurs.*4 ON: A short-circuit or a ground occurs.*4			
2)	Station number setting switch	A rotary switch to set a station number If a number other than 1 to 64 is set, an error occurs and "L ERR." LED turns on. Note that a unique station number should be set. <ul style="list-style-type: none"> • Set the tens place of the number to x10. • Set the ones place of the number to x1. 		

No.	Item	Description
3)	One-touch connector for communication	One-touch connector for communication line When the module is used at the end of the CC-Link system, attach a one-touch connector plug with terminating resistor (A6CON-TR11(N)) to the module.
4)	One-touch connector for power supply and FG	One-touch connector for module power supply line and FG
5)	Spring clamp terminal block (push-in type)	2-piece spring clamp terminal block (push-in type) for input signals To install or remove the terminal block, refer to the "Installation and removal of the spring clamp terminal block (push-in type)" section. (☞ Page 78, Section 5.6.2) For terminal layout of the AJ65ABTP3-16D, refer to the "AJ65ABTP3-16D" in the "Performance Specifications" section. (☞ Page 26, Section 4.2.1) For terminal layout of the AJ65ABTP3-16DE, refer to the "AJ65ABTP3-16DE" in the "Performance Specifications" section. (☞ Page 30, Section 4.2.2)
6)	Pin	A bar solderless terminal is connected by inserting it into the pin. For applicable wire size, refer to the "Performance Specifications" section. (☞ Page 26, Section 4.2)
7)	Open/close button	A bar solderless terminal can be pulled out by pressing this button using a commercially available tool. (A dedicated tool is not required.)
8)	Conduction check hole	The connection of a wire can be checked by inserting a tester in this hole. (Applicable check pin size of the tester: $\phi 2\text{mm}$, sharp angle)
9)	2-piece terminal block fixing screw	Used to fix the terminal block to a module. M3 screw (tightening torque range: 0.42 to 0.57N•m)
10)	Mounting bracket (accessory)	Used to install the module to a control panel. The bracket can be removed. M4 screw (tightening torque range: 0.82 to 1.11N•m)
11)	DIN rail hook	Used to mount the module to a DIN rail.

*1 If the station number is changed while communication is disconnected, the LED starts flashing irregularly.

*2 If the disconnection (no connection) or the short-circuit (ground) occurs, the red LED (indication of abnormal status) preferentially turns on. Therefore, the green LED (indication of ON/OFF status of input) does not turn on.

*3 The red LED is flashing/on during the occurrence of the disconnection (no connection) or the short-circuit (ground). To keep the LED flashing/on, set Disconnection indication command (RWwm + 2_H) and Short-circuit indication command (RWwm + 3_H).

*4 If "Turn on the LED (1)" is set to Short-circuit indication command (RWwm + 3_H) while "Flash the LED regularly (1)" is set to Disconnection indication command (RWwm + 2_H), Short-circuit indication command (RWwm + 3_H) is prioritized and the red LED turns on.

3.1 Transmission Speed Auto-tracking Function

The transmission speed setting to the CC-Link remote I/O module with diagnostic functions is not required because the speed is automatically set according to the setting of the master module.

CHAPTER 4 SPECIFICATIONS

This chapter lists the specifications of the CC-Link remote I/O module with diagnostic functions.

4.1 General Specifications

The following table lists the general specifications of the CC-Link remote I/O module with diagnostic functions.

Item	Specifications					
Operating ambient temperature	0 to 55°C					
Storage ambient temperature	-20 to 75°C					
Operating ambient humidity	10 to 90% RH, No-condensing					
Storage ambient humidity						
Vibration resistance	Compliant with JIS B 3502 and IEC 61131-2	Under intermittent vibration	Frequency	Constant acceleration	Half amplitude	Sweep count
			5 to 8.4Hz	-	3.5mm	10 times each in X, Y, Z directions.
		Under continuous vibration	8.4 to 150Hz	9.8m/s ²	-	
			5 to 8.4Hz	-	1.75mm	
8.4 to 150Hz	4.9m/s ²	-				
Shock resistance	Compliant with JIS B 3502 and IEC 61131-2 (147m/s ² , 3 times each in 3 directions X, Y, Z)					
Operating atmosphere	No corrosive gases					
Operating altitude ^{*1}	0 to 2000m					
Installation location	Inside a control panel					
Overvoltage category ^{*2}	II or less					
Pollution degree ^{*3}	2 or less					

- *1 Do not use or store the programmable controller under pressure higher than the atmospheric pressure of altitude 0m. Doing so may cause malfunction. When using the programmable controller under pressure, please consult your local Mitsubishi representative.
- *2 This indicates the section of the power supply to which the equipment is assumed to be connected between the public electrical power distribution network and the machinery within premises.
Category II applies to equipment for which electrical power is supplied from fixed facilities. The surge voltage withstand level for up to the rated voltage of 300V is 2500V.
- *3 This index indicates the degree to which conductive material is generated in terms of the environment in which the equipment is used.
Pollution level 2 is when only non-conductive pollution occurs. A temporary conductivity caused by condensing must be expected occasionally.

4.2 Performance Specifications

This section lists the performance specifications of the CC-Link remote I/O module with diagnostic functions.

4.2.1 AJ65ABTP3-16D

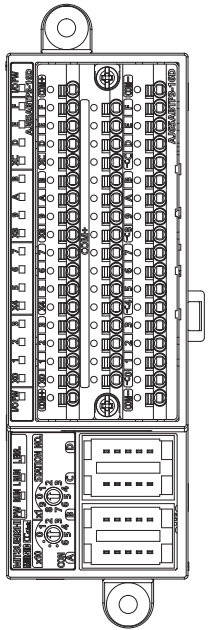
Item		AJ65ABTP3-16D	Appearance
CC-Link Ver.		CC-Link Ver.1.10	
CC-Link station type		Remote device station	
Number of input points		16 points	
Isolation method		Photocoupler	
Rated input voltage		24VDC (ripple ratio: within 5%)	
Rated input current		Approx. 6mA	
Operating voltage range		20.4 to 28.8VDC	
Max. number of simultaneous input points		100%	
ON voltage/ON current		14V or higher/3.5mA or higher	
OFF voltage/OFF current		6V or lower/1.7mA or lower	
Input resistance		Approx. 3.8kΩ	
Response time	OFF→ON	1.5ms or less (at 24VDC)	
	ON→OFF	1.5ms or less (at 24VDC)	
Wiring method for common		16 points/common (3-wire, spring clamp terminal block push-in type)	
Input type		Positive common (sink type)	
Number of occupied stations		32-point assignment/station (16 points used)	
Internal circuit power supply for input part	Voltage	24VDC (ripple ratio: within 5%) (allowable voltage range: 20.4 to 28.8VDC)	
	Current	30mA or lower (at 24VDC and all points ON), excluding external load current	
I/O power supply current		8A or lower/common*1	
Short-circuit (ground) detection current		50mA or higher/point	
Disconnection (no connection) detection current		0.3mA or lower/point	
Module power supply	Voltage	24VDC (ripple ratio: within 5%) (allowable voltage range: 20.4 to 26.4VDC)	
	Current	55mA or lower (at 24VDC and all points ON)	
Noise immunity		Noise voltage 500Vp-p, noise width 1μs, noise frequency 25 to 60Hz (DC type noise simulator condition)	
Withstand voltage		500VAC for 1 minute between all DC external terminals and ground	
Insulation resistance		10MΩ or higher between all DC external terminals and ground (500VDC insulation resistance tester)	
Protection degree		IP1XB	
External dimensions		50(H)×145(W)×57.5(D)mm	
Weight		0.31kg	

*1 When supplying the power to multiple modules in a transition wiring system, calculate the current consumption by referring to the "How to Calculate the Current Consumption" section. (Page 34, Section 4.3)

Item		AJ65ABTP3-16D
External connection system	Communication part	One-touch connector for communication [Transmission circuit] 5-pin IDC plug is sold separately: A6CON-L5P <Optional>Online connector for communication: A6CON-LJ5P
	Power supply part	One-touch connector for power supply and FG [Module power supply, FG] 5-pin IDC plug is sold separately: A6CON-PW5P, A6CON-PW5P-SOD <Optional>Online connector for power supply: A6CON-PWJ5P
	Input part	2-piece spring clamp terminal block push-in type [I/O power supply, I/O signals]
Module mounting screw		2-M4 screw (tightening torque range: 0.82 to 1.11 N·m) Mountable with a DIN rail in 6 orientations
Applicable DIN rail		TH35-7.5Fe, TH35-7.5Al (compliant with IEC 60715)
Applicable wire size	Connector for communication	Applicable cable: FANC-110SBH, CS-110
	Connector for power supply and FG	0.66 to 0.98mm ² (18 AWG) [φ2.2 to 3.0mm (A6CON-PW5P), φ2.0 to 2.3mm (A6CON-PW5P-SOD)] Wire diameter: 0.16mm or more Insulating coating material: PVC (heat-resistant) Maximum rated current: 7A ^{*2}
	Spring clamp terminal block for input	Stranded wire 0.08 to 1.5mm ² (28 to 16 AWG) ^{*3}
	Applicable solderless terminal	TE 0.5-8, TE 0.5-10 [Applicable wire size: 0.5mm ²] (NICHIFU TERMINAL INDUSTRIES CO.,LTD) TE 0.75-8, TE 0.75-10 [Applicable wire size: 0.75mm ²] (NICHIFU TERMINAL INDUSTRIES CO.,LTD) TE 1.0-8, TE 1.0-10 [Applicable wire size: 0.9 to 1.0mm ²] (NICHIFU TERMINAL INDUSTRIES CO.,LTD) TE 1.5-8, TE 1.5-10 [Applicable wire size: 1.25 to 1.5mm ²] (NICHIFU TERMINAL INDUSTRIES CO.,LTD) AI 0.25-12BU [Applicable wire size: 0.25mm ²] (PHOENIX CONTACT) AI 0.34-8TQ, AI 0.34-12TQ [Applicable wire size: 0.34mm ²] (PHOENIX CONTACT) AI 0.5-8WH, AI 0.5-10WH [Applicable wire size: 0.5mm ²] (PHOENIX CONTACT) AI 0.75-8GY, AI 0.75-10GY [Applicable wire size: 0.75mm ²] (PHOENIX CONTACT) AI 1-8RD, AI 1-10RD [Applicable wire size: 1.0mm ²] (PHOENIX CONTACT) AI 1.5-8BK, AI 1.5-10BK [Applicable wire size: 1.5mm ²] (PHOENIX CONTACT)

*2 Keep the current within the allowable range of the connected cable.

*3 Insert only one wire into the pin of the spring clamp terminal block.
Inserting two or more wires may result in a poor contact to the terminal.

External connection

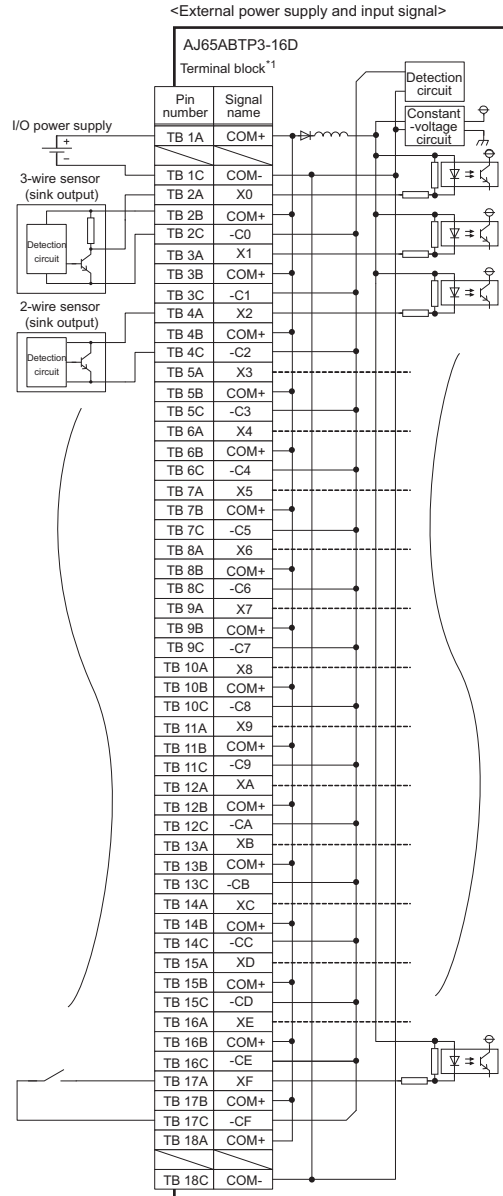
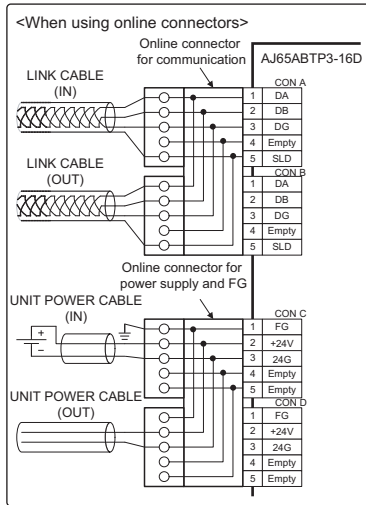
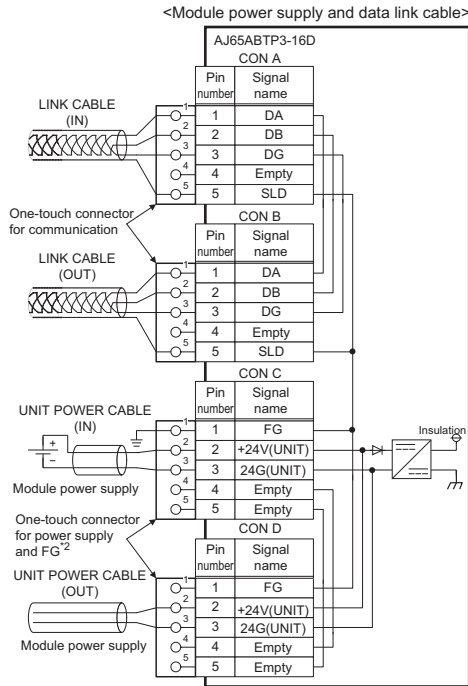

- *1 Insert only one wire into the pin of the spring clamp terminal block.
Inserting two or more wires may result in a poor contact to the terminal.
- *2 Attach an unwired connector plug to an unused one-touch connector for power supply and FG.

External connection

■ Signal array of connector

Pin number	Connector			
	CON A	CON B	CON C	CON D
1	DA		FG	
2	DB		+24V(UNIT)	
3	DG		24G(UNIT)	
4	Empty		Empty	
5	SLD		Empty	

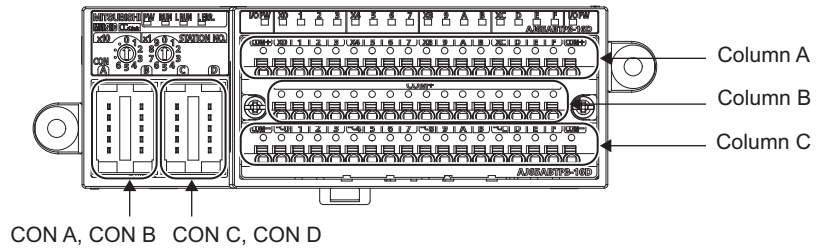

■ Terminal layout of terminal block

Terminal block	Pin number																	
	1	2	3	4	5	6	7	8	9	10	11	12	13	14	15	16	17	18
Column A	COM+ _{*3}	X0	X1	X2	X3	X4	X5	X6	X7	X8	X9	XA	XB	XC	XD	XE	XF	COM+ _{*3}
Column B		COM+	COM+	COM+	COM+	COM+	COM+	COM+	COM+	COM+	COM+	COM+	COM+	COM+	COM+	COM+	COM+	
Column C	COM- _{*3}	-C0	-C1	-C2	-C3	-C4	-C5	-C6	-C7	-C8	-C9	-CA	-CB	-CC	-CD	-CE	-CF	COM- _{*3}

*3 For I/O power supply, use 1A and 1C pins of a spring clamp terminal block for input. For transition wiring of I/O power supply, use the 18A and 18C pins.

4.2.2 AJ65ABTP3-16DE

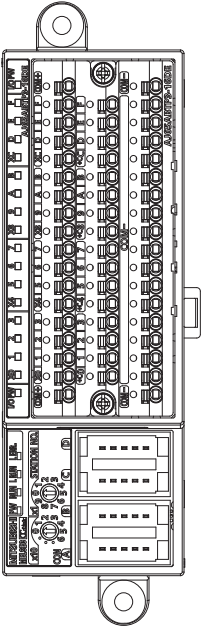
Item		AJ65ABTP3-16DE	Appearance
CC-Link Ver.		CC-Link Ver. 1.10	
CC-Link station type		Remote device station	
Number of input points		16 points	
Isolation method		Photocoupler	
Rated input voltage		24VDC (ripple ratio: within 5%)	
Rated input current		Approx. 6mA	
Operating voltage range		20.4 to 28.8VDC	
Max. number of simultaneous input points		100%	
ON voltage/ON current		14V or higher/3.5mA or higher	
OFF voltage/OFF current		6V or lower/1.7mA or lower	
Input resistance		Approx. 3.8kΩ	
Response time	OFF→ON	1.5ms or less (at 24VDC)	
	ON→OFF	1.5ms or less (at 24VDC)	
Wiring method for common		16 points/common (3-wire, spring clamp terminal block push-in type)	
Input type		Negative common (source type)	
Number of occupied stations		32-point assignment/station (16 points used)	
Internal circuit power supply for input part	Voltage	24VDC (ripple ratio: within 5%) (allowable voltage range: 20.4 to 28.8VDC)	
	Current	30mA or lower (at 24VDC and all points ON), excluding external load current	
I/O power supply current		4A or lower/common ^{*1}	
Short-circuit (ground) detection current		50mA or higher/point	
Disconnection (no connection) detection current		0.3mA or lower/point	
Module power supply	Voltage	24VDC (ripple ratio: within 5%) (allowable voltage range: 20.4 to 26.4VDC)	
	Current	60mA or lower (at 24VDC and all points ON)	
Noise immunity		Noise voltage 500Vp-p, noise width 1μs, noise frequency 25 to 60Hz (DC type noise simulator condition)	
Withstand voltage		500VAC for 1 minute between all DC external terminals and ground	
Insulation resistance		10MΩ or higher between all DC external terminals and ground (500VDC insulation resistance tester)	
Protection degree		IP1XB	
External dimensions		50(H)×145(W)×57.5(D)mm	
Weight		0.31kg	

*1 When supplying the power to multiple modules in a transition wiring system, calculate the current consumption by referring to the "How to Calculate the Current Consumption" section. (☞ Page 34, Section 4.3)

Item		AJ65ABTP3-16DE
External connection system	Communication part	One-touch connector for communication [Transmission circuit] 5-pin IDC plug is sold separately: A6CON-L5P <Optional>Online connector for communication: A6CON-LJ5P
	Power supply part	One-touch connector for power supply and FG [Module power supply, FG] 5-pin IDC plug is sold separately: A6CON-PW5P, A6CON-PW5P-SOD <Optional>Online connector for power supply: A6CON-PWJ5P
	Input part	2-piece spring clamp terminal block push-in type [I/O power supply, I/O signals]
Module mounting screw		2-M4 screw (tightening torque range: 0.82 to 1.11 N·m) Mountable with a DIN rail in 6 orientations
Applicable DIN rail		TH35-7.5Fe, TH35-7.5Al (compliant with IEC 60715)
Applicable wire size	Connector for communication	Applicable cable: FANC-110SBH, CS-110
	Connector for power supply and FG	0.66 to 0.98mm ² (18 AWG) [φ2.2 to 3.0mm (A6CON-PW5P), φ2.0 to 2.3mm (A6CON-PW5P-SOD)] Wire diameter: 0.16mm or more Insulating coating material: PVC (heat-resistant) Maximum rated current: 7A ^{*2}
	Spring clamp terminal block for input	Stranded wire 0.08 to 1.5mm ² (28 to 16 AWG) ^{*3}
	Applicable solderless terminal	TE 0.5-8, TE 0.5-10 [Applicable wire size: 0.5mm ²] (NICHIFU TERMINAL INDUSTRIES CO.,LTD) TE 0.75-8, TE 0.75-10 [Applicable wire size: 0.75mm ²] (NICHIFU TERMINAL INDUSTRIES CO.,LTD) TE 1.0-8, TE 1.0-10 [Applicable wire size: 0.9 to 1.0mm ²] (NICHIFU TERMINAL INDUSTRIES CO.,LTD) TE 1.5-8, TE 1.5-10 [Applicable wire size: 1.25 to 1.5mm ²] (NICHIFU TERMINAL INDUSTRIES CO.,LTD) AI 0.25-12BU [Applicable wire size: 0.25mm ²] (PHOENIX CONTACT) AI 0.34-8TQ, AI 0.34-12TQ [Applicable wire size: 0.34mm ²] (PHOENIX CONTACT) AI 0.5-8WH, AI 0.5-10WH [Applicable wire size: 0.5mm ²] (PHOENIX CONTACT) AI 0.75-8GY, AI 0.75-10GY [Applicable wire size: 0.75mm ²] (PHOENIX CONTACT) AI 1-8RD, AI 1-10RD [Applicable wire size: 1.0mm ²] (PHOENIX CONTACT) AI 1.5-8BK, AI 1.5-10BK [Applicable wire size: 1.5mm ²] (PHOENIX CONTACT)

*2 Keep the current within the allowable range of the connected cable.

*3 Insert only one wire into the pin of the spring clamp terminal block.
Inserting two or more wires may result in a poor contact to the terminal.

External connection

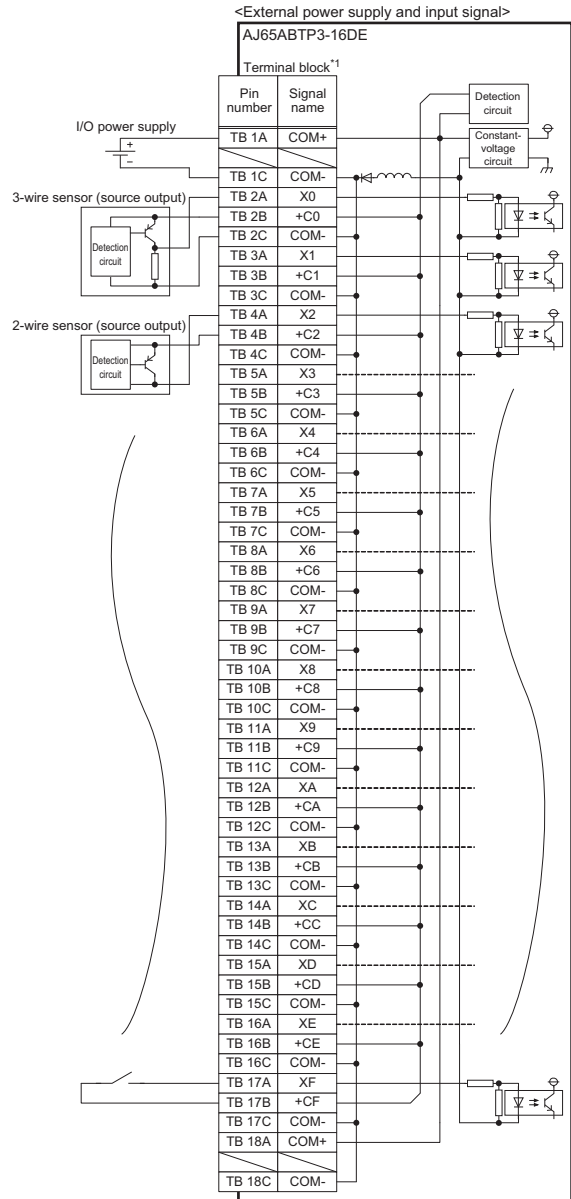
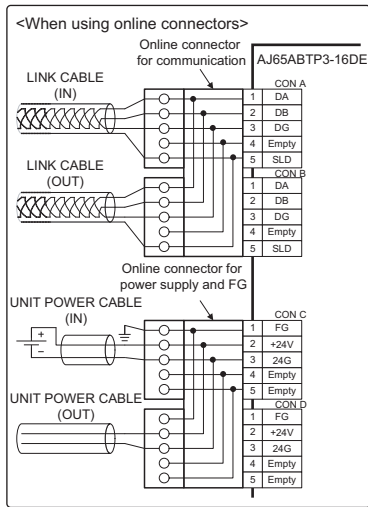
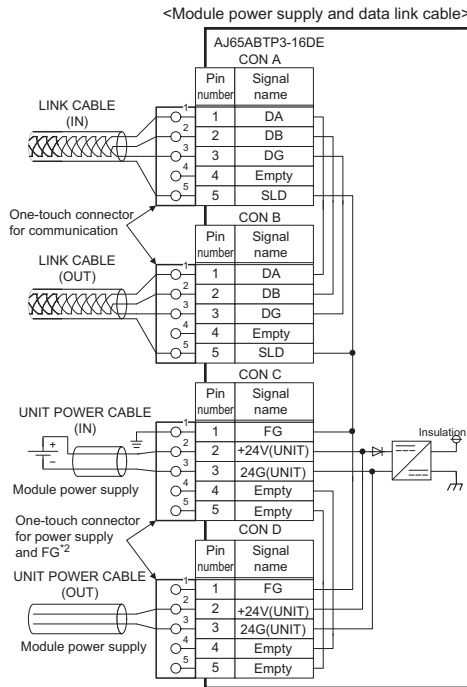

- *1 Insert only one wire into the pin of the spring clamp terminal block. Inserting two or more wires may result in a poor contact to the terminal.
- *2 Attach an unwired connector plug to an unused one-touch connector for power supply and FG.

External connection

■ Signal array of connector

Pin number	Connector			
	CON A	CON B	CON C	CON D
1	DA		FG	
2	DB		+24V(UNIT)	
3	DG		24G(UNIT)	
4	Empty		Empty	
5	SLD		Empty	

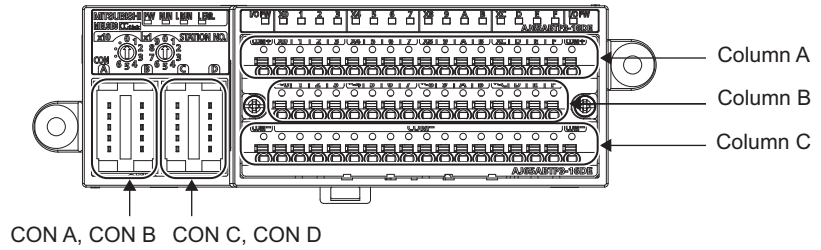

■ Terminal layout of terminal block

Terminal block	Pin number																	
	1	2	3	4	5	6	7	8	9	10	11	12	13	14	15	16	17	18
Column A	COM+ _{*3}	X0	X1	X2	X3	X4	X5	X6	X7	X8	X9	XA	XB	XC	XD	XE	XF	COM+ _{*3}
Column B		+C0	+C1	+C2	+C3	+C4	+C5	+C6	+C7	+C8	+C9	+CA	+CB	+CC	+CD	+CE	+CF	
Column C	COM- _{*3}	COM-	COM-	COM-	COM-	COM-	COM-	COM-	COM-	COM-	COM-	COM-	COM-	COM-	COM-	COM-	COM-	COM- _{*3}

*3 For I/O power supply, use 1A and 1C pins of a spring clamp terminal block for input. For transition wiring of I/O power supply, use the 18A and 18C pins.

4.3 How to Calculate the Current Consumption

When supplying the power to multiple modules in a transition wiring system, configure the system so that the current consumption does not exceed the maximum rated current for the system.

This section shows how to calculate the current consumption using the example of the system shown below.

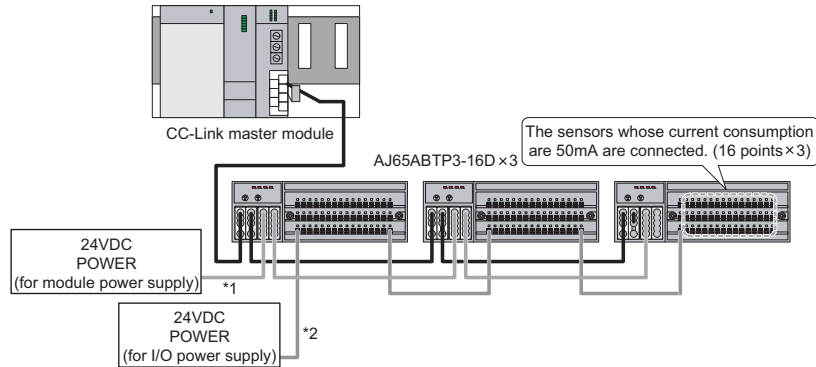

- *1 The current, which flows in the cable connecting the power (for module power supply) and the CC-Link remote I/O module with diagnostic functions, must be 7A or lower.
- *2 The current, which flows in the cable connecting the power (for I/O power supply) and the AJ65ABTP3-16D, must be 8A or lower.
When the power is connected to the AJ65ABTP3-16DE, the current must be 4A or lower.

(1) Current consumption in the system

The table below shows the current consumption of each part in the above system.

Module	Number of the module	Module power supply current	I/O power supply current			
			Input current	Internal circuit current for input part	Externally connected device (sensor)	
					Current consumption	Number of connection points
AJ65ABTP3-16D	3	55mA	6mA	30mA	50mA	16 points

(2) Maximum rated current for the system

- (a) Maximum rated current for the one-touch connector plug for power supply and FG: 7A
- (b) Maximum rated current for the I/O power supply current: 8A (4A when the AJ65ABTP3-16DE is connected)

(3) Calculation of the current consumption at each power port

Conduct the calculation using the current values in (1) and (2), and check whether the current consumption in this system does not exceed the maximum rated current.

(a) Module power supply current

- = (Total of the module power supply current value for the AJ65ABTP3-16D)
- = $55\text{mA} \times 3 = 165\text{mA} < 7\text{A}$ (Maximum rated current for the one-touch connector plug for power supply and FG)

(b) I/O power supply current

$$\begin{aligned} &= (\text{Total current consumption for sensors}) + (\text{Total value of the input current for the AJ65ABTP3-16D}) + (\text{Total value of the internal circuit current for input part of the AJ65ABTP3-16D}) \\ &= 50\text{mA} \times 16 \text{ points} \times 3 + 6\text{mA} \times 16 \text{ points} \times 3 + 30\text{mA} \times 3 \\ &= 2.778\text{A} < 8\text{A} \text{ (Maximum rated current for the I/O power supply current)} \end{aligned}$$

(4) Calculation result

This system can be operated because the module power supply current and the I/O power supply current do not exceed the respective maximum rated currents.

4.4 Function

This chapter describes the functions of the CC-Link remote I/O module with diagnostic functions.

4.4.1 Function list

This section lists the functions of the CC-Link remote I/O module with diagnostic functions.

Item	Description	Reference
Input function	Notifies the remote input (RX) of the ON/OFF status of an input. The remote input (RX) is the buffer memory of the master station on CC-Link.	-
Input diagnostic function	Detects disconnection (no connection) or a short-circuit (ground) of an input wiring (sensor power supply).	Page 37, Section 4.4.2
Sensor power supply disconnection (no connection) detection function	Monitors the current of the common terminal (-Cn/+Cn), which corresponds to the input terminal (Xn), by using a disconnection detection circuit. If the current value becomes 0.3mA or lower, the function regards it as an occurrence of disconnection (no connection).	Page 40, Section 4.4.2 (2)
Sensor power supply short-circuit (ground) detection function	Monitors the current of the common terminal (-Cn/+Cn), which corresponds to the input terminal (Xn), by using a short-circuit detection circuit. If the current value becomes 50mA or higher, the function regards it as an occurrence of a short-circuit (ground).	Page 43, Section 4.4.2 (3)
Detection status hold function	Used to select whether to hold or not to hold the detection status of disconnection (no connection) or a short-circuit (ground) of an input wiring (sensor power supply).	Page 44, Section 4.4.3
Check function of the power supply status of an external power supply	Monitors the power supply status of an external power supply for an input.	Page 46, Section 4.4.4
Transmission speed auto-tracking function	Used to set the transmission speed automatically according to the setting of the master module.	-

4.4.2 Input diagnostic function

This function is to detect disconnection (no connection) or a short-circuit (ground) of an input wiring (sensor power supply).

The occurrence or no occurrence of disconnection (no connection) or a short-circuit (ground) is indicated with the LED on the module.

Also, the occurrence of disconnection (no connection) or a short-circuit (ground) is notified to the CPU module by Disconnection detection status (RWrn + 2H) or Short-circuit detection status (RWrn + 3H).

Overview of input diagnostic functions

● Disconnection (no connection) and short-circuit (ground) detection

- When the current value of common terminal (-Cn/+Cn) is 0.3mA or lower, it is regarded as an occurrence of disconnection (no connection).
- When the current value of common terminal (-Cn/+Cn) is 50mA or higher, it is regarded as an occurrence of short-circuit (ground).

<With the setting to hold the detection status>

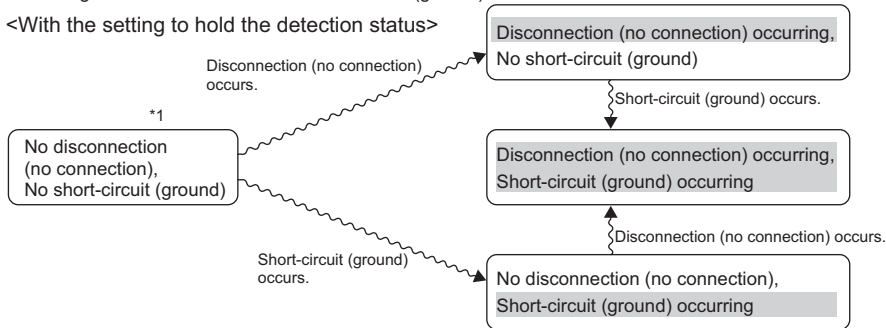

<With the setting not to hold the detection status>

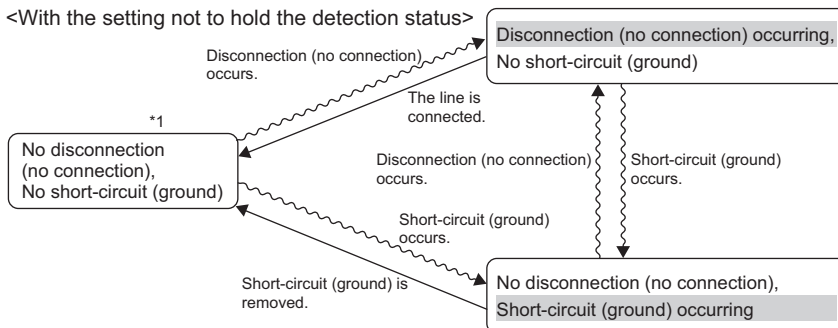

*1 Set "Detect disconnection (1)" to Disconnection detection enable/disable setting (RWwm + 0H).

● Input error indication (Xn LED indication)

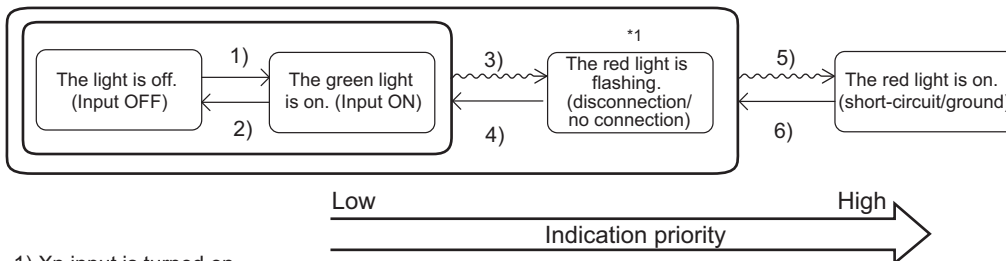

- 1) Xn input is turned on.
- 2) Xn input is turned off.
- 3) The disconnection (no connection) occurs, or "Flash the LED regularly (1)" is set to Disconnection indication command (RWwm + 2H).
- 4) The line is connected, and "Do not flash the LED (0)" is set to Disconnection indication command (RWwm + 2H).
- 5) The short-circuit (ground) occurs, or "Turn on the LED (1)" is set to Short-circuit indication command (RWwm + 3H).
- 6) The short-circuit (ground) is removed, and "Do not turn on the LED (0)" is set to Short-circuit indication command (RWwm + 3H).

*1 Set "Detect disconnection (1)" to Disconnection detection enable/disable setting (RWwm + 0H).

(1) The list of the conditions to detect disconnection (no connection) or a short-circuit (ground) of a sensor power supply

The locations where the detection is possible (1) to 9)) and the detection conditions are shown below.

(a) AJ65ABTP3-16D

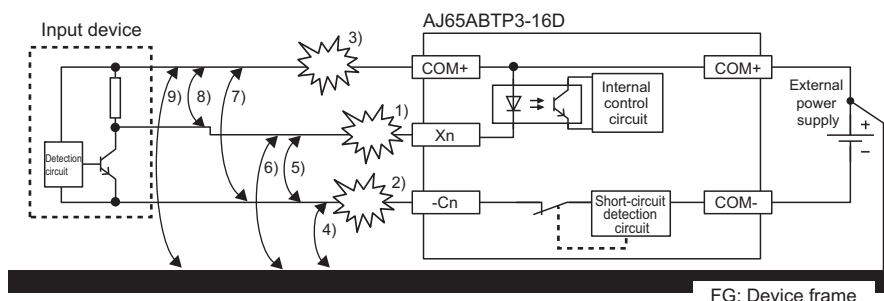

Connected device	Condition	Disconnection (no connection)			Short-circuit (ground)					
		Xn 1)	-Cn 2)	COM+ 3)	-Cn↔FG 4)	Xn↔-Cn 5)	Xn↔FG 6)	-Cn↔COM+ 7)	Xn↔COM+ 8)	COM+↔FG 9)
2-wire input device	Leakage current (higher than 0.3mA)	⊙	⊙	-	○*2	x	○*2*3*4	-	-	-
	Leakage current (0.3mA or lower)	○*1	○*1	-						
3-wire input device	Holding current (higher than 0.3mA)	x	⊙	⊙	○*2	x	○*2*3*4	⊙	○*3*4	x
	Holding current (0.3mA or lower)	x	○*1	○*1						

⊙: Detection is possible, ○: Detection is possible depending on conditions, x: Detection is not possible

- *1 Bleeder resistances must be connected in parallel just proximal to the input device. (Allowable bleeder resistance: 56kΩ)
- *2 The positive common (COM+) of the external power supply must be connected to the device frame.
- *3 The detection is possible when the connected input device is turned on.
- *4 For some input devices, the short-circuit cannot be detected because the short-circuit current does not flow due to the short-circuit protection function.

Point

If a short-circuit occurs, remove the cause immediately. If the short-circuit remains, the internal temperature of the module rises, resulting in malfunction or failure.

(b) AJ65ABTP3-16DE

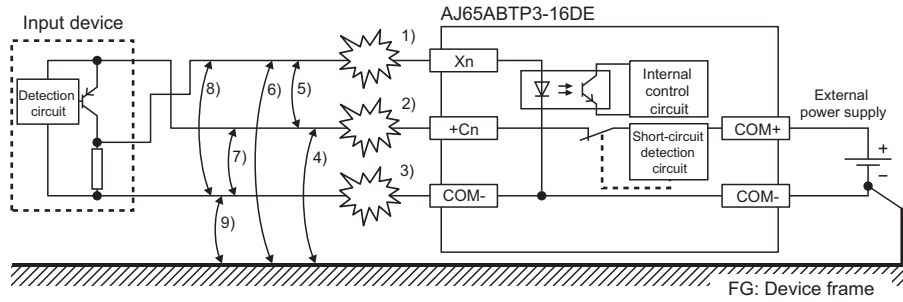

Connected device	Condition	Disconnection (no connection)			Short-circuit (ground)					
		Xn 1)	+Cn 2)	COM- 3)	+Cn↔FG 4)	Xn↔+Cn 5)	Xn↔FG 6)	+Cn↔COM- 7)	Xn↔COM- 8)	COM-↔FG 9)
2-wire input device	Leakage current (higher than 0.3mA)	⊙	⊙	-	○*2	x	○*2*3*4	-	-	-
	Leakage current (0.3mA or lower)	○*1	○*1	-						
3-wire input device	Holding current (higher than 0.3mA)	x	⊙	⊙	○*2	x	○*2*3*4	⊙	○*3*4	x
	Holding current (0.3mA or lower)	x	○*1	○*1						

⊙ : Detection is possible, ○ : Detection is possible depending on conditions, x : Detection is not possible

- *1 Bleeder resistances must be connected in parallel just proximal to the input device. (Allowable bleeder resistance: 56kΩ)
- *2 The negative common (COM-) of the external power supply must be connected to the device frame.
- *3 The detection is possible when the connected input device is turned on.
- *4 For some input devices, the short-circuit cannot be detected because the short-circuit current does not flow due to the short-circuit protection function.

Point!

If a short-circuit occurs, remove the cause immediately. If the short-circuit remains, the internal temperature of the module rises, resulting in malfunction or failure.

(2) Sensor power supply disconnection (no connection) detection function

This function is to monitor the current of the common terminal (-Cn/+Cn), which corresponds to the input terminal (Xn), by using a disconnection detection circuit. If the current value becomes 0.3mA or lower, the function regards it as an occurrence of disconnection (no connection).

(a) How to detect disconnection (no connection)

For each input terminal, set "Detect disconnection (1)" or "Do not detect disconnection (0)" to Disconnection detection enable/disable setting (RWwm + 0H).

The setting is enabled by turning on Initial data setting request flag (RY(n + 1)9).

For an unused input terminal (Xn), set "Do not detect disconnection (0)" to Disconnection detection enable/disable setting (RWwm + 0H).

	b15	b14	b13	b12	b11	b10	b9	b8	b7	b6	b5	b4	b3	b2	b1	b0
Disconnection detection enable/disable setting (RWwm + 0H)	XF	XE	XD	XC	XB	XA	X9	X8	X7	X6	X5	X4	X3	X2	X1	X0

1: Detect disconnection
0: Do not detect disconnection (default)

(b) How to check disconnection (no connection)

The occurrence or no occurrence of disconnection (no connection) can be checked in Disconnection detection status (RWrn + 2H) or with the LED.

- Check by using Disconnection detection status (RWrn + 2H)

Disconnection detection status (RWrn + 2H) indicates the occurrence or no occurrence of disconnection (no connection) of each input terminal.

	b15	b14	b13	b12	b11	b10	b9	b8	b7	b6	b5	b4	b3	b2	b1	b0
Disconnection detection status (RWrn + 2H)	XF	XE	XD	XC	XB	XA	X9	X8	X7	X6	X5	X4	X3	X2	X1	X0

1: Disconnection (no connection) occurring
0: No disconnection (no connection)

- Check with the LED

The red LED is flashing only during the occurrence of the disconnection (no connection).

The LED turns off when the line is connected.

To keep the red LED flashing even after the line is connected, create the sequence program as follows:

- Set "Flash the LED regularly (1)" to Disconnection indication command (RWwm + 2H) while "Disconnection (no connection) occurring (1)" is set to Disconnection detection status (RWrn + 2H).^{*1}

	b15	b14	b13	b12	b11	b10	b9	b8	b7	b6	b5	b4	b3	b2	b1	b0
Disconnection indication command (RWwm + 2H)	XF	XE	XD	XC	XB	XA	X9	X8	X7	X6	X5	X4	X3	X2	X1	X0

1: Flash the LED regularly
0: Do not flash the LED (default)

*1 If "Turn on the LED (1)" is set to Short-circuit indication command (RWwm + 3H) while "Flash the LED regularly (1)" is set to Disconnection indication command (RWwm + 2H), Short-circuit indication command (RWwm + 3H) is prioritized and the red LED turns on.

(c) Holding the detection status of disconnection (no connection)

The indication of Disconnection detection status (RWrn + 2H) changes depending on the setting of Detection status hold command (RWwm + 1H). For details, refer to the "Indication change according to the detection status hold function" section. (Page 44, Section 4.4.3 (2))

(d) False detection of disconnection (no connection) when the input device whose current consumption is 0.3mA or lower is used

Disconnection (no connection) might be mistakenly detected if the current consumption of the input device is 0.3mA or lower when it is connected.

- Not to use the disconnection (no connection) detection function
Set "Do not detect disconnection (0)" to Disconnection detection enable/disable setting (RWwm + 0H).
- To use the disconnection (no connection) detection function (When the AJ65ABTP3-16D is used)
Connect bleeder resistances in parallel just proximal to the input device as shown below. (Allowable bleeder resistance: 56kΩ*1)
 - When a 2-wire sensor is connected: Connect the bleeder resistance between Xn and -Cn as shown below.

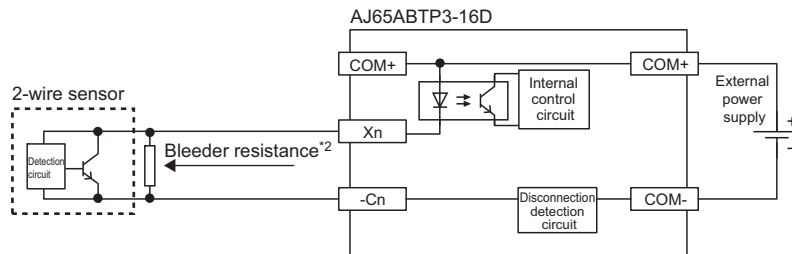

- When a 3-wire sensor is connected: Connect the bleeder resistances between COM+ and -Cn as shown below.

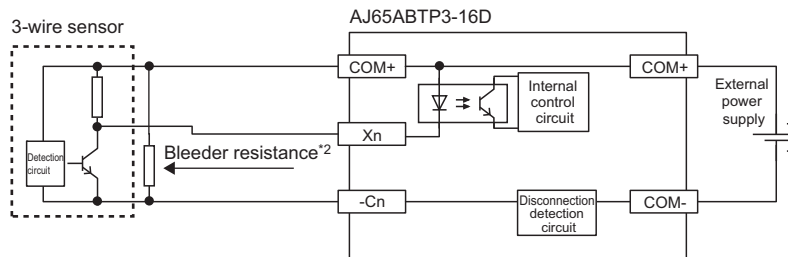

*1 The formula to check the allowable bleeder resistance is shown below.

$$\frac{\text{Input voltage (V)}}{\text{Bleeder resistance (k}\Omega\text{)} \times \text{Tolerance}} > 0.3 \text{ (mA)}$$

$$\frac{20.4 \text{ (V)}}{56 \text{ (k}\Omega\text{)} \times 1.1} = 0.331 \text{ (mA)} > 0.3 \text{ (mA)}$$

As proved with the formula above, by connecting the bleeder resistance of 56kΩ, the current consumption of the input device becomes higher than 0.3mA when it is connected.

*2 Connect the bleeder resistance just proximal to the input device. If not, disconnection (no connection) between the bleeder resistance and the input device cannot be detected.

- To use the disconnection (no connection) detection function (When the AJ65ABTP3-16DE is used) Connect bleeder resistances in parallel just proximal to the input device as shown below. (Allowable bleeder resistance: $56\text{k}\Omega^{*1}$)

- When a 2-wire sensor is connected: Connect the bleeder resistance between Xn and +Cn as shown below.

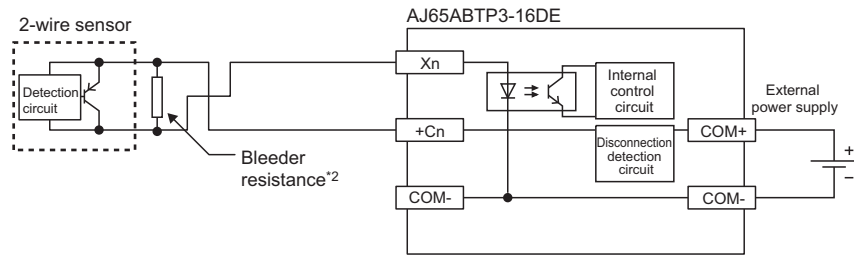

- When a 3-wire sensor is connected: Connect the bleeder resistances between COM- and +Cn as shown below.

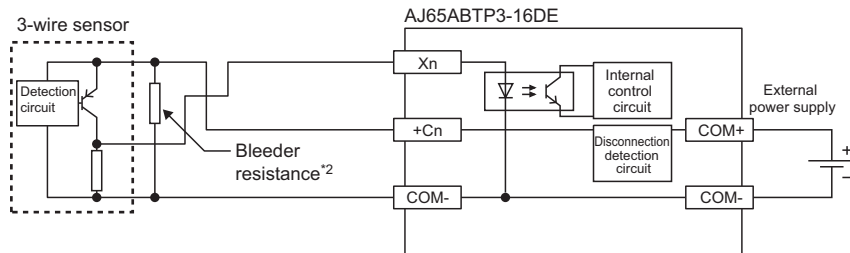

- *1 The formula to check the allowable bleeder resistance is shown below.

$$\frac{\text{Input voltage (V)}}{\text{Bleeder resistance (k}\Omega\text{)} \times \text{Tolerance}} > 0.3 \text{ (mA)}$$

$$\frac{20.4 \text{ (V)}}{56 \text{ (k}\Omega\text{)} \times 1.1} = 0.331 \text{ (mA)} > 0.3 \text{ (mA)}$$

As proved with the formula above, by connecting the bleeder resistance of $56\text{k}\Omega$, the current consumption of the input device becomes higher than 0.3mA when it is connected.

- *2 Connect the bleeder resistance just proximal to the input device. If not, disconnection (no connection) between the bleeder resistance and the input device cannot be detected.

(e) Counting the number of disconnection (no connection) detections

The detection number of disconnection (no connection) of an input wiring (sensor power supply) can be counted by using the sequence program. For details on the sequence program, refer to "PROGRAMMING".

(Page 81, CHAPTER 6)

(3) Sensor power supply short-circuit (ground) detection function

This function is to monitor the current of the common terminal (-Cn/+Cn), which corresponds to the input terminal (Xn), by using a short-circuit detection circuit. If the current value becomes 50mA or higher, the function regards it as an occurrence of a short-circuit (ground).

Also, when a short-circuit (ground) occurs, the common terminal (-Cn/+Cn) for the power supply line, which is connected to the input device, is forced to be turned off in units of contact.

When the short-circuit is removed, the I/O control is automatically restored, and the common terminal (-Cn/+Cn) is turned on.

(a) How to detect a short-circuit (ground)

The occurrence or no occurrence of a short-circuit (ground) can be checked in Short-circuit detection status (RWrn + 3H) or with the LED.

The setting by a user is not required.

(b) How to check a short-circuit (ground)

The occurrence or no occurrence of a short-circuit (ground) can be checked in Short-circuit detection status (RWrn + 3H) or with the LED.

- Check by using Short-circuit detection status (RWrn + 3H)

Short-circuit detection status (RWrn + 3H) indicates the occurrence or no occurrence of a short-circuit (ground) of each input terminal.

	b15	b14	b13	b12	b11	b10	b9	b8	b7	b6	b5	b4	b3	b2	b1	b0
Short-circuit detection status (RWrn + 3H)	XF	XE	XD	XC	XB	XA	X9	X8	X7	X6	X5	X4	X3	X2	X1	X0

1: Short-circuit (ground) occurring
0: No short-circuit (ground)

- Check with the LED

The red LED is on only during the occurrence of a short-circuit (ground).

The LED turns off when the short-circuit (ground) is removed.

To keep the red LED on even after the short-circuit (ground) is removed, create the sequence program as follows:

- Set "Turn on the LED (1)" to Short-circuit indication command (RWwm + 3H) while "Short-circuit (ground) occurring (1)" is set to Short-circuit detection status (RWrn + 3H).^{*1}

	b15	b14	b13	b12	b11	b10	b9	b8	b7	b6	b5	b4	b3	b2	b1	b0
Short-circuit indication command (RWwm + 3H)	XF	XE	XD	XC	XB	XA	X9	X8	X7	X6	X5	X4	X3	X2	X1	X0

1: Turn on the LED
0: Do not turn on the LED (default)

*1 If "Turn on the LED (1)" is set to Short-circuit indication command (RWwm + 3H) while "Flash the LED regularly (1)" is set to Disconnection indication command (RWwm + 2H), Short-circuit indication command (RWwm + 3H) is prioritized and the red LED turns on.

(c) Holding the detection status of a short-circuit (ground)

The indication of Short-circuit detection status (RWrn + 3H) changes depending on the setting of Detection status hold command (RWwm + 1H). For details, refer to the "Indication change according to the detection status hold function" section. (☞ Page 44, Section 4.4.3 (2))

(d) Precautions for ground detection

To detect a ground occurring between the input terminal (Xn) and the device frame, or between the common terminal (-Cn/+Cn) and the device frame, connect the common (COM+/COM-) of the external power supply to the device frame.

4.4.3 Detection status hold function

This function is used to select whether to hold or not to hold the detection status of disconnection (no connection) or a short-circuit (ground) of an input wiring (sensor power supply).

The function enables the CC-Link remote I/O module with diagnostic functions to keep reporting a temporary occurrence of disconnection (no connection) or a short-circuit (ground).

With the setting not to hold the detection status, the temporary occurrence of disconnection (no connection) or a short-circuit (ground) might not be notified to the master module depending on the link scan timing.

To keep the LED indication, set Disconnection indication command ($RW_{wm} + 2_H$) and Short-circuit indication command ($RW_{wm} + 3_H$).

(1) How to set the detection status hold function

By setting "Hold the detection status (0)" or "Do not hold the detection status (1)" to Detection status hold command ($RW_{wm} + 1_H$), select whether to hold the value in Disconnection detection status ($RW_{rn} + 2_H$) and Short-circuit detection status ($RW_{rn} + 3_H$) for each input terminal.

	b15	b14	b13	b12	b11	b10	b9	b8	b7	b6	b5	b4	b3	b2	b1	b0
Detection status hold command ($RW_{wm} + 1_H$)	XF	XE	XD	XC	XB	XA	X9	X8	X7	X6	X5	X4	X3	X2	X1	X0

1: Do not hold the detection status
0: Hold the detection status (default)

(2) Indication change according to the detection status hold function

- If "Hold the detection status (0)" is set, "Disconnection (no connection) occurring (1)" and "Short-circuit (ground) occurring (1)" remain in Disconnection detection status ($RW_{rn} + 2_H$) and Short-circuit detection status ($RW_{rn} + 3_H$) respectively even after the error causes are removed.
- If "Do not hold the detection status (1)" is set, "Disconnection (no connection) occurring (1)" and "Short-circuit (ground) occurring (1)" are stored in Disconnection detection status ($RW_{rn} + 2_H$) and Short-circuit detection status ($RW_{rn} + 3_H$) only during the occurrence of the errors.
After the error causes are removed, "No disconnection (no connection) (0)" and "No short-circuit (ground) (0)" are stored.
- The values in Disconnection detection status ($RW_{rn} + 2_H$) and Short-circuit detection status ($RW_{rn} + 3_H$) are erased by turning off the power, even though "Hold the detection status (0)" is set to Detection status hold command ($RW_{wm} + 1_H$).

(3) Clearing the detection status when the detection status hold function is used

When the values in Disconnection detection status ($RWr_n + 2_H$) and Short-circuit detection status ($RWr_n + 3_H$) are hold with the detection status hold function, the detection status can be cleared by changing the bit of Detection status hold command ($RWw_m + 1_H$) from "Hold the detection status (0)" to "Do not hold the detection status (1)".

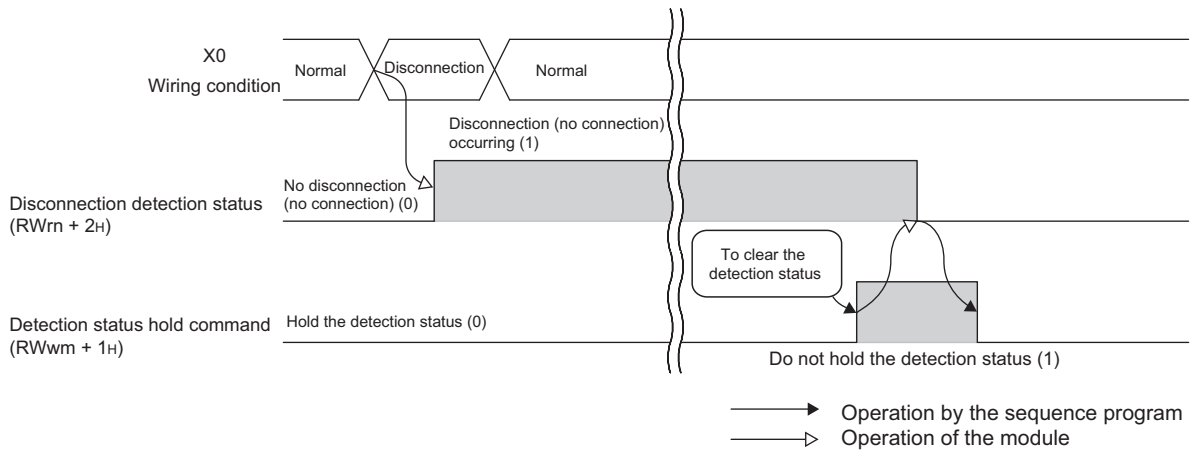

4.4.4 Checking of the power supply status of an external power supply

This section describes how to monitor the power supply status of an external power supply for an input.

(1) Check of the power supply status

(a) Check with SW (link special registers) of the master module

The power supply status is stored in Other station fuse blown status (SW0088 to SW008B) of the master module.

Item	Description																																								
SW0088 to SW008B	<p>The fuse blown status at each station is stored.</p> <table border="1" data-bbox="708 730 1257 965"> <thead> <tr> <th></th> <th>b15</th> <th>b14</th> <th>b13</th> <th>to</th> <th>b2</th> <th>b1</th> <th>b0</th> </tr> </thead> <tbody> <tr> <td>SW0088</td> <td>16</td> <td>15</td> <td>14</td> <td>to</td> <td>3</td> <td>2</td> <td>1</td> </tr> <tr> <td>SW0089</td> <td>32</td> <td>31</td> <td>30</td> <td>to</td> <td>19</td> <td>18</td> <td>17</td> </tr> <tr> <td>SW008A</td> <td>48</td> <td>47</td> <td>46</td> <td>to</td> <td>35</td> <td>34</td> <td>33</td> </tr> <tr> <td>SW008B</td> <td>64</td> <td>63</td> <td>62</td> <td>to</td> <td>51</td> <td>50</td> <td>49</td> </tr> </tbody> </table> <p>0: Normal 1: Error (The external power supply is off.)</p> <p>Numbers 1 to 64 in the above table indicate the station numbers.</p> <ul style="list-style-type: none"> • SW0088 to SW008B are updated independently of SB. • Reserved stations and any station with the number higher than the max. are excepted. 		b15	b14	b13	to	b2	b1	b0	SW0088	16	15	14	to	3	2	1	SW0089	32	31	30	to	19	18	17	SW008A	48	47	46	to	35	34	33	SW008B	64	63	62	to	51	50	49
	b15	b14	b13	to	b2	b1	b0																																		
SW0088	16	15	14	to	3	2	1																																		
SW0089	32	31	30	to	19	18	17																																		
SW008A	48	47	46	to	35	34	33																																		
SW008B	64	63	62	to	51	50	49																																		

(b) Check with the LED

The power supply status can be checked with the I/O PW LED on the CC-Link remote I/O module with diagnostic functions.

- I/O PW LED is on: Supplying power (The module power supply must be on.)
- I/O PW LED is off: Not supplying power
- PART NAMES ( Page 22, CHAPTER 3)

4.5 Remote I/O Signal

This chapter describes the assignments and the functions of the remote I/O signals.

The remote input (RX) means the input signal from the CC-Link remote I/O module with diagnostic functions to the master module. Also, the remote output (RY) means the output signal from the master module to the CC-Link remote I/O module with diagnostic functions. The CC-Link remote I/O module with diagnostic functions uses 32 points for the remote input (RX) and 32 points for the remote output (RY) to communicate with the master station.

4.5.1 List of remote I/O signals

This section lists remote I/O signals.

Signal direction: CC-Link remote I/O module with diagnostic functions to Master module			Signal direction: Master module to CC-Link remote I/O module with diagnostic functions		
Remote input (RX)	Name	Reference	Remote output (RY)	Name	Reference
RXn0	External input signal	Page 49, Section 4.5.2 (1)	RYn0	Use prohibited	-
RXn1					
RXn2					
RXn3					
RXn4					
RXn5					
RXn6					
RXn7					
RXn8					
RXn9					
RXnA					
RXnB					
RXnC					
RXnD					
RXnE					
RXnF					
RX(n + 1)0	Use prohibited	-	RY(n + 1)0		
RX(n + 1)1					
RX(n + 1)2					
RX(n + 1)3					
RX(n + 1)4					
RX(n + 1)5					
RX(n + 1)6					
RX(n + 1)7					
RX(n + 1)8	Initial data processing request flag	Page 49, Section 4.5.2 (2)	RY(n + 1)8	Initial data processing completion flag	Page 52, Section 4.5.2 (5)
RX(n + 1)9	Initial data setting completion flag	Page 51, Section 4.5.2 (3)	RY(n + 1)9	Initial data setting request flag	Page 52, Section 4.5.2 (6)
RX(n + 1)A	Use prohibited	-	RY(n + 1)A	Use prohibited	-
RX(n + 1)B	Remote READY	Page 52, Section 4.5.2 (4)	RY(n + 1)B		
RX(n + 1)C	Use prohibited	-	RY(n + 1)C		
RX(n + 1)D					
RX(n + 1)E					
RX(n + 1)F					

n: the address assigned to the master station by the station number setting



Do not use any "use prohibited" signals as a remote input or output signal. These signals are reserved for system use. If they are used (turned on and off) by users, the performance of the module cannot be guaranteed.

4.5.2 Details of remote I/O signals

This section describes the function of each remote I/O signal of the CC-Link remote I/O module with diagnostic functions.

(1) External input signals (RXn0 to RXnF)

These signals indicate the ON/OFF status of external input signals (X0 to XF).

(2) Initial data processing request flag (RX(n + 1)8)

This flag turns on when the power is turned on. Create the sequence program by using this flag so that the CC-Link remote I/O module with diagnostic functions requests the CPU module to do the initial data setting.

This flag turns off by turning on Initial data processing completion flag (RY(n + 1)8).

(a) Doing the initial data setting when starting up the module

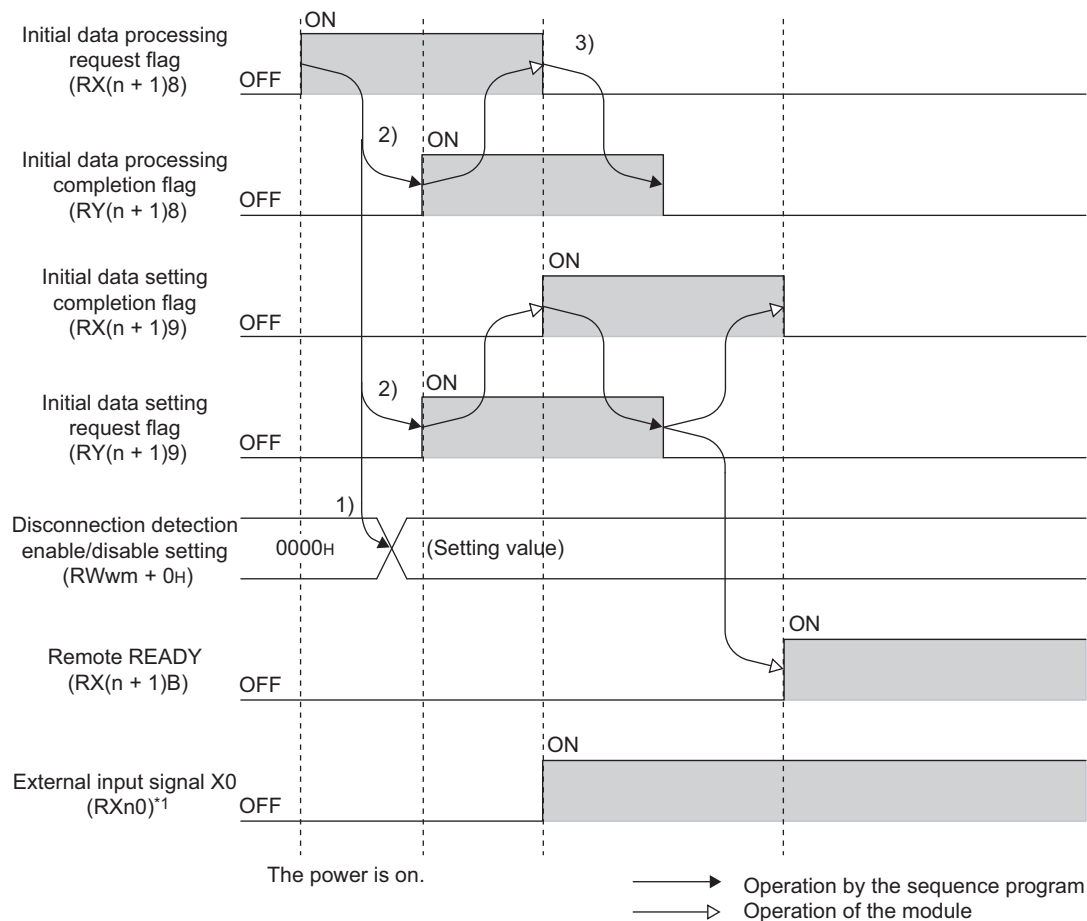

*1 When the sensor connected to X0 is on

- 1) Set the value to Disconnection detection enable/disable setting (RWwm + 0H) when Initial data processing request flag (RX(n + 1)8) is on.
- 2) At the same time, turn on Initial data processing completion flag (RY(n + 1)8) and Initial data setting request flag (RY(n + 1)9).
- 3) External input signals (RXn0 to RXnF) are refreshed when Initial data processing request flag (RX(n + 1)8) turns off.

(b) Doing the initial data setting when the module is operating

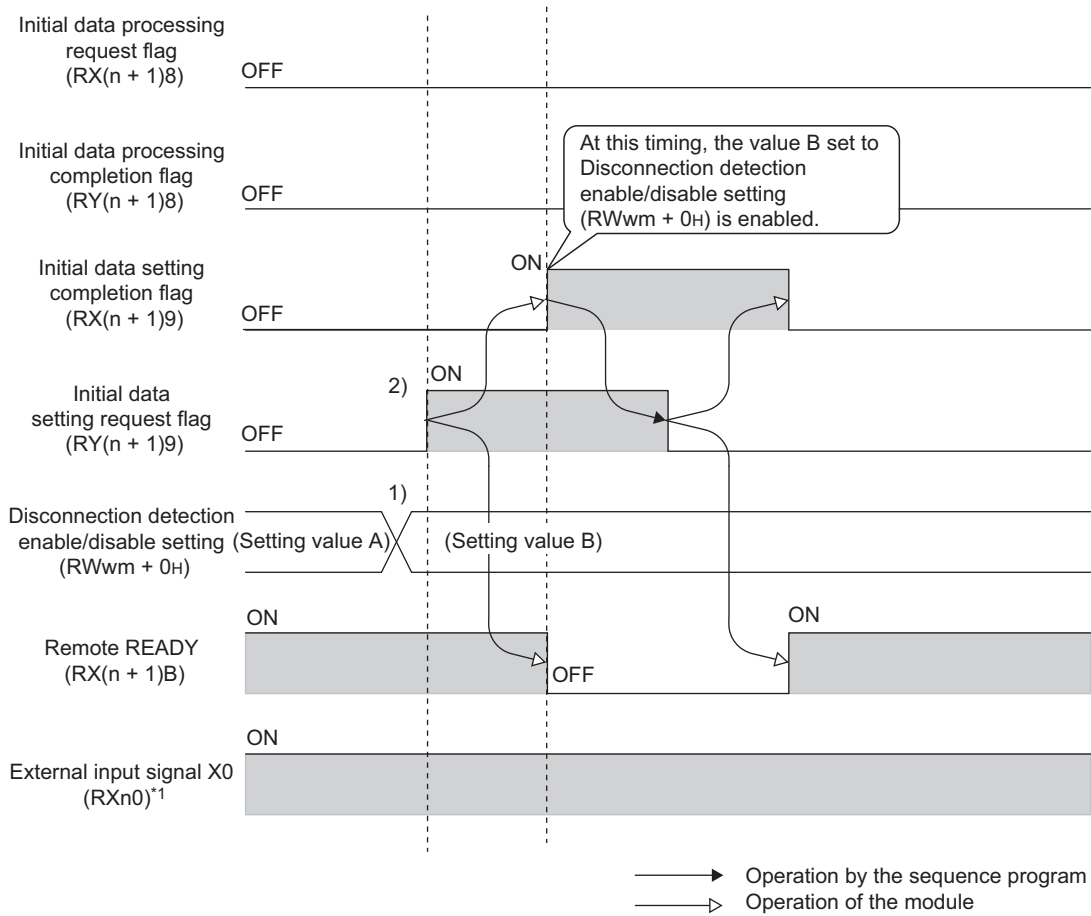

*1 When the sensor connected to X0 is on

- 1) Set the value B to Disconnection detection enable/disable setting (RWwm + 0H).
- 2) Turn on Initial data setting request flag (RY(n + 1)9).

(c) Not doing the initial data setting

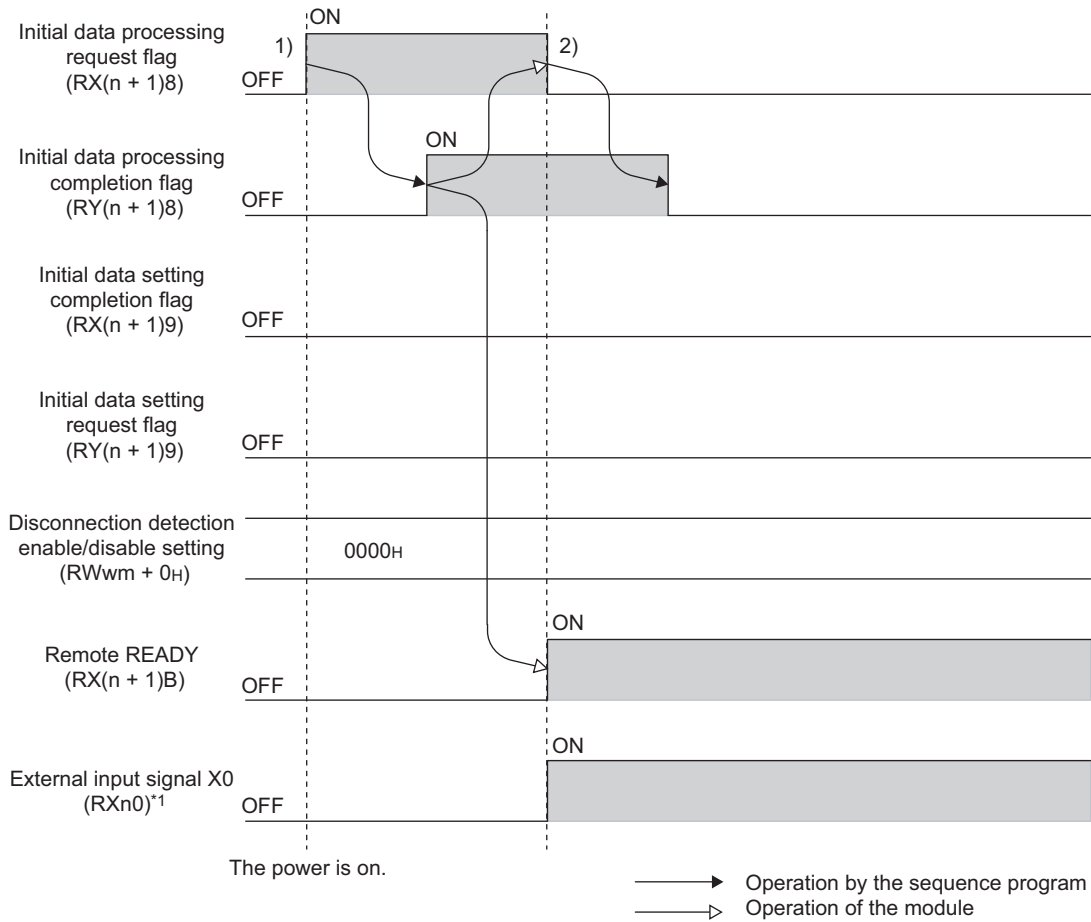

*1 When the sensor connected to X0 is on

- 1) Turn on Initial data processing completion flag (RY(n + 1)8) when Initial data processing request flag (RX(n + 1)8) is on.
- 2) External input signals (RXn0 to RXnF) are refreshed when Initial data processing request flag (RX(n + 1)8) turns off.

(3) Initial data setting completion flag (RX(n + 1)9)

This flag turns on when the initial data setting is completed.

Turn on Initial data setting request flag (RY(n + 1)9) to do the initial data setting.

This flag turns off by turning off Initial data setting request flag (RY(n + 1)9).

For ON/OFF timings of the remote I/O signals for the initial data setting, refer to the "Initial data processing request flag (RX(n + 1)8)" section. (☞ Page 49, Section 4.5.2 (2))

(4) Remote READY (RX(n + 1)B)

This flag is used as an interlock for reading/writing from the master module.

This flag turns on when the initial data processing is completed after the power is supplied.

Turn on Initial data processing completion flag (RY(n + 1)8) to complete the initial data processing.

This flag turns off by turning on Initial data setting request flag (RY(n + 1)9). This flag turns on by turning off Initial data setting request flag (RY(n + 1)9).

For the ON/OFF timing, refer to the "Initial data processing request flag (RX(n + 1)8)" section.

( Page 49, Section 4.5.2 (2))

(5) Initial data processing completion flag (RY(n + 1)8)

When the initial data processing is requested after the power is turned on, do the processing and turn on this flag when it is completed.

For ON/OFF timings of the remote I/O signals for the initial data setting, refer to the "Initial data processing request flag (RX(n + 1)8)" section. ( Page 49, Section 4.5.2 (2))

(6) Initial data setting request flag (RY(n + 1)9)

Turn on this flag at initial data setting.

The following data is subjected to the setting.

- Disconnection detection enable/disable setting (RWwm + 0_H)

For ON/OFF timings of the remote I/O signals for the initial data setting, refer to the "Initial data processing request flag (RX(n + 1)8)" section. ( Page 49, Section 4.5.2 (2))

4.6 Remote Register

This section describes the assignments of the remote registers.

The CC-Link remote I/O module with diagnostic functions has the remote registers for data communication with the master module.

4.6.1 List of remote registers

This section lists remote registers.

Communication direction	Address	Description	Default value	Reference
Master module to CC-Link remote I/O module with diagnostic functions	RWwm + 0 _H	Disconnection detection enable/disable setting	0000 _H	Page 54, Section 4.6.2 (1)
	RWwm + 1 _H	Detection status hold command	0000 _H	Page 54, Section 4.6.2 (2)
	RWwm + 2 _H	Disconnection indication command	0000 _H	Page 54, Section 4.6.2 (3)
	RWwm + 3 _H	Short-circuit indication command	0000 _H	Page 55, Section 4.6.2 (4)
CC-Link remote I/O module with diagnostic functions to Master module	RWrn + 0 _H	Use prohibited	-	-
	RWrn + 1 _H			
	RWrn + 2 _H	Disconnection detection status	0000 _H	Page 55, Section 4.6.2 (5)
	RWrn + 3 _H	Short-circuit detection status	0000 _H	Page 55, Section 4.6.2 (6)

m, n: the address assigned to the master station by the station number setting

Point

Do not write any data to the "use prohibited" of the remote register. If the data are written to the "use prohibited", correct operation of the module cannot be guaranteed.

4.6.2 Details of remote registers

(1) Disconnection detection enable/disable setting (RWwm + 0H)

For each input terminal, set "Detect disconnection (1)" or "Do not detect disconnection (0)" to Disconnection detection enable/disable setting (RWwm + 0H).

The setting is enabled by turning on Initial data setting request flag (RY(n + 1)9).

	b15	b14	b13	b12	b11	b10	b9	b8	b7	b6	b5	b4	b3	b2	b1	b0
Disconnection detection enable/disable setting (RWwm + 0H)	XF	XE	XD	XC	XB	XA	X9	X8	X7	X6	X5	X4	X3	X2	X1	X0

1: Detect disconnection
0: Do not detect disconnection (default)

(2) Detection status hold command (RWwm + 1H)

By setting "Hold the detection status (0)" or "Do not hold the detection status (1)" to Detection status hold command (RWwm + 1H), select whether to hold the value in Disconnection detection status (RWrn + 2H) and Short-circuit detection status (RWrn + 3H) for each input terminal.

If "Hold the detection status (0)" is set, "Disconnection (no connection) occurring (1)" and "Short-circuit (ground) occurring (1)" remain in Disconnection detection status (RWrn + 2H) and Short-circuit detection status (RWrn + 3H) respectively even after the error causes are removed.

	b15	b14	b13	b12	b11	b10	b9	b8	b7	b6	b5	b4	b3	b2	b1	b0
Detection status hold command (RWwm + 1H)	XF	XE	XD	XC	XB	XA	X9	X8	X7	X6	X5	X4	X3	X2	X1	X0

1: Do not hold the detection status
0: Hold the detection status (default)

(3) Disconnection indication command (RWwm + 2H)

The red LED, which indicates the abnormal status of external input signals (X0 to XF), can be forced to be flashing with Disconnection indication command (RWwm + 2H).

By using this remote register, keeping indicating the detection of disconnection (no connection) with the LED is possible even after the error cause is removed.

For details, refer to the "How to check disconnection (no connection)" section. ( Page 40, Section 4.4.2 (2) (b))

	b15	b14	b13	b12	b11	b10	b9	b8	b7	b6	b5	b4	b3	b2	b1	b0
Disconnection indication command (RWwm + 2H)	XF	XE	XD	XC	XB	XA	X9	X8	X7	X6	X5	X4	X3	X2	X1	X0

1: Flash the LED regularly
0: Do not flash the LED (default)

(4) Short-circuit indication command (RWwm + 3H)

The red LED, which indicates the abnormal status of external input signals (X0 to XF), can be forced to be on with Short-circuit indication command (RWwm + 3H).

By using this remote register, keeping indicating the detection of a short-circuit (ground) with the LED is possible even after the error cause is removed.

For details, refer to the "How to check a short-circuit (ground)" section. (☞ Page 43, Section 4.4.2 (3) (b))

	b15	b14	b13	b12	b11	b10	b9	b8	b7	b6	b5	b4	b3	b2	b1	b0
Short-circuit indication command (RWwm + 3H)	XF	XE	XD	XC	XB	XA	X9	X8	X7	X6	X5	X4	X3	X2	X1	X0

1: Turn on the LED
0: Do not turn on the LED (default)

(5) Disconnection detection status (RWrn + 2H)

Disconnection detection status (RWrn + 2H) indicates the occurrence or no occurrence of disconnection (no connection) of each input terminal.

If "Hold the detection status (0)" is set to Detection status hold command (RWwm + 1H), "Disconnection (no connection) occurring (1)" remains in Disconnection detection status (RWrn + 2H) even after the error cause is removed.

	b15	b14	b13	b12	b11	b10	b9	b8	b7	b6	b5	b4	b3	b2	b1	b0
Disconnection detection status (RWrn + 2H)	XF	XE	XD	XC	XB	XA	X9	X8	X7	X6	X5	X4	X3	X2	X1	X0

1: Disconnection (no connection) occurring
0: No disconnection (no connection)

(6) Short-circuit detection status (RWrn + 3H)

Short-circuit detection status (RWrn + 3H) indicates the occurrence or no occurrence of a short-circuit (ground) of each input terminal.

If "Hold the detection status (0)" is set to Detection status hold command (RWwm + 1H), "Short-circuit (ground) occurring (1)" remains in Short-circuit detection status (RWrn + 3H) even after the error cause is removed.

	b15	b14	b13	b12	b11	b10	b9	b8	b7	b6	b5	b4	b3	b2	b1	b0
Short-circuit detection status (RWrn + 3H)	XF	XE	XD	XC	XB	XA	X9	X8	X7	X6	X5	X4	X3	X2	X1	X0

1: Short-circuit (ground) occurring
0: No short-circuit (ground)

CHAPTER 5 PROCEDURES AND SETTINGS BEFORE SYSTEM OPERATION

5.1 Procedures Before Operation

This section describes the procedures required before operating the CC-Link remote I/O module with diagnostic functions.

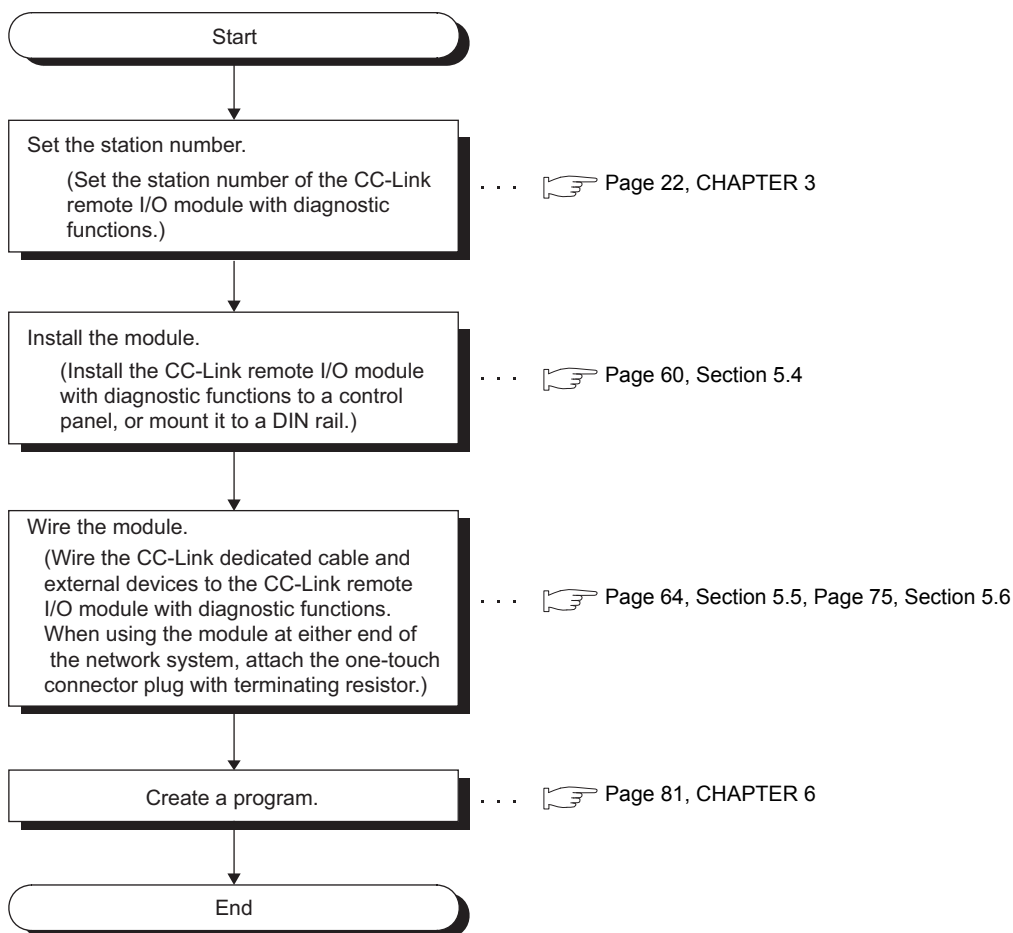

5.2 Handling and Installation Precautions

This section lists the precautions for handling and installing the CC-Link remote I/O module with diagnostic functions.

WARNING

- Do not touch any terminal or connector while power is on. Doing so will cause electric shock.

CAUTION

- Prevent foreign matter such as dust or wire chips from entering the module. Such foreign matter can cause a fire, failure, or malfunction.
- Do not disassemble or modify the modules. Doing so may cause failure, malfunction, injury, or a fire.
- Do not directly touch any conductive part of the module. Doing so can cause malfunction or failure of the module.
- Do not drop or apply strong shock to the module. Doing so may damage the module.
- Tighten the terminal screw within the specified torque range. Undertightening can cause short circuit, fire, or malfunction. Overtightening can damage the screw and/or module, resulting in drop, short circuit, fire, or malfunction.
- When disposing of this product, treat it as industrial waste.
- Use the module in an environment that meets the general specifications in this manual. Failure to do so may result in electric shock, fire, malfunction, or damage to or deterioration of the product.
- Securely fix the module with a DIN rail or mounting screws. Tighten the screws within the specified torque range. Undertightening can cause drop of the screw, short circuit or malfunction. Overtightening can damage the screw and/or module, resulting in drop, short circuit, or malfunction.
- Shut off the external power supply (all phases) used in the system before mounting or removing a module. Failure to do so may cause the module to fail or malfunction.

(1) Tighten the module mounting screws or terminal block screws within the following range. Overtightening can damage the module case.

Screw	Tightening torque range
Mounting bracket (M4)	0.82 to 1.11N·m
2-piece terminal block fixing screw (M3)	0.42 to 0.57N·m

(2) A scratch-resistant film is attached on the surface of the module during transportation.

Remove the film before operation.

(3) Do not install the CC-Link remote I/O module with diagnostic functions to the place where:

- an ambient temperature is outside the range of 0 to 55°C,
- ambient humidity is outside the range of 10 to 90%RH,
- condensation occurs due to a sudden temperature change,
- corrosive gas or combustible gas is present,
- conductive powder (such as dust and iron powder), oil mist, salinity, or organic solvent is filled,
- the module is exposed to direct sunlight,
- a strong electric field or strong magnetic field is generated, and
- the module is subject to vibration or shock.

(4) When installing the CC-Link remote I/O module with diagnostic functions into a control panel, provide clearance of 60mm or more between the top and bottom of the module and other structures or parts so that good ventilation is secured and the module is easily replaced.

(5) Install a CC-Link remote I/O module with diagnostic functions on a level surface.

If the surface is uneven, unnecessary force is applied to the printed circuit board, causing malfunction.

5.3 Station Number

Buffer memory addresses of the master module, where remote I/O signals and read/write data are stored, are determined by setting station numbers to each CC-Link remote I/O module with diagnostic functions. Because the station number that was set is enabled by turning on the power of the module, set station numbers while the power is off. For details, refer to the user's manual for the master module used.

5.4 Module Installation

5.4.1 Installation orientation of the module

The CC-Link remote I/O module with diagnostic functions can be installed in six orientations.

The module can be installed using mounting brackets and module mounting screws. The module can also be installed using a DIN rail.

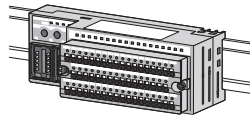

Horizontal installation

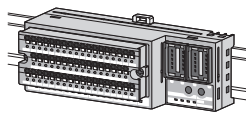

Horizontal installation (reverse)

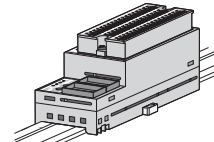

Upward installation

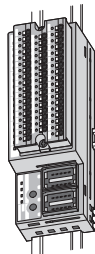

Vertical installation (reverse)

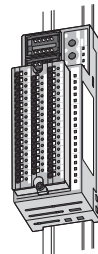

Vertical installation

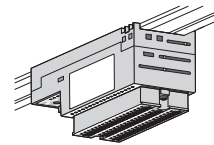

Downward installation

5.4.2 Installation using a DIN rail

This section describes the procedures for installing the CC-Link remote I/O module with diagnostic functions to a control panel using a DIN rail.

(1) Observe the following points when using a DIN rail.

(a) Applicable DIN rail (compliant with IEC 60715)

- TH35-7.5Fe
- TH35-7.5Al

(b) Mounting pitch

When installing a DIN rail to a control panel, keep mounting pitches 200mm or less.

(2) When mounting the module to a DIN rail, hold the center of the module, press it to the DIN rail until it clicks.

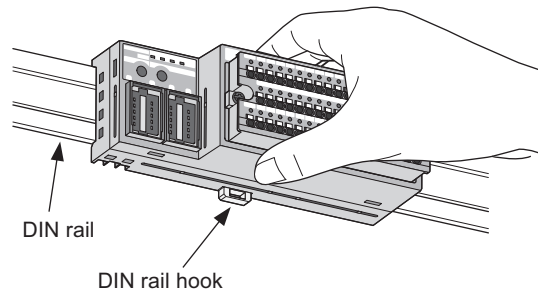

5.4.3 Installation using screws

This section describes the procedures for directly installing the CC-Link remote I/O module with diagnostic functions to a control panel using mounting brackets and screws. If the module is not fixed securely, it may drop.

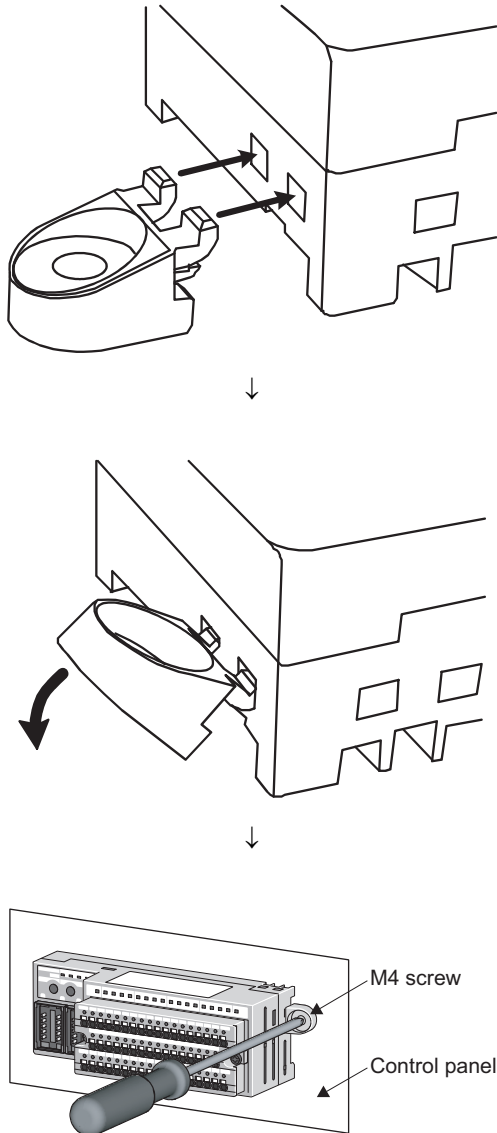

1. Align the projections of a mounting bracket with the corresponding slots of the module.

2. With the mounting bracket obliquely upward, insert its projections to the slots, and press down in the direction of the arrow until they click into place.

**3. Screw the mounting bracket to a control panel.
(Tightening torque range: 0.82 to 1.11N·m)**

5.4.4 Precautions for attaching mounting brackets

Mounting brackets can be attached to the module in three different ways.
 Wrong combination may cause drop of the module.

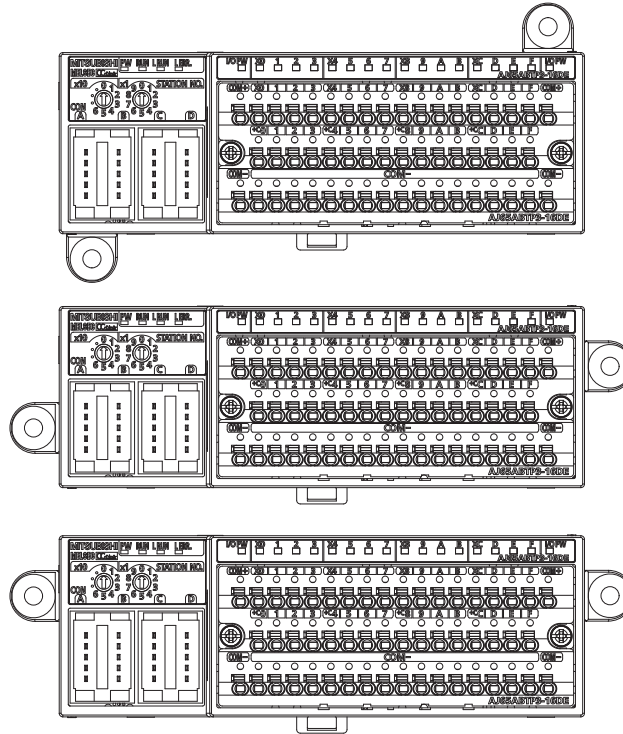

5

5-4 Module Installation
 5.4.4 Precautions for attaching mounting brackets

5.5 Wiring to the Module Power Supply and Data Link Cables

This section describes module power supplies for the master module and the CC-Link remote I/O module with diagnostic functions, and connection between modules using CC-Link dedicated cables.

5.5.1 Wiring precautions

WARNING

- Shut off the external power supply (all phases) used in the system before wiring. Failure to do so may result in electric shock or damage to the product.

CAUTION

- Do not install the control lines or communication cables together with the main circuit lines or power cables. Keep a distance of 100mm or more between them. Failure to do so may result in malfunction due to noise.
- Individually ground the FG terminal of the programmable controller with a ground resistance of 100Ω or less. Failure to do so may result in electric shock or malfunction.
- Check the rated voltage and terminal layout before wiring to the module, and connect the cables correctly. Connecting a power supply with a different voltage rating or incorrect wiring may cause a fire or failure.
- Securely connect the cable connectors. Poor contact may cause malfunction.
- Place the cables in a duct or clamp them. If not, dangling cable may swing or inadvertently be pulled, resulting in damage to the module or cables or malfunction due to poor contact.
- Attach an unwired connector plug to an unused one-touch connector for power supply and FG. Failure to do so may cause failure or malfunction.
- Do not install the control lines together with the communication cables, or bring them close to each other. Failure to do so may result in malfunction due to noise.
- Do not pull the cable part by hand when removing a communication cable and power supply cable from a module. For a cable with connector, remove it while holding the connector by hand. Pulling a cable with connected to the module may damage the module or cable, or result in malfunction due to cable poor connection.

5.5.2 Connection using CC-Link dedicated cables

This section shows how to connect the CC-Link remote I/O module with diagnostic functions to the master module.

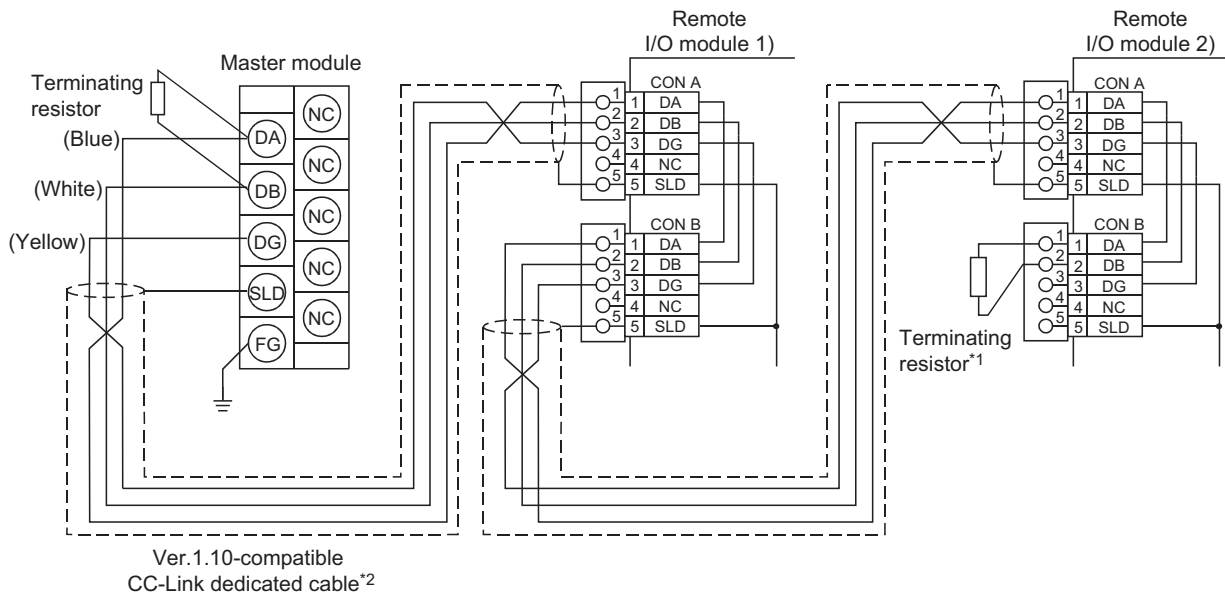

Simplified diagram

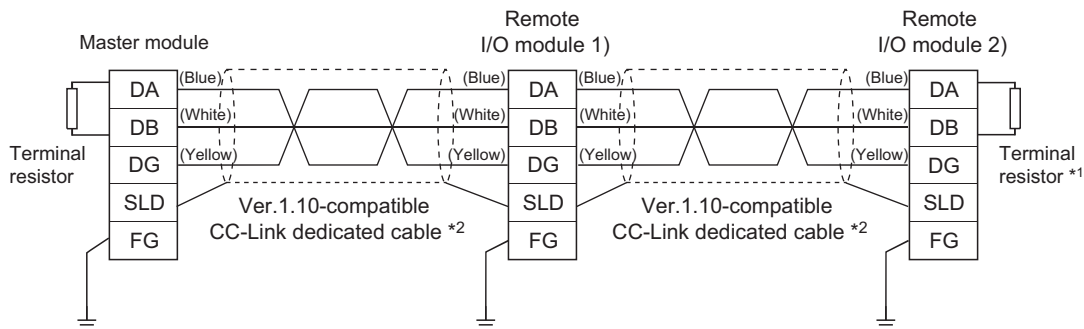



*1 When the CC-Link remote I/O module with diagnostic functions is used as a terminal station, connect an optional one-touch connector plug with terminating resistor (A6CON-TR11(N)).

*2 Use CC-Link dedicated cables in the CC-Link system. Performance of the CC-Link system cannot be guaranteed if any cables other than the CC-Link dedicated cables are used.

For the specifications and any inquiries on the CC-Link dedicated cables, refer to the following:
 CC-Link Partner Association: www.cc-link.org

5.5.3 Connection to the module power supply and data link cables

A one-touch connector is required to connect the CC-Link remote I/O module with diagnostic functions. For handling of one-touch connectors, refer to the following.

- Wiring procedures for the one-touch connector for communication ( Page 69, Section 5.5.5)
- Wiring procedures for the one-touch connector for power supply and FG ( Page 72, Section 5.5.6)

For applicable one-touch connector models, refer to the following.

- List of one-touch connector plugs ( Page 68, Section 5.5.4)

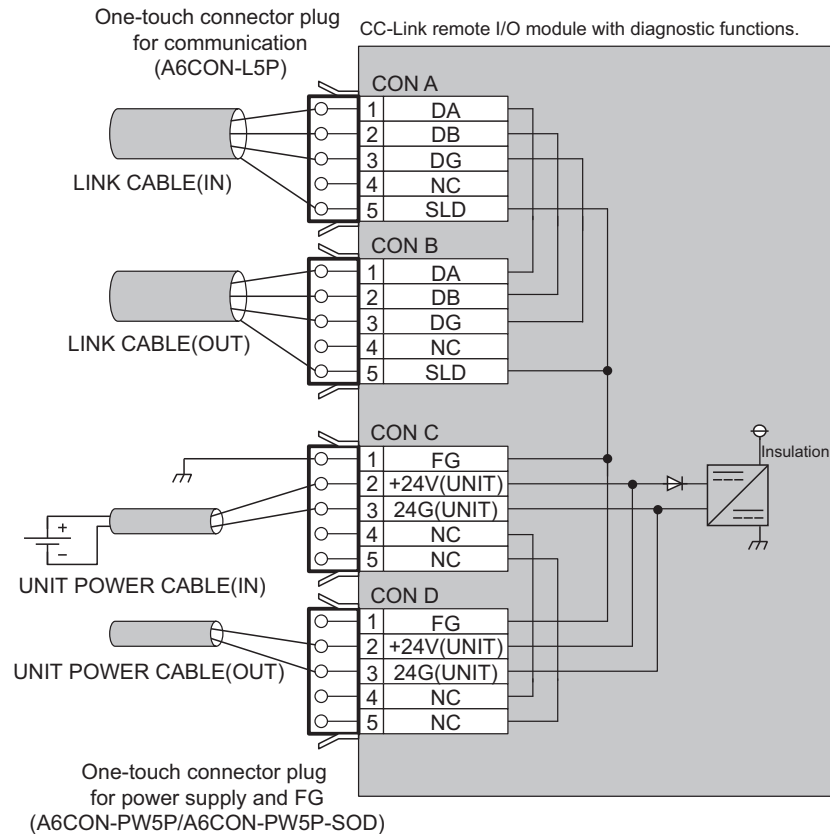

If online module change is desired, connect an optional online connector between the plug and the connector.

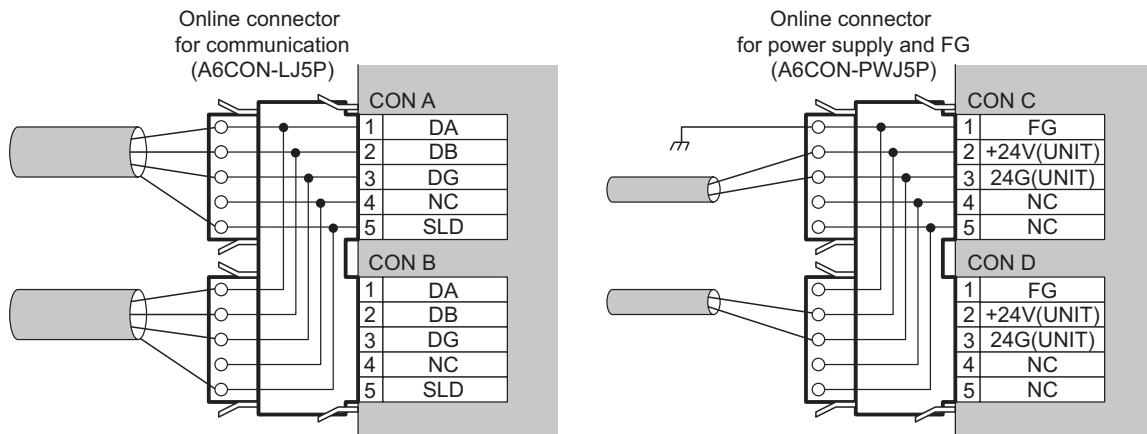

When the module is used at the end of the CC-Link system, attach a one-touch connector plug with terminating resistor (A6CON-TR11(N)) to the module.

When transition wiring is not configured, attach an unwired connector plug to the module for safety and dust prevention.

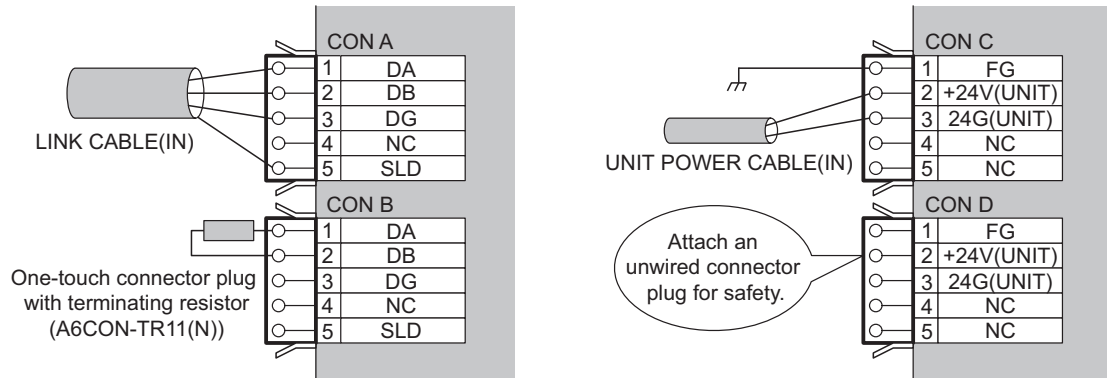

5

5.5 Wiring to the Module Power Supply and Data Link Cables
 5.5.3 Connection to the module power supply and data link cables

5.5.4 List of one-touch connector plugs

The following table lists one-touch connector plugs applicable to the CC-Link remote I/O module with diagnostic functions.

Product name	Mitsubishi model name	Part model name (manufacturer)	Specifications			Color of the cover
			Applicable cable size (core)	Applicable cable size (diameter)	Maximum rated current	
One-touch connector plug for communication *1*3	A6CON-L5P	35505-6000-B0M GF (Sumitomo 3M Limited)	Communication line 0.5mm ² (20 AWG)	φ2.2 to 3.0mm	-	Red
			Shielded cable (drain wire) 0.5mm ² (20 AWG)	-		
One-touch connector plug for power supply and FG *1*2*3	A6CON-PW5P	35505-6080-A00 GF (Sumitomo 3M Limited)	0.75mm ² (0.66 to 0.98mm ²) (18 AWG)	φ2.2 to 3.0mm	7A*5	Gray
	A6CON-PW5P-SOD	35505-6180-A00 GF (Sumitomo 3M Limited)	Wire diameter: 0.16mm or more Insulating coating material: PVC (heat-resistant)	φ2.0 to 2.3mm		Blue
Online connector for communication*4	A6CON-LJ5P	35720-L200-B00 AK (Sumitomo 3M Limited)	-	-	-	-
Online connector for power supply and FG*4	A6CON-PWJ5P	35720-L200-A00 AK (Sumitomo 3M Limited)	-	-	-	-
One-touch connector plug with terminating resistor	A6CON-TR11	-	With terminating resistor (110Ω)			-
	A6CON-TR11N		With terminating resistor (110Ω) (built-in type)			

*1 The A6CON-□5P (manufactured by Mitsubishi) is available in packs of 10 pieces.

*2 One-touch connector plugs can no longer be used once crimped.

*3 Check the outside diameter of an applicable cable and select a connector.

*4 The A6CON-□J5P (manufactured by Mitsubishi) is available in packs of 5 pieces.

*5 Keep the current within the allowable range of the connected cable.

5.5.5 Wiring procedures for the one-touch connector for communication

This section describes the wiring procedures for the one-touch connector for communication.

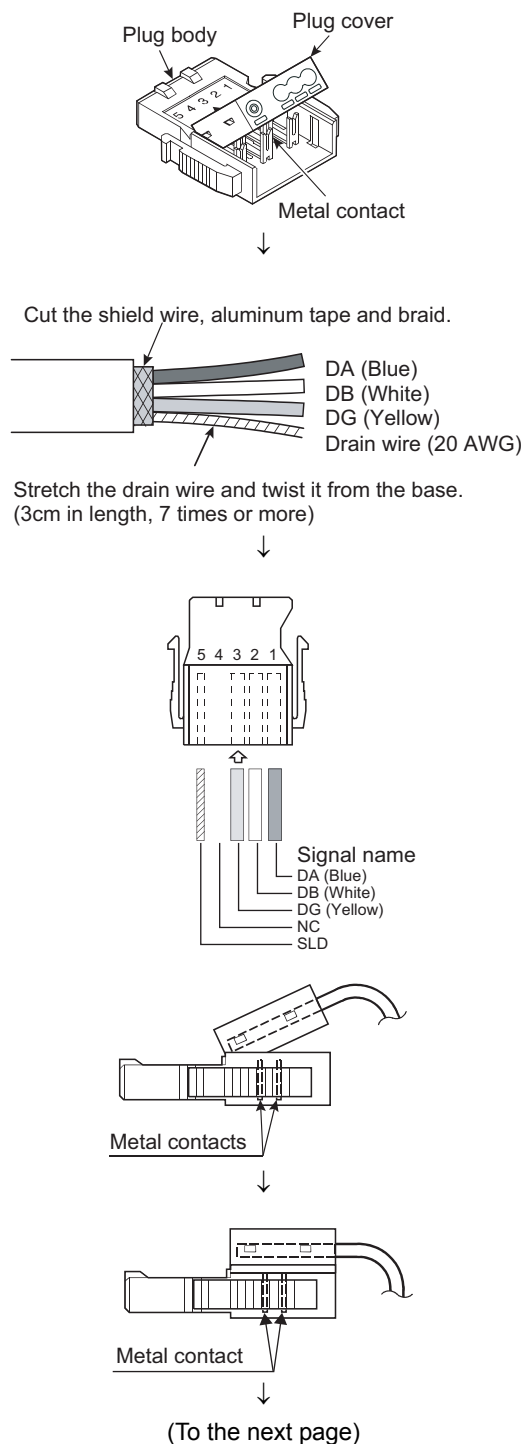

1. Check the connector.

Check that a plug cover is attached to the plug.

Note: Do not press the plug cover firmly into the plug before a cable is inserted.

Once crimped, the plug can no longer be used.

2. Prepare a communication cable for connection.

Strip the cable jacket 3cm or more and perform the processing described on the left.

If the wire lengths are not even, trim their ends with nippers to the same length.

3. Insert a cable.

Lift the end of the plug cover and insert a cable until it reaches the other end of the cover.

Failure to do so may cause an improper crimping.

4. Set the plug cover.

After the cable is inserted, put down the plug cover and set it to the position where the metal contacts fit into the cover.

5

5.5 Wiring to the Module Power Supply and Data Link Cables
5.5.5 Wiring procedures for the one-touch connector for communication

(From the previous page)

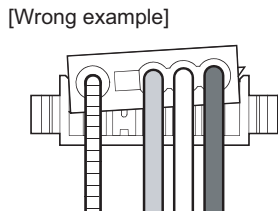
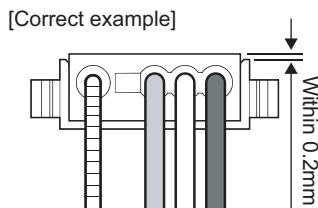
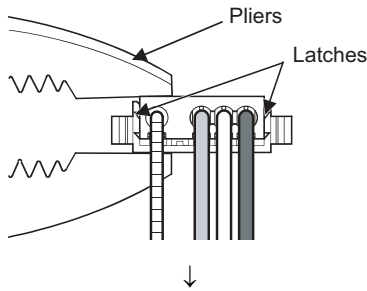
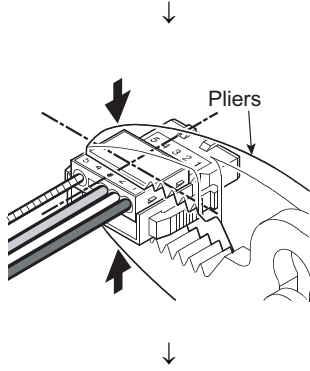

(To the next page)

5. Crimp the plug cover into the plug.

Hold the center of the plug cover with pliers and press it vertically into the plug.

Then, press the latches located at both ends of the plug cover into the plug.

Check that the cover is fixed to the plug with the latches.

6. Check the crimped state from the side.

Check that the plug cover is horizontally-embedded to the plug.

Check also that the floating part of the cover is within 0.2mm.

Note: As shown in the wrong example on the left, if the cover is not horizontally-embedded or the floating part is more than 0.2mm, it may result in improper crimping.

Press the plug cover firmly into the plug with pliers. (Refer to the correct example.)

(From the previous page)



[Correct example]

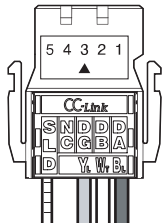

7. Check the crimped state from the top.

Check that there is no clearance between the plug and the cover.

Note: As shown in the wrong example on the left, if the latch is not securely engaged, clearance occurs between the plug and the cover.

Press the plug cover firmly into the plug with pliers. (Refer to the correct example.)

[Wrong example]

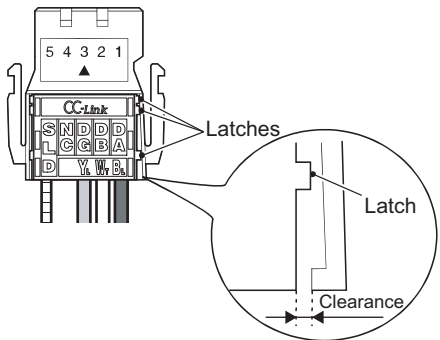

Wiring completed

5.5.6 Wiring procedures for the one-touch connector for power supply and FG

This section describes the wiring procedures for the one-touch connector for power supply and FG.

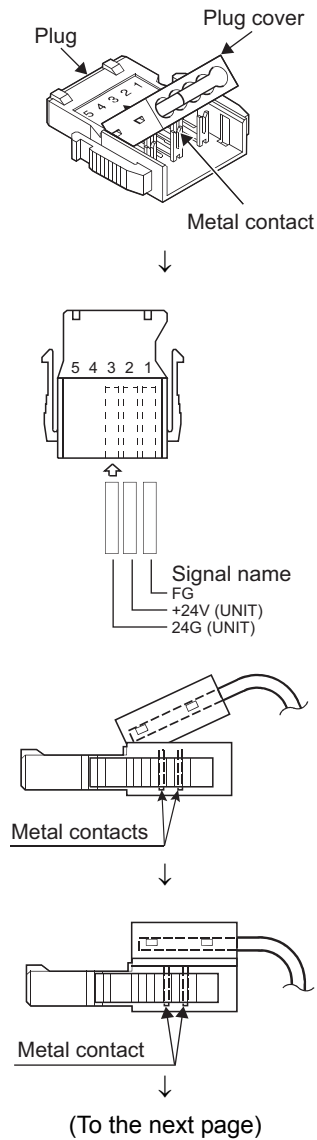

1. Check the connector.

Check that a plug cover is attached to the plug.

Note: Do not press the plug cover firmly into the plug before a cable is inserted.

Once crimped, the plug can no longer be used.

2. Insert a cable.*1

Lift the end of the plug cover and insert a cable until it reaches the other end of the cover.

Failure to do so may cause an improper crimping.

Note: Use cables applicable to the module.

3. Set the plug cover.

After the cable is inserted, put down the plug cover and set it to the position where the metal contacts fit into the cover.

(From the previous page)

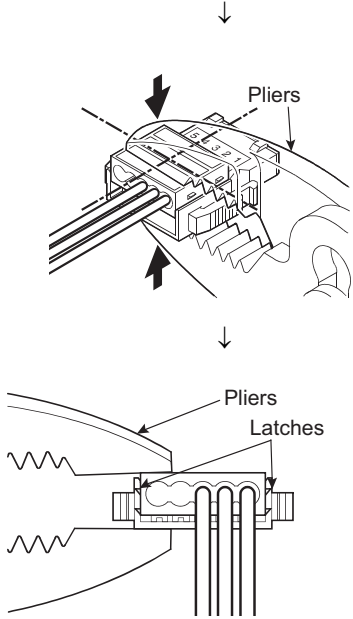

4. Crimp the plug cover into the plug.

Hold the center of the plug cover with pliers and press it vertically into the plug

Then, press the latches located at both ends of the plug cover into the plug. Check that the cover is fixed to the plug with the latches.

[Correct example]

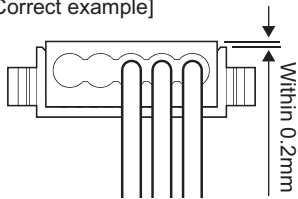

[Wrong example]

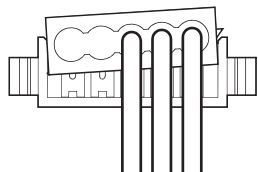

(To the next page)

5. Check the crimped state from the side.

Check that the plug cover is horizontally-embedded to the plug. Check also that the floating part of the cover is within 0.2mm.

Note: As shown in the wrong example on the left, if the cover is not horizontally-embedded or the floating part is more than 0.2mm, it may result in improper crimping. Press the plug cover firmly into the plug with pliers. (Refer to the correct example.)

(From the previous page)



[Correct example]

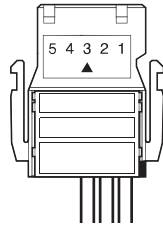

6. Check the crimped state from the top.

Check that there is no clearance between the plug and the cover.

Note: As shown in the wrong example on the left, if the latch is not securely engaged, clearance occurs between the plug and the cover.

Press the plug cover firmly into the plug with pliers. (Refer to the correct example.)

[Wrong example]

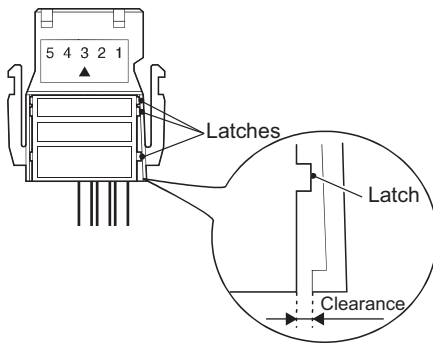

Wiring completed

- *1 When a cabtyre cable is used:
Strip the cable jacket 2cm or more.
If the wire lengths are not even, trim their ends with nippers to the same length.

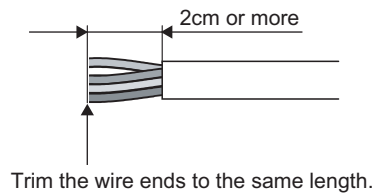

5.6 Wiring to the External Power Supply and Input Signals

(1) Connection of cables

Fully insert a cable, which is inserted to a bar solderless terminal, into the pin of the terminal block. Then, slightly pull the cable to check that it is securely clamped.

(2) Disconnection of cables

Fully press the open/close button where the disconnection-target power cable or input signal cable is connected using a flathead screwdriver.

Disconnect the cable while the open/close button is pressed.

Point

- Use an applicable bar solderless terminal when connecting an external power supply cable or input signal cable to a spring clamp terminal block (push-in type).
If the striped part of the cable is directly inserted to a pin, the cable cannot be clamped securely.
- As for the wire strip length, follow the specifications of the bar solderless terminal used.
Also, use a crimp tool to attach a bar solderless terminal to a cable.
- Check the size of a pin and a bar solderless terminal before connection, and insert the terminal in the correct orientation.
Inserting the terminal whose size is larger than the pin size may damage the terminal block.

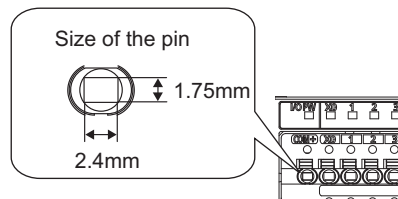

- Use a flathead screwdriver (blade width: 3.5mm or less) to press each open/close button.

(3) External connection example

The following figure shows an external connection example of the CC-Link remote I/O module with diagnostic functions.

(a) AJ65ABTP3-16D

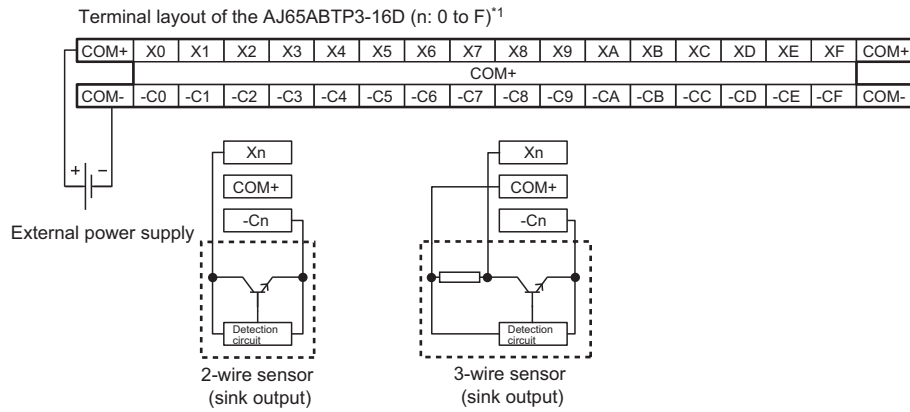

*1 Insert only one wire into the pin of the spring clamp terminal block. Inserting two or more wires may result in a poor contact to the terminal.

Terminal	Description
X0 to XF	Input terminal
COM+	External power supply terminal (24VDC)
COM-	External power supply terminal (0VDC)
-C0 to -CF	Common terminal (negative pole)

(b) AJ65ABTP3-16DE

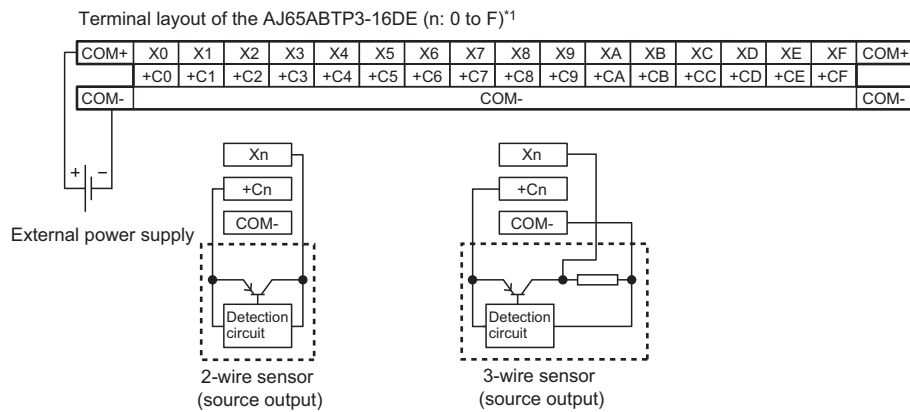

*1 Insert only one wire into the pin of the spring clamp terminal block. Inserting two or more wires may result in a poor contact to the terminal.

Terminal	Description
X0 to XF	Input terminal
COM+	External power supply terminal (24VDC)
COM-	External power supply terminal (0VDC)
+C0 to +CF	Common terminal (positive pole)

5.6.1 Wiring precautions

(1) Precautions for input wiring

To maximize performance of the CC-Link remote I/O module with diagnostic functions and ensure high-reliability of the system, input wiring that is less susceptible to noise is required.

Observe the following wiring precautions.

- Do not install the cables together with the main circuit lines or power cables.
Keep a distance of 100mm or more between them.
- Consider the use of shielded cables if the module is used in an environment that is susceptible to noise.

(2) Restrictions on ground fault detection

(a) AJ65ABTP3-16D

To detect a ground fault, the positive side of the external power supply must be connected to the device frame.

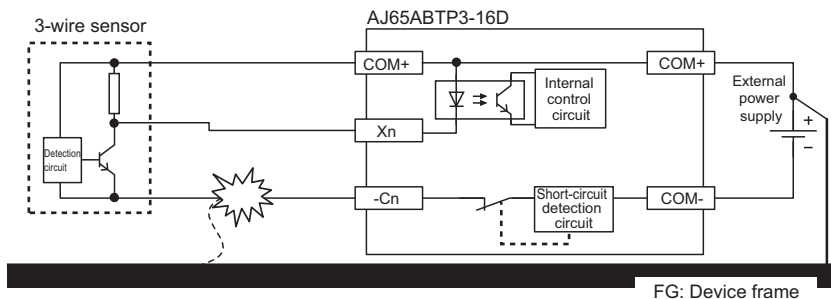

(b) AJ65ABTP3-16DE

To detect a ground fault, the negative side of the external power supply must be connected to the device frame.

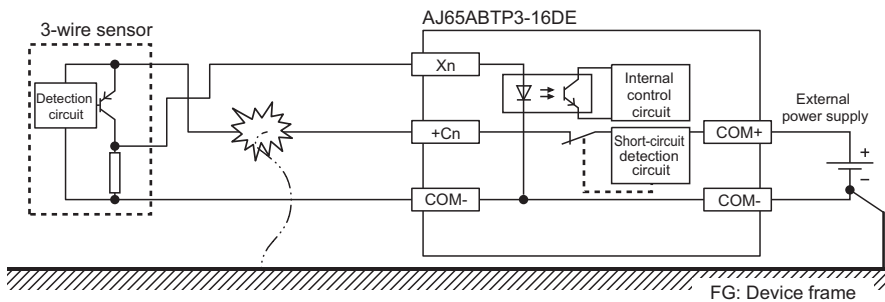

5

5.6 Wiring to the External Power Supply and Input Signals
5.6.1 Wiring precautions

5.6.2 Installation and removal of the spring clamp terminal block (push-in type)

(1) Installation of the spring clamp terminal block (push-in type)

Securely install a terminal block to the module using 2-piece terminal block fixing screws.

Undertightening can cause drop of the screw, short circuit or malfunction. (Tightening torque range: 0.42 to 0.57N•m)

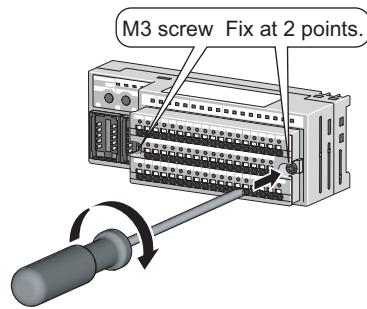

(2) Removal of the spring clamp terminal block (push-in type)

The 2-piece terminal block can be easily removed by loosening the fixing screws, because the terminal block is lifted by doing so.

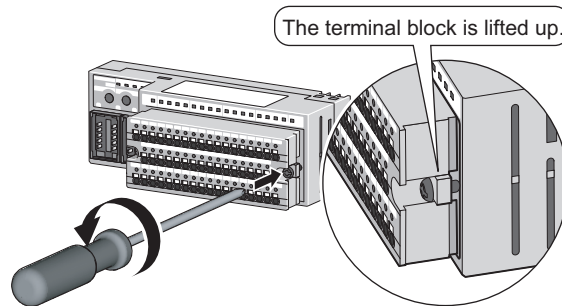

(3) Recommended product list

The following table lists the products related to the spring clamp terminal block.

Product name	Model name	Applicable wire size	Contact
Bar solderless terminal	TE 0.5-8, TE 0.5-10	0.5mm ²	NICHIFU TERMINAL MFG Co., Ltd.
	TE 0.75-8, TE 0.75-10	0.75mm ²	
	TE 1.0-8, TE 1.0-10	0.9 to 1.0mm ²	
	TE 1.5-8, TE 1.5-10	1.25 to 1.5mm ²	
Tool dedicated for bar solderless terminal	NH79	-	
Bar solderless terminal	AI 0.25-12BU	0.25mm ²	PHOENIX CONTACT
	AI 0.34-8TQ, AI 0.34-12TQ	0.34mm ²	
	AI 0.5-8WH, AI 0.5-10WH	0.5mm ²	
	AI 0.75-8GY, AI 0.75-10GY	0.75mm ²	
	AI 1-8RD, AI 1-10RD	1.0mm ²	
	AI 1.5-8BK, AI 1.5-10BK	1.5mm ²	
Tool dedicated for bar solderless terminal	CRIMPFOX6	-	

5.7 Maintenance and Inspection

There is no special inspection item for the CC-Link remote I/O module with diagnostic functions. However, to use the programmable controller system in normal and optimal condition at all times, conduct inspections according to the items listed in the user's manual for the CPU module used.

CHAPTER 6 PROGRAMMING

This chapter describes the programming procedure, basic programs for reading/writing data, and program examples for the CC-Link remote I/O module with diagnostic functions.

When applying the program examples introduced in this chapter to the actual system, ensure the applicability and confirm that it will not cause system control problems.

For the master module, refer to the user's manual for the master module used.

6.1 Programming Procedure

Create a program to detect a disconnection in the CC-Link remote I/O module with diagnostic functions, according to the following procedure.

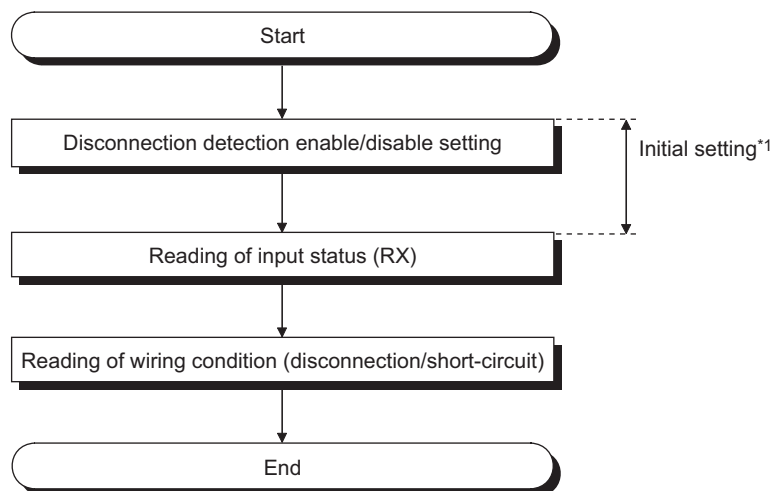

- *1 The setting can be configured using the remote device station initialization procedure registration function when the QCPU (Q mode) or LCPU is used. On the other hand, configure the setting with a sequence program when the ACP, QCPU (A mode), or QnACPU is used.

6.2 Conditions Used for Program Examples

The program examples introduced in this chapter are created under the following conditions.

(1) Use conditions of the CC-Link remote I/O module with diagnostic functions

- Lamp (Y61) turns on/off according to the on/off status of Sensor input (RX0).
- Lamp (Y62) turns on/off according to the disconnection/short-circuit detection status of Sensor input (RX0).
- The number of disconnection detections of Sensor input (RX0) is counted and stored in D device. (This processing is performed on the condition that "Do not hold the detection status (1)" is set to Detection status hold command (RWw1).)

(2) System configuration

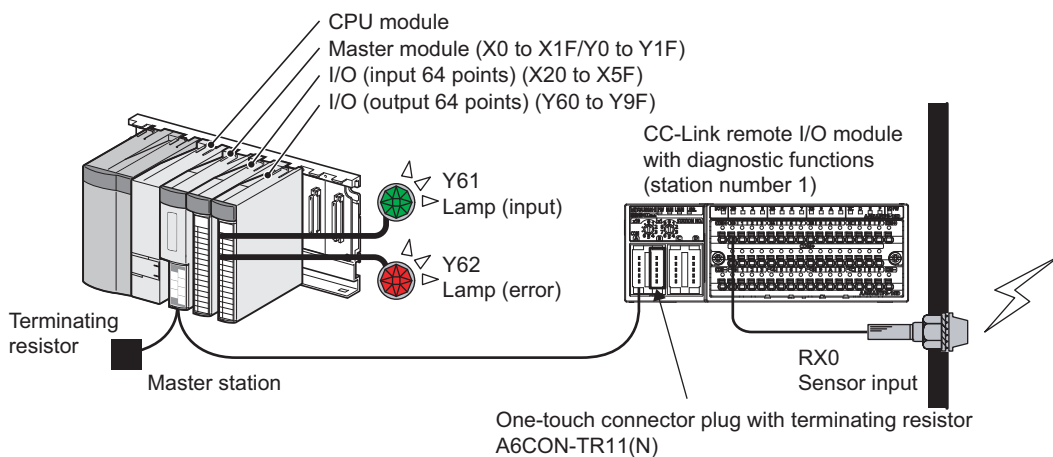

(3) Relationship between remote I/O signals and remote register assignments

(a) For the QCPU (Q mode), LCP, and QnACPU

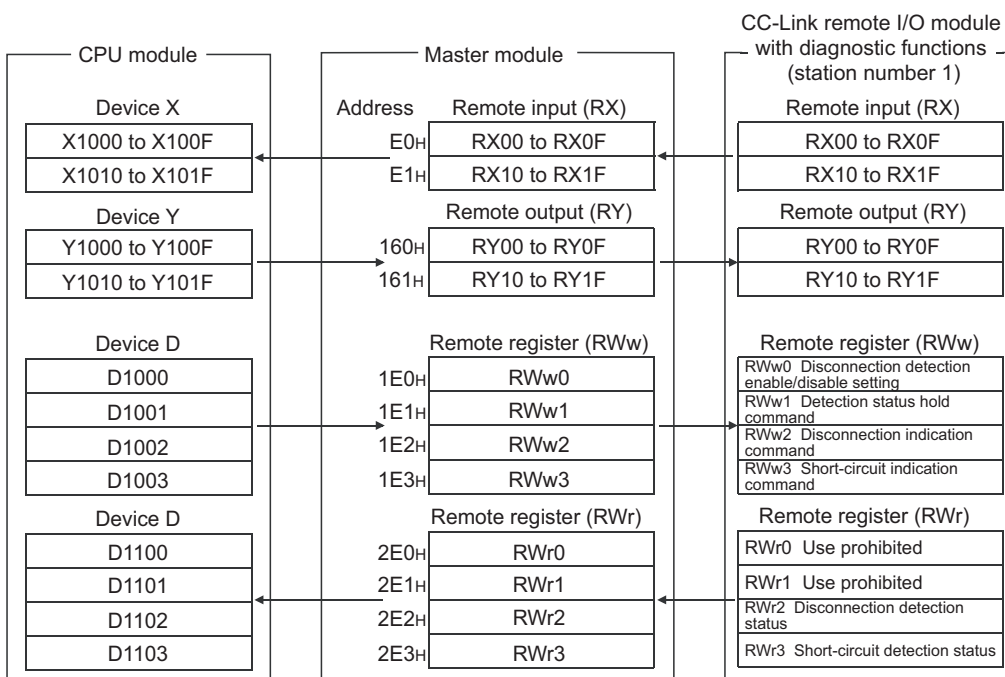

(b) For the ACPU and QCPU (A mode)

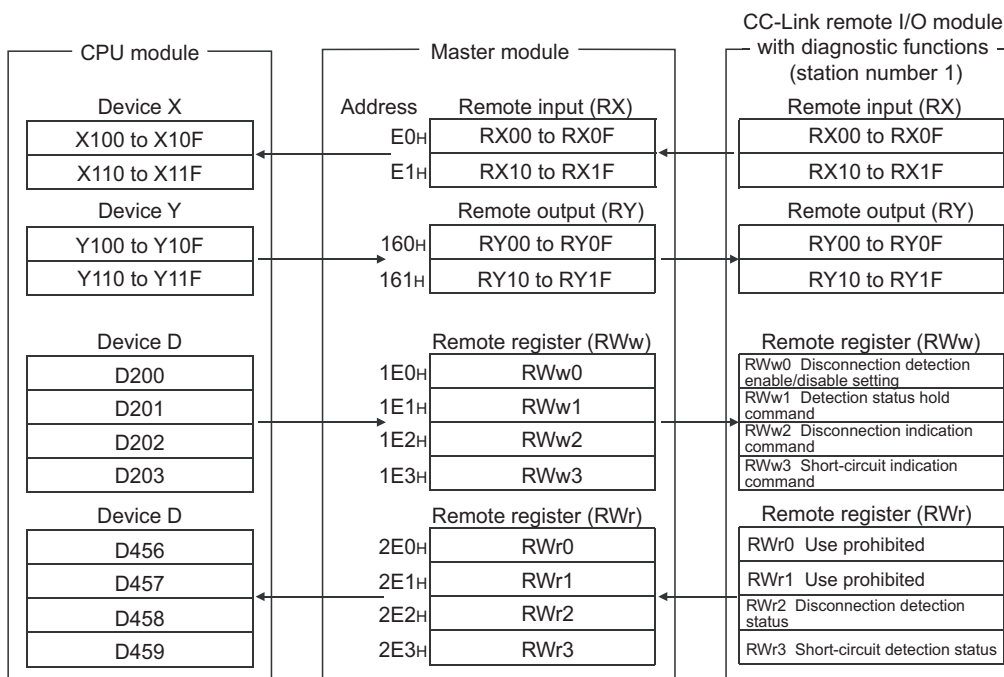

Point

The devices used in the program examples introduced in this chapter may not be available depending on the CPU module used.
 For the available device setting ranges, refer to the user's manual for the CPU module used.
 For example, X100 or Y100 and the subsequent devices are not available for the A1SCPU. Use other devices such as B and M.

(4) Initial setting item

Item	Description
Disconnection detection enable/disable setting (RWw0)	Disconnection detection is enabled only for X0.

6.3 Program Example When the QCPU (Q Mode) is Used

Parameters can be set in "Network Parameter" of GX Works2.

Initial setting can be easily configured using the remote device station initialization procedure registration function.

(1) Parameter settings

(a) Network parameter setting

1. Open the Network Parameter setting window and set parameters as follows.

 Project window ⇨ [Parameter] ⇨ [Network Parameter] ⇨ [CC-Link]

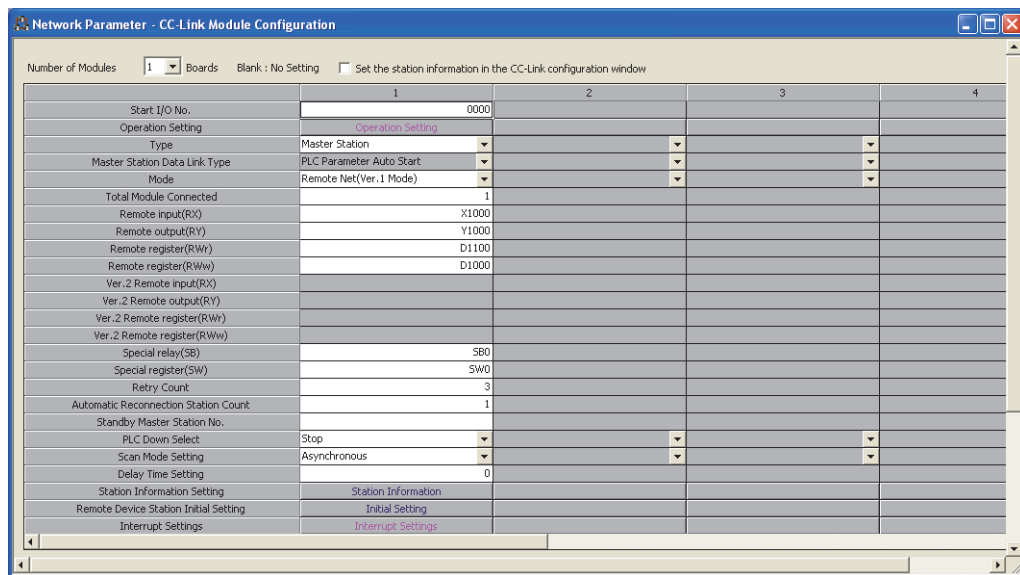

Item	Setting value
Number of Modules	1 (Boards)
Start I/O No.	0000
Operation Setting	No Setting
Type	Master Station
Mode	Remote Net (Ver.1 Mode)
Total Module Connected	1
Remote Input (RX)	X1000
Remote Output (RY)	Y1000
Remote Register (RWr)	D1100
Remote Register (RWw)	D1000
Special Relay (SB)	SB0
Special Register (SW)	SW0
Retry Count	3
Automatic Reconnection Station Count	1
Standby Master Station No.	No Setting
PLC Down Select	Stop
Scan Mode Setting	Asynchronous
Delay Time Setting	0
Station Information Setting	 Page 85, Section 6.3 (1) (b)

Item	Setting value
Remote Device Station Initial Setting	 Page 86, Section 6.3 (2)
Interrupt Settings	No Setting

(b) Station information setting

1. Open the Station Information setting window and set parameters as follows.

 Project window ⇨ [Parameter] ⇨ [Network Parameter] ⇨ [CC-Link] ⇨ [Station Information]

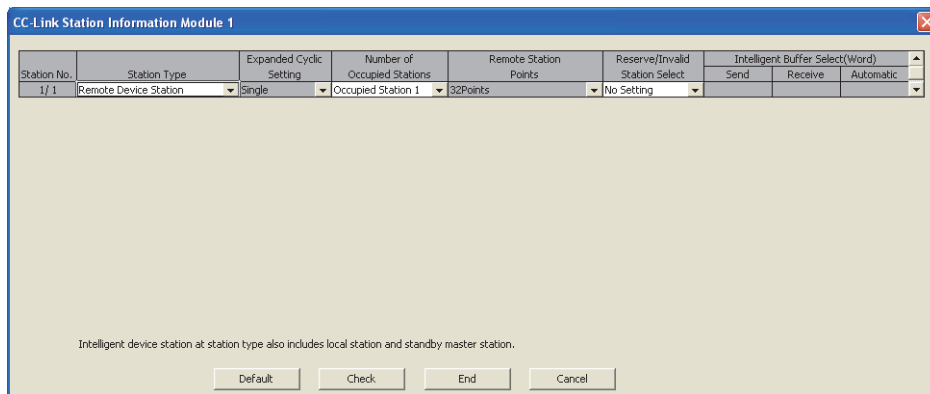

Item	Setting value
Station Type	Remote Device Station
Number of Occupied Stations	Occupied Station 1
Reserve/Invalid Station Select	No Setting

(2) Initial setting using the remote device station initialization procedure registration function

1. Open the Remote Device Station Initial Setting window and set parameters as follows.

Project window ⇨ [Parameter] ⇨ [Network Parameter] ⇨ [CC-Link] ⇨ [Initial Setting]

	Target Station No.	No. of Registered Procedures		Target Station No.	No. of Registered Procedures	
1	1	0	Regist Procedure	9		Regist Procedure
2			Regist Procedure	10		Regist Procedure
3			Regist Procedure	11		Regist Procedure
4			Regist Procedure	12		Regist Procedure
5			Regist Procedure	13		Regist Procedure
6			Regist Procedure	14		Regist Procedure
7			Regist Procedure	15		Regist Procedure
8			Regist Procedure	16		Regist Procedure

Clear Check End Cancel

2. Open the Procedure Registration setting window and set parameters as follows.

Project window ⇨ [Parameter] ⇨ [Network Parameter] ⇨ [CC-Link] ⇨ [Initial Setting] ⇨ [Regist Procedure]

Execute Flag	Operational Condition	Executional Condition			Details of Execution		
		Condition Device	Device No.	Execute Condition	Write Device	Device No.	Write Data
Execute	Set New	RX	18	ON	RWw	00	0001
Execute	Same as Prev.Set	RX	18	ON	RY	18	ON
Execute	Same as Prev.Set	RX	18	ON	RY	19	ON
Execute	Set New	RX	18	OFF	RY	18	OFF
Execute	Set New	RX	19	ON	RY	19	OFF
Execute	Set New						
Execute	Set New						
Execute	Set New						
Execute	Set New						
Execute	Set New						
Execute	Set New						
Execute	Set New						
Execute	Set New						
Execute	Set New						
Execute	Set New						
Execute	Set New						

Default Check End Cancel

- When Initial data processing request flag (RX18) turns on and Remote device station initialization procedure registration command (SB0D) subsequently turns on, the following operations are registered to the CC-Link remote I/O module with diagnostic functions.

Condition	Operation
Initial data processing request flag (RX18) turns on.	Disconnection detection enable/disable setting: Enabled only for X0 (RWw0: 0001 _H)
	Turns on Initial data processing completion flag (RY18).
	Turns on Initial data setting request flag (RY19).
Initial data processing request flag (RX18) turns off.	Turns off Initial data processing completion flag (RY18).
Initial data setting completion flag (RX19) turns on.	Turns off Initial data setting request flag (RY19).

Remark

The master module can perform initial processing only for the specified remote device stations. For details, refer to the following.

 MELSEC-Q CC-Link System Master/Local Module User's Manual

(3) Devices used in the program example

Device	Description
X0	Module error
X1	Data link status of host station
XF	Module READY
X20	LED disconnection/short-circuit indication hold reset command
X22	Signal that is turned on to change the initial settings
X23	Disconnection detection number reset command for an external input signal, X0
X1000	External input signal, X0, for the CC-Link remote I/O module with diagnostic functions
X1018	Initial data processing request flag
X1019	Initial data setting completion flag
X101B	Remote READY
Y60	Signal that is output when a data link error occurs
Y61	Signal that is output when an external input signal, X0, is on
Y62	Signal that is output when an external input signal, X0, is disconnected or shorted
Y1019	Initial data setting request flag
M0	Signal that stores the data link status of the CC-Link remote I/O module with diagnostic functions <ul style="list-style-type: none"> • 0 (OFF): Data link is normal. • 1 (ON): A data link error occurs.
M1 to M3	Not used (data link status of Station 2 to Station 4)
M100	Master control contact
D42	Result of disconnection detections
D43	Result of short-circuit detections
D60	Number of disconnection detections for an external input signal, X0
D1000	Disconnection detection enable/disable setting
D1001	Detection status hold command
D1002	Disconnection indication command
D1003	Short-circuit indication command
D1102	Disconnection detection status
D1103	Short-circuit detection status
SW80	Data link status of other stations
SB0D	Remote device station initialization procedure registration command
SB5F	Remote device station initialization procedure execution completion status

(4) Program example

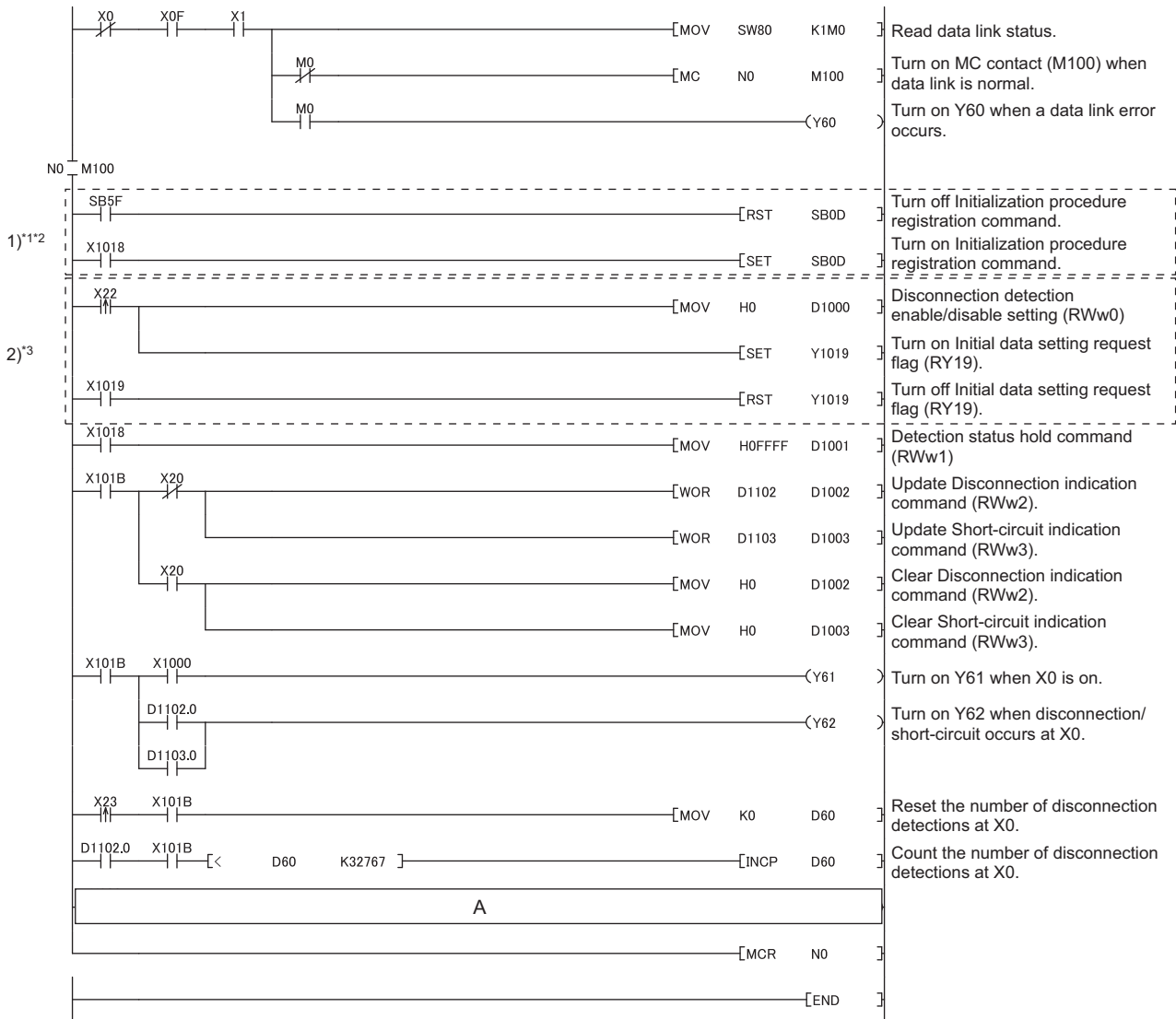

- *1 To perform a remote device station initialization procedure registration to multiple stations, refer to the following and correct the program in the dotted-line area 1).
 Page 91, Section 6.3 (5)
- *2 The program in the dotted-line area 1) enables the initial settings that are done by using the following devices, before the master station executes a communication program with remote device stations. Initial processing is not performed only with the parameter settings of GX Works2.
 - Remote device station initialization procedure registration command (SB0D)
 - Remote device station initialization procedure execution completion status (SB5F)
- *3 Use the program in the dotted-line area 2) only to change the initial settings.

6

6.3 Program Example When the QCPU (Q Mode) is Used

(a) When "Hold the detection status (0)" is set to Detection status hold command (RWw1)

Add the following program to the part A in the program shown on Page 89, Section 6.3 (4).

In the following program, use Result of disconnection detections (D42) and Result of short-circuit detections (D43) to check the disconnection or short-circuit status.

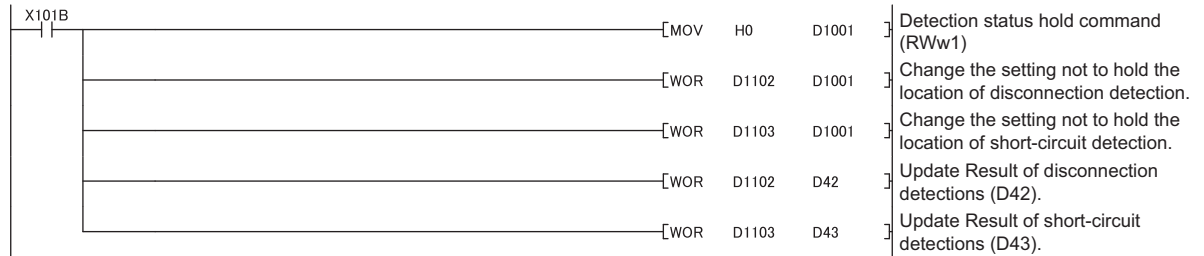

(5) Performing a remote device station initialization procedure registration to multiple stations

Correct the program described in Page 89, Section 6.3 (4), the part enclosed by the dotted line 1), as shown below.

- System configuration

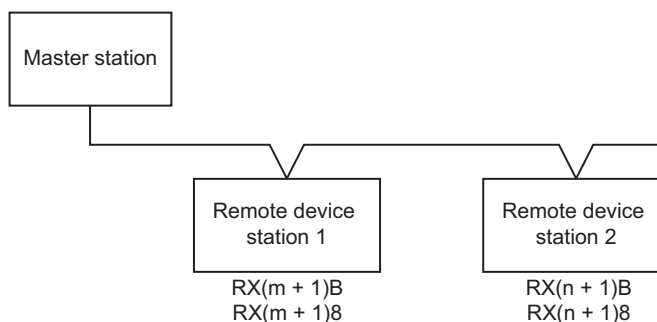

- Correction program

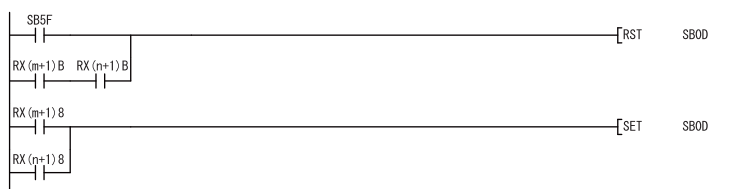

Device	Description
RX(m+1)B	Remote READY
RX(n+1)B	
RX(m+1)8	Initial data processing request flag
RX(n+1)8	

Add Remote READY and Initial data processing request flag for all the stations, to which the remote device station initialization procedure registration has been made, to the program as an interlock.

If the following modules are used as remote device stations, configure initial settings of these stations using a sequence program.

- AJ65BT-64AD analog-digital converter module
- AJ65BT-68TD thermocouple temperature input module
- AJ65BT-64RD3 platinum temperature-measuring resistor Pt100 temperature input module
- AJ65BT-64RD4 platinum temperature-measuring resistor Pt100 temperature input module

The above correction program does not apply to these stations because the condition where Remote READY turns on differs between the CC-Link remote I/O module with diagnostic functions and these remote device stations.

(6) Application program (program for storing disconnection/short-circuit detection history)

(a) Programming conditions

- Adding this program to the program shown on Page 89, Section 6.3 (4) enables users to check the history of disconnection/short-circuit detection at X0.
- A file register needs to be set for this program. For the setting method, refer to the user's manual for the CPU module used.
- The disconnection/short-circuit detection history area, which is used in a program example, has a ring buffer structure for storing 10 logs. The data structure is shown below.

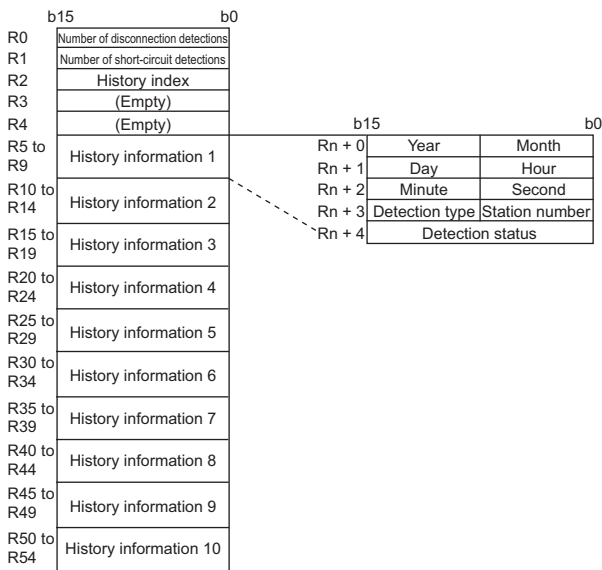

Item	Description
Number of disconnection detections	The number of disconnection detections (accumulated total) is stored.
Number of short-circuit detections	The number of short-circuit detections (accumulated total) is stored.
History index	The index is used to decide the storage location of the detection history when disconnection/short-circuit is detected.
Year/Month/Day/Hour/Minute/Second	The detection date is stored in BCD. These data are stored by using clock information of the CPU module.
Detection type	<ul style="list-style-type: none"> · If disconnection is detected, 01H is stored. · If short-circuit is detected, 02H is stored.
Station number	The station number of CC-Link remote I/O module with diagnostic functions, which detected disconnection/short-circuit, is stored.
Detection status	<ul style="list-style-type: none"> · If disconnection is detected, the value of Disconnection detection status (RWr2) is stored. · If short-circuit is detected, the value of Short-circuit detection status (RWr3) is stored.

(b) Device list

The following table lists devices used only in this program.

For details on other devices, refer to the following.

 Page 88, Section 6.3 (3)

Device	Description
X21	Clear request of disconnection/short-circuit detection history
M31	Write request of disconnection/short-circuit detection history
D30	Data for writing history information (detection type/station number)
D31	Data for writing history information (detection status)
Z0	Index register for writing disconnection/short-circuit detection history
R0 to R54	Disconnection/short-circuit detection history

(c) Program example

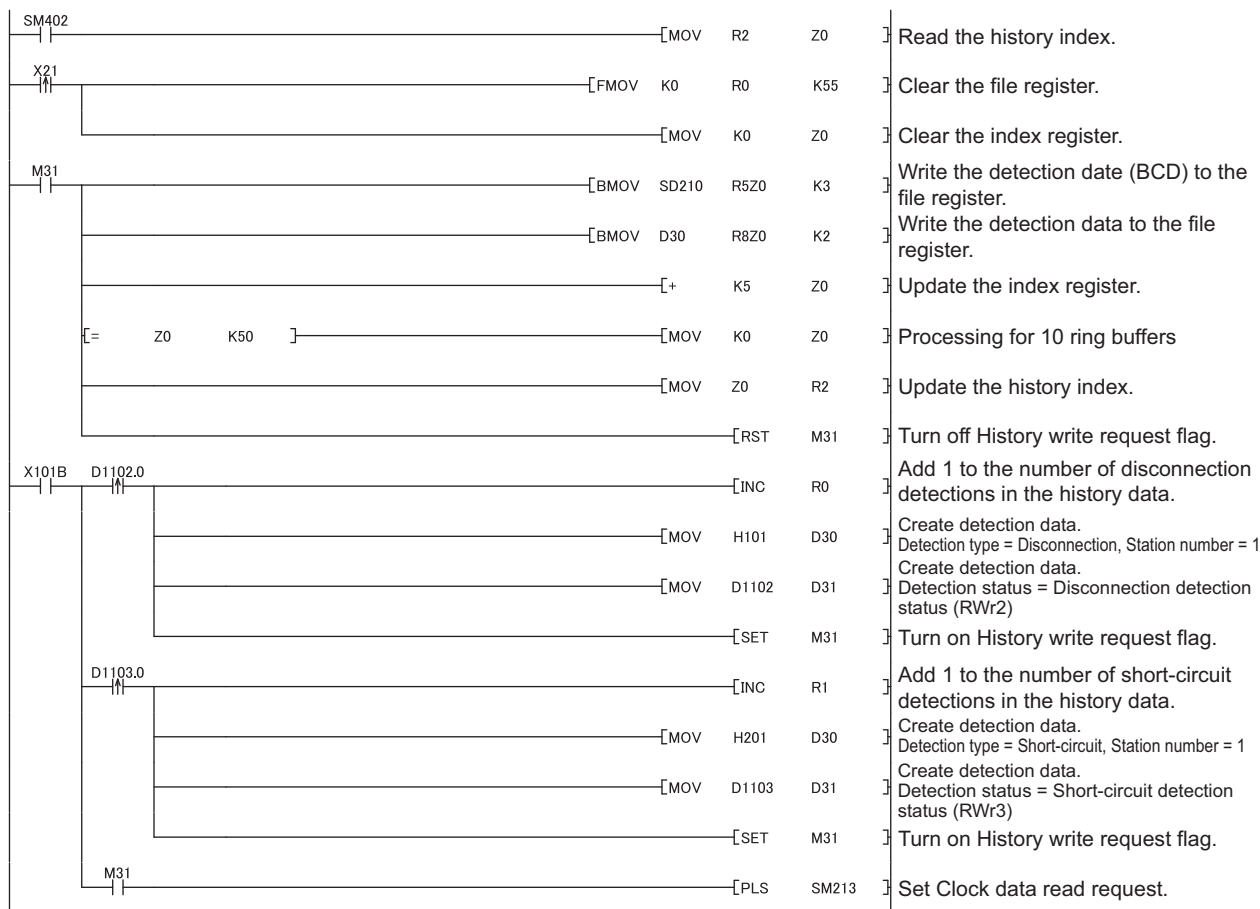

6

6.3 Program Example When the QCPU (Q Mode) is Used

6.4 Program Example When the LCPU is Used

When the LCPU is used, the program example for the QCPU can be used. Set parameters according to the descriptions in this section and apply the following program example.

☞ Page 89, Section 6.3 (4)

Parameters can be set in "Network Parameter" of GX Works2.

(1) Parameter settings

(a) PLC parameter

Change the I/O assignment setting of the built-in I/O function according to the program example for the QCPU. In the "I/O Assignment" tab from "PLC Parameter", assign a start I/O address that is not used in the system. The following shows an example of I/O assignment for the L02CPU.

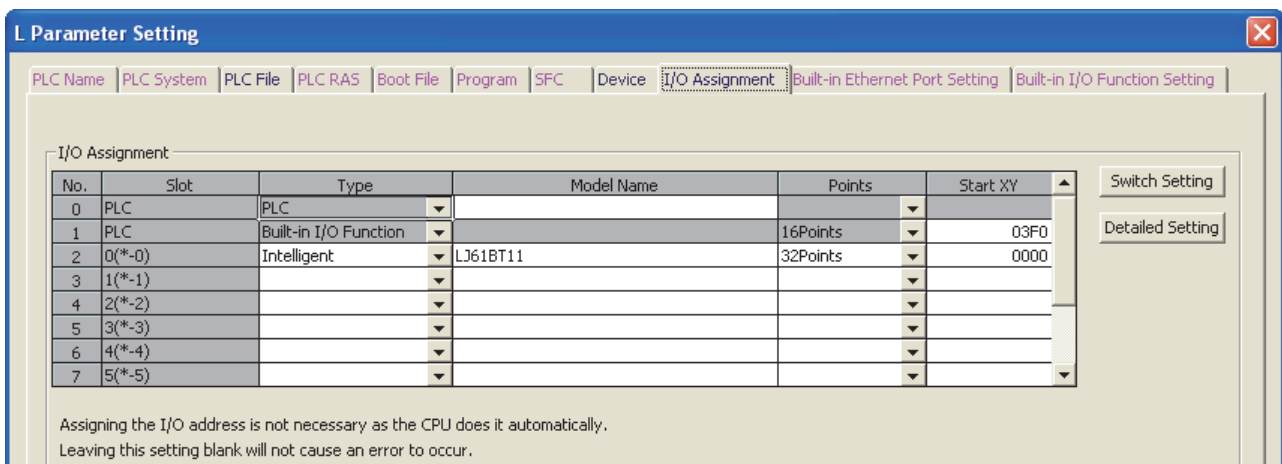

No.	Slot	Type	Model Name	Points	Start XY
0	PLC	PLC			
1	PLC	Built-in I/O Function		16Points	03F0
2	0(*-0)	Intelligent	LJ61BT11	32Points	0000
3	1(*-1)				
4	2(*-2)				
5	3(*-3)				
6	4(*-4)				
7	5(*-5)				



Assigning the I/O address is not necessary as the CPU does it automatically.
Leaving this setting blank will not cause an error to occur.

When the LCPU with the built-in CC-Link function is used, set the start I/O address for the built-in CC-Link function to "0000" and assign a start I/O address that is not used in the system for the built-in I/O function.

(b) Network parameter setting**1. Open the Network Parameter setting window and set parameters as follows.**

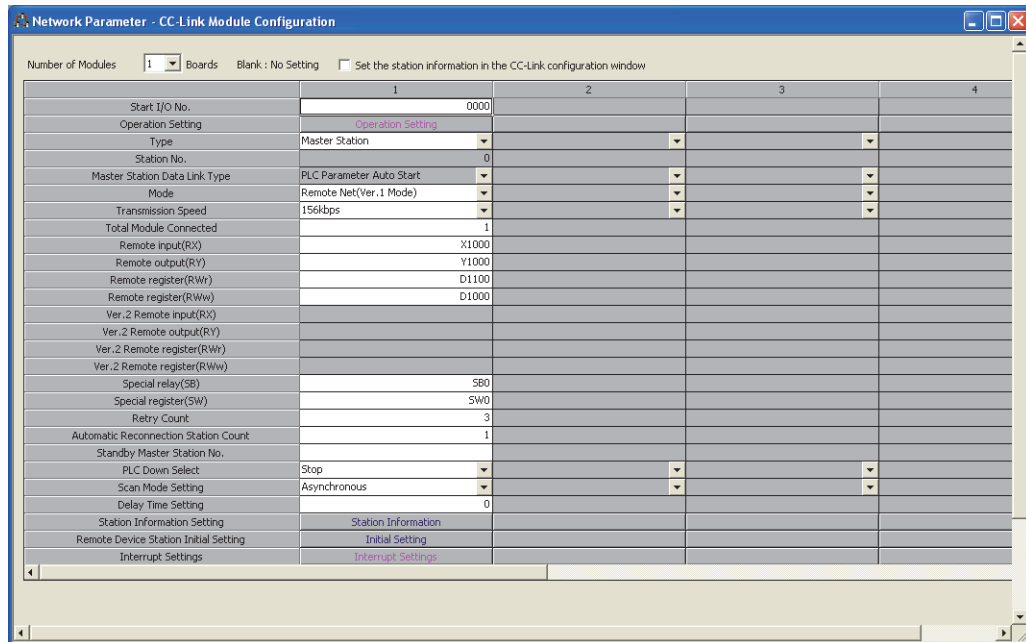
 Project window ⇨ [Parameter] ⇨ [Network Parameter] ⇨ [CC-Link]



Item	Setting value
Number of Modules	1 (Boards)
Start I/O No.	0000
Operation Setting	No Setting
Type	Master Station
Mode	Remote Net (Ver.1 Mode)
Transmission Speed	156kbps
Total Module Connected	1
Remote Input (RX)	X1000
Remote Output (RY)	Y1000
Remote Register (RWr)	D1100
Remote Register (RWw)	D1000
Special Relay (SB)	SB0
Special Register (SW)	SW0
Retry Count	3
Automatic Reconnection Station Count	1
Standby Master Station No.	No Setting
PLC Down Select	Stop
Scan Mode Setting	Asynchronous
Delay Time Setting	0
Station Information Setting	 Page 96, Section 6.4 (1) (c)
Remote Device Station Initial Setting	 Page 97, Section 6.4 (2)
Interrupt Settings	No Setting

(c) Station information setting

1. Open the Station Information setting window and set parameters as follows.

Project window ⇨ [Parameter] ⇨ [Network Parameter] ⇨ [CC-Link] ⇨ [Station Information]

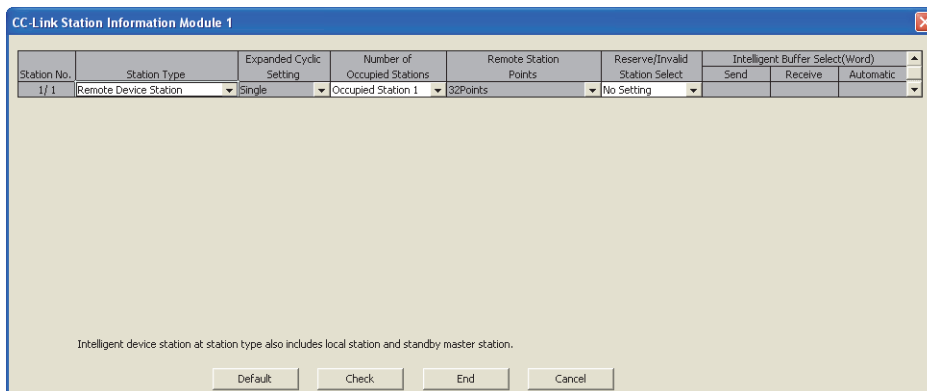

Item	Setting value
Station Type	Remote Device Station
Number of Occupied Stations	Occupied Station 1
Reserve/Invalid Station Select	No Setting

(2) Initial setting using the remote device station initialization procedure registration function

1. Open the Remote Device Station Initial Setting window and set parameters as follows.

Project window ⇨ [Parameter] ⇨ [Network Parameter] ⇨ [CC-Link] ⇨ [Initial Setting]

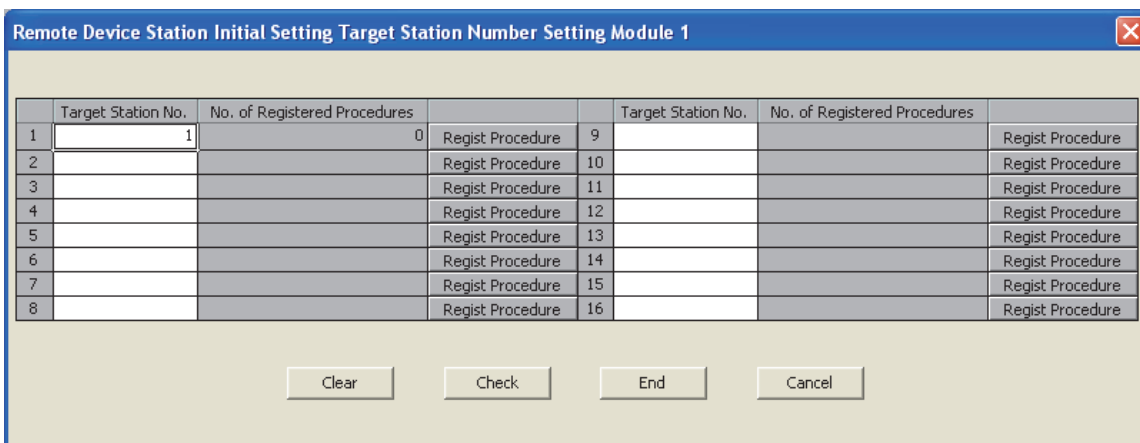

2. Open the Procedure Registration setting window and set parameters as follows.

Project window ⇨ [Parameter] ⇨ [Network Parameter] ⇨ [CC-Link] ⇨ [Initial Setting] ⇨ [Regist Procedure]

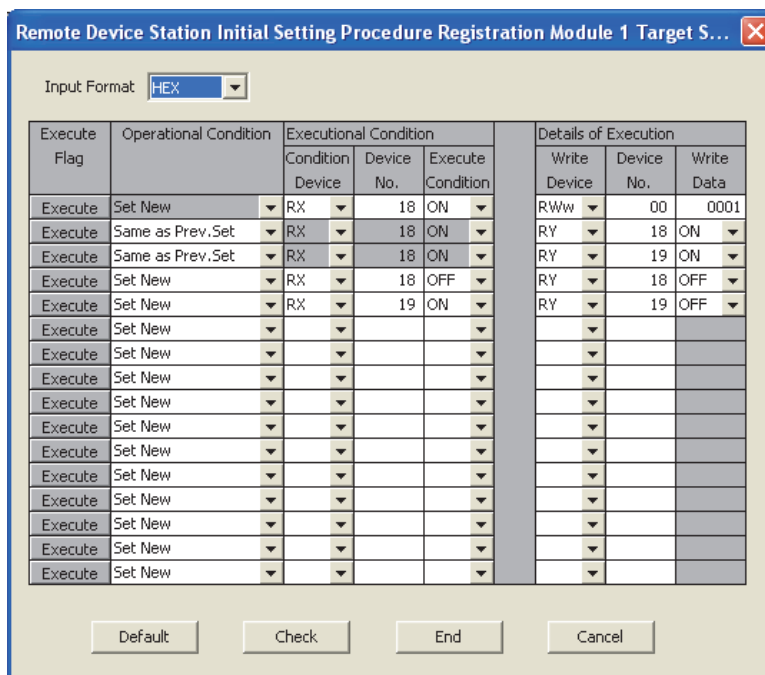

- When Initial data processing request flag (RX18) turns on and Remote device station initialization procedure registration command (SB0D) subsequently turns on, the following operations are registered to the CC-Link remote I/O module with diagnostic functions.

Condition	Operation
Initial data processing request flag (RX18) turns on.	Disconnection detection enable/disable setting: Enabled only for X0 (RWw0: 0001 _H)
	Turns on Initial data processing completion flag (RY18).
	Turns on Initial data setting request flag (RY19).
Initial data processing request flag (RX18) turns off.	Turns off Initial data processing completion flag (RY18).
Initial data setting completion flag (RX19) turns on.	Turns off Initial data setting request flag (RY19).

Remark

The master module can perform initial processing only for the specified remote device stations. For details, refer to the following.

 MELSEC-L CC-Link System Master/Local Module User's Manual

(3) Program example

Refer to the following and apply the program example.

 Page 88, Section 6.3 (3), Page 89, Section 6.3 (4), Page 91, Section 6.3 (5), Page 92, Section 6.3 (6)

Remark

To configure the system with the default I/O assignment of the LCPU, change some devices listed on Page 88, Section 6.3 (3) and Page 92, Section 6.3 (6), Section 6.3 (6) to the ones in the following table.

Device	Alternative device	Description
X0	X10	Module error
X1	X11	Data link status of host station
XF	X1F	Module READY
X20	X30	LED disconnection/short-circuit indication hold reset command
X21	X31	Clear request of disconnection/short-circuit detection history
X22	X32	Signal that is turned on to change the initial settings
X23	X33	Disconnection detection number reset command for an external input signal, X0

6.5 Program Example When the QnACPU is Used

Parameters can be set in "Network parameter" of GX Developer.

(1) Parameter settings

(a) Network parameter setting

1. Open the Network parameters setting window and set parameters as follows.

 Project data list ⇨ [Parameter] ⇨ [Network parameter] ⇨ [CC-Link]

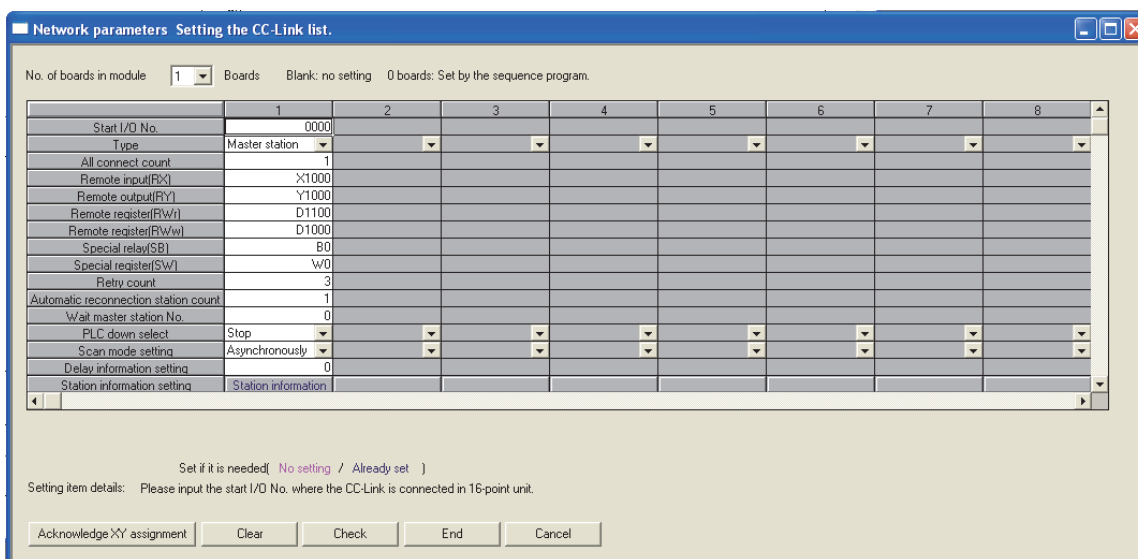

Item	Setting value
No. of boards in module	1 (Boards)
Start I/O No.	0000
Type	Master station
All connect count	1
Remote input (RX)	X1000
Remote output (RY)	Y1000
Remote register (RWr)	D1100
Remote register (RWw)	D1000
Special relay (SB)	B0
Special register (SW)	W0
Retry count	3
Automatic reconnection station count	1
Wait master station No.	0
PLC down select	Stop
Scan mode setting	Asynchronously
Delay information setting	0
Station information setting	 Page 100, Section 6.5 (2)

(2) Station information setting

1. Open the station information setting window and set parameters as follows.

🖱️ Project data list ⇨ [Parameter] ⇨ [Network parameter] ⇨ [CC-Link] ⇨ [Station information]

StationNo.	Station type	Exclusive station count	Reserve/invalid station select	Intelligent buffer select(word)		
				Send	Receive	Automatic
1/1	Remote device station	Exclusive station 1	No setting			

Default Check End Cancel

Item	Setting value
Station type	Remote device station
Exclusive station count	Exclusive station 1
Reserve/invalid station select	No setting

(3) Devices used in the program example

Device	Description
X0	Module error
X1	Data link status of host station
XF	Module READY
X20	LED disconnection/short-circuit indication hold reset command
X22	Signal that is turned on to change the initial settings
X23	Disconnection detection number reset command for an external input signal, X0
X1000	External input signal, X0, for the CC-Link remote I/O module with diagnostic functions
X1018	Initial data processing request flag
X1019	Initial data setting completion flag
X101B	Remote READY
Y60	Signal that is output when a data link error occurs
Y61	Signal that is output when an external input signal, X0, is on
Y62	Signal that is output when an external input signal, X0, is disconnected or shorted
Y1018	Initial data processing completion flag
Y1019	Initial data setting request flag
M0	Signal that stores the data link status of the CC-Link remote I/O module with diagnostic functions <ul style="list-style-type: none"> • 0 (OFF): Data link is normal. • 1 (ON): A data link error occurs.
M1 to M3	Not used (data link status of Station 2 to Station 4)
M100	Master control contact
D42	Result of disconnection detections
D43	Result of short-circuit detections
D60	Number of disconnection detections for an external input signal, X0
D1000	Disconnection detection enable/disable setting
D1001	Detection status hold command
D1002	Disconnection indication command
D1003	Short-circuit indication command
D1102	Disconnection detection status
D1103	Short-circuit detection status
W80	Data link status of other stations

(4) Program example

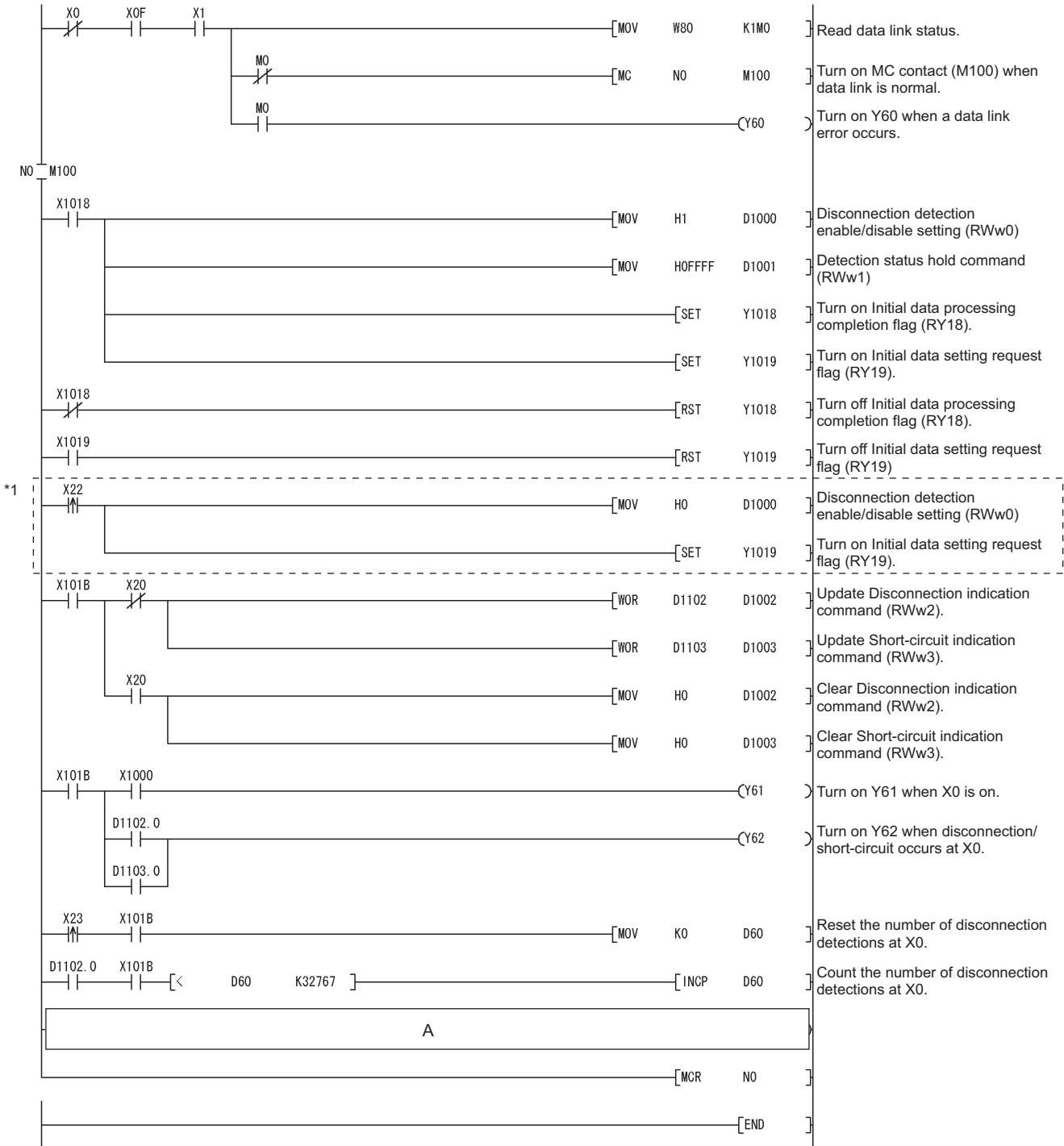

*1 Use the program in the dotted-line area only to change the initial settings.

(a) When "Hold the detection status (0)" is set to Detection status hold command (RWw1)

Add the following program to the part A in the program shown on Page 102, Section 6.5 (4).

In the following program, use Result of disconnection detections (D42) and Result of short-circuit detections (D43) to check the disconnection or short-circuit status.

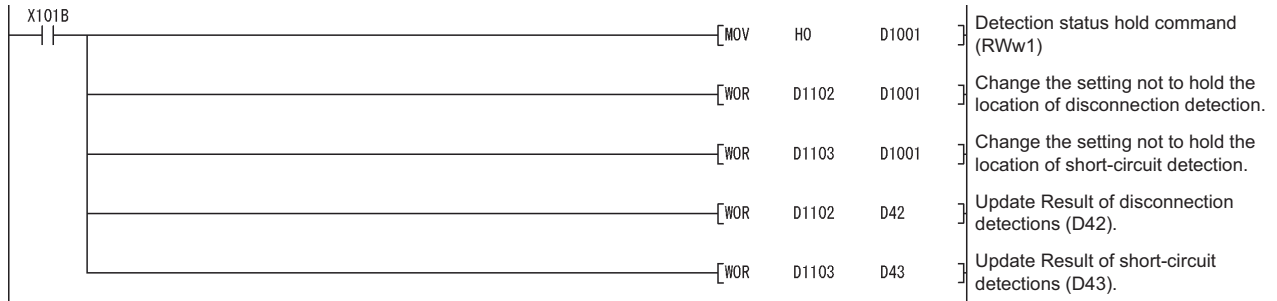

6.6 Program Example When the ACPU/QCPU (A Mode) is Used (Dedicated Instructions)

Parameters can be set with a sequence program.

For details on dedicated instructions, refer to the following.

 Type AnSHCPU/AnACPU/AnUCPU/QCPU-A (A Mode) Programming Manual (Dedicated Instructions)

(1) Devices used in the program example

Device	Description
X0	Module error
X1	Data link status of host station
XF	Module READY
X20	LED disconnection/short-circuit indication hold reset command
X22	Signal that is turned on to change the initial settings
X23	Disconnection detection number reset command for an external input signal, X0
X100	External input signal, X0, for the CC-Link remote I/O module with diagnostic functions
X118	Initial data processing request flag
X119	Initial data setting completion flag
X11B	Remote READY
Y60	Signal that is output when a data link error occurs
Y61	Signal that is output when an external input signal, X0, is on
Y62	Signal that is output when an external input signal, X0, is disconnected or shorted
Y118	Initial data processing completion flag
Y119	Initial data setting request flag
M0	Network parameter setting start pulse signal
M1	Signal that turns on when the parameter setting is completed normally
M2	Signal that turns on when the parameter setting is completed in error
M3	Auto refresh parameter setting start pulse signal
M4	Signal that stores the data link status of the CC-Link remote I/O module with diagnostic functions <ul style="list-style-type: none"> • 0 (OFF): Data link is normal. • 1 (ON): A data link error occurs.
M5 to M7	Not used (data link status of Station 2 to Station 4)
M8	Initial setting change command pulse signal
M9	Pulse signal (Disconnection detection number reset command for an external input signal, X0)
M100	Master control contact
M300 to M315	Disconnection detection status
M400 to M415	Short-circuit detection status
D0 to D2	Device for network parameter settings
D3	Device where the parameter status of host station is stored when the instruction is completed in error
D10 to D29	Device for auto refresh parameter settings
D42	Result of disconnection detections
D43	Result of short-circuit detections
D60	Number of disconnection detections for an external input signal, X0
D200	Disconnection detection enable/disable setting

Device	Description
D201	Detection status hold command
D202	Disconnection indication command
D203	Short-circuit indication command
D458	Disconnection detection status
D459	Short-circuit detection status
W80	Data link status of other stations

(2) Program example

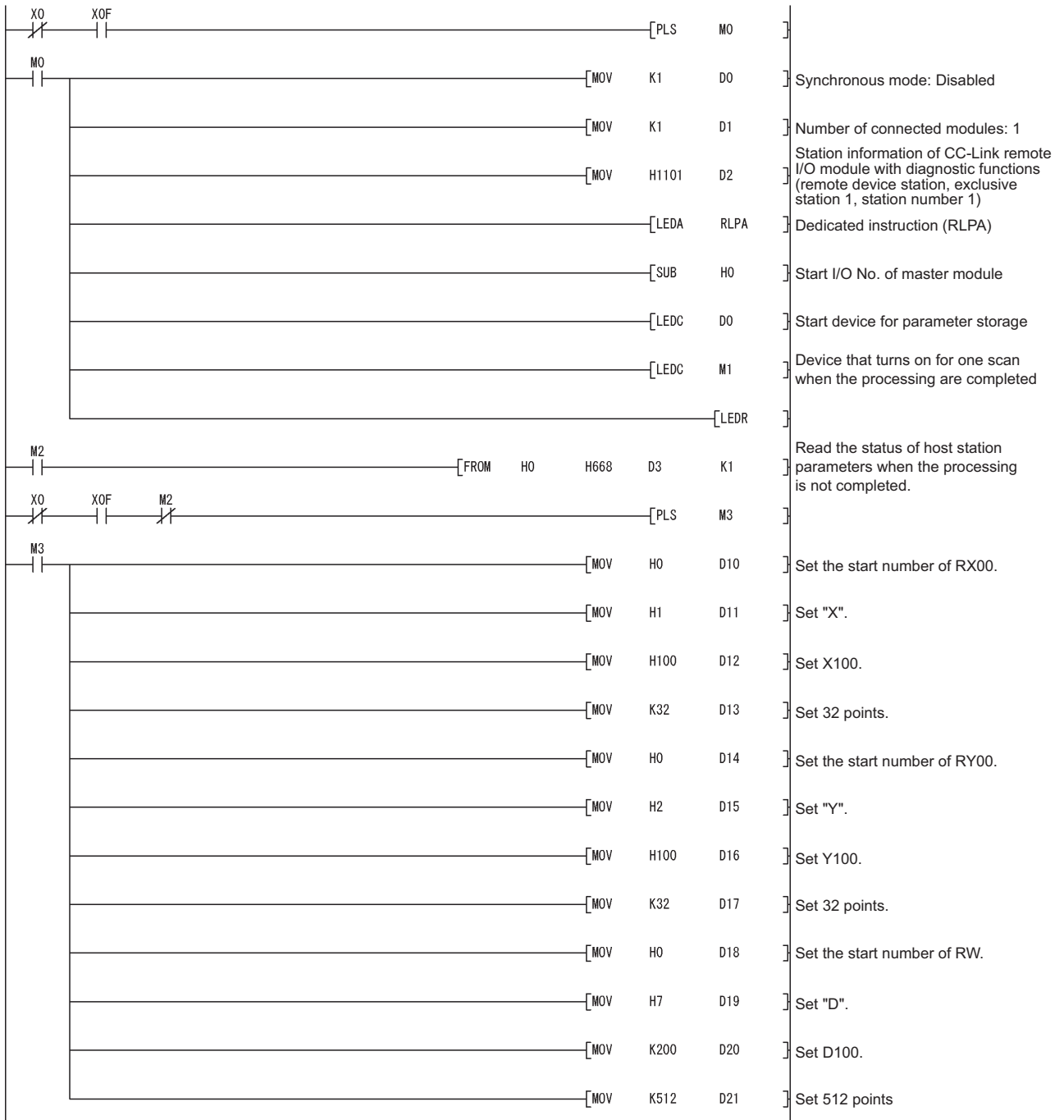

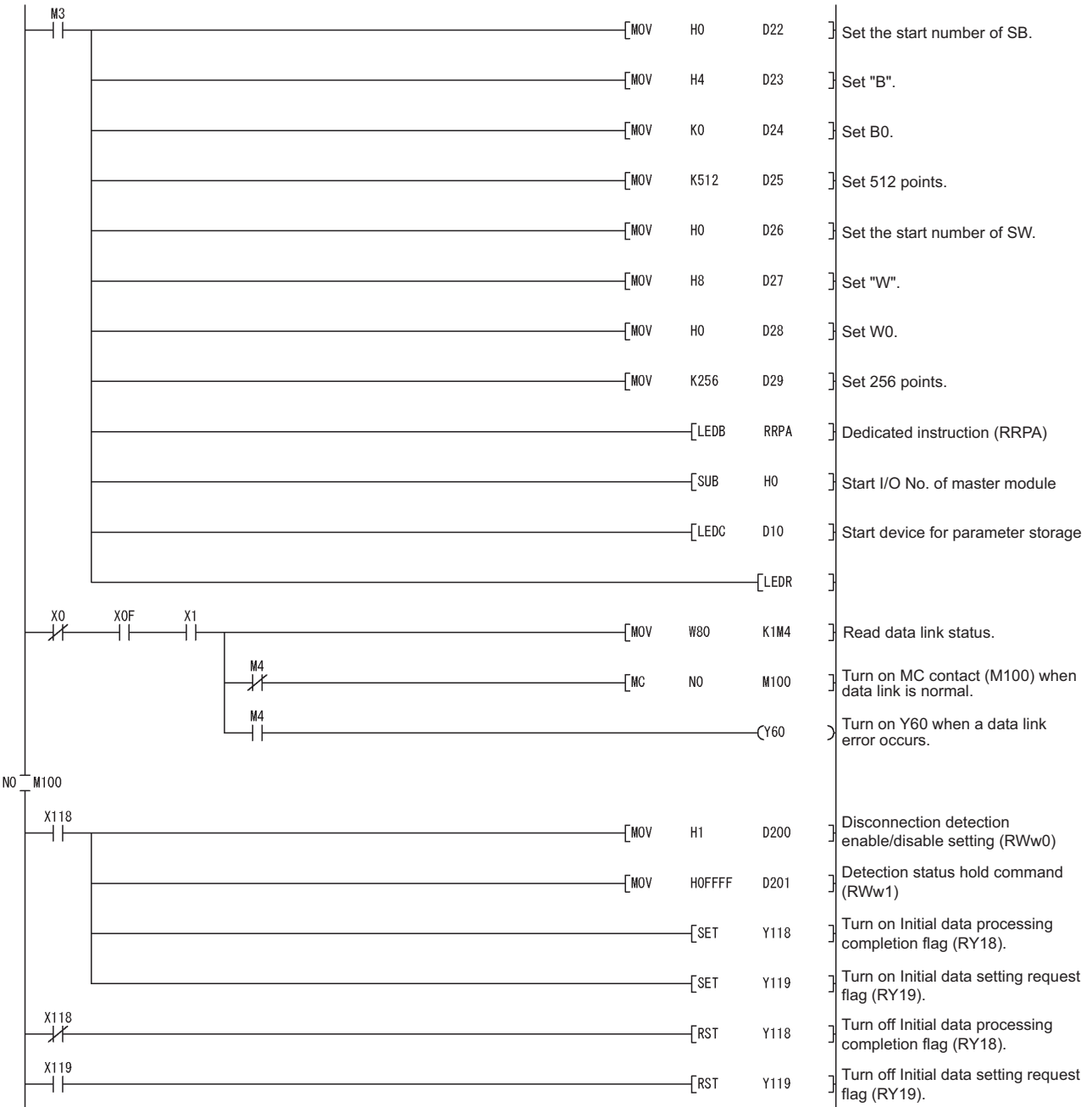

6.6 Program Example When the ACPU/QCPU (A Mode) is Used (Dedicated Instructions)

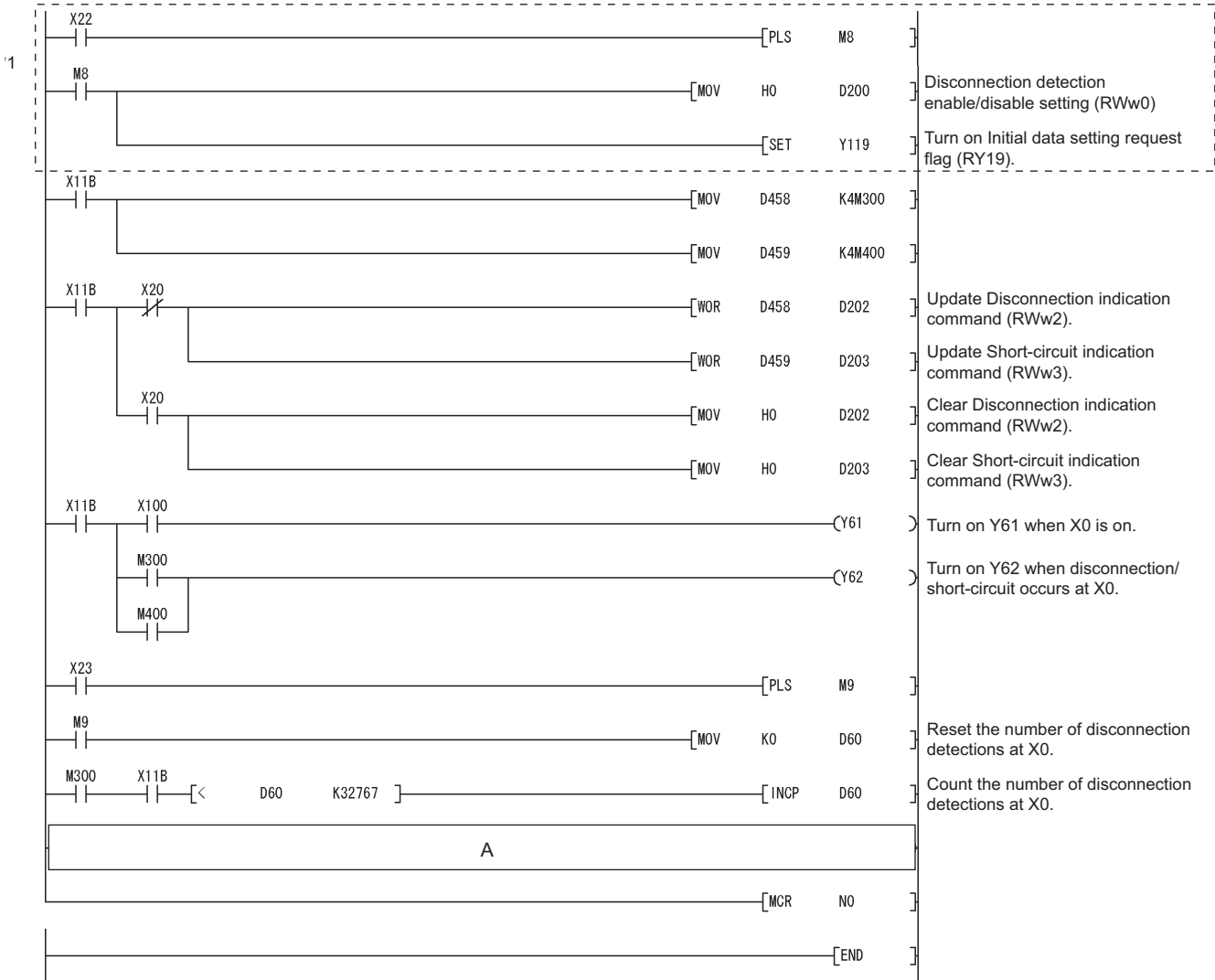

*1 Use the program in the dotted-line area only to change the initial settings.

(a) When "Hold the detection status (0)" is set to Detection status hold command (RWw1)

Add the following program to the part A in the program shown on Page 106, Section 6.6 (2).

In the following program, use Result of disconnection detections (D42) and Result of short-circuit detections (D43) to check the disconnection or short-circuit status.

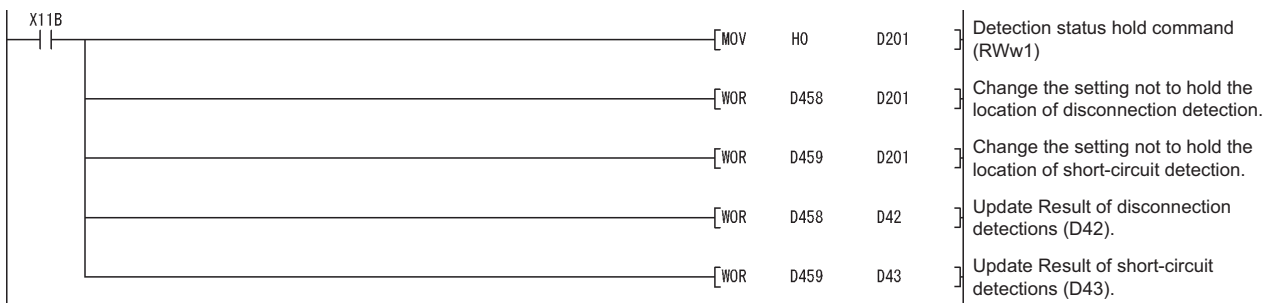

6.7 Program Example When the ACPU/QCPU (A Mode) is Used (FROM/TO Instructions)

Parameters can be set with a sequence program.

(1) Devices used in the program example

Device	Description
X0	Module error
X1	Data link status of host station
X6	Data link startup with parameters in buffer memory normally completed
X7	Data link startup with parameters in buffer memory completed in error
XF	Module READY
X20	LED disconnection/short-circuit indication hold reset command
X22	Signal that is turned on to change the initial settings
X23	Disconnection detection number reset command for an external input signal, X0
X100	External input signal, X0, for the CC-Link remote I/O module with diagnostic functions
X118	Initial data processing request flag
X119	Initial data setting completion flag
X11B	Remote READY
Y0	Refresh instruction
Y6	Request for data link startup with parameters in buffer memory
Y60	Signal that is output when a data link error occurs
Y61	Signal that is output when an external input signal, X0, is on
Y62	Signal that is output when an external input signal, X0, is disconnected or shorted
Y118	Initial data processing completion flag
Y119	Initial data setting request flag
M0	Network parameter setting start pulse signal
M4	Signal that stores the data link status of the CC-Link remote I/O module with diagnostic functions <ul style="list-style-type: none"> • 0 (OFF): Data link is normal. • 1 (ON): A data link error occurs.
M5 to M7	Not used (data link status of Station 2 to Station 4)
M8	Initial setting change command pulse signal
M9	Pulse signal (Disconnection detection number reset command for an external input signal, X0)
M100	Master control contact
M300 to M315	Disconnection detection status
M400 to M415	Short-circuit detection status
D0 to D2	Device for network parameter settings
D42	Result of disconnection detections
D43	Result of short-circuit detections
D60	Number of disconnection detections for an external input signal, X0
D112	Device where the parameter status of host station is stored when the instruction is completed in error
D200	Disconnection detection enable/disable setting
D201	Detection status hold command
D202	Disconnection indication command

Device	Description
D203	Short-circuit indication command
D458	Disconnection detection status
D459	Short-circuit detection status

(2) Program example

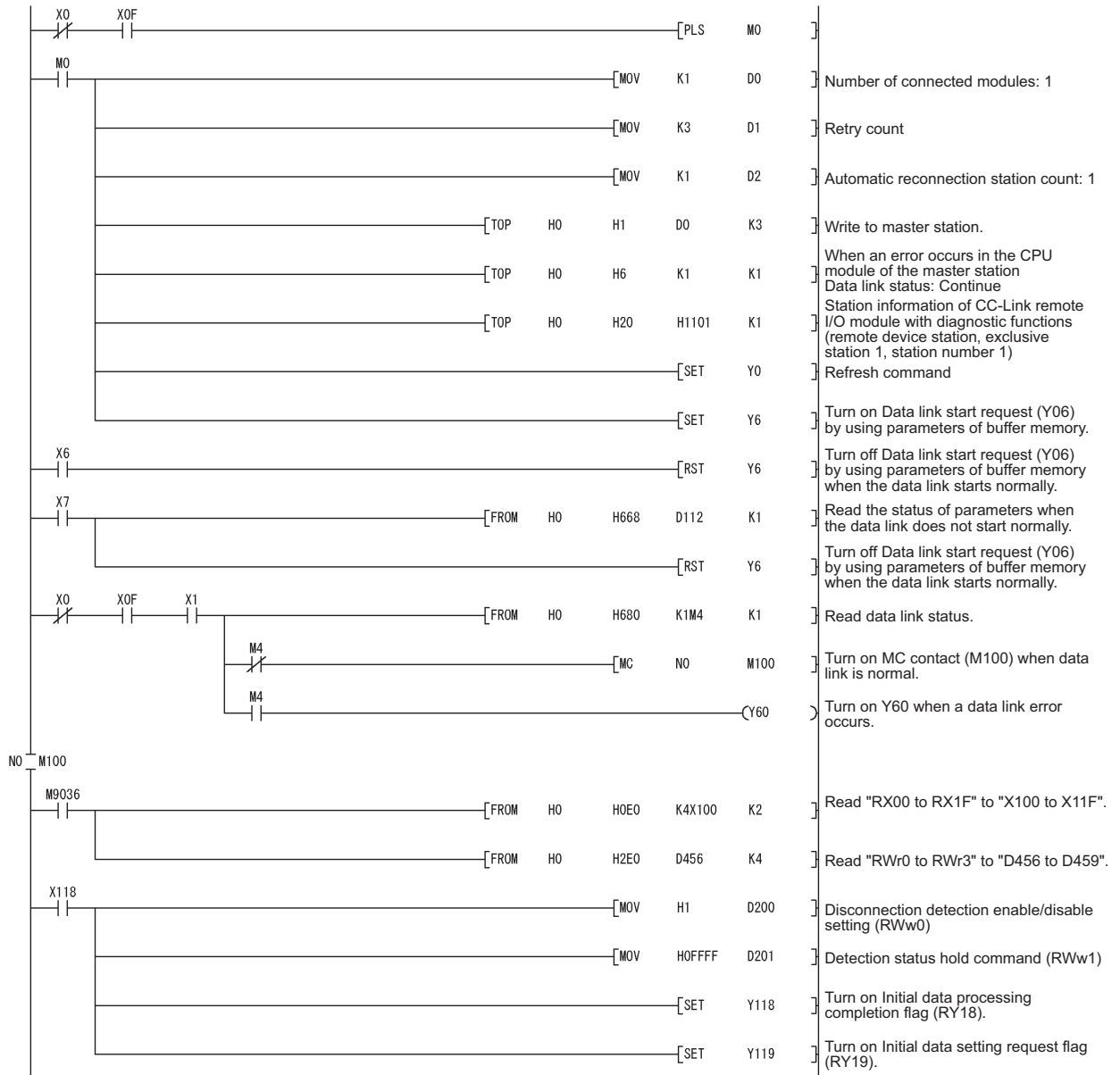

6

6.7 Program Example When the ACPU/QCPU (A Mode) is Used (FROM/TO Instructions)

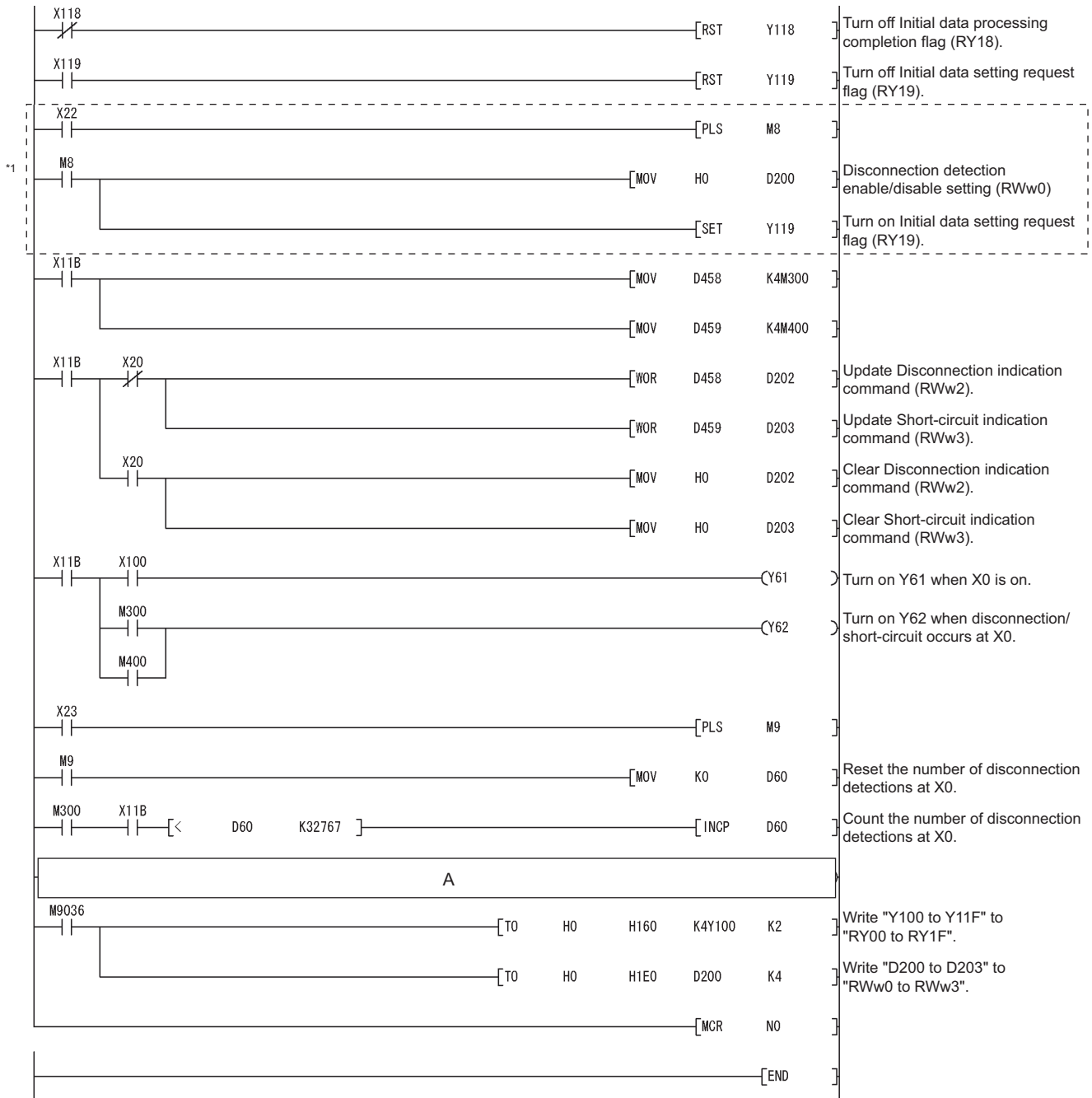

*1 Use the program in the dotted-line area only to change the initial settings.

(a) When "Hold the detection status (0)" is set to Detection status hold command (RWw1)

Add the following program to the part A in the program shown on Page 111, Section 6.7 (2).

In the following program, use Result of disconnection detections (D42) and Result of short-circuit detections (D43) to check the disconnection or short-circuit status.

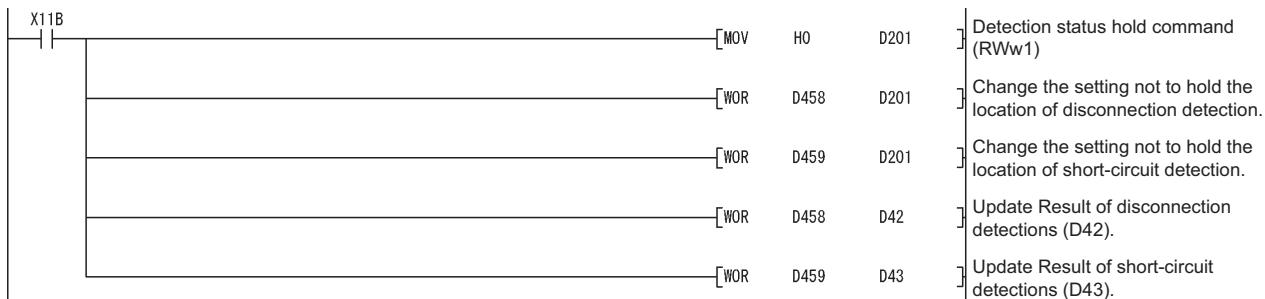

CHAPTER 7 TROUBLESHOOTING

This chapter describes errors that may occur in the use of the CC-Link remote I/O module with diagnostic functions, and the troubleshooting.

7.1 How to Check for Errors with LED Indications

This section describes how to check for errors with the LED indications of the CC-Link remote I/O module with diagnostic functions.

For errors related to the CPU module and the master module, refer to the user's manuals for the CPU module and the master module used.

(1) When the "PW" LED does not turn on

Check item	Corrective action
Are LEDs other than the "PW" LED on?	The possible cause is a hardware failure. Please consult your local Mitsubishi representative.
Is the module power supply (24VDC) wired?	Wire the module power supply (24VDC).
Is the module power supply (24VDC) on?	Turn on the module power supply (24VDC).
Is the voltage of the module power supply (24VDC) within the specified range?	Supply the voltage within the range specified in the "Performance Specifications" section. (☞ Page 26, Section 4.2)

(2) When the "I/O PW" LED does not turn on

Check item	Corrective action
Is the external power supply (24VDC) wired?	Wire the external power supply (24VDC).
Is the external power supply (24VDC) on?	Turn on the external power supply (24VDC).
Is the voltage of the external power supply (24VDC) within the specified range?	Supply the voltage within the range specified in the "Performance Specifications" section. (☞ Page 26, Section 4.2)

(3) When the "RUN" LED does not turn on

Check item	Corrective action
Has a watchdog timer error occurred?	Check whether a watchdog timer error occurred or not with the link special registers (SW0084 to SW0087) of the master module, and turn off and on the power of the CC-Link remote I/O module with diagnostic functions. If the "RUN" LED does not turn on by turning off and on the power, the possible cause is a hardware failure. Please consult your local Mitsubishi representative.

(4) When the "L RUN" LED turns off

Check item	Corrective action
Is the communication stopped?	Refer to the troubleshooting described in the user's manual for the master module used, and take the action.

(5) When the "L ERR." LED turns on

Check item	Corrective action
Is the number other than 1 to 64 set as a station number?	Set 1 to 64 for the station number.

(6) When the "L ERR." LED flashes regularly

Check item	Corrective action
Has the station number been changed while the module was operating normally?	Turn off the power of the CC-Link remote I/O module with diagnostic functions and set the station number properly. Then turn on the power.
Has the station number setting switch failed?	If the "L ERR." LED starts flashing even though the station number has not been changed during the operation, the possible cause is a hardware failure. Please consult your local Mitsubishi representative.

(7) When the "L ERR." LED flashes irregularly

Check item	Corrective action
Is the module or a CC-Link dedicated cable affected by noise?	Ground the both ends of the shielded cable (CC-Link dedicated cable) with a ground resistance of 100Ω or less with the cable connected to both SLD and FG of each module. Securely ground the FG terminal of the module. When putting the wires in a tube, ground the tube securely.
Has the station number been changed while the communication was disconnected?	Turn off the power of the CC-Link remote I/O module with diagnostic functions and set the station number properly. Then turn on the power.
Has the station number setting switch failed?	If the "L ERR." LED starts flashing even though the station number has not been changed during the operation, the possible cause is a hardware failure. Please consult your local Mitsubishi representative.
Is a terminating resistor attached to it even when the CC-Link remote I/O module with diagnostic functions is not used at the end of the network system?	Remove the terminating resistor from the CC-Link remote I/O module with diagnostic functions.
Isn't a terminating resistor attached to it when the CC-Link remote I/O module with diagnostic functions is used at the end of the network system?	Attach the terminating resistor to the CC-Link remote I/O module with diagnostic functions.

7.2 Troubleshooting by Situation

(1) When an external input cannot be read

Check item	Corrective action
Is Initial data processing request flag (RX(n + 1)8) off?	Turn on Initial data processing completion flag (RY(n + 1)8).
Is the setting of a refresh device correct?	Correct the setting so that the setting of the refresh device is the same as that of the sequence program.
Are the red LEDs of X0 to XF flashing?	Correct the input wiring where disconnection (no connection) occurred.
Are the red LEDs of X0 to XF on?	Correct the input wiring where a short-circuit (ground) occurred.

(2) When the data link takes longer time

Check item	Corrective action
Is smaller value set to "Automatic Reconnection Station Count" of the master module?	Set larger value to "Automatic Reconnection Station Count" in Network Parameter of GX Works2 or GX Developer. For details on the settings, refer to the user's manual for the master module used.

(3) When disconnection cannot be detected

Check item	Corrective action
Is Initial data processing request flag (RX(n + 1)8) off?	Turn on Initial data processing completion flag (RY(n + 1)8).
Is the setting of a refresh device correct?	Correct the setting so that the setting of the refresh device is the same as that of the sequence program.
Is Disconnection detection enable/disable setting (RWwm + 0H) correctly set?	Set "Detect disconnection (1)" to the appropriate bit of Disconnection detection enable/disable setting (RWwm + 0H), and turn on Initial data setting request flag (RY(n + 1)9).
Is the value of disconnection (no connection) detection current within the range described in the specification?	Check that the disconnection (no connection) detection current is 0.3mA or lower per point.
Is the condition of the location to detect disconnection (no connection) correct?	Check that the location to detect disconnection (no connection) satisfies the detection condition. ( Page 38, Section 4.4.2 (1))

(4) When a short-circuit cannot be detected

Check item	Corrective action
Is Initial data processing request flag (RX(n + 1)8) off?	Turn on Initial data processing completion flag (RY(n + 1)8).
Is the setting of a refresh device correct?	Correct the setting so that the setting of the refresh device is the same as that of the sequence program.
Is the value of short-circuit (ground) detection current within the range described in the specification?	Check that the short-circuit (ground) detection current is 50mA or higher per point.
Is the condition of the location to detect a short-circuit (ground) correct?	Check that the location to detect a short-circuit (ground) satisfies the detection condition. ( Page 38, Section 4.4.2 (1))

7.3 Troubleshooting When the "ERR." LED of the Master Station Flashes

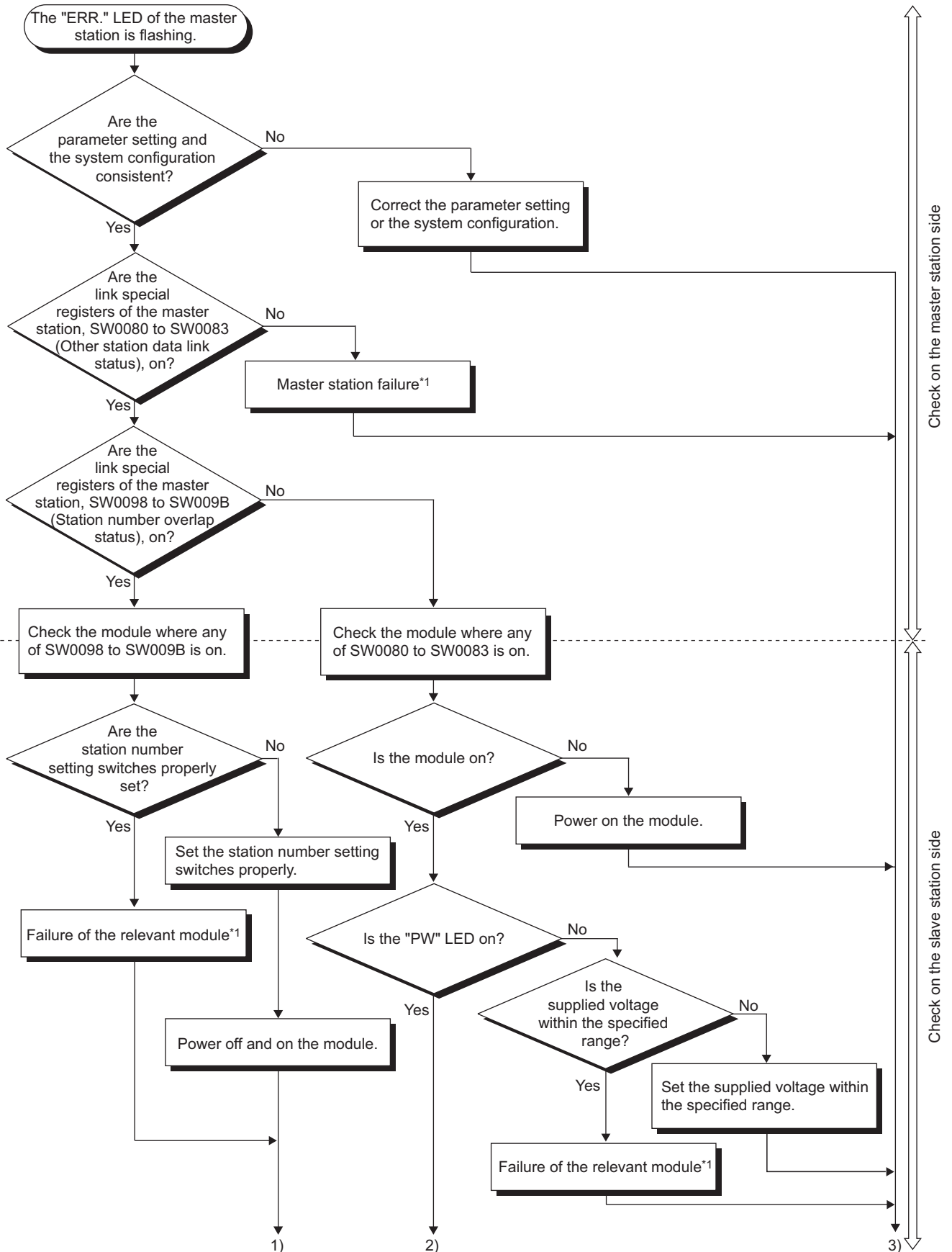

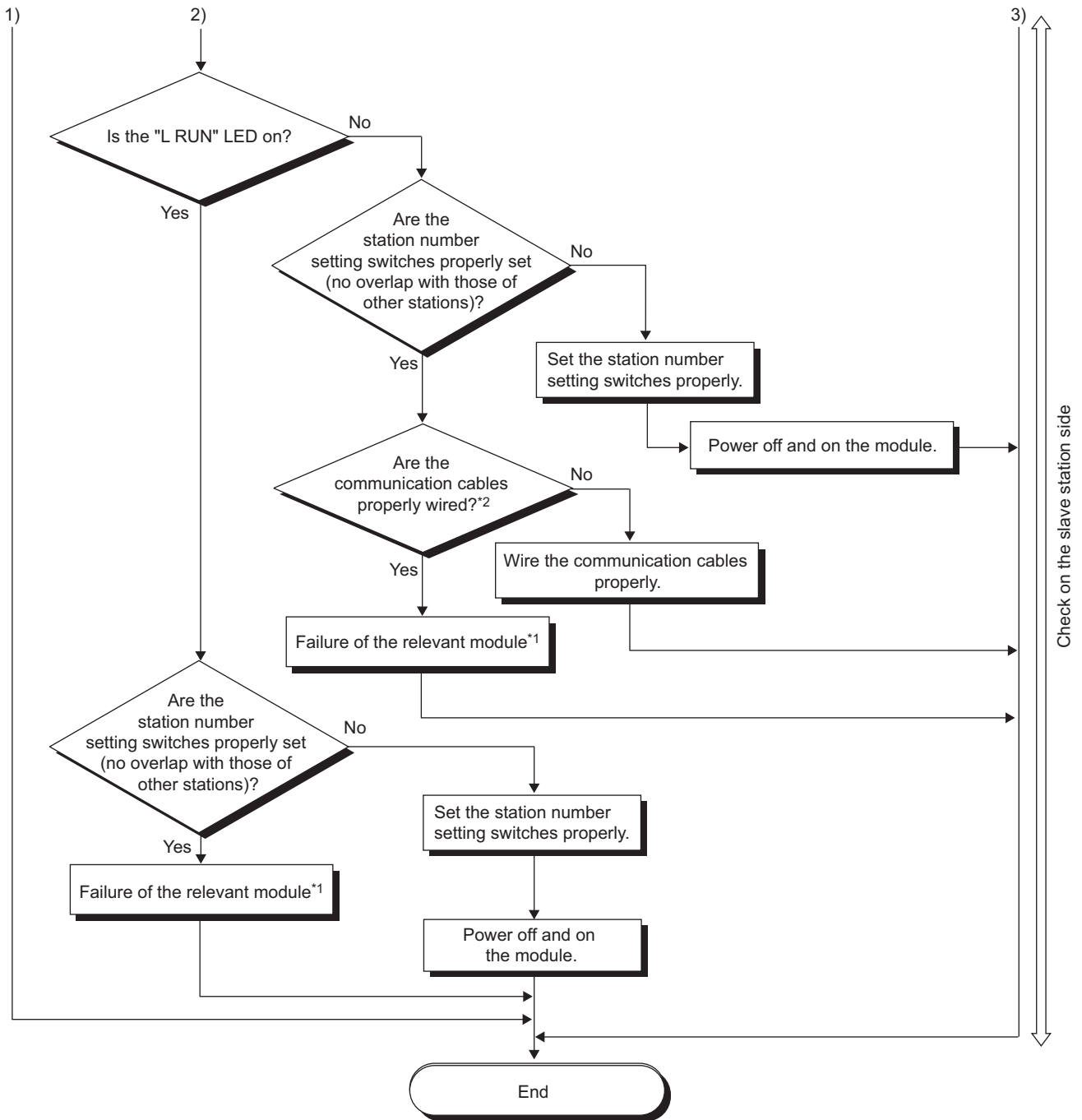

*1 If the master station or the modules have failed, please consult your local Mitsubishi representative.

*2 Check a short-circuit, reverse connection, disconnection, a terminating resistor, FG connection, overall distance, and the distance between stations.

7.4 Examples of Errors for the CC-Link Remote I/O Module with Diagnostic Functions

This section lists errors of the CC-Link remote I/O module with diagnostic functions and the corrective actions.

7.4.1 Errors that may occur in the input circuit and the corrective actions

Examples of errors that may occur in the input circuit and the corrective actions are listed below:

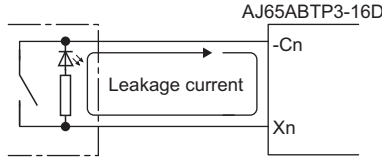
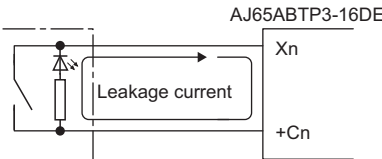
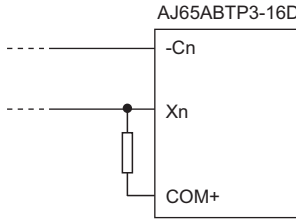
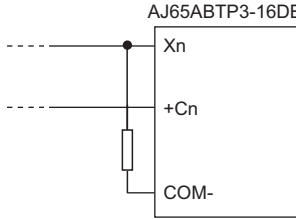
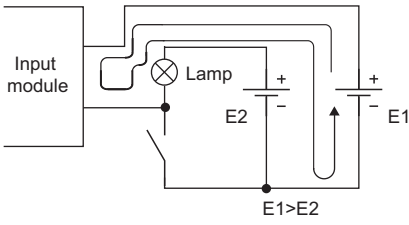
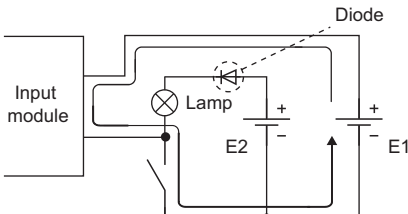
	Error status	Cause	Corrective action
Example 1	Input signals do not turn off.	<p>Activation via the LED indication switch.</p> <ul style="list-style-type: none"> When the AJ65ABTP3-16D is used  <ul style="list-style-type: none"> When the AJ65ABTP3-16DE is used 	<ul style="list-style-type: none"> When the AJ65ABTP3-16D is used Connect an appropriate resistor as shown below so that the voltage between the input terminal (Xn) and the common terminal (-Cn) becomes lower than the value of OFF voltage.  <ul style="list-style-type: none"> When the AJ65ABTP3-16DE is used Connect an appropriate resistor as shown below so that the voltage between the input terminal (Xn) and the common terminal (+Cn) becomes lower than the value of OFF voltage.  <ul style="list-style-type: none"> For a calculation to obtain the resistance value, refer to the following. (☞ Page 121, Section 7.4.1 (1))
Example 2	Input signals do not turn off.	<p>Sneak path due to the use of two power supplies.</p> 	<ul style="list-style-type: none"> Use one power supply only. Connect a diode as shown below to prevent sneak path. 

	Error status	Cause	Corrective action
Example 3	An incorrect signal is input.	Noise is input as a signal.	<ul style="list-style-type: none"> • Do not install the power cables together with the I/O cables to prevent excessive noise. • When using a relay and a conductor (a possible cause of noise) on the same line, take noise reduction measures such as connecting a surge absorber.

(1) Sample calculation for Example 1

When the power, which makes 24VDC output from the common terminal (-Cn/+Cn), is supplied from an external power supply to the CC-Link remote I/O module with diagnostic functions on the condition the switch with LED indicator with maximum leakage current of 3mA is connected

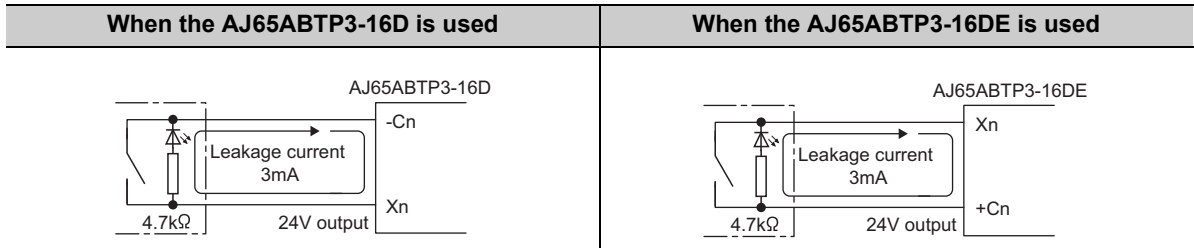

- 1. The circuit does not satisfy the condition that the OFF current of the CC-Link remote I/O module with diagnostic functions is 1.7mA or lower. Therefore, connect a resistor as shown below.**

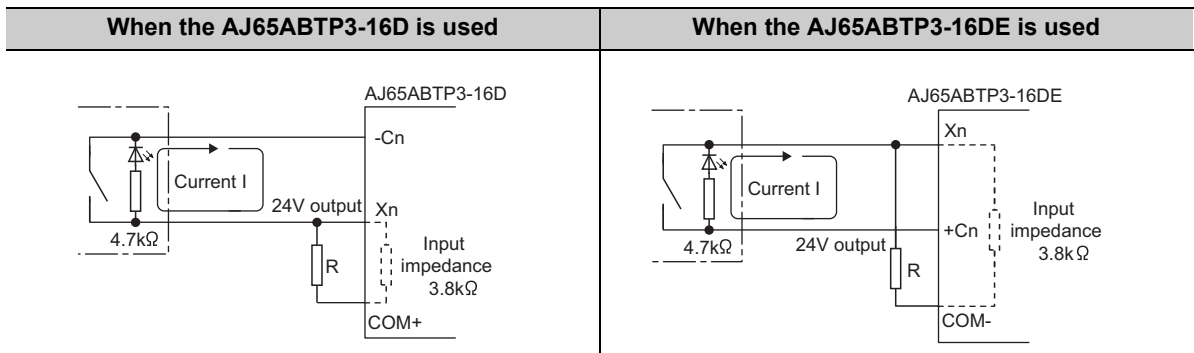

- 2. To satisfy the above condition, connect resistor R through which the current of 1.3mA or higher flows.**

$$I_R = I_Z = Z \text{ (Input impedance)} : R$$

$$R \leq \frac{I_Z}{I_R} \times Z \text{ (Input impedance)} = \frac{1.7}{1.3} \times 3.8 = 5.0 \text{ [k}\Omega\text{]}$$

Assuming that resistance R is 3.9kΩ, the power capacity W of resistor R is:

$$W = (\text{Input voltage})^2 \div R = 28.8^2 \div 3900 = 0.213 \text{ [W]}$$

- 3. Connect a resistor of 3.9kΩ and 2 to 3W to a terminal that may cause an error, because the power capacity of a resistor is selected so that the capacity will be 3 to 5 times greater than the actual power consumption.**
- 4. Also, the OFF voltage when resistor R is connected will be as follows.**

$$\frac{1}{\frac{1}{3.9[\text{k}\Omega]} + \frac{1}{3.8[\text{k}\Omega]}} \times 3[\text{mA}] = 5.77[\text{V}]$$

This satisfies that the OFF voltage of the CC-Link remote I/O module with diagnostic functions is 6V or lower.

APPENDIX

Appendix 1 External Dimensions

This section shows the external dimensions of the CC-Link remote I/O module with diagnostic functions.

(1) AJ65ABTP3-16D

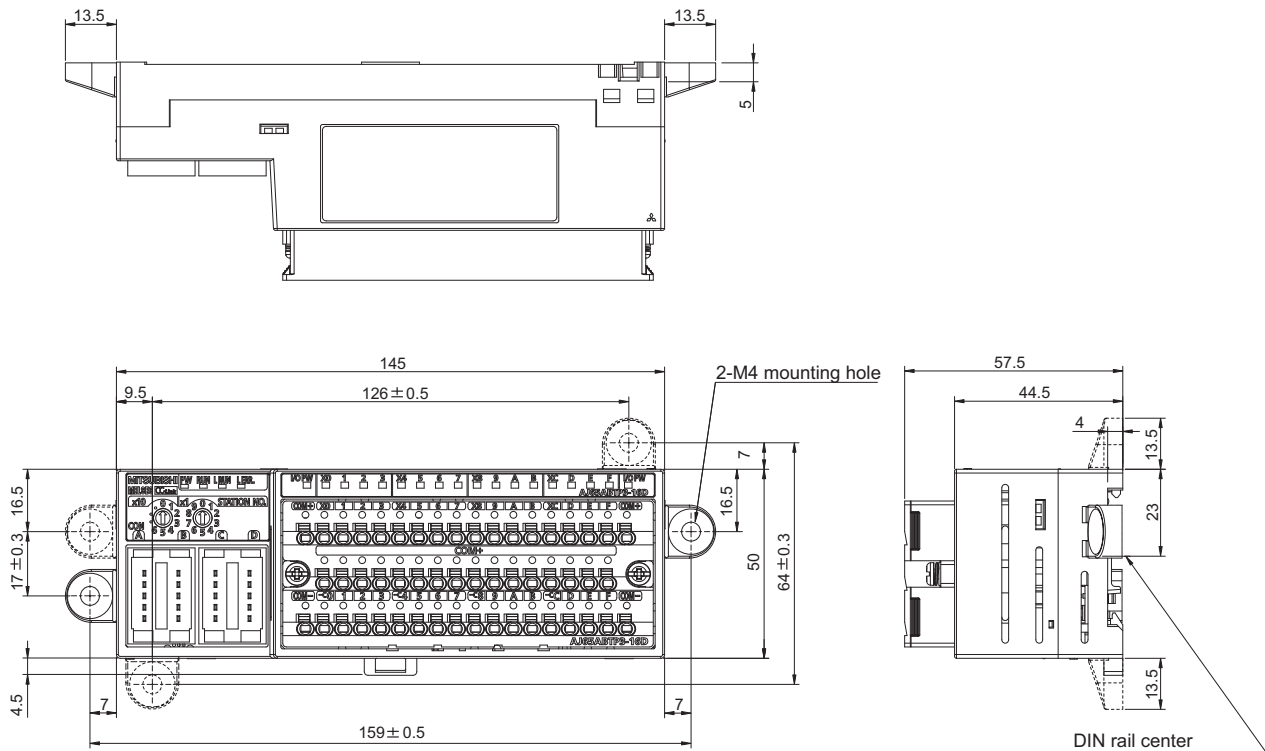

Unit: mm

(2) AJ65ABTP3-16DE

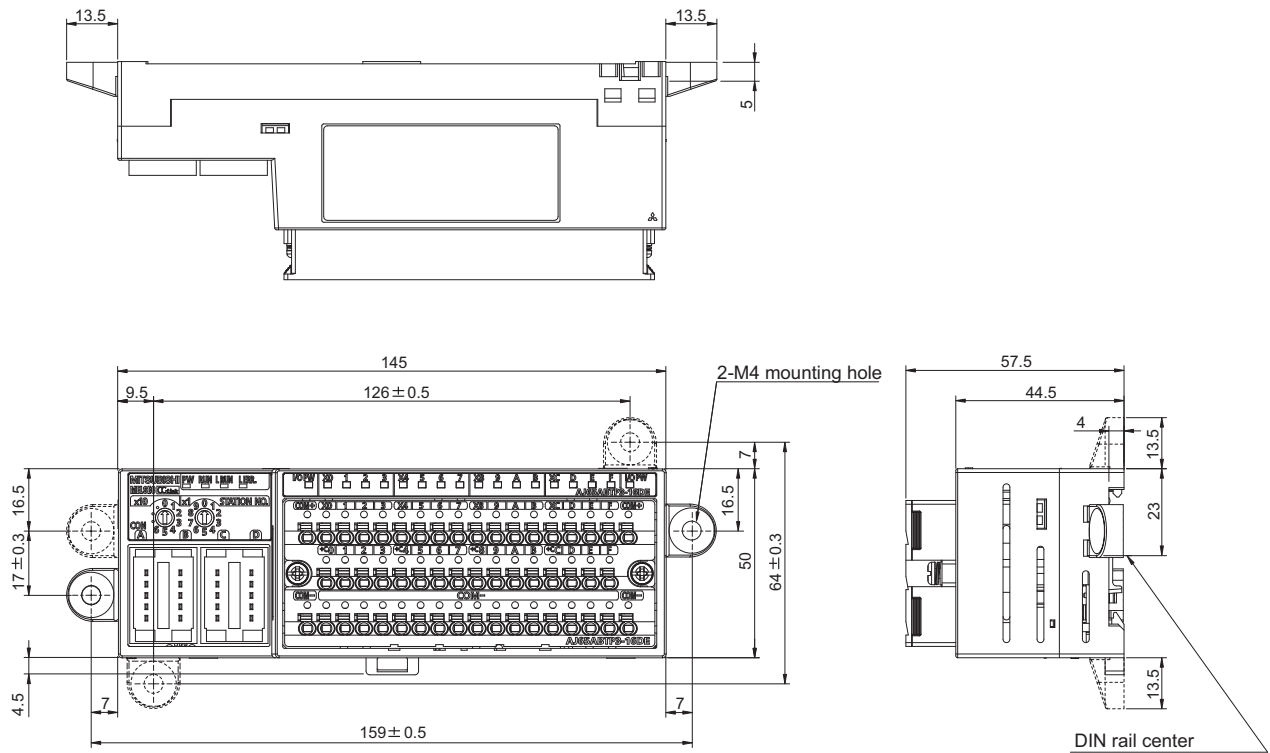

Unit: mm

A

Memo

INDEX

0 to 9

2-piece terminal block fixing screw 23

A

Applicable Systems 20

C

Checking of the power supply status of an external power supply 36,46
COMPLIANCE WITH EMC AND LOW VOLTAGE DIRECTIVES 6
Conditions Used for Program Examples 82
Conduction check hole 23
Connection to the module power supply and data link cables 66
Connection using CC-Link dedicated cables 65

D

Details of remote registers 54
Detection status hold command (RWwm + 1H) 44,54
Detection status hold function 36,44
DIN rail hook 23
Disconnection detection enable/disable setting (RWwm + 0H) 40,54
Disconnection detection status (RWm + 2H) 40,55
Disconnection indication command (RWwm + 2H) 40,54

E

Errors that may occur in the input circuit and the corrective actions 119
External Dimensions 122
External input signals (RXn0 to RXnF) 49

F

Features 14
Function list 36

G

General Specifications 25

H

Handling and Installation Precautions 57
How to Calculate the Current Consumption 34
How to Check for Errors with LED Indications 114
How to Check the Version 21

I

I/O PW LED 22

Identifying the Type 18
Initial data processing completion flag (RY(n + 1)8) 52
Initial data processing request flag (RX(n + 1)8) 49
Initial data setting completion flag (RX(n + 1)9) 51
Initial data setting request flag (RY(n + 1)9) 52
Input diagnostic function 36,37
Input function 36
Installation and removal of the spring clamp terminal block (push-in type) 78
Installation orientation of the module 60
Installation using a DIN rail 61
Installation using screws 62

L

L ERR. LED 22
L RUN LED 22
List of one-touch connector plugs 68
List of remote I/O signals 48
List of remote registers 53

M

Maintenance and Inspection 80
Mounting bracket 23

O

One-touch connector for communication 23
One-touch connector for power supply and FG 23
Open/close button 23
Other station fuse blown status (SW0088 to SW008B) 46
Overall Configuration 19

P

PACKING LIST 13
PART NAMES 22
Performance Specifications 26
Pin 23
Precautions for attaching mounting brackets 63
Procedures Before Operation 56
Program Example When the ACPU/QCPU (A Mode) is Used (Dedicated Instructions) 104
Program Example When the ACPU/QCPU (A Mode) is Used (FROM/TO Instructions) 109
Program Example When the LCPUs is Used 94
Program Example When the QCPU (Q Mode) is Used 84
Program Example When the QnACPU is Used 99
PROGRAMMING 81
Programming Procedure 81
PW LED 22

R

RELEVANT MANUALS 7

Remote READY (RX(n + 1)B)	52
RUN LED	22

S

SAFETY PRECAUTIONS	1
Sensor power supply disconnection (no connection) detection function.	36,40
Sensor power supply short-circuit (ground) detection function.	36,43
Short-circuit detection status (RWrn + 3 _H).	43,55
Short-circuit indication command (RWwm + 3 _H)	43,55
SPECIFICATIONS	25
Spring clamp terminal block (push-in type)	23
Station Number	59
Station number setting switch	22
SYSTEM CONFIGURATION.	19

T

TERMS.	11
Transmission speed auto-tracking function	24,36
TROUBLESHOOTING	114
Troubleshooting by Situation	116
Troubleshooting When the "ERR." LED of the Master Station Flashes	117

W

Wiring precautions	64,77
Wiring procedures for the one-touch connector for communication	69
Wiring procedures for the one-touch connector for power supply and FG	72
Wiring to the External Power Supply and Input Signals	75
Wiring to the Module Power Supply and Data Link Cables	64

X

X0 to XF	22
--------------------	----

REVISIONS

*The manual number is given on the bottom left of the back cover.

Print date	*Manual number	Revision
September 2011	SH(NA)-080998ENG-A	First edition
December 2011	SH(NA)-080998ENG-B	Descriptions regarding the AJ65ABTP3-16D are added.
June 2012	SH(NA)-080998ENG-C	<div style="border: 1px solid black; padding: 2px;">Partial correction</div> COMPLIANCE WITH EMC AND LOW VOLTAGE DIRECTIVES, RELEVANT MANUALS, Chapter 3, Section 2.1, 4.1, 5.5.2, 5.5.3, 5.5.4, 7.2, 7.3
January 2014	SH(NA)-080998ENG-D	<div style="border: 1px solid black; padding: 2px;">Partial correction</div> RELEVANT MANUALS, TERMS, Section 4.2.1, 4.2.2, 5.4.3, 6.3, 6.4, 7.1, 7.3, 7.4.1
October 2014	SH(NA)-080998ENG-E	<div style="border: 1px solid black; padding: 2px;">Partial correction</div> RELEVANT MANUALS, TERMS, Section 2.2, 2.3, 5.5.2 <div style="border: 1px solid black; padding: 2px;">Addition</div> GENERIC TERMS AND ABBREVIATIONS, Section 2.4

Japanese manual version SH-080997-G

This manual confers no industrial property rights or any rights of any other kind, nor does it confer any patent licenses. Mitsubishi Electric Corporation cannot be held responsible for any problems involving industrial property rights which may occur as a result of using the contents noted in this manual.

WARRANTY

Please confirm the following product warranty details before using this product.

1. Gratis Warranty Term and Gratis Warranty Range

If any faults or defects (hereinafter "Failure") found to be the responsibility of Mitsubishi occurs during use of the product within the gratis warranty term, the product shall be repaired at no cost via the sales representative or Mitsubishi Service Company.

However, if repairs are required onsite at domestic or overseas location, expenses to send an engineer will be solely at the customer's discretion. Mitsubishi shall not be held responsible for any re-commissioning, maintenance, or testing on-site that involves replacement of the failed module.

[Gratis Warranty Term]

The gratis warranty term of the product shall be for one year after the date of purchase or delivery to a designated place.

Note that after manufacture and shipment from Mitsubishi, the maximum distribution period shall be six (6) months, and the longest gratis warranty term after manufacturing shall be eighteen (18) months. The gratis warranty term of repair parts shall not exceed the gratis warranty term before repairs.

[Gratis Warranty Range]

- (1) The range shall be limited to normal use within the usage state, usage methods and usage environment, etc., which follow the conditions and precautions, etc., given in the instruction manual, user's manual and caution labels on the product.
- (2) Even within the gratis warranty term, repairs shall be charged for in the following cases.
 1. Failure occurring from inappropriate storage or handling, carelessness or negligence by the user. Failure caused by the user's hardware or software design.
 2. Failure caused by unapproved modifications, etc., to the product by the user.
 3. When the Mitsubishi product is assembled into a user's device, Failure that could have been avoided if functions or structures, judged as necessary in the legal safety measures the user's device is subject to or as necessary by industry standards, had been provided.
 4. Failure that could have been avoided if consumable parts (battery, backlight, fuse, etc.) designated in the instruction manual had been correctly serviced or replaced.
 5. Failure caused by external irresistible forces such as fires or abnormal voltages, and Failure caused by force majeure such as earthquakes, lightning, wind and water damage.
 6. Failure caused by reasons unpredictable by scientific technology standards at time of shipment from Mitsubishi.
 7. Any other failure found not to be the responsibility of Mitsubishi or that admitted not to be so by the user.

2. Onerous repair term after discontinuation of production

- (1) Mitsubishi shall accept onerous product repairs for seven (7) years after production of the product is discontinued.
Discontinuation of production shall be notified with Mitsubishi Technical Bulletins, etc.
- (2) Product supply (including repair parts) is not available after production is discontinued.

3. Overseas service

Overseas, repairs shall be accepted by Mitsubishi's local overseas FA Center. Note that the repair conditions at each FA Center may differ.

4. Exclusion of loss in opportunity and secondary loss from warranty liability

Regardless of the gratis warranty term, Mitsubishi shall not be liable for compensation of damages caused by any cause found not to be the responsibility of Mitsubishi, loss in opportunity, lost profits incurred to the user by Failures of Mitsubishi products, special damages and secondary damages whether foreseeable or not, compensation for accidents, and compensation for damages to products other than Mitsubishi products, replacement by the user, maintenance of on-site equipment, start-up test run and other tasks.

5. Changes in product specifications

The specifications given in the catalogs, manuals or technical documents are subject to change without prior notice.

SH(NA)-080998ENG-E(1410)MEE

MODEL: CC-LINK-DF-I/O-U-E

MODEL CODE: 13JZ63

MITSUBISHI ELECTRIC CORPORATION

HEAD OFFICE : TOKYO BUILDING, 2-7-3 MARUNOUCHI, CHIYODA-KU, TOKYO 100-8310, JAPAN
NAGOYA WORKS : 1-14, YADA-MINAMI 5-CHOME, HIGASHI-KU, NAGOYA, JAPAN

When exported from Japan, this manual does not require application to the
Ministry of Economy, Trade and Industry for service transaction permission.

Specifications subject to change without notice.