

Mounting Guide of Q6DIN1A: Adaptors (with Vibration-proofing Bracket Set) for Q Base Unit DIN Rail Mounting BCN-P5649-B

This product is the set of adapters for DIN rail mounting included with vibration-proofing brackets to improve resistance to vibration when mounting Q base unit to the DIN rail.

1. Component

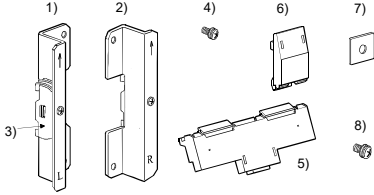

Part name	Quantity	Part name	Quantity
1) Mounting bracket L	1	5) Adaptor (large)	2
2) Mounting bracket R	1	6) Adaptor (small)	4
3) Stopper*	2	7) Square washer	3
4) Module mounting screw (M4X10)	4	8) Mounting screw (M5X10)	3

* Attached to mounting brackets L and R.

2. Applicable Base Unit and Its Mounting Dimension

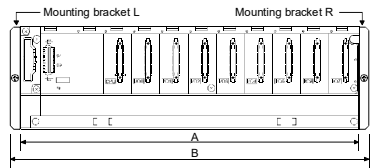

Applicable base unit	A	B
Q00JCPU	245mm (9.65inch)	273mm (10.74inch)
Q33B	189mm (7.44inch)	217mm (8.54inch)
Q35B	245mm (9.65inch)	273mm (10.74inch)
Q38B	328mm (12.91inch)	356mm (14.02inch)
Q312B	439mm (17.28inch)	467mm (18.39inch)
Q32SB	114mm (4.49inch)	149mm (5.87inch)
Q33SB	142mm (5.59inch)	177mm (6.97inch)
Q35SB	197.5mm (7.78inch)	233mm (9.17inch)
Q38RB	439mm (17.28inch)	467mm (18.39inch)
Q52B	106mm (4.16inch)	132mm (5.20inch)
Q55B, Q63B	189mm (7.44inch)	215mm (8.46inch)
Q65B	245mm (9.65inch)	271mm (10.67inch)
Q68B	328mm (12.91inch)	354mm (13.94inch)
Q612B, Q68RB, Q65WRB	439mm (17.28inch)	465mm (18.31inch)

3. Applicable DIN rail types

TH35-7.5Fe
TH35-7.5Al
TH35-15Fe

4. Installation method

(1) Installation method of adaptor

The way to install the adaptors for mounting a DIN rail to the base unit is given below.

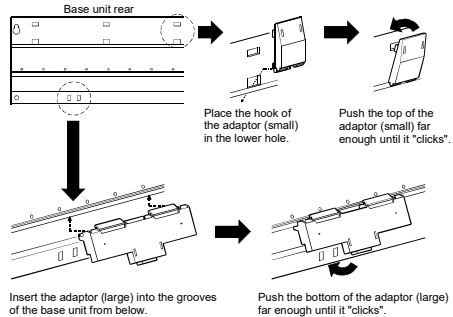

(2) DIN rail mounting screw intervals

When using a DIN rail, DIN rail mounting screws (user prepared) should be tightened at intervals of 200 mm (7.88 inch) or less in order to ensure that the rail has sufficient strength.

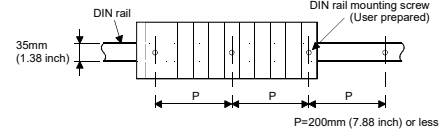

<When Q38B, Q312B, Q38RB, Q68B, Q612B, Q68RB or Q65WRB is used>
In Position A (base unit bottom), screw the DIN rail in three places using the included mounting screws and square washers.

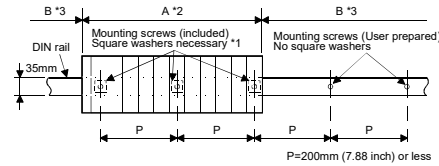

<When Q00JCPU, Q33B, Q35B, Q32SB, Q33SB, Q35SB, Q52B, Q55B, Q63B, or Q65B is used>
In Position A (base unit bottom), screw the DIN rail in two places using the included mounting screws and square washers.

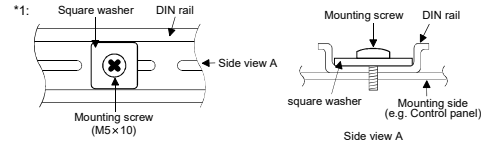
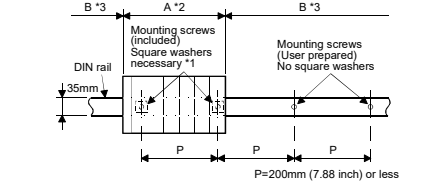

- *1: In Position A (base unit bottom), screw the DIN rail to a control panel using the included mounting screws and square washers.
- *2: In Position B (where the base unit is not installed), included mounting screws and square washers are not used. Screw the DIN rail with user-prepared mounting screws.

POINT

- Use only one washer for each mounting screw. Use the included square washers only. If two or more washers are used together for one mounting screw, the screw may interfere with the base unit.
- Be sure to align the square washer sides with the DIN rail.
- Use the DIN rail that accepts M5 size screws.

(3) Mounting procedure of stoppers and mounting brackets

The following shows the procedure for mounting the stoppers and mounting brackets to the base unit.

- Loosen a locking screw of a mounting bracket. (Be careful not to let square nut come off.)
- Setting the mounting bracket in the direction that L (left) / R (right) printing is not upside down, hitch the lower hook to the bottom of the DIN rail. Then, hitch the upper hook of the stopper to the top of the DIN rail. Shift the mounting bracket downward and check that it is securely fixed to the DIN rail.
- Slide the mounting bracket L to the base unit mounting position and fix the stopper and the DIN rail using the locking screw. (Tightening torque 1.00 to 1.35N·m)
- Temporary set the module mounting screw to the upper hole of the mounting bracket L.
- Mount the base unit to the DIN rail with the left/upper side pear-shaped hole of the base unit placing onto the module mounting screw temporary set. (Hitch the hooks of the adaptor (large) and adaptor (small) to the DIN rail securely when mounting the base unit to the DIN rail.)
- Fix the base unit and the mounting bracket L using the module mounting screw. (Tightening torque 1.00 to 1.35 N·m)
- Fix the base unit and the mounting bracket L using the module mounting screw. (Tightening torque 1.00 to 1.35 N·m) Then, fix the stopper and the mounting bracket R using the locking screw of the stopper. (Tightening torque 1.00 to 1.35N·m)
- Make sure that both mounting bracket L/R and their respective stoppers are securely fixed to the base unit and the DIN rail.

Completed

5. Precaution

- To facilitate the mounting operation of Q6DIN1A mounting brackets, make room (50mm (1.97 inch) or more) between the right/left edge of the base unit and the structural devices/parts.