



# VECTOR INVERTER

## FR-V500

### INSTRUCTION MANUAL (Detailed)

---

HIGH PRECISION & FAST  
RESPONSE VECTOR INVERTER

---

# FR-V520-1.5K to 55K

# FR-V540-1.5K to 55K

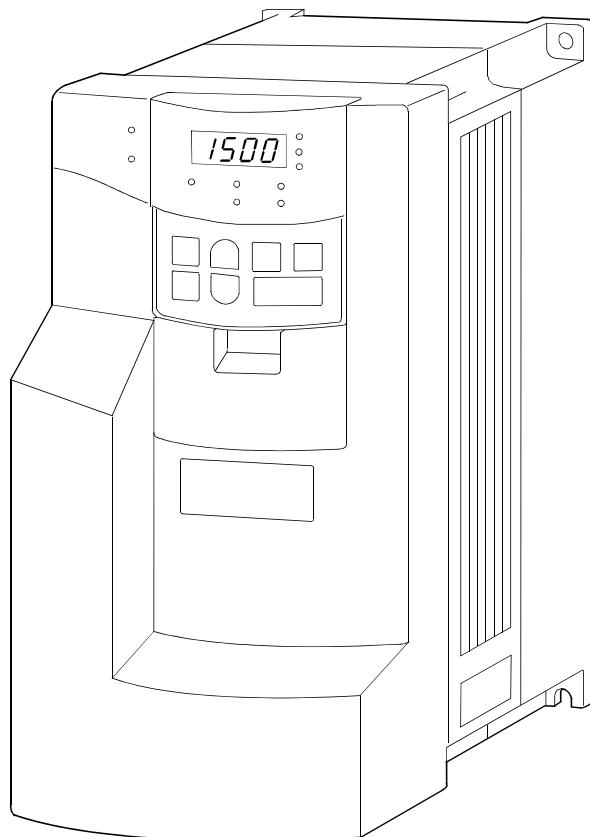

WIRING

1

VECTOR  
CONTROL

2

PARAMETERS

3

SPECIFICATIONS

4

Thank you for choosing this Mitsubishi vector inverter. This Instruction Manual (detailed) provides instructions for advanced use of the FR-V500 series inverters. Incorrect handling might cause an unexpected fault. Before using the inverter, always read this Instruction Manual and the Instruction Manual (basic) [IB-0600064] packed with the product carefully to use the equipment to its optimum performance.

**This section is specifically about safety matters**

Do not attempt to install, operate, maintain or inspect the inverter until you have read through the Instruction Manual (basic) and appended documents carefully and can use the equipment correctly. Do not use the inverter until you have a full knowledge of the equipment, safety information and instructions. In this Instruction Manual, the safety instruction levels are classified into "WARNING" and "CAUTION".



**WARNING**

Assumes that incorrect handling may cause hazardous conditions, resulting in death or severe injury.



**CAUTION**

Assumes that incorrect handling may cause hazardous conditions, resulting in medium or slight injury, or may cause physical damage only.

Note that even the **CAUTION** level may lead to a serious consequence according to conditions. Please follow the instructions of both levels because they are important to personnel safety.

**1. Electric Shock Prevention**



**WARNING**

- While power is on or when the inverter is running, do not open the front cover. You may get an electric shock.
- Do not run the inverter with the front cover or wiring cover removed. Otherwise, you may access the exposed high-voltage terminals or the charging part of the circuitry and get an electric shock.
- Even if power is off, do not remove the front cover except for wiring or periodic inspection. You may access the charged inverter circuits and get an electric shock.
- Before starting wiring or inspection, check to make sure that the inverter power indicator lamp is off, wait for at least 10 minutes after the power supply has been switched off, and check that there are no residual voltage using a tester or the like. The capacitor is charged with high voltage for some time after power off and it is dangerous.
- This inverter must be earthed (grounded). Earthing (Grounding) must conform to the requirements of national and local safety regulations and electrical codes. (NEC section 250, IEC 536 class 1 and other applicable standards).
- Any person who is involved in wiring or inspection of this equipment should be fully competent to do the work.
- Always install the inverter before wiring. Otherwise, you may get an electric shock or be injured.
- Perform setting dial and key operations with dry hands to prevent an electric shock.
- Do not subject the cables to scratches, excessive stress, heavy loads or pinching. Otherwise, you may get an electric shock.
- Do not change the cooling fan while power is on. It is dangerous to change the cooling fan while power is on.

**2. Fire Prevention**



**CAUTION**

- Install the inverter on an incombustible wall without holes, etc. Mounting it to or near combustible material can cause a fire.
- If the inverter has become faulty, switch off the inverter power. A continuous flow of large current could cause a fire.
- When a brake resistor is used, use an alarm signal to switch power off. Otherwise, the brake resistor will overheat abnormally due to a brake transistor or other fault, resulting in a fire.
- Do not connect a resistor directly to the DC terminals P, N. This could cause a fire.

**3. Injury Prevention**



**CAUTION**

- Apply only the voltage specified in the instruction manual to each terminal to prevent damage etc.
- Ensure that the cables are connected to the correct terminals. Otherwise damage etc. may occur.
- Always make sure that polarity is correct to prevent damage etc.
- While power is on and for some time after power-off, do not touch the inverter or brake resistor as they are hot and you may get burnt.

**4. Additional Instructions**

Also note the following points to prevent an accidental failure, injury, electric shock, etc.

**1) Transportation and installation**



**CAUTION**

- When carrying products, use correct lifting gear to prevent injury.
- Do not stack the inverter boxes higher than the number recommended.
- Ensure that installation position and material can withstand the weight of the inverter. Install according to the information in the instruction manual.
- Do not operate if the inverter is damaged or has parts missing.
- When carrying the inverter, do not hold it by the front cover; it may fall off or fail.
- Do not stand or rest heavy objects on the inverter.
- Check the inverter mounting orientation is correct.
- Prevent screws, wire fragments, other conductive bodies, oil or other flammable substances from entering the inverter.
- Do not drop the inverter, or subject it to impact
- Use the inverter under the following environmental conditions:

Environment	Ambient temperature	-10°C to +50°C (non-freezing)
	Ambient humidity	90%RH or less (non-condensing)
	Storage temperature	-20°C to +65°C*
	Ambience	Indoors (free from corrosive gas, flammable gas, oil mist, dust and dirt)
	Altitude, vibration	Maximum 1000m above sea level for standard operation. After that derate by 3% for every extra 500m up to 2500m (91%). 5.9m/s <sup>2</sup> or less

\*Temperature applicable for a short time, e.g. in transit.

## 2) Wiring

### CAUTION

- Do not fit capacitive equipment such as power factor correction capacitor, surge suppressor or radio noise filter (option FR-B1F) to the inverter output side.
- The connection orientation of the output cables (terminals U, V, W) to the motor will affect the direction of rotation of the motor.

## 3) Trial run

### CAUTION

- Check all parameters, and ensure that the machine will not be damaged by a sudden start-up.

## 4) Operation

### WARNING

- When you have chosen the retry function, stay away from the equipment as it will restart suddenly after an alarm stop.
- Since the [STOP] key is valid only when functions are set (refer to page 115) provide a circuit and switch separately to make an emergency stop (power off, mechanical brake operation for emergency stop, etc).
- Make sure that the start signal is off before resetting the inverter alarm. A failure to do so may restart the motor suddenly.
- The load used should be a three-phase induction motor only. Connection of any other electrical equipment to the inverter output may damage the equipment.
- Do not modify the equipment.
- Do not perform parts removal which is not instructed in this manual. Doing so may lead to fault or damage of the inverter.

### CAUTION

- The electronic thermal relay function does not guarantee protection of the motor from overheating.
- Do not use a magnetic contactor on the inverter input for frequent starting/stopping of the inverter.
- Use a noise filter to reduce the effect of electromagnetic interference. Otherwise nearby electronic equipment may be affected.
- Take measures to suppress harmonics. Otherwise power supply harmonics from the inverter may heat/damage the power capacitor and generator.
- When a 400V class motor is inverter-driven, please use an insulation-enhanced motor or measures taken to suppress surge voltages. Surge voltages attributable to the wiring constants may occur at the motor terminals, deteriorating the insulation of the motor.
- When parameter clear or all clear is performed, each parameter returns to the factory setting. Each parameter returns to the factory setting.
- The inverter can be easily set for high-speed operation. Before changing its setting, fully examine the performances of the motor and machine.
- In addition to the inverter's holding function, install a holding device to ensure safety.
- Before running an inverter which had been stored for a long period, always perform inspection and test operation. In addition to the inverter's holding function, install a holding device to ensure safety.

## 5) Emergency stop

### CAUTION

- Provide a safety backup such as an emergency brake which will prevent the machine and equipment from hazardous conditions if the inverter fails.
- When the breaker on the inverter input side trips, check for the wiring fault (short circuit), damage to internal parts of the inverter, etc. Identify the cause of the trip, then remove the cause and power on the breaker.
- When the protective function is activated, take the appropriate corrective action, then reset the inverter, and resume operation.

## 6) Maintenance, inspection and parts replacement

### CAUTION

- Do not carry out a megger (insulation resistance) test on the control circuit of the inverter.

## 7) Disposing of the inverter

### CAUTION

- Treat as industrial waste.

## 8) General instructions

Many of the diagrams and drawings in this Instruction Manual (basic) show the inverter without a cover, or partially open. Never operate the inverter in this manner. Always replace the cover and follow this Instruction Manual (basic) when operating the inverter.

# CONTENTS

<b>1</b>	<b>WIRING</b>	<b>1</b>
<b>1.1</b>	<b>Internal block diagram</b>	<b>2</b>
<b>1.2</b>	<b>Main circuit terminal specifications</b>	<b>3</b>
<b>1.3</b>	<b>Connection of stand-alone option units</b>	<b>4</b>
1.3.1	Connection of the dedicated external brake resistor (FR-ABR)	4
1.3.2	Connection of the brake unit (FR-BU)	5
1.3.3	Connection of the brake unit (BU type)	6
1.3.4	Connection of the high power factor converter (FR-HC)	6
1.3.5	Connection of the power regeneration common converter (FR-CV)	7
1.3.6	Connection of the DC reactor (FR-HEL/BEL)	7
<b>1.4</b>	<b>Control circuit terminal specifications</b>	<b>8</b>
1.4.1	Connecting the control circuit to a power supply separately from the main circuit	10
<b>1.5</b>	<b>Precautions for use of the vector inverter</b>	<b>11</b>
<b>1.6</b>	<b>Others</b>	<b>12</b>
1.6.1	Leakage currents and countermeasures	12
1.6.2	Power off and magnetic contactor (MC)	14
1.6.3	Installation of reactor	15
1.6.4	Notes on earthing (grounding)	16
1.6.5	Inverter-generated noises and their reduction techniques	17
1.6.6	Power supply harmonics	19
1.6.7	Harmonic suppression guidelines	20
1.6.8	Inverter-driven 400V class motor	22
1.6.9	Using the PU connector for computer link	23
<b>1.7</b>	<b>Input terminals</b>	<b>26</b>
1.7.1	Run (start) and stop (STF, STR, STOP)	26
1.7.2	External thermal relay input (OH)	27
1.7.3	Speed setting potentiometer connection (10E, 2 (1), 5)	27
1.7.4	Torque setting input signal and motor-generated torque (terminals 3, 5)	28
1.7.5	Meter connection method and adjustment (DA1, DA2)	28
1.7.6	Common terminals (SD, 5, SE)	29
1.7.7	Signal inputs by contact-less switches	29
<b>1.8</b>	<b>How to use the input signals (assigned terminals DI1 to DI4, STR) (Pr. 180 to Pr. 183, Pr. 187)</b>	<b>30</b>
1.8.1	Multi-speed setting (RL, RM, RH, REX signals): Pr. 180 to Pr. 183, Pr. 187 setting "0, 1, 2, 8" Remote setting (RL, RM, RH signals): Pr. 180 to Pr. 183, Pr. 187 setting "0, 1, 2"	30
1.8.2	Second function selection/second motor switchover (RT signal) : Pr. 180 to Pr. 183, Pr. 187 setting "3"	30
1.8.3	Jog operation (jog signal): Pr. 180 to Pr. 183, Pr. 187 setting "5"	30
1.8.4	Third function selection (X9 signal): Pr. 180 to Pr. 183, Pr. 187 setting "9"	31
1.8.5	FR-HC, FR-CV connection (X10 signal): Pr. 180 to Pr. 183, Pr. 187 setting "10"	31
1.8.6	PU operation external interlock signal (X12 signal): Pr. 180 to Pr. 183, Pr. 187 setting "12"	31
1.8.7	PID control enable terminal: Pr. 180 to Pr. 183, Pr. 187 setting "14"	31
1.8.8	Brake sequence opening signal (BRI signal): Pr. 180 to Pr. 183, Pr. 187 setting "15"	31
1.8.9	PU operation/external operation switchover: Pr. 180 to Pr. 183, Pr. 187 setting "16"	31
1.8.10	S-pattern acceleration/deceleration C switchover terminal (X20 signal) : Pr. 180 to Pr. 183, Pr. 187 setting "20"	31
1.8.11	Orientation command (X22 signal): Pr. 180 to Pr. 183, Pr. 187 setting "22"	32
1.8.12	Pre-excitation/servo on (LX signal): Pr. 180 to Pr. 183, Pr. 187 setting "23"	32

1.8.13	Output stop (MRS signal): Pr. 180 to Pr. 183, Pr. 187 setting "24" .....	32
1.8.14	Start self-holding selection (STOP signal): Pr. 180 to Pr. 183, Pr. 187 setting "25" .....	32
1.8.15	Control mode changing (MC signal): Pr. 180 to Pr. 183, Pr. 187 setting "26" .....	33
1.8.16	Torque limit selection (TL signal): Pr. 180 to Pr. 183, Pr. 187 setting "27" .....	33
1.8.17	Start time tuning (X28 signal): Pr. 180 to Pr. 183, Pr. 187 setting "28" .....	33
1.8.18	Torque bias selection 1 (X42 signal): Pr. 180 to Pr. 183, Pr. 187 setting "42" Torque bias selection 2 (X43 signal): Pr. 180 to Pr. 183, Pr. 187 setting "43" .....	33
1.8.19	P control selection (P/PI control switchover) (X44 signal): Pr. 180 to Pr. 183, Pr. 187 setting "44" .....	34
<b>1.9</b>	<b>How to use the output signals (assigned terminals DO1 to DO3, ABC) (Pr. 190 to Pr. 192, Pr. 195) .....</b>	<b>35</b>
<b>1.10</b>	<b>Design information to be checked .....</b>	<b>37</b>
<b>1.11</b>	<b>Using the second motor .....</b>	<b>38</b>
1.11.1	Wiring diagram (second motor) .....	38
1.11.2	Second motor setting parameters .....	38
<b>1.12</b>	<b>Using the conventional motor and other motors .....</b>	<b>39</b>
1.12.1	Conventional motor (SF-VR, SF-JR with encoder) .....	39
1.12.2	Precautions for and wiring of the motor with encoder (SF-JR with encoder) .....	40

## **2 VECTOR CONTROL**

**41**

<b>2.1</b>	<b>What is vector control? .....</b>	<b>42</b>
<b>2.2</b>	<b>Speed control .....</b>	<b>44</b>
2.2.1	Outline of speed control .....	44
2.2.2	Easy gain tuning function block diagram .....	44
<b>2.3</b>	<b>Fine adjustment of gains for speed control .....</b>	<b>45</b>
2.3.1	Control block diagram .....	45
2.3.2	Concept of adjustment of manual input speed control gains .....	46
2.3.3	Speed control gain adjustment procedure (Pr. 820, Pr. 821) .....	46
2.3.4	Troubleshooting .....	47
2.3.5	Speed feed forward control, model adaptive speed control (Pr. 828, Pr. 877 to Pr. 881) .....	49
<b>2.4</b>	<b>Torque control .....</b>	<b>51</b>
2.4.1	Outline of torque control .....	51
<b>2.5</b>	<b>Fine adjustment for torque control .....</b>	<b>52</b>
2.5.1	Control block diagram .....	52
<b>2.6</b>	<b>Gain adjustment for torque control .....</b>	<b>53</b>
2.6.1	Concept of torque control gains .....	53
2.6.2	Gain adjustment procedure .....	53
2.6.3	Troubleshooting .....	54
<b>2.7</b>	<b>Position control (Pr. 419 to Pr. 430, Pr. 464 to Pr. 494) .....</b>	<b>55</b>
2.7.1	Connection diagram .....	55
2.7.2	Position control step .....	56
2.7.3	Control block diagram .....	57
2.7.4	Parameter .....	57
2.7.5	Conditional position feed function by contact input (Pr. 419 = 0) .....	59
2.7.6	Setting the electronic gear .....	60
2.7.7	In-position width (Pr. 426) .....	62
2.7.8	Excessive level error (Pr. 427) .....	62

2.7.9	Pulse monitor selection (Pr. 430) .....	62
2.7.10	Concept of position control gains .....	62
2.7.11	Troubleshooting.....	63
2.7.12	Position control is not exercised normally .....	64

### **3 PARAMETERS 65**

---

<b>3.1</b>	<b>Parameter list .....</b>	<b>66</b>
<b>3.2</b>	<b>At-a-glance guide to functions .....</b>	<b>73</b>
<b>3.3</b>	<b>Basic functions (Pr. 0 to Pr. 9).....</b>	<b>76</b>
3.3.1	Torque boost (Pr. 0) .....	76
3.3.2	Maximum and minimum speed settings (Pr. 1 , Pr. 2) .....	76
3.3.3	Base frequency, base frequency voltage (Pr. 3, Pr. 19).....	77
3.3.4	Multi-speed operation (Pr. 4 to Pr. 6, Pr. 24 to Pr. 27, Pr. 232 to Pr. 239).....	77
3.3.5	Acceleration and deceleration time (Pr. 7, Pr. 8, Pr. 20, Pr. 21, Pr. 44, Pr. 45, Pr. 110, Pr. 111) ...	78
3.3.6	Motor overheat protection (Pr. 9, Pr. 452, Pr. 876 ) .....	80
<b>3.4</b>	<b>Standard operation functions (Pr. 10 to Pr. 16) .....</b>	<b>82</b>
3.4.1	DC injection brake operation (Pr. 10, Pr.11, Pr. 12, Pr.802) .....	82
3.4.2	Starting speed (Pr. 13) .....	84
3.4.3	Jog operation (Pr. 15, Pr. 16).....	85
<b>3.5</b>	<b>Operation selection functions 1 (Pr. 17 to Pr. 37).....</b>	<b>86</b>
3.5.1	Inverter output stop (MRS) (Pr. 17).....	86
3.5.2	Torque limit (Pr. 22, Pr. 803, Pr. 810 to Pr. 817).....	87
3.5.3	RH, RM, RL signal input compensation (Pr. 28) .....	88
3.5.4	S-pattern acceleration/deceleration curve (Pr. 29, Pr. 140 to Pr. 143, Pr. 380 to Pr. 383) .....	89
3.5.5	Regenerative brake duty (Pr. 30, Pr. 70).....	92
3.5.6	Speed jump (Pr. 31 to Pr. 36).....	93
3.5.7	Speed display (Pr. 37, Pr. 144, Pr. 505 ).....	93
<b>3.6</b>	<b>Output terminal functions (Pr. 41 to Pr. 50).....</b>	<b>95</b>
3.6.1	Up-to-speed sensitivity (Pr. 41).....	95
3.6.2	Speed detection (Pr. 42, Pr. 43, Pr. 50, Pr. 116).....	95
<b>3.7</b>	<b>Display functions 1 (Pr. 52 to Pr. 56).....</b>	<b>97</b>
3.7.1	Monitor display/DA1, DA2 terminal function selection (Pr. 52 to Pr. 54, Pr. 158) .....	97
3.7.2	Monitoring reference (Pr. 55, Pr. 56, Pr. 866) .....	100
<b>3.8</b>	<b>Automatic restart (Pr. 57, Pr. 58) .....</b>	<b>101</b>
3.8.1	Automatic restart after instantaneous power failure (Pr. 57, Pr. 58, Pr. 162 to Pr. 165) .....	101
<b>3.9</b>	<b>Additional functions (Pr. 59) .....</b>	<b>103</b>
3.9.1	Remote setting function selection (Pr. 59 ) .....	103
<b>3.10</b>	<b>Brake sequence (Pr. 60, Pr. 278 to Pr. 285) .....</b>	<b>106</b>
3.10.1	Brake sequence function (Pr. 60, Pr. 278 to Pr. 285).....	106
<b>3.11</b>	<b>Operation selection function 2 (Pr. 65 to Pr. 79).....</b>	<b>109</b>
3.11.1	Retry function (Pr. 65, Pr. 67 to Pr. 69).....	109
3.11.2	Applied motor (Pr. 71, Pr. 450).....	111
3.11.3	PWM carrier frequency selection (Pr. 72, Pr. 240).....	112
3.11.4	Speed setting signal on/off selection (Pr. 73).....	113
3.11.5	Reset selection/disconnected PU detection/PU stop selection (Pr. 75).....	115
3.11.6	Parameter write disable selection (Pr. 77) .....	116

3.11.7	Reverse rotation prevention selection (Pr. 78 )	117
3.11.8	Operation mode selection (Pr. 79)	117
<b>3.12</b>	<b>Offline auto tuning (Pr. 80 to Pr. 96)</b>	<b>120</b>
3.12.1	Offline auto tuning function (Pr. 9, Pr. 80, Pr. 81, Pr. 83, Pr. 84, Pr. 71, Pr. 96, Pr. 450, Pr. 452)	120
3.12.2	Parameters	120
3.12.3	Execution of offline auto tuning	121
3.12.4	Utilizing or changing offline auto tuning data for use	123
3.12.5	Setting the motor constants directly	124
3.12.6	Direct input + offline auto tuning	125
<b>3.13</b>	<b>Online auto tuning (Pr. 95)</b>	<b>126</b>
3.13.1	Online auto tuning selection (Pr. 95, Pr. 9, Pr. 71, Pr. 80, Pr. 81)	126
<b>3.14</b>	<b>Communication functions (Pr. 117 to Pr. 124, Pr. 342)</b>	<b>128</b>
3.14.1	Computer link operation (RS-485 communication) (Pr. 117 to Pr. 124)	128
3.14.2	E2PROM write selection (Pr. 342)	139
<b>3.15</b>	<b>PID control (Pr. 128 to Pr. 134)</b>	<b>139</b>
3.15.1	PID control (Pr. 128 to Pr. 134)	139
<b>3.16</b>	<b>Current detection (Pr. 150 to Pr. 153)</b>	<b>146</b>
3.16.1	Output current detection function (Pr. 150, Pr. 151)	146
3.16.2	Zero current detection (Pr. 152, Pr. 153)	147
<b>3.17</b>	<b>Auxiliary functions (Pr. 156, Pr. 157)</b>	<b>148</b>
3.17.1	Stall prevention operation selection (Pr. 156)	148
3.17.2	OL signal output timer (Pr. 157)	149
<b>3.18</b>	<b>Display function 3 (Pr. 160)</b>	<b>150</b>
3.18.1	Extended function display selection (Pr. 160)	150
<b>3.19</b>	<b>Initial monitor (Pr. 171)</b>	<b>150</b>
3.19.1	Actual operation hour meter clear (Pr. 171)	150
<b>3.20</b>	<b>Terminal assignment functions (Pr. 180 to Pr. 195)</b>	<b>150</b>
3.20.1	Input terminal function selection (Pr. 180 to Pr. 183, Pr. 187)	150
3.20.2	Output terminal function selection (Pr. 190 to Pr. 192, Pr. 195)	152
<b>3.21</b>	<b>Auxiliary function (Pr. 244)</b>	<b>154</b>
3.21.1	Cooling fan operation selection (Pr. 244)	154
<b>3.22</b>	<b>Stop selection function (Pr. 250)</b>	<b>154</b>
3.22.1	Stop selection (Pr. 250)	154
<b>3.23</b>	<b>Operation selection function (Pr. 251)</b>	<b>155</b>
3.23.1	Output phase failure protection selection (Pr. 251)	155
<b>3.24</b>	<b>Additional function 2 (Pr. 252, Pr. 253)</b>	<b>156</b>
3.24.1	Override bias, gain (Pr. 252, Pr. 253)	156
<b>3.25</b>	<b>Power failure stop functions (Pr. 261 to Pr. 266)</b>	<b>156</b>
3.25.1	Power-failure deceleration stop function (Pr. 261 to Pr. 266)	156
<b>3.26</b>	<b>Droop (Pr. 286 to Pr. 288)</b>	<b>158</b>
3.26.1	Droop control (Pr. 286 to Pr. 288)	158
<b>3.27</b>	<b>Orientation (Pr. 350 to Pr. 362, Pr. 393 to Pr. 399)</b>	<b>159</b>
3.27.1	Orientation control (Pr. 350, Pr. 351, Pr. 356, Pr. 357, Pr. 360 to Pr. 362, Pr. 393, Pr. 396 to Pr. 399)	159

<b>3.28 Control system function (Pr. 374)</b> .....	<b>166</b>
3.28.1 Overspeed detection (Pr. 374) .....	166
<b>3.29 Position control (Pr. 419 to Pr. 430, Pr. 464 to Pr. 494)</b> .....	<b>167</b>
3.29.1 Position control (Pr. 419 to Pr. 430, Pr. 464 to Pr. 494) .....	167
<b>3.30 Remote output (Pr. 495 to Pr.497)</b> .....	<b>168</b>
3.30.1 Remote output function (Pr. 495 to Pr.497).....	168
<b>3.31 Operation selection functions 4 (Pr. 800 to Pr. 809)</b> .....	<b>169</b>
3.31.1 Control selection (Pr. 800, Pr. 451).....	169
3.31.2 Torque characteristic selection (Pr. 801).....	169
3.31.3 Torque command source selection (Pr. 804 to Pr. 806).....	171
3.31.4 Speed limit (Pr. 807 to Pr. 809).....	173
<b>3.32 Control system functions (Pr. 818 to Pr. 837)</b> .....	<b>175</b>
3.32.1 Easy gain tuning selection (Pr. 818, Pr. 819).....	175
3.32.2 Speed loop proportional gain setting (Pr. 820, Pr. 830) .....	175
3.32.3 Speed control integral time setting (Pr. 821, Pr. 831) .....	175
3.32.4 Speed setting circuit filter function (Pr. 822, Pr. 832).....	175
3.32.5 Speed detection filter function (Pr. 823, Pr. 833) .....	176
3.32.6 Current loop proportional gain setting for vector control (Pr. 824, Pr. 834).....	176
3.32.7 Current control integral time setting for vector control (Pr. 825, Pr. 835).....	176
3.32.8 Torque setting filter function (Pr. 826, Pr. 836) .....	176
3.32.9 Torque detection filter function (Pr. 827, Pr. 837) .....	177
3.32.10 Model speed control gain (Pr. 828) .....	177
<b>3.33 Torque biases (Pr. 840 to Pr. 848)</b> .....	<b>177</b>
3.33.1 Torque bias function (Pr. 840 to Pr. 848).....	177
<b>3.34 Additional functions (Pr. 851 to Pr. 865)</b> .....	<b>180</b>
3.34.1 Selection of number of encoder pulses (Pr. 851).....	180
3.34.2 Selection of encoder rotation direction (Pr. 852).....	180
3.34.3 Excitation ratio (Pr. 854).....	181
3.34.4 Notch filter (Pr. 862, Pr. 863).....	181
3.34.5 Torque detection (Pr. 864) .....	182
3.34.6 Low speed detection (Pr. 865) .....	182
<b>3.35 Display function (Pr. 867)</b> .....	<b>183</b>
3.35.1 DA1 output response level adjustment (Pr. 867).....	183
<b>3.36 Terminal function assignment (Pr. 868)</b> .....	<b>183</b>
3.36.1 Terminal 1 function assignment (Pr. 868) .....	183
<b>3.37 Protective functions (Pr. 870 to Pr. 874)</b> .....	<b>184</b>
3.37.1 Speed deviation excessive (Pr. 870, Pr. 871) .....	184
3.37.2 Speed limit (Pr. 873).....	185
3.37.3 Stop by OLT level prevention (Pr. 874).....	185
<b>3.38 Operation selection functions 5 (Pr. 875)</b> .....	<b>186</b>
3.38.1 Fault definition (Pr. 875).....	186
<b>3.39 Control system function 2 (Pr. 877 to Pr. 881)</b> .....	<b>186</b>
3.39.1 Speed feed forward control, model adaptive speed control (Pr. 877 to Pr. 881).....	186
<b>3.40 Maintenance function (Pr. 890 to Pr. 892)</b> .....	<b>187</b>
3.40.1 Maintenance output function (Pr. 890 to Pr. 892).....	187
<b>3.41 Calibration functions (Pr. 900 to Pr. 920)</b> .....	<b>188</b>



3.41.1	DA1/DA2 terminal calibration (Pr. 900, Pr. 901).....	188
3.41.2	Biases and gains of speed setting terminals (speed setting terminal 2, torque command terminal 3, multi function terminal 1) (Pr. 902 to Pr. 905, Pr. 917 to Pr. 920).....	190
<b>3.42</b>	<b>Additional function (Pr. 990) .....</b>	<b>193</b>
3.42.1	PU buzzer control (Pr. 990).....	193

---

## **4 SPECIFICATIONS** **195**

---

<b>4.1</b>	<b>Model specifications.....</b>	<b>196</b>
<b>4.2</b>	<b>Common specifications .....</b>	<b>199</b>
<b>4.3</b>	<b>Outline dimension drawings.....</b>	<b>200</b>
4.3.1	Inverter outline dimension drawings.....	200
4.3.2	Control panel (FR-DU04-1) outline dimension drawings.....	203
4.3.3	Parameter unit (FR-PU04V) outline dimension drawings.....	203
4.3.4	Dedicated encoder cable outline dimension drawings .....	204
4.3.5	Dedicated motor outline dimension drawings.....	206

---

## **APPENDICES** **211**

---

Appendix1	Setting a thermistor of a dedicated motor (SF-V5RU****T) (when used with the FR-V5AX).....	212
Appendix2	Parameter Instruction Code List .....	213
Appendix3	SERIAL number check.....	220

# 1

# WIRING

This chapter describes the basic "wiring" for use of this product.

Always read the instructions and other information before using the equipment.

1.1	Internal block diagram .....	2
1.2	Main circuit terminal specifications .....	3
1.3	Connection of stand-alone option units.....	4
1.4	Control circuit terminal specifications.....	8
1.5	Precautions for use of the vector inverter .....	11
1.6	Others.....	12
1.7	Input terminals .....	26
1.8	How to use the input signals (assigned terminals DI1 to DI4, STR) (Pr. 180 to Pr. 183, Pr. 187).....	30
1.9	How to use the output signals (assigned terminals DO1 to DO3, ABC) (Pr. 190 to Pr. 192, Pr. 195).....	35
1.10	Design information to be checked .....	37
1.11	Using the second motor .....	38
1.12	Using the conventional motor and other motors ..	39

#### <Abbreviations>

- DU : Control panel (FR-DU04-1)
- PU : Control panel (FR-DU04-1) and parameter unit (FR-PU04V)
- Inverter : Mitsubishi vector inverter FR-V500 series
- Pr. : Parameter number
- PU operation : Operation using the PU (FR-DU04-1/FR-PU04V)
- External operation : Operation using the control circuit signals
- Combined operation : Operation using both the PU (FR-DU04-1/FR-PU04V) and external operation
- Mitsubishi dedicated motor : SF-V5R
- Mitsubishi standard motor with encoder : SF-JR
- Mitsubishi constant-torque motor : SF-HRCA

#### <Trademarks>

- CC-Link is a registered trademark of CC-Link Partner Association.
- Ethernet is a registered trademark of XEROX corporation.
- DeviceNet is a registered trademark of ODVA (Open DeviceNet Vendor Association, Inc.)
- Profibus is a registered trademark of PROFIBUS User Organization.
- Other company and product names herein are the trademarks or registered trademarks of their respective owners.

1

2

3

4

# Internal block diagram

## 1.1 Internal block diagram

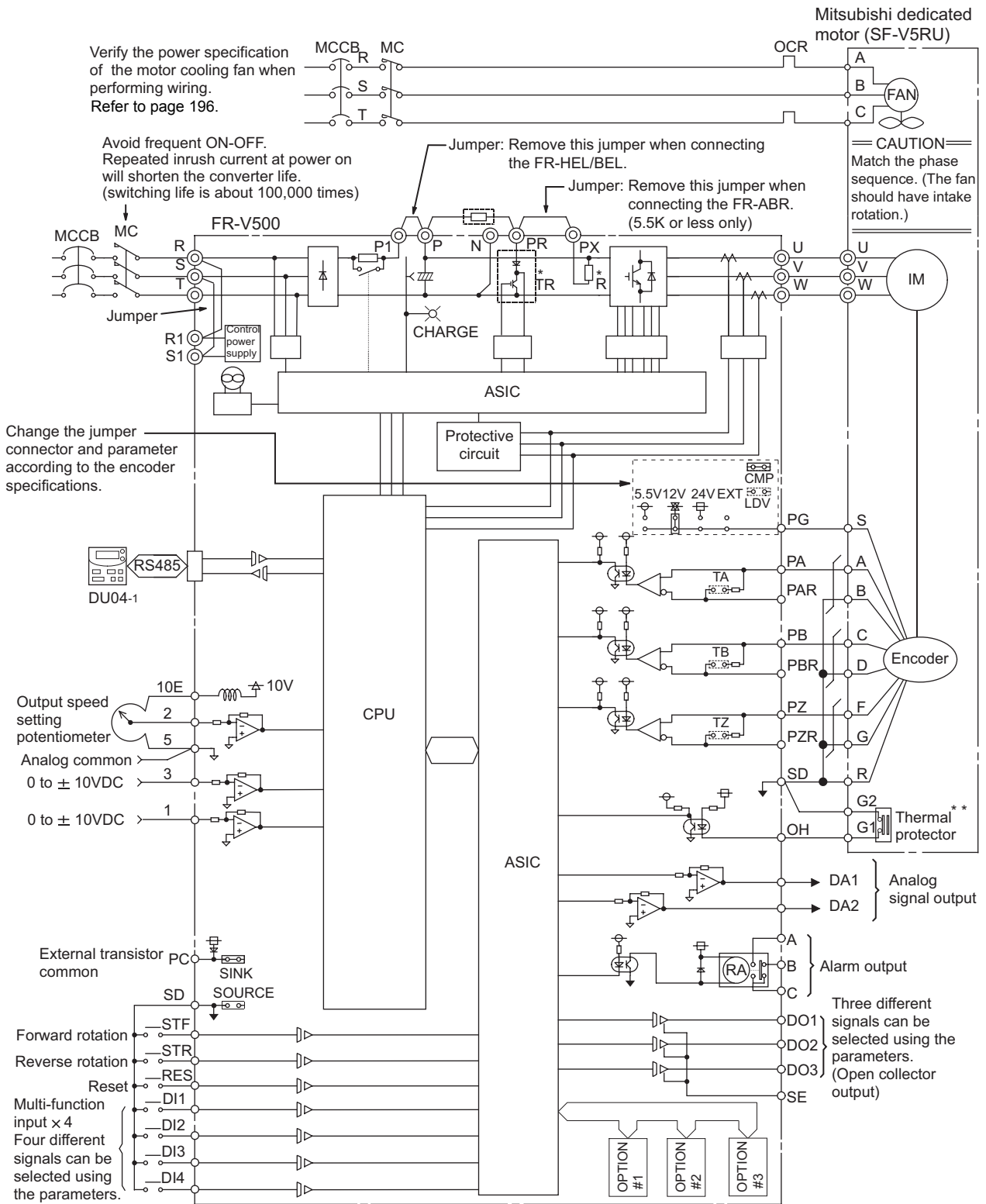

### CAUTION

1. The 18.5K or more is not equipped with the built-in brake resistor and brake transistor marked \*. The brake transistor is provided for the 15K or less and the built-in brake resistor for the 5.5K or less.
2. Always earth (ground) the inverter and motor.
3. \*\*: When using an external thermal relay protection, set "1" (external thermal relay valid) in Pr. 876. (factory setting) (Refer to page 80.)

## 1.2 Main circuit terminal specifications

Terminal Symbol	Terminal Name	Description
R, S, T	AC power input	Connect to the commercial power supply. Keep these terminals open when using the high power factor converter (FR-HC) or power regeneration common converter (FR-CV).
U, V, W	Inverter output	Connect a three-phase squirrel-cage motor or Mitsubishi dedicated motor.
R1, S1	Power supply for control circuit	Connected to the AC power supply terminals R and S. To retain the alarm display and alarm output or when using the high power factor converter (FR-HC) or power regeneration common converter (FR-CV), remove the jumpers from terminals R-R1 and S-S1 and apply external power to these terminals. Do not turn off the power supply for control circuit (R1, S1) with the main circuit power (R, S, T) on. Doing so may damage the inverter. The circuit should be configured so that the main circuit power (R, S, T) is also turned off when the power supply for control circuit (R1, S1) is off. 15K or less: 60VA, 18.5K to 55K: 80VA
P, PR	Brake resistor connection	Disconnect the jumper from terminals PR-PX (5.5K or less) and connect the optional brake resistor (FR-ABR) across terminals P-PR. For the 15K or less, connecting the resistor further provides regenerative braking power.
P, N	Brake unit connection	Connect the optional FR-BU type brake unit, BU type brake unit, power regeneration common converter (FR-CV) or high power factor converter (FR-HC).
P, P1	DC reactor connection	Disconnect the jumper from terminals P-P1 and connect the optional DC reactor (FR-HEL/BEL).
PR, PX	Built-in brake circuit connection	When the jumper is connected across terminals PX-PR (factory setting), the built-in brake circuit is valid. (Provided for the 5.5K or less.)
	Earth (Ground)	For earthing (grounding) the inverter chassis. Must be earthed (grounded).

### CAUTION

- The inverter will be damaged if power is applied to the inverter output terminals (U, V, W). Never perform such wiring.
- When connecting the dedicated external brake resistor (FR-ABR), remove jumpers across terminals PR-PX (5.5K or less).
- When connecting the brake unit (FR-BU, BU type), remove jumpers across terminals PR-PX (5.5K or less). Refer to page 5, 6.

## 1.3 Connection of stand-alone option units

The inverter accepts a variety of stand-alone option units as required.

Incorrect connection will cause inverter damage or accident. Connect and operate the option unit carefully in accordance with the corresponding option unit manual.

### 1.3.1 Connection of the dedicated external brake resistor (FR-ABR)

The built-in brake resistor is connected across terminals P and PR. Fit the external dedicated brake resistor (FR-ABR) when the built-in brake resistor does not have enough thermal capability for high-duty operation. At this time, remove the jumper from across terminals PR-PX and connect the dedicated brake resistor (FR-ABR) across terminals P-PR.

Set "1" in Pr. 30 "regenerative function selection".

Set Pr.70 "special regenerative brake duty" as follows: (Refer to page 92.)

7.5K or less . . . . .10%

11K or more . . . . .6%

**CAUTION**

1. The brake resistor connected should only be the dedicated brake resistor.
2. The jumper across terminals PR-PX (5.5K or less) must be disconnected before connecting the dedicated brake resistor. A failure to do so may damage the inverter.
3. Do not remove a jumper across terminal P and P1 except when connecting a DC reactor.

● **Model ..... FR-V520-1.5K, 2.2K, FR-V540-1.5K, 2.2K**

- 1) Remove the screws in terminals PR and PX and remove the jumper.
- 2) Connect the brake resistor across terminals P and PR. (The jumper should remain disconnected.)

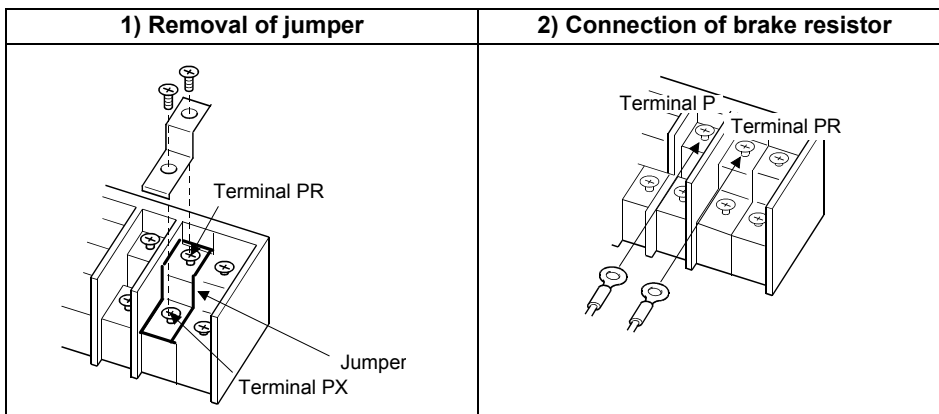

● **Model ..... FR-V520-3.7K to 7.5K, FR-V540-3.7K, 5.5K**

- 1) Remove the screws in terminals PR and PX and remove the jumper.
- 2) Connect the brake resistor across terminals P and PR. (The jumper should remain disconnected.)

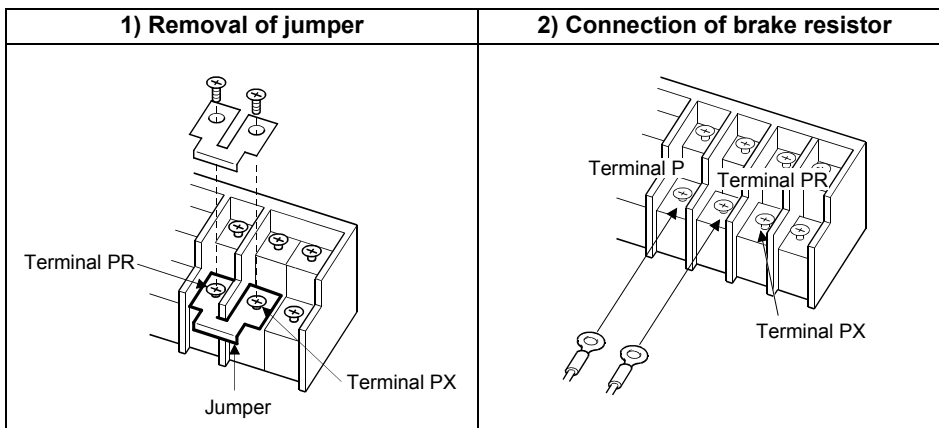

**CAUTION**

The FR-V520-7.5K does not have the PX terminal. Since it is a free terminal, keep it open.

● Model ..... FR-V520-11K to 15K, FR-V540-7.5K to 15K

1) Connect the brake resistor across terminals P and PR.

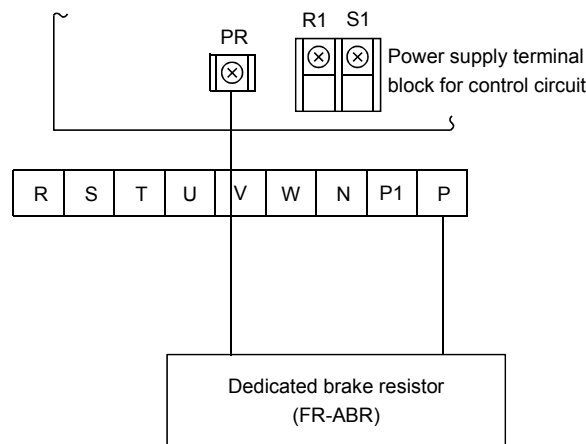

**1.3.2 Connection of the brake unit (FR-BU)**

Connect the optional FR-BU brake unit as shown below to improve the braking capability during deceleration.

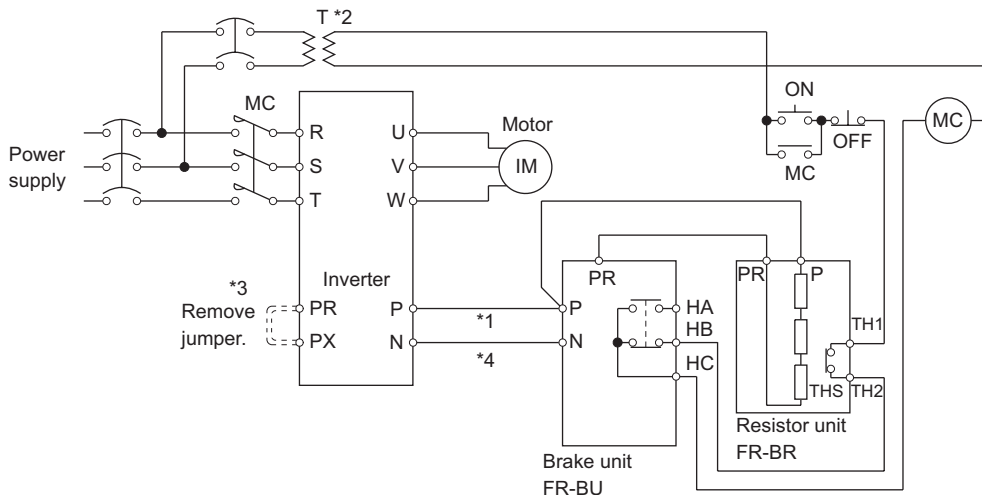

- \*1 Connect the inverter terminals (P, N) and brake unit (FR-BU (H)) terminals so that their terminal signals match with each other. (Incorrect connection will damage the inverter.)
- \*2 When the power supply is 400V class, install a step-down transformer.
- \*3 Be sure to remove a jumper across terminal PR-PX when using the FR-BU with the inverter of 5.5K or less.
- \*4 The wiring distance between the inverter, brake unit (FR-BU) and resistor unit (FR-BR) should be within 5m. If twisted wires are used, the distance should be within 10m.

**CAUTION**

- If the transistors in the brake unit should become faulty, the resistor can be unusually hot, causing a fire. Therefore, install a magnetic contactor on the inverter's input side to configure a circuit so that a current is shut off in case of fault.
- Do not remove a jumper across terminal P and P1 except when connecting a DC reactor.

## Connection of stand-alone option units

### 1.3.3 Connection of the brake unit (BU type)

Connect the BU type brake unit correctly as shown on the right. Incorrect connection will damage the inverter.

Remove the jumpers from terminals HB-PC and TB-HC and fit a jumper across terminals PC-TB of the brake unit.

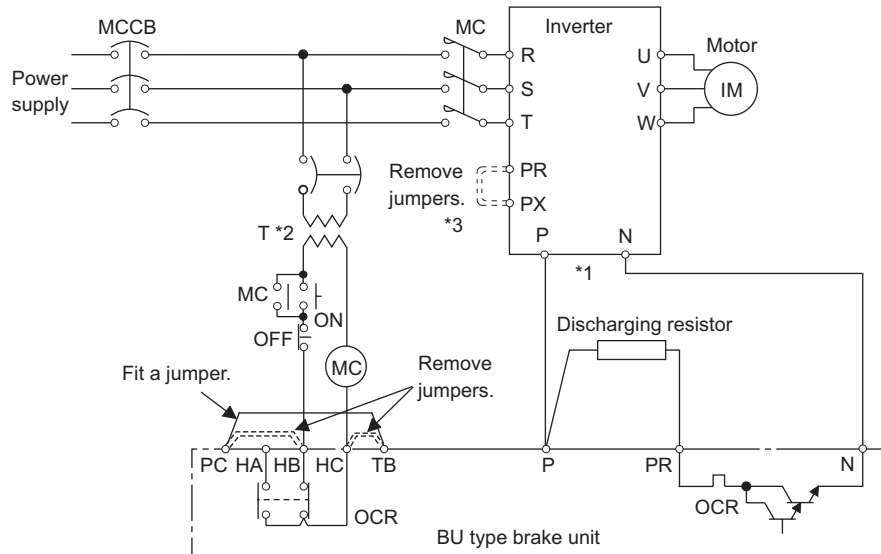

\*1 Connect the inverter terminals (P, N) and brake unit (BU type) terminals so that their terminal signals match with each other. (Incorrect connection will damage the inverter.)

\*2 When the power supply is 400V class, install a step-down transformer.

\*3 For capacity 5.5K or less, remove the jumper across terminals PR-PX.

#### CAUTION

- The wiring distance between the inverter, brake unit and resistor unit should be within 2m . If twisted wires are used, the distance should be within 5m.
- If the transistors in the brake unit should become faulty, the resistor can be unusually hot, causing a fire. Therefore, install a magnetic contactor on the inverter's power supply side to configure a circuit so that a current is shut off in case of fault.
- Do not remove a jumper across terminal P and P1 except when connecting a DC reactor.

### 1.3.4 Connection of the high power factor converter (FR-HC)

When connecting the high power factor converter (FR-HC) to suppress power supply harmonics, perform wiring securely as shown below. Incorrect connection will damage the high power factor converter and inverter. After making sure that the wiring is correct, set "2" in Pr. 30 "regenerative function selection".

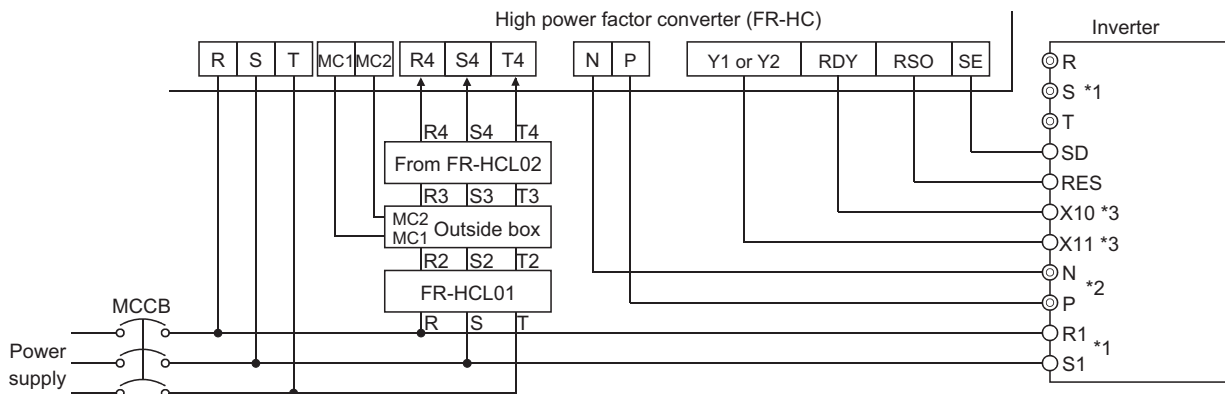

\*1 Remove the jumpers across the inverter terminals R-R1, S-S1, and connect the control circuit power supply to the R1 and S1 terminals. Always keep the power input terminals R, S, T open. Incorrect connection will damage the inverter. (E.OPT (option alarm) will occur. (Refer to the Instruction Manual (basic).))

\*2 Do not insert the MCCB between terminals P-N (P-P, N-N). Connect the inverter terminals (P, N) and high power factor converter (FR-HC) terminals so that their terminal signals match with each other. (Incorrect connection will damage the inverter.)

\*3 Use Pr. 180 to Pr. 183, Pr. 187 (input terminal function selection) to assign the terminals used for the X10 (X11) signal. (Refer to page 150.)

For communication where the start command is sent only once, e.g. when used with the computer link plug-in option (A5NR), use the X11 signal when making setting to hold the mode at occurrence of an instantaneous power failure. (Refer to page 92.)

#### CAUTION

- The voltage phases of terminals R, S, T and terminals R4, S4, T4 must be matched.
- Use sink logic (factory setting) when the FR-HC is connected. The FR-HC cannot be connected when source logic is selected.
- Do not remove a jumper across terminal P and P1 except when connecting a DC reactor.

### 1.3.5 Connection of the power regeneration common converter (FR-CV)

When connecting the FR-CV type power regeneration common converter, connect the inverter terminals (P, N) and FR-CV type power regeneration common converter terminals as shown below so that their symbols match with each other. After making sure that the wiring is correct, set "2" in Pr. 30 "regenerative function selection". Use the FR-CV with capacity one rank greater than the inverter.

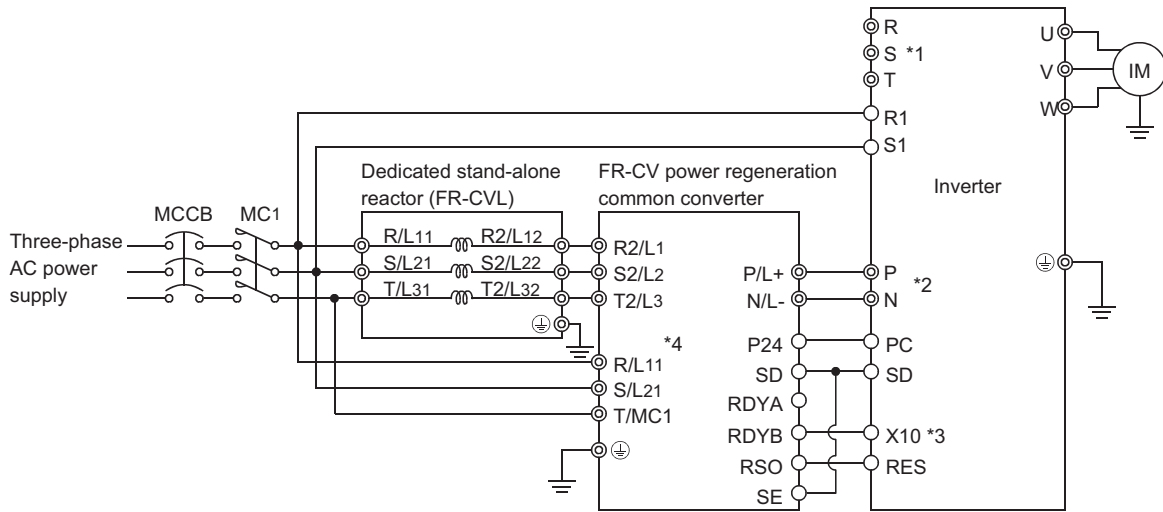

- \*1 Remove the jumpers across terminals R-R1 and S-S1 of the inverter, and connect the control circuit power supply across terminals R1-S1. Always keep the power input terminals R, S, T open. Incorrect connection will damage the inverter. (E.OPT (option alarm) will occur. (Refer to the Instruction Manual (basic).))
- \*2 Do not insert an MCCB between the terminals P – N (between P/L+ – P, between N/L- – N). Connect the inverter terminals (P, N) and power regeneration common converter (FR-CV) terminals so that their terminal signals match with each other. (Incorrect connection will damage the inverter.)
- \*3 Assign the terminal for X10 signal using any of Pr. 180 to Pr. 183. Pr.187 (input terminal function selection). (Refer to page 150)
- \*4 Be sure to connect the power supply and terminals R/L11, S/L21, T/MC1. Operating the inverter without connecting them will damage the power regeneration common converter.

#### CAUTION

1. The voltage phases of terminals R/L11, S/L21, T/MC1 and terminals R2/L1, S2/L2, T2/L3 must be matched.
2. Use sink logic (factory setting) when the FR-CV is connected. The FR-CV cannot be connected when source logic is selected.
3. Do not remove a jumper across terminal P and P1 except when connecting a DC reactor.

### 1.3.6 Connection of the DC reactor (FR-HEL/BEL)

When using the FR-HEL/BEL DC reactor, connect it between terminals P1-P. In this case, the jumper connected across terminals P1-P must be removed. Otherwise, the reactor will not exhibit its function.

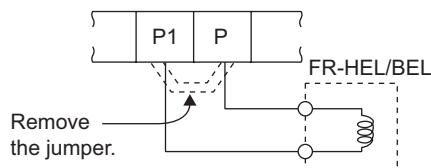

#### CAUTION

1. The wiring distance should be within 5m.
2. The size of the cables used should be equal to or larger than that of the power supply cables (R, S, T).



**1.4 Control circuit terminal specifications**

Type	Terminal Symbol	Terminal Name	Description		Rated Specifications	
Input signals	Contact input	STF	Forward rotation start	Turn on the STF signal to start forward rotation and turn it off to stop.	When the STF and STR signals are turned on simultaneously, the stop command is given.	Input resistance 4.7kΩ Voltage at opening 21 to 27VDC Current at short-circuited 4 to 6mADC Control by open collector output or 0V contact signal
		STR	Reverse rotation start	Turn on the STR signal to start reverse rotation and turn it off to stop. The function of the terminals changes according to the output terminal function selection (Pr. 187). Refer to page 150 for details.		
		DI1 to DI4	Digital input terminals 1 to 4	The function of the terminals changes according to the output terminal function selection (Pr. 180 to Pr. 183). Refer to page 150 for details.		
		OH	Thermal relay protector input	Temperature sensor terminal input for motor overheat protection. OHT error occurs when terminals OH and SD are open.	Input resistance 150kΩ Voltage at opening 21 to 27VDC Current at short-circuited 140 to 180mADC Isolate by photocoupler	
		RES	Reset	Used to reset alarm output provided when protective circuit is activated. Turn on the RES signal for more than 0.1s, then turn it off. Recover about 1s after reset is cancelled.	Input resistance 4.7kΩ Voltage at opening 21 to 27VDC Current at short-circuited 4 to 6mADC Control by open collector output or 0V contact signal.	
		SD	Contact input common (sink)	Contact input common terminal. Common output terminal for 24VDC 0.1A power supply (PC terminal). Isolated from terminals 5 and SE.	—	
	Speed setting	PC	24VDC power supply and external transistor common, contact input common (source)	When connecting a transistor output (open collector output) such as a programmable controller, connect the external power supply common for transistor output to this terminal to prevent a malfunction caused by a sneak current. PC-SD can be used as a 24VDC and 0.1A power supply. Note that a sneak current may not be prevented in this case. When source logic has been selected, this terminal serves as a contact input common.	Voltage range 18 to 26 VDC Permissible load current 0.1A	
			10E	Speed setting power supply	Used as power supply when connecting volume for speed setting (torque setting) from outside of the inverter. (terminal 5 is a common terminal)	10VDC±0.4V Permissible load current 10mA
			2	Speed setting (voltage)	By entering 0 to 10VDC, the maximum output speed is reached at 10V and I/O are proportional.	Input resistance 10kΩ±1kΩ Permissible maximum voltage 20VDC
			3	Torque setting terminal	Acts as a torque setting signal for torque control or as a torque limit signal for speed control or position control. Acts as an input terminal for the external analog-based torque bias function. 0 to ±10VDC input	
			1	Multi-function setting terminal	Since this is a multi-function selection terminal, its function varies with the Pr.868 "terminal 1 function assignment" setting. Refer to page 183 for details. 0 to ±10VDC input	
			5	Speed setting common, Analog signal output common	Common terminal for speed setting signal (terminal 2, 1 or 3) or DA1 and DA2. Isolated from terminals SD and SE. Do not earth (ground).	—

## Control circuit terminal specifications

Type	Terminal Symbol	Terminal Name	Description	Rated Specifications	
Input signals	Encoder signal	PA	A-phase signal input terminal	Differential line receiver input (AM26LS32 equivalent) or complimentary input	
		PAR	A-phase inverted signal input terminal	Differential line receiver input (AM26LS32 equivalent)	
		PB	B-phase signal input terminal	A-, B- and Z-phase signals are input from the encoder. The jumper connector is factory-set to complimentary. Thus, the encoder need not be connected to PAR, PBR and PZR.	Differential line receiver input (AM26LS32 equivalent) or complimentary input
		PBR	B-phase inverted signal input terminal		Differential line receiver input (AM26LS32 equivalent)
		PZ	Z-phase signal input terminal		Differential line receiver input (AM26LS32 equivalent) or complimentary input
		PZR	Z-phase inverted signal input terminal		Differential line receiver input (AM26LS32 equivalent)
		PG	Encoder power supply terminal (Positive side)		Power supply for encoder. You can switch the power supply between 5 (5.5), 12 and 24VDC. Can be switched to the external power supply. (Refer to the instruction manual (basic) for the switchover method.)
	SD	Contact input common (sink), Power supply earth (ground) terminal	Common terminal for contact input or encoder power supply. Isolated from terminals 5 and SE. Do not earth (ground).		Power supply common
Output signals	Contact	A, B, C	Alarm output	1 changeover contact output indicating that the output has been stopped by the inverter protective function. 230VAC 0.3A, 30VDC 0.3A. Alarm: discontinuity across B-C (continuity across A-C), normal: continuity across B-C (discontinuity across A-C). The terminal function varies with the output terminal function selection (Pr. 195) setting. Refer to page 152 for details.	Contact output Permissible contact 230VAC 0.3A 30VDC 0.3A
	Open collector	DO1 to DO3	Digital output terminals 1 to 3	The terminal functions vary with the output terminal function selection (Pr. 190 to Pr. 192) settings. Refer to page 152 for details.	Open collector output Permissible load 24VDC 0.1A
		SE	Open collector output common	Common terminal for terminals DO1, DO2 and DO3. Isolated from terminals SD and 5.	—
	Analog	DA1, DA2	Analog signal output	One selected from monitoring items, such as the speed, is output.* The output signal is proportional to the magnitude of the corresponding monitoring item.	0 to ±10VDC (DA1), 0 to 10VDC (DA2), Permissible load current 1mA Resolution 12 bit load impedance 10kΩ or more
		5	Analog signal output common	Common terminal for DA1 and DA2. Isolated from terminals SD and SE. Do not earth (ground).	
Communication	RS-485	—	PU connector	With the PU connector, communication can be made through RS-485. <ul style="list-style-type: none"> <li>• Conforming standard : EIA-485 (RS-485)</li> <li>• Transmission format : Multidrop link</li> <li>• Communication speed : Maximum. 19200bps</li> <li>• Overall length : 500m</li> </ul>	

\* Not output during inverter reset.

## Control circuit terminal specifications

### 1.4.1 Connecting the control circuit to a power supply separately from the main circuit

If the magnetic contactor (MC) in the inverter power supply is opened when the protective circuit is operated, the inverter control circuit power is lost and the alarm output signal cannot be kept on. To keep the alarm signal on terminals R1 and S1 are available. In this case, connect the power supply terminals R1 and S1 of the control circuit to the primary side of the MC.

#### • Model FR-V520-1.5K, 2.2K, FR-V540-1.5K, 2.2K

##### <Connection procedure>

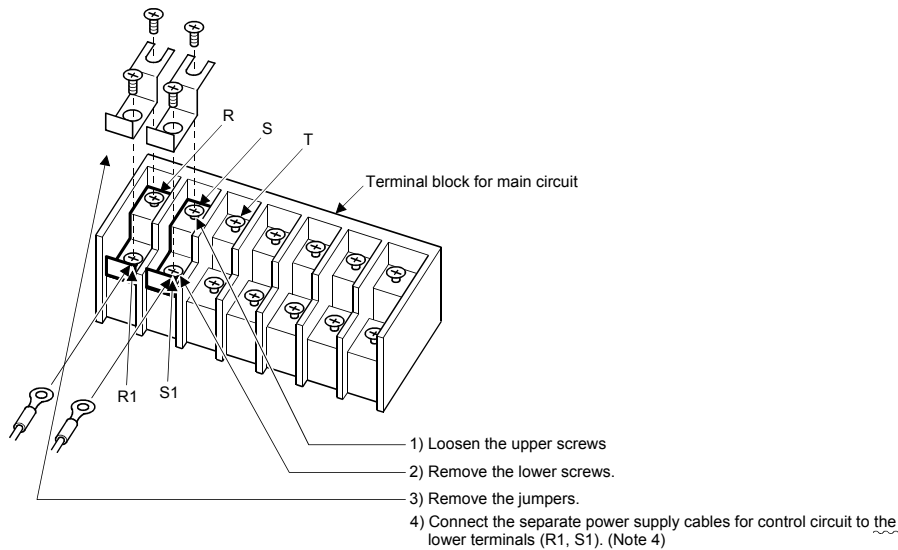

#### • Model FR-V520-3.7K to 55K, FR-V540-3.7K to 55K

##### <Connection procedure>

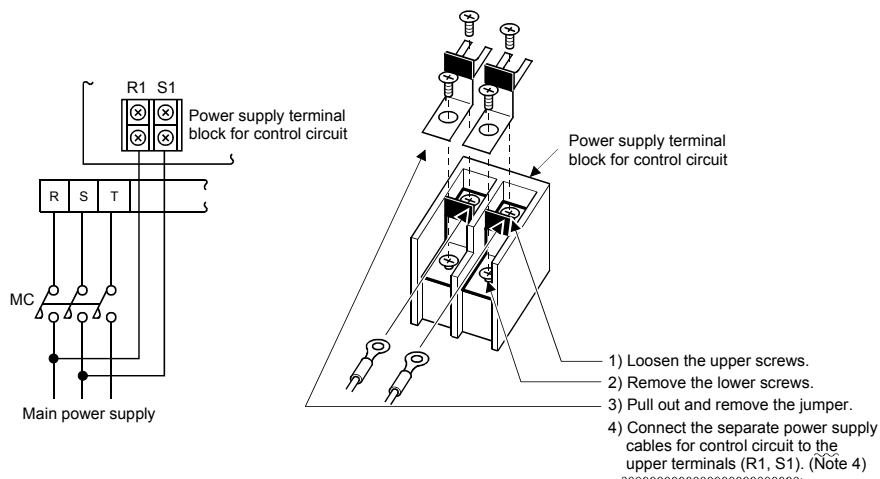

### CAUTION

1. When the main circuit power (R, S, T) is on, do not switch off the control power (terminals R1, S1). Otherwise the inverter may be damaged.
2. When using a separate power supply, the jumpers across R-R1 and S-S1 must be removed. Otherwise the inverter may be damaged.
3. For a different power supply system, which takes the power of the control circuit from other than the primary side of the MC, the voltage should be equal to the main circuit voltage.
4. For the FR-V520-3.7K to 55K, FR-V540-3.7K to 55K, the power supply cables must not be connected to the lower terminals. If connected, the inverter may be damaged.
5. Supplying power to only the R1 and S1 terminals and entering the start signal will result in an error indication (E.OC1).

## 1.5 Precautions for use of the vector inverter

The FR-V500 series is a highly reliable product, but incorrect peripheral circuit making or operation/handling method may shorten the product life or damage the product.

Before starting operation, always recheck the following items.

- (1) Use insulation-sleeved crimping terminals for the power supply and motor cables.
- (2) The inverter will be damaged if power is applied to the inverter output terminals (U, V, W).
- (3) After wiring, wire offcuts must not be left in the inverter.  
Wire offcuts can cause an alarm, fault or malfunction. Always keep the inverter clean.  
When drilling mounting holes in an enclosure etc., take care not to allow chips and other foreign matter to enter the inverter.
- (4) Wire the cables of the recommended size to make a voltage drop 2% or less.  
If the wiring distance is long between the inverter and motor, a main circuit cable voltage drop will cause the motor torque to decrease especially at the output of a high frequency.  
 Refer to Instruction Manual (basic) for the recommended wire sizes.
- (5) The overall wiring length should be 100m maximum.  
Especially for long distance wiring, the fast response current limit function may be reduced or the equipment connected to the secondary side may malfunction or become faulty under the influence of a charging current due to the stray capacity of the wiring. Therefore, note the overall wiring length.
- (6) Electromagnetic wave interference  
The input/output (main circuit) of the inverter includes high frequency components, which may interfere with the communication devices (such as AM radios) used near the inverter. In this case, install the optional FR-BIF radio noise filter (for use on the input side only) or FR-BSF01 or FR-BLF line noise filter to minimize interference.
- (7) Do not install a power factor correction capacitor, surge suppressor or radio noise filter (FR-BIF option) on the output side of the inverter.  
This will cause the inverter to trip or the capacitor and surge suppressor to be damaged. If any of the above devices is installed, immediately remove it. (When the FR-BIF radio noise filter is connected, switching power off during motor operation may result in E. UVT. In this case, connect the radio noise filter in the primary side of the magnetic contactor.)
- (8) Before starting wiring or other work after the inverter is operated, wait for at least 10 minutes after the power supply has been switched off, and check that there are no residual voltage using a tester or the like. The capacitor is charged with high voltage for some time after power off and it is dangerous.
- (9) A short circuit or earth (ground) fault in the inverter output side may damage the inverter modules.
  - Fully check the insulation resistance of the circuit prior to inverter operation since repeated short circuits caused by peripheral circuit inadequacy or an earth (ground) fault caused by wiring inadequacy or reduced motor insulation resistance may damage the inverter modules.
  - Fully check the to-earth (ground) insulation and inter-phase insulation of the inverter secondary side before power on. Especially for an old motor or use in hostile atmosphere, securely check the motor insulation resistance etc.
- (10) Do not use the inverter power supply side magnetic contactor to start/stop the inverter.  
Always use the start signal (turn on/off terminals STF, STR-SD) to start/stop the inverter. (Refer to page 14.)
- (11) Across the P and PR terminals, connect only an external regenerative brake discharge resistor.  
Do not connect a mechanical brake.
- (12) Do not apply a voltage higher than the permissible voltage to the inverter I/O signal circuits.  
Application of a voltage higher than the permissible voltage to the inverter I/O signal circuits or opposite polarity may damage the I/O devices. Especially check the wiring to prevent the speed setting potentiometer from being connected incorrectly to short terminals 10E-5.
- (13) Use of single-phase power supply  
Do not use single-phase power input.
- (14) Precautions for use of any motor other than the vector control dedicated motor (SF-V5RU, SF-VR) and standard motor with encoder (SF-JR)
  - a) Vector control cannot be exercised without encoder.
  - b) Connect the encoder to the backlash-free motor shaft.
- (15) Since the rated voltage differs from the commercial power supply voltage, the Mitsubishi dedicated motor cannot perform bypass operation.

SF-V5RU	3.7kW or less	170V
	5.5kW or more	160V
SF-V5RUH	3.7kW or less	340V
	5.5kW or more	320V

### ● Capacity (VA) of separate power supply

The capacity is 60VA or more for 15kW or less and 80VA for 18.5kW to 55kW when separate power is supplied from R1, S1.

## 1.6 Others

### 1.6.1 Leakage currents and countermeasures

Leakage currents flow through static capacitances existing in the inverter I/O wiring and motor. Since their values depend on the static capacitances, carrier frequency, etc., take the following measures.

#### (1) To-earth (ground) leakage currents

Leakage currents may flow not only into the inverter's own line but also into the other lines through the earth (ground) cable, etc.

These leakage currents may operate earth (ground) leakage breakers and earth (ground) leakage relays unnecessarily.

##### ● Countermeasures

- When the carrier frequency setting is high, decrease the carrier frequency (Pr. 72) of the inverter. Note that motor noise increases. Selection of Soft-PWM (Pr. 240) will make it unoffending.
- By using earth (ground) leakage circuit breakers designed for harmonic and surge suppression in the inverter's own line and other line, operation can be performed with the carrier frequency kept high (with low noise).

#### (2) Line-to-line leakage currents

Harmonics of leakage currents flowing in static capacitances between the inverter output cables may operate the external thermal relay unnecessarily. When the wiring length is long (50m or more) for the 400V class small-capacity model (7.5kW or less), the external thermal relay is likely to operate unnecessarily because the ratio of the leakage current to the rated motor current increases.

##### ● Line-to-line leakage current data example (200V class)

Motor Capacity (kW)	Rated Motor Current(A)	Leakage Current (mA)	
		Wiring length 50m	Wiring length 100m
1.5	9.0	370	560
2.2	13.0	400	590

- Motor SF-V5RU 4P
- Carrier frequency: 13.5KHz
- Cable :2mm<sup>2</sup>4-core
- Cab tyre cable

\*The leakage currents of the 400V class are about twice larger.

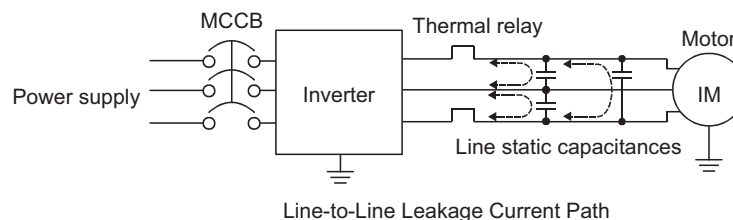

##### ● Measures

- Use the electronic thermal relay function (Pr. 9) of the inverter.
- Decrease the carrier frequency. Note that motor noise increases. Selection of Soft-PWM (Pr. 240) will make it unoffending.

For other than the dedicated motor (SF-V5RU), using a temperature sensor to directly detect the motor temperature is recommended to ensure that the motor is protected against line-to-line leakage currents.

##### ● Installation and selection of moulded case circuit breaker

Install a moulded case circuit breaker (MCCB) on the power receiving side to protect the wiring of the inverter primary side. Select the MCCB according to the power supply side power factor (which depends on the power supply voltage, output frequency and load). Especially for a completely electromagnetic MCCB, one of a slightly large capacity must be selected since its operation characteristic varies with harmonic currents. (Check it in the data of the corresponding breaker.) As an earth (ground) leakage breaker, use the Mitsubishi earth (ground) leakage breaker designed for harmonics and surges.

### (3) Selection of rated sensitivity current of earth (ground) leakage breaker

When using the earth (ground) leakage breaker with the inverter circuit, select its rated sensitivity current as follows, independently of the PWM carrier frequency.

- Breaker designed for harmonic and surge

Rated sensitivity current

$$I_{\Delta n} \geq 10 \times (I_{g1} + I_{gn} + I_{g2} + I_{gm})$$

- Standard breaker

Rated sensitivity current

$$I_{\Delta n} \geq 10 \times \{I_{g1} + I_{gn} + 3 \times (I_{g2} + I_{gm})\}$$

$I_{g1}$ ,  $I_{g2}$ : Leakage currents of cable path during commercial power supply operation

$I_{gn}$  \*: Leakage current of noise filter on inverter input side

$I_{gm}$ : Leakage current of motor during commercial power supply operation

Leakage Current Example of Cable Path per 1km during Commercial Power Supply Operation When CV Cable Is Routed in Metal Conduit (200V 60Hz)

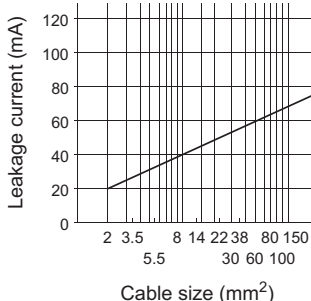

Leakage Current Example of three-Phase Induction Motor during Commercial Power Supply Operation (200V 60Hz)

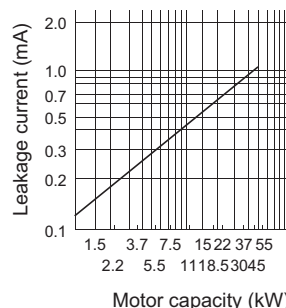

<Example>

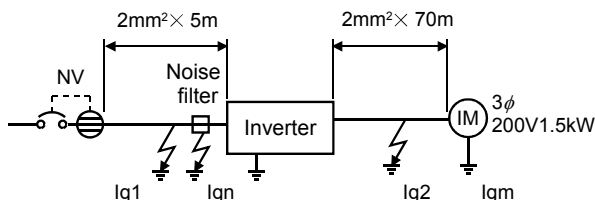

#### CAUTION

- Install the NV on the primary (power supply) side of the inverter.
- In the  $\Delta$  connection neutral point earthing (grounding) system, the sensitivity current is purified against an earth (ground) fault in the inverter secondary side. Earthing (Grounding) must conform to the requirements of national and local safety regulations and electrical codes. (NEC section 250, IEC 536 class 1 and other applicable standards)
- When the breaker is installed on the secondary side of the inverter, it may be unnecessarily operated by harmonics even if the effective value is less than the rating. In this case, do not install the breaker since the eddy current and hysteresis loss will increase, leading to temperature rise.
- The following models are standard breakers:  
 BV-C1, BC-V, NVB, NV-L, NV-G2N, NV-G3NA, and NV-2F type leakage current relays (except for NV-ZHA), NV with AA neutral wire open phase protection  
 The following models are breakers for harmonic and surge suppression:  
 NV-C/NV-S/MN series, NV30-FA, NV50-FA, BV-C2, leakage current alarm breaker (NF-Z), NV-ZHA, NV-H

\* Note the leakage current value of the noise filter installed on the inverter input side.

	Breaker Designed for Harmonic and Surge	Standard Breaker
Leakage current $I_{g1}$ (mA)	$20 \times \frac{5m}{1000m} = 0.10$	
Leakage current $I_{gn}$ (mA)	0 (without noise filter)	
Leakage current $I_{g2}$ (mA)	$20 \times \frac{70m}{1000m} = 1.40$	
Motor leakage current $I_{gm}$ (mA)	0.14	
Total leakage current (mA)	1.66	4.78
Rated sensitivity current (mA) ( $\geq I_g \times 10$ )	30	100

## 1.6.2 Power off and magnetic contactor (MC)

### (1) Inverter primary side magnetic contactor (MC)

On the inverter primary side, it is recommended to provide an MC for the following purposes.

(📖 Refer to the Instruction Manual (basic) for selection.)

- 1) To release the inverter from the power supply when the inverter protective function is activated or the drive becomes faulty (e.g. emergency stop operation)  
When cycle operation or heavy-duty operation is performed with an optional brake resistor connected, overheat and burnout of the discharging resistor can be prevented if a regenerative brake transistor is damaged due to insufficient heat capacity of the discharging resistor and excess regenerative brake duty.
- 2) To prevent any accident due to an automatic restart at restoration of power after an inverter stop made by a power failure
- 3) To rest the inverter for an extended period of time  
The control power supply for inverter is always running and consumes a little power. When stopping the inverter for an extended period of time, powering off the inverter will save power slightly.
- 4) To separate the inverter from the power supply to ensure safe maintenance and inspection work  
Since the MC on the inverter input side is used for the above purposes, they correspond to the standard duties. Therefore, when making an emergency stop during running, select a JEM1038 class AC3 MC for the inverter input side currents.

#### REMARKS

The MC may be switched on/off to start/stop the inverter. However, since repeated inrush currents at power on will shorten the life of the converter circuit (switching life is about 100,000 times), frequent starts and stops must be avoided. Turn on/off the inverter start controlling terminals (STF, STR) to run/stop the inverter.

#### ● Inverter start/stop circuit example

As shown on the right, always use the start signal (turn on/off terminals STF, STR-SD) to start/stop the inverter.

(Refer to page 26.)

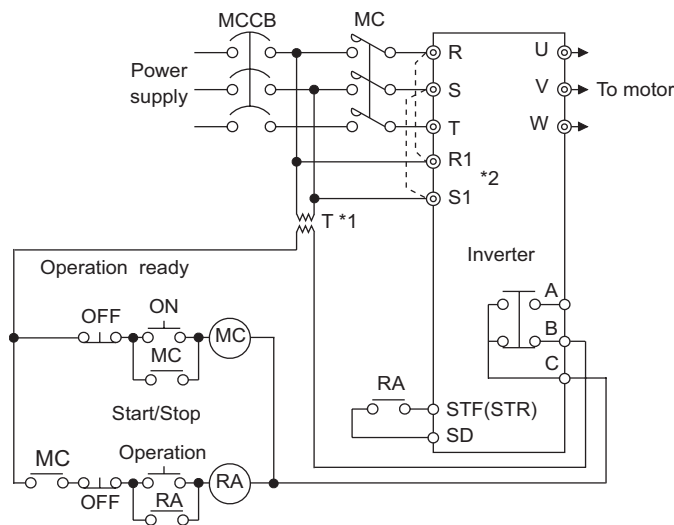

#### REMARKS

\*1. When the power supply is 400V class, install a step-down transformer.

\*2. Connect the power supply terminals R1, S1 to the primary side of the MC to hold an alarm signal when the inverter's protective circuit is activated. At this time, remove jumpers across terminals R-R1 and S-S1. (Refer to page 10 for removal of jumpers)

### (2) Handling of secondary side magnetic contactor

In principle, do not provide a magnetic contactor between the inverter and motor and switch it from off to on during operation. If it is switched on during inverter operation, a large inrush current may flow, stopping the inverter due to overcurrent shut-off. When an MC is provided for switching to the commercial power supply, for example, switch it on/off after the inverter and motor have stopped.

### 1.6.3 Installation of reactor

When the inverter is connected near a large-capacity power transformer (1000kVA or more and wiring length 10m max.) or when a power capacitor is to be switched over, an excessive peak current may flow in the power input circuit, damaging the converter circuit. To prevent this, always install the DC reactor or AC reactor (FR-HEL/BEL or FR-HAL/BAL).

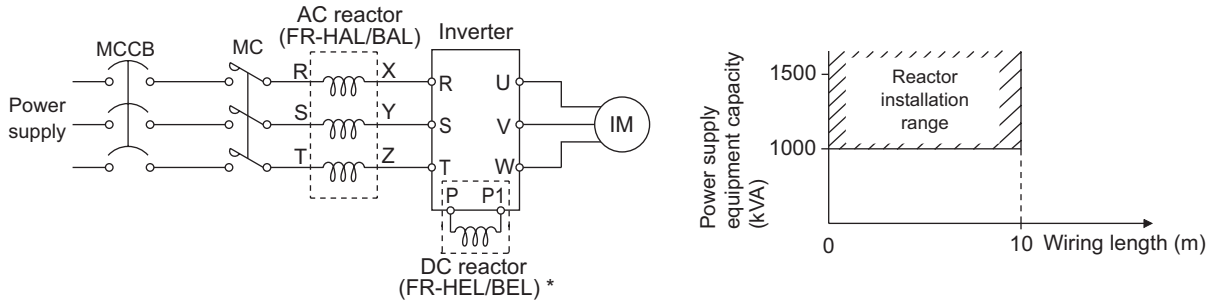

#### REMARKS

- \* When connecting the FR-HEL/BEL, remove the jumper across terminals P-P1.  
The wiring length between the FR-HEL/BEL and inverter should be 5m maximum and minimized.  
Use the same wire size as that of the power supply wire (R, S, T). (Refer to the Instruction Manual (basic).)



### 1.6.4 Notes on earthing (grounding)

- Use the dedicated earth (ground) terminal to earth (ground) the inverter. (Do not use the screw in the case, chassis, etc.)  
Use a tinned crimping terminal which does not contain zinc to connect the earth (ground) cable. Tighten the screw, taking care not to break its threads.
- Use the largest possible gauge for the earth (ground) cable. The gauge should be equal to or larger than those indicated in the following table. The earthing (grounding) point should be as near as possible to the inverter to minimize the earth (ground) cable length.

(Unit: mm<sup>2</sup>)

Motor Capacity	Earth (Ground) Cable Gauge	
	200V	400V
2.2kW or less	2 (2.5)	2 (2.5)
3.7kW	3.5 (4)	2 (2.5)
5.5kW, 7.5kW	5.5 (6)	3.5 (4)
11kW, 15kW	14 (16)	8 (10)
18.5kW to 37kW	22 (25)	14 (16)
45kW, 55kW	38 (35)	22 (25)

For use as a Low Voltage Directive-compliant product, use the PVC cables indicated in the parentheses for earthing (grounding).

- Earth (Ground) the motor on the inverter side using one wire of the 4-core cable.
- Always earth (ground) the motor and inverter.

(1) Purpose of earthing (grounding)

Generally, an electrical apparatus has an earth (ground) terminal, which must be connected to the ground before use.

An electrical circuit is usually insulated by an insulating material and encased. However, it is impossible to manufacture an insulating material that can shut off a leakage current completely, and actually, a slight current flow into the case. The purpose of earthing (grounding) the case of an electrical apparatus is to prevent operator from getting an electric shock from this leakage current when touching it.

To avoid the influence of external noises, this earthing (grounding) is important to audio equipment, sensors, computers and other apparatuses that handle low-level signals or operate very fast.

(2) Earthing (Grounding) methods and earthing (grounding) work

As described previously, earthing (grounding) is roughly classified into an electrical shock prevention type and a noise-affected malfunction prevention type. Therefore, these two types should be discriminated clearly, and the following work must be done to prevent the leakage current having the inverter's high frequency components from entering the malfunction prevention type earthing (grounding):

- Where possible, use independent earthing (grounding) for the inverter.  
If independent earthing (grounding) (I) is impossible, use joint earthing (grounding) (II) where the inverter is connected with the other equipment at an earthing (grounding) point. Joint earthing (grounding) as in (III) must be avoided as the inverter is connected with the other equipment by a common earth (ground) cable. Also a leakage current including many high frequency components flows in the earth (ground) cables of the inverter and inverter-driven motor. Therefore, they must use the independent earthing (grounding) method and be separated from the earthing (grounding) of equipment sensitive to the aforementioned noises. In a tall building, it will be a good policy to use the noise malfunction prevention type earthing (grounding) with steel frames and carry out electric shock prevention type earthing (grounding) in the independent earthing (grounding) method.
- Earthing (Grounding) must conform to the requirements of national and local safety regulations and electrical codes.  
(NEC section 250, IEC 536 class 1 and other applicable standards).
- Use the thickest possible earth (ground) cable. The earth (ground) cable should be of not less than the size indicated in the above table.
- The earthing (grounding) point should be as near as possible to the inverter to minimize the earth (ground) cable length.
- Run the earth (ground) cable as far away as possible from the I/O wiring of equipment sensitive to noises and run them in parallel in the minimum distance.
- Use one wire in a 4-core cable with the earth (ground) terminal of the motor and earth (ground) it on the inverter side.

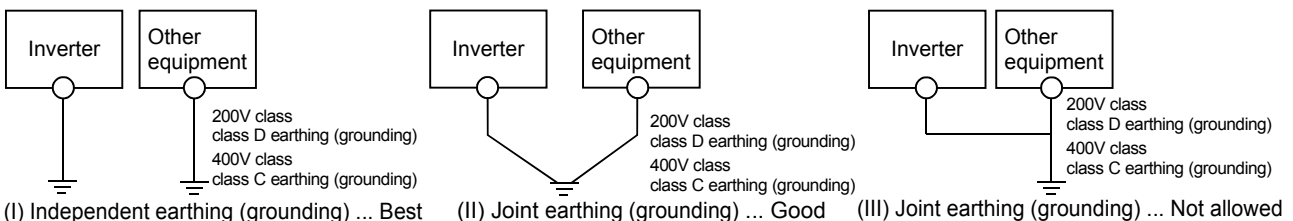

### 1.6.5 Inverter-generated noises and their reduction techniques

Some noises enter the inverter to malfunction it and others are radiated by the inverter to malfunction peripheral devices. Though the inverter is designed to be insusceptible to noises, it handles low-level signals, so it requires the following basic techniques. Also, since the inverter chops outputs at high carrier frequency, that could generate noises. If these noises cause peripheral devices to malfunction, measures should be taken to suppress noises. These techniques differ slightly depending on noise propagation paths.

- 1) Basic techniques
  - Do not run the power cables (I/O cables) and signal cables of the inverter in parallel with each other and do not bundle them.
  - Use twisted pair shielded cables for the detector connection and control signal cables, and connect the sheathes of the shield cables to terminal SD.
  - Earth (Ground) the inverter, motor, etc. at one point.
- 2) Techniques to reduce noises that enter and malfunction the inverter
 

When devices that generate many noises (which use magnetic contactors, magnetic brakes, many relays, for example) are installed near the inverter and the inverter may be malfunctioned by noises, the following measures must be taken:

  - Provide surge suppressors for devices that generate many noises to suppress noises.
  - Fit data line filters (page 18) to signal cables.
  - Earth (Ground) the shields of the detector connection and control signal cables with cable clamp metal.
- 3) Techniques to reduce noises that are radiated by the inverter to malfunction peripheral devices
 

Inverter-generated noises are largely classified into those radiated by the cables connected to the inverter and inverter main circuits (I/O), those electromagnetically and electrostatically induced to the signal cables of the peripheral devices close to the main circuit power supply, and those transmitted through the power supply cables.

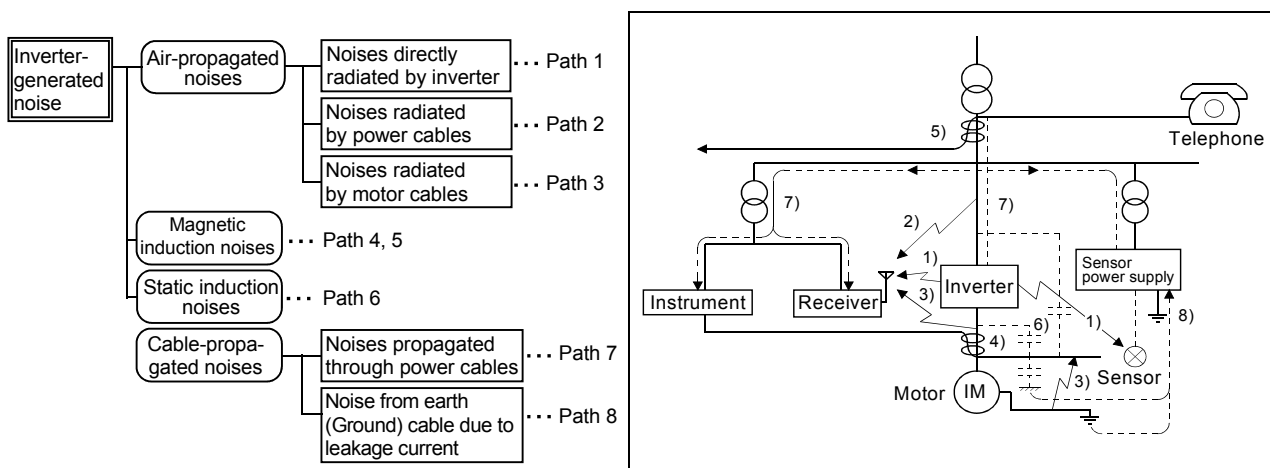

- By decreasing the carrier frequency, the mains terminal interface voltage\* can be reduced. When motor noise does not pose a problem, set the carrier frequency to a low value using Pr. 72. (\*Mains terminal interface voltage represents the magnitude of noise propagated from the inverter to the power supply side.)
- Using shield cables as signal cables, induction noise can be reduced greatly (to 1/10 - 1/100). Induction noise can also be reduced by separating the signal cables from the inverter output cables. (Separation of 30cm reduces noise to 1/2-1/3.)  
By fitting the FR-BSF01 or BLF on the inverter output side, induction noise to the signal cables can be reduced.

Noise Propagation Path	Measures
1), 2), 3)	When devices that handle low-level signals and are liable to malfunction due to noises, e.g. instruments, receivers and sensors, are contained in the enclosure that contains the inverter or when their signal cables are run near the inverter, the devices may be malfunctioned by air-propagated noises. The following measures must be taken: (1) Install easily affected devices as far away as possible from the inverter. (2) Run easily affected signal cables as far away as possible from the inverter and its I/O cables. (3) Do not run the signal cables and power cables (inverter I/O cables) in parallel with each other and do not bundle them. (4) Insert line noise filters into I/O and radio noise filters into input to suppress cable-radiated noises. (5) Use shielded cables as signal cables and power cables and run them in individual metal conduits to produce further effects.
4), 5), 6)	When the signal cables are run in parallel with or bundled with the power cables, magnetic and static induction noises may be propagated to the signal cables to malfunction the devices and the following measures must be taken: (1) Install easily affected devices as far away as possible from the inverter. (2) Run easily affected signal cables as far away as possible from the I/O cables of the inverter. (3) Do not run the signal cables and power cables (inverter I/O cables) in parallel with each other and do not bundle them. (4) Use shielded cables as signal cables and power cables and run them in individual metal conduits to produce further effects.
7)	When the power supplies of the peripheral devices are connected to the power supply of the inverter in the same line, inverter-generated noises may flow back through the power supply cables to malfunction the devices and the following measures must be taken: (1) Install the radio noise filter (FR-BIF) to the power cables (input cables) of the inverter. (2) Install the line noise filter (FR-BLF, FR-BSF01) to the power cables (I/O cables) of the inverter.
8)	When a closed loop circuit is formed by connecting the peripheral device wiring to the inverter, leakage currents may flow through the earth (ground) cable of the inverter to malfunction the device. In such a case, disconnection of the earth (ground) cable of the device may cause the device to operate properly.

● Data line filters

Noise entry can be prevented by providing a data line filter for the detector cable etc.

● Example of noise reduction techniques

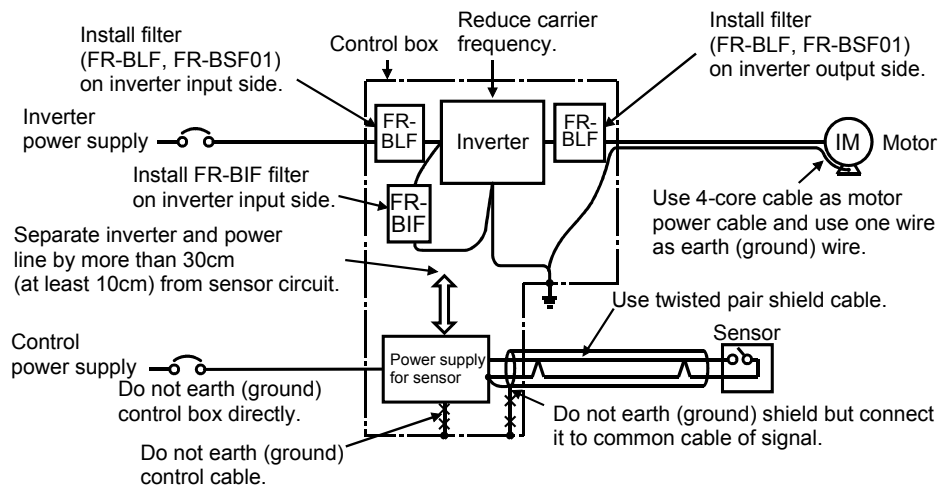

### 1.6.6 Power supply harmonics

Power supply harmonics may be generated from the converter section of the inverter, affecting the power supply equipment, power capacitors, etc. Power supply harmonics are different in generation source, frequency and transmission path from radio frequency (RF) noise and leakage currents. Take the following measures.

● **The differences between harmonics and RF noises are indicated below:**

Item	Harmonics	RF Noise
Frequency	Normally 40 to 50th degrees (3kHz or less)	High frequency (several 10kHz to 1GHz order)
Environment	To wire paths, power impedance	Across spaces, distance, laying paths
Quantitative understanding	Logical computation is possible	Occurs randomly, quantitative understanding is difficult.
Generated amount	Approximately proportional to load capacity	According to current fluctuation rate (larger with faster switching)
Immunity of affected device	Specified in standards for each device.	Differs according to maker's device specifications.
Examples of safeguard	Install a reactor.	Increase the distance.

● **Safeguard**

The harmonic current generated from the inverter to the power supply differs according to various conditions such as the wiring impedance, whether a reactor is used or not, and output frequency and output current on the load side.

For the output frequency and output current, the adequate method is to obtain them under rated load at the maximum operating frequency.

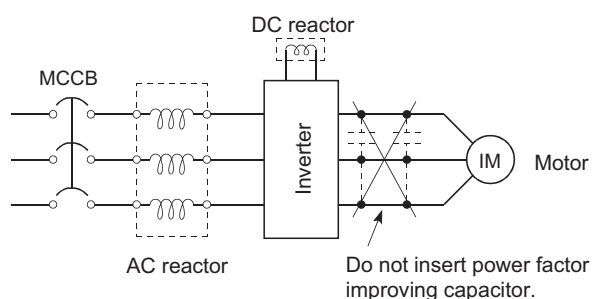

#### CAUTION

The power factor improving capacitor and surge suppressor on the inverter output side may be overheated or damaged by the high frequency components of the inverter output. Also, since an excessive current flows in the inverter to activate overcurrent protection, do not provide a capacitor and surge suppressor on the inverter output side when the motor is driven by the inverter. To improve the power factor, insert a reactor on the inverter's primary side or in the DC circuit.

### 1.6.7 Harmonic suppression guidelines

Harmonic currents flow from the inverter to a power receiving point via a power transformer. The harmonic suppression guidelines were established to protect other consumers from these outgoing harmonic currents. The three-phase 200V input specifications 3.7kW or less are previously covered by "Harmonic suppression guideline for household appliances and general-purpose products" and other models are covered by "Harmonic suppression guideline for consumers who receive high voltage or special high voltage". However, the general-purpose inverter has been excluded from the target products covered by "Harmonic suppression guideline for household appliances and general-purpose products" in January 2004. Later, this guideline was repealed on September 6, 2004. All capacities of all models are now target products of "Harmonic suppression guideline for consumers who receive high voltage or special high voltage" (hereinafter referred to as "guideline for specific consumers").

"Guideline for specific consumers"

This guideline sets forth the maximum values of harmonic currents outgoing from a high-voltage or especially high-voltage consumer who will install, add or renew harmonic generating equipment. If any of the maximum values is exceeded, this guideline requires that consumer to take certain suppression measures.

**Table 1 Maximum Values of Outgoing Harmonic Currents per 1kW Contract Power**

Received Power Voltage	5th	7th	11th	13th	17th	19th	23rd	Over 23rd
6.6kV	3.5	2.5	1.6	1.3	1.0	0.9	0.76	0.70
22kV	1.8	1.3	0.82	0.69	0.53	0.47	0.39	0.36
33kV	1.2	0.86	0.55	0.46	0.35	0.32	0.26	0.24

#### (1) Application of the guideline for specific consumers

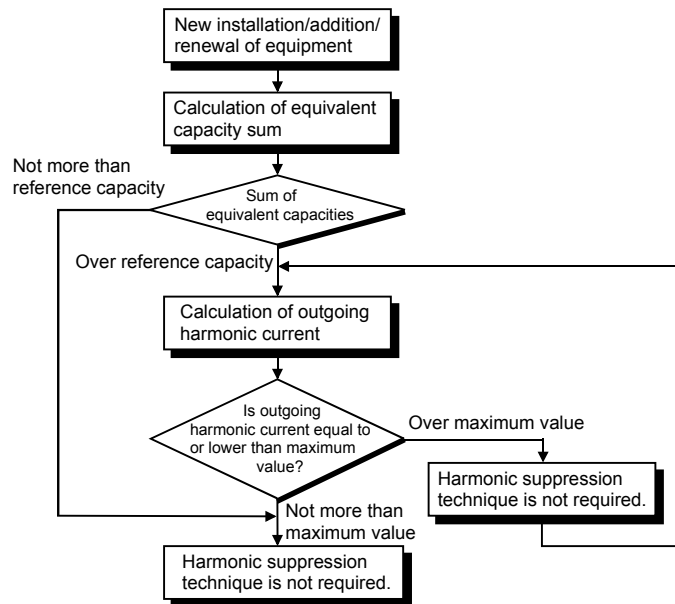

**Table 2 Conversion Factors for FR-V500 Series**

Class	Circuit Type		Conversion Factor Ki
3	Three-phase bridge (Capacitor-smoothed)	Without reactor	K31 = 3.4
		With reactor (AC side)	K32 = 1.8
		With reactor (DC side)	K33 = 1.8
		With reactors (AC, DC sides)	K34 = 1.4
5	Self-excitation three-phase bridge	When high power factor converter is used	K5 = 0

**Table 3 Equivalent Capacity Limits**

Received Power Voltage	Reference Capacity
6.6kV	50kVA
22/33kV	300kVA
66kV or more	2000kVA

Table 4 Harmonic Content (Values of the fundamental current is 100%.)

Reactor	5th	7th	11th	13th	17th	19th	23rd	25th
Not used	65	41	8.5	7.7	4.3	3.1	2.6	1.8
Used (AC side)	38	14.5	7.4	3.4	3.2	1.9	1.7	1.3
Used (DC side)	30	13	8.4	5.0	4.7	3.2	3.0	2.2
Used (AC, DC sides)	28	9.1	7.2	4.1	3.2	2.4	1.6	1.4

## 1) Calculation of equivalent capacity P0 of harmonic generating equipment

The "equivalent capacity" is the capacity of a 6-pulse converter converted from the capacity of consumer's harmonic generating equipment and is calculated with the following equation. If the sum of equivalent capacities is higher than the limit in Table 3, harmonics must be calculated with the following procedure:

$$P0 = \sum Ki \times Pi \text{ [kVA]}$$

Ki: Conversion factor (refer to Table 2)

Pi: Rated capacity of harmonic generating equipment\* [kVA]

i : Number indicating the conversion circuit type

\* Rated capacity: Determined by the capacity of the applied motor and found in Table 5. It should be noted that the rated capacity used here is used to calculate generated harmonic amount and is different from the power supply capacity required for actual inverter drive.

## 2) Calculation of outgoing harmonic current

Outgoing harmonic current = fundamental wave current (value converted from received power voltage)  
× operation ratio × harmonic content

- Operation ratio: Operation ratio = actual load factor × operation time ratio during 30 minutes
- Harmonic contents: Found in Table 4

Table 5 Rated Capacities and Outgoing Harmonic Currents for Inverter Drive

Applied Motor kW	Rated Current [A]		Fundamental Wave Current Converted from 6.6kV (mA)	Rated Capacity (kVA)	Outgoing Harmonic Current Converted from 6.6kV (mA) (No reactor, 100% operation ratio)							
	200V	400V			5th	7th	11th	13th	17th	19th	23rd	25th
1.5	5.50	2.75	167	1.95	108.6	68.47	14.20	12.86	7.181	5.177	4.342	3.006
2.2	7.93	3.96	240	2.81	156.0	98.40	20.40	18.48	10.32	7.440	6.240	4.320
3.7	13.0	6.50	394	4.61	257.1	161.5	33.49	30.34	16.94	12.21	10.24	7.092
5.5	19.1	9.55	579	6.77	376.1	237.4	49.22	44.58	24.90	17.95	15.05	10.42
7.5	25.6	12.8	776	9.07	504.4	318.2	65.96	59.75	33.37	24.06	20.18	13.97
11	36.9	18.5	1121	13.1	728.7	459.6	95.29	86.32	48.20	34.75	29.15	20.18
15	49.8	24.9	1509	17.6	980.9	618.7	128.3	116.2	64.89	46.78	39.24	27.16
18.5	61.4	30.7	1860	21.8	1209	762.6	158.1	143.2	79.98	57.66	48.36	33.48
22	73.1	36.6	2220	25.9	1443	910.2	188.7	170.9	95.46	68.82	57.72	39.96
30	98.0	49.0	2970	34.7	1931	1218	252.5	228.7	127.7	92.07	77.22	53.46
37	121	60.4	3660	42.8	2379	1501	311.1	281.8	157.4	113.5	95.16	65.88
45	147	73.5	4450	52.1	2893	1825	378.3	342.7	191.4	138.0	115.7	80.10
55	180	89.9	5450	63.7	3543	2235	463.3	419.7	234.4	169.0	141.7	98.10

## 3) Harmonic suppression technique requirement

If the outgoing harmonic current is higher than the maximum value per 1kW contract power × contract power, a harmonic suppression technique is required.

4) Harmonic suppression techniques

No.	Item	Description
1	Reactor installation (ACL, DCL)	Install a reactor (ACL) on the AC side of the inverter or a reactor (DCL) on its DC side or both to suppress outgoing harmonic currents.
2	High power factor converter (FR-HC)	The converter circuit is switched on-off to convert an input current waveform into a sine wave, suppressing harmonic currents substantially. The high power factor converter (FR-HC) is used with the standard accessory.
3	Installation of power factor improving capacitor	When used with a series reactor, the power factor improving capacitor has an effect of absorbing harmonic currents.
4	Transformer multi-phase operation	Use two transformers with a phase angle difference of 30° as in $\lambda$ -delta, delta-delta combination to provide an effect corresponding to 12 pulses, reducing low-degree harmonic currents.
5	Passive filter (AC filter)	A capacitor and a reactor are used together to reduce impedance at specific frequencies, producing a great effect of absorbing harmonic currents.
6	Active filter	This filter detects the current of a circuit generating a harmonic current and generates a harmonic current equivalent to a difference between that current and a fundamental wave current to suppress a harmonic current at a detection point, providing a great effect of absorbing harmonic currents.

**1.6.8 Inverter-driven 400V class motor**

In the PWM type inverter, a surge voltage attributable to wiring constants is generated at the motor terminals. Especially for a 400V class motor, the surge voltage may deteriorate the insulation. When the 400V class motor is driven by the inverter, consider the following measures:

● **Measures**

It is recommended to take either of the following measures.

(1) Rectifying the motor insulation

For the 400V class motor, use an insulation-enhanced motor. Specifically,

- 1) Specify the "400V class inverter-driven, insulation-enhanced motor".
- 2) For the dedicated motor such as the constant-torque motor or low-vibration motor, use the "inverter-driven, dedicated motor".

**CAUTION**

- If the wiring length between the motor and inverter is 40m or longer, set Pr. 240 to long wiring mode in addition to the above countermeasures to operate the inverter. (Refer to page 112 for Pr. 240 "Soft-PWM selection".)

### 1.6.9 Using the PU connector for computer link

#### (1) When connecting the control panel or parameter unit using a connection cable

Refer to the Instruction Manual (basic).

#### (2) For RS-485 communication

The PU connector can be used to perform communication operation from a personal computer etc. When the PU connector is connected with a personal, FA or other computer by a communication cable, a user program can run and monitor the inverter or read and write to parameters.

#### <PU connector pin-outs>

Viewed from the inverter (receptacle side) front

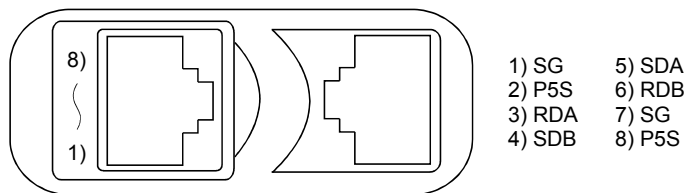

#### CAUTION

1. Do not connect the PU connector to the computer's LAN board, FAX modem socket or telephone modular connector. Otherwise, the product may be damaged due to electrical specification differences.
2. Pins No. 2 and 8 (P5S) provide power to the control panel or parameter unit. Do not use these pins for RS-485 communication.

#### <System configuration example>

#### (1) Connection of a computer to the inverter (1:1 connection)

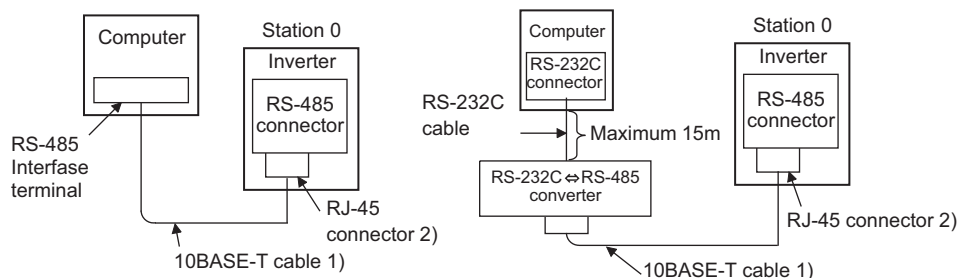

#### ●Computer - inverter connection cable

For a connection cable between the computer having RS-232C and the inverter (RS-232C↔RS-485 converter), refer to the table below.

Examples of commercially available products (as of September, '06)

Type	Maker
FA-T-RS40 type*	Mitsubishi Electric Engineering Co., Ltd

\* The converter cable cannot connect two or more inverters (the computer and inverter are connected on a 1:1 basis). Since the product is packed with the RS-232C cable and RS-485 cable (10BASE-T + RJ-45 connector), the cable and connector need not be prepared separately. Contact a maker for details of the product.

#### REMARKS

When fabricating the cable on the user side, see below.

Examples of commercially available products (as of September, '06)

	Product	Type	Maker
1)	10BASE-T cable	SGLPEV-T 0.5mm × 4P * Do not use No. 2 and No. 8 pin (P5S).	Mitsubishi Cable Industries, Ltd.
2)	RJ-45 connector	5-554720-3	Tyco Electronics Corporation



(2) Connection of a computer to multiple inverters (1:n connection)

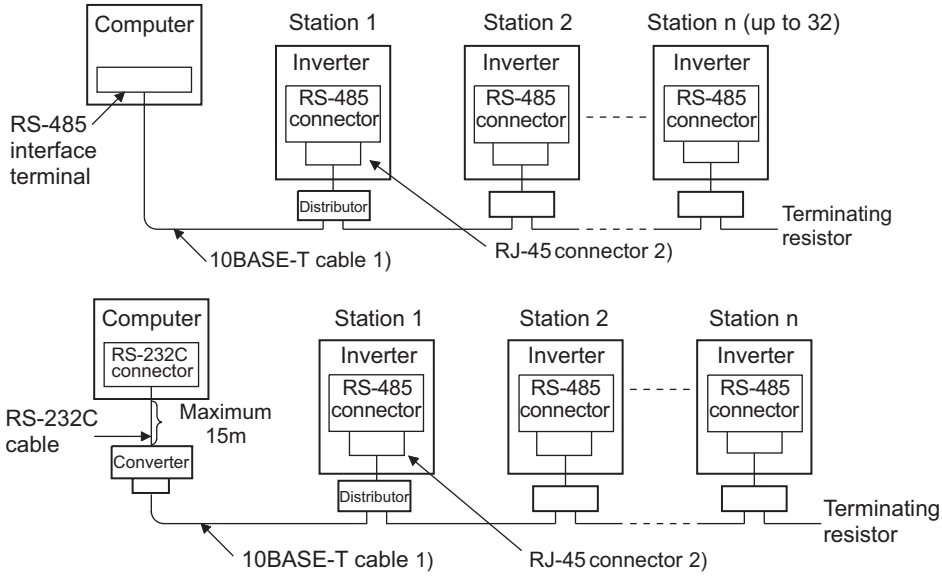

**REMARKS**

When fabricating the cable on the user side, see below.  
 Examples of commercially available products (as of September, '06)

	Product	Type	Maker
1)	10BASE-T cable	SGLPEV-T 0.5mm × 4P *	Mitsubishi Cable Industries, Ltd.
2)	RJ-45 connector	5-554720-3	Tyco Electronics Corporation

\* Do not use No. 2 and No. 8 pin (P5S) of the 10 BASE-T cable.

<Wiring method>

1) Wiring of one RS-485 computer and one inverter

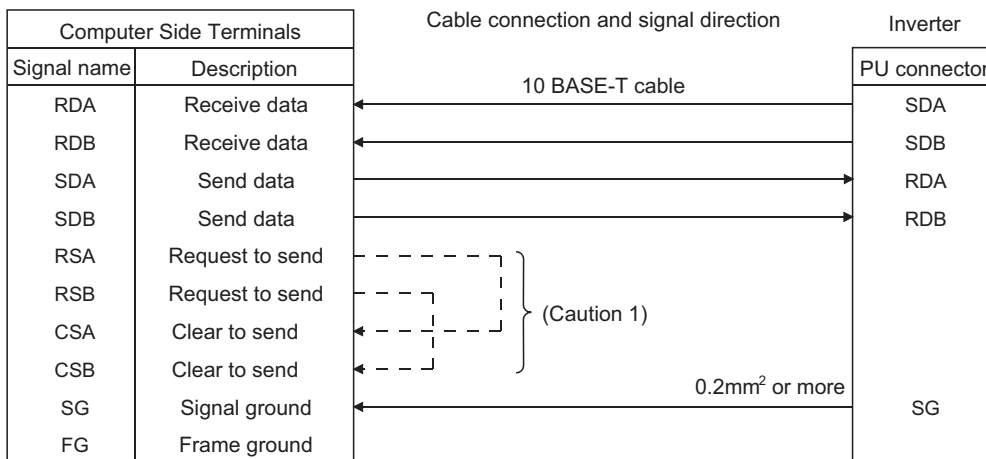

2) Wiring of one RS-485 computer and "n" (multiple) inverters

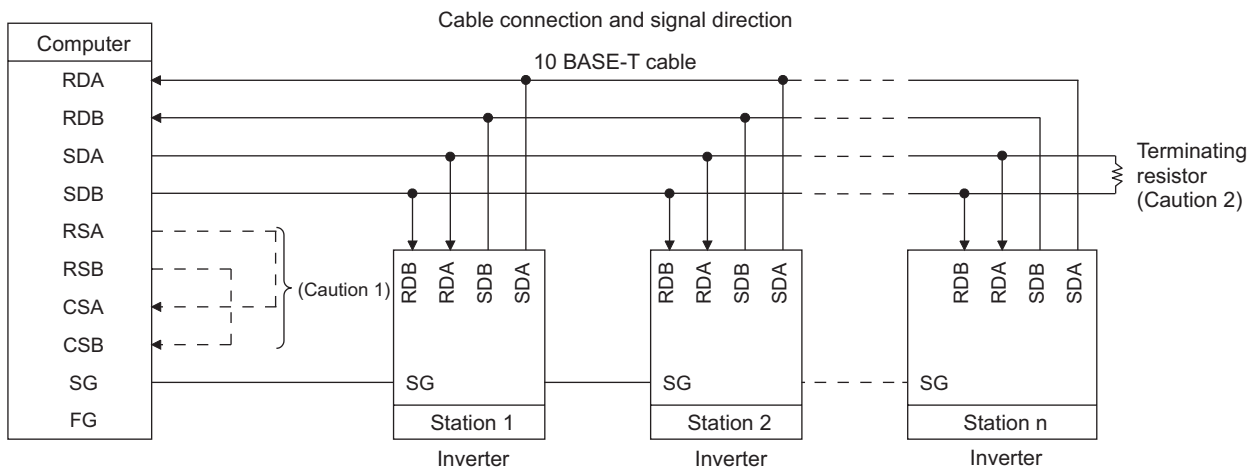

**CAUTION**

1. Make connections in accordance with the manual of the computer used. Fully check the terminal numbers of the computer since they vary with the model.
2. There may be the influence of reflection depending on the transmission speed and/or transmission distance. If this reflection hinders communication, provide a terminating resistor. If the PU connector is used to make a connection, use a distributor since a terminating resistor cannot be fitted. Connect the terminating resistor to only the inverter remotest from the computer. (terminating resistor: 100Ω)

## 1.7 Input terminals

### 1.7.1 Run (start) and stop (STF, STR, STOP)

To start and stop the motor, first switch on the input power of the inverter (when there is a magnetic contactor on the input side, use the operation-ready switch to turn on the magnetic contactor), then start the motor with the forward or reverse rotation start signal.

#### (1) Two-wire type (STF, STR)

A two-wire type connection is shown on the right.

- 1) The forward/reverse rotation signal is used as both the start and stop signals. Turn on either of the forward and reverse rotation signals to start the motor in the corresponding direction. Turn on both or turn off the start signal during operation to decelerate the inverter to a stop.
- 2) The speed setting signal may either be given by entering 0 to 10VDC across the speed setting input terminal 2-5 or by setting the required values in Pr. 4 to Pr. 6 "three-speed setting" (high, middle, low speeds). (Refer to page 77 for three-speed operation.)

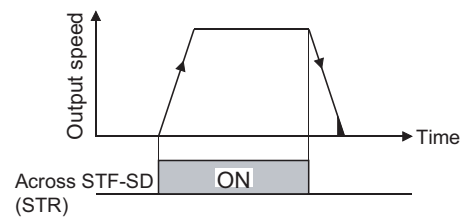
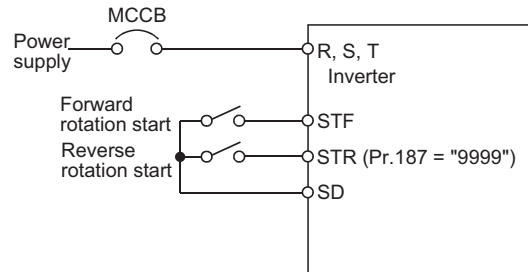

Two-Wire Type Connection Example

#### (2) Three-wire type (STF, STR, STOP)

A three-wire type connection is shown on the right. Assign the start self-holding signal (STOP) to any of the input terminals.

- 1) Short signals STOP-SD to enable the start self-holding function. In this case, the forward/reverse rotation signal functions only as a start signal.

#### REMARKS

Assign the STOP signal to any of Pr. 180 to Pr. 183 and Pr. 187 (input terminal function selection).

- 2) If the start signal terminals STF (STR)-SD are once shorted, then opened, the start signal is kept on and starts the inverter. To change the rotation direction, short the start signal STR (STF)-SD once, then open it.
- 3) The inverter is decelerated to a stop by opening terminals STOP-SD once. The three-wire connection is shown on the right.
- 4) When terminals JOG-SD are shorted, the STOP signal is invalid and jog signal has precedence.
- 5) If the output stop terminals MRS-SD are shorted, the self-holding function is not deactivated.

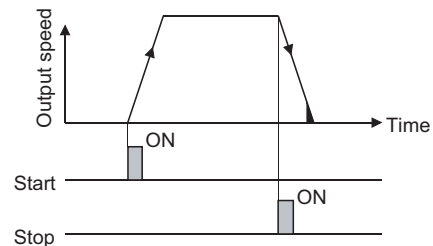
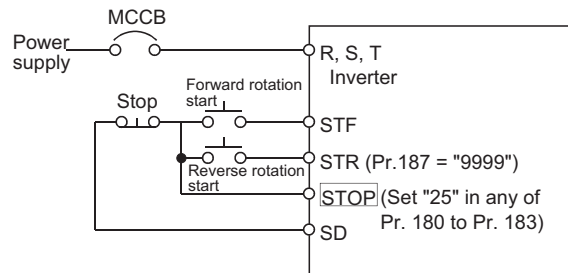

Three-Wire Type Connection Example

### 1.7.2 External thermal relay input (OH)

When the external thermal relay or the built-in thermal relay of the motor (thermal relay protector) is actuated to protect the motor from overheating, the inverter output can be shut off and the corresponding alarm signal can be provided to hold a stop status. Even if the thermal relay contact resets, the motor cannot be restarted unless the reset terminal RES-SD are shorted for more than 0.1s and then opened or a power-on reset is made.

Therefore, this function can be used as an external emergency stop signal input.

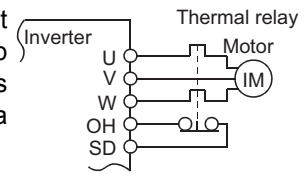

### 1.7.3 Speed setting potentiometer connection (10E, 2 (1), 5)

As an analog speed setting input signal, a voltage signal can be input.

The relationships between the speed setting input voltages and output speeds are as shown below. The speed setting input signals are proportional to the output speeds. Note that when the input signal is less than the starting speed, the output speed of the inverter is 0r/min.

If the input signal of 10VDC or higher is entered, it cannot exceed Pr. 1 "maximum speed".

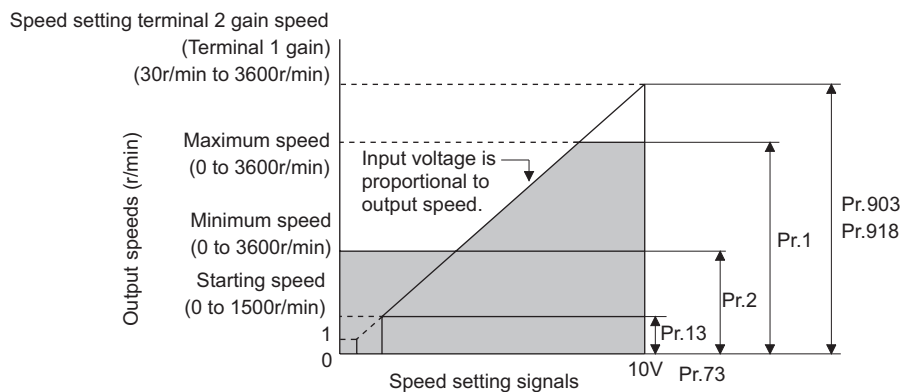

Relationships between Speed Setting Inputs and Output Speeds

#### Related parameters

Maximum speed setting Pr. 1 "maximum speed" (Refer to page 76.)

#### (1) Voltage input (10E, 2, 5)

Enter the speed setting input signal of 0 to 10VDC across the speed setting input terminals 2-5. The maximum output speed is reached when 10V is input across terminals 2-5.

The power supply used may either be the inverter's built-in power supply or an external power supply. For the built-in power supply, terminals 10E-5 provide 10VDC output.

- Use terminal 10E for the built-in power supply.

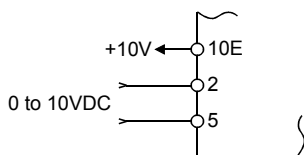

#### (2) Multi-function input (1, 5)

The analog input function can be multi-functioned, e.g. compensation signal may be entered across the main speed setting terminals 2-5 for synchronous operation.

Across auxiliary input terminals 1-5 ... 0 to ±10VDC

The function of terminal 1 depends on the setting of Pr. 868 "terminal 1 function assignment". Refer to page 183 for details of Pr. 868.

## Input terminals

### 1.7.4 Torque setting input signal and motor-generated torque (terminals 3, 5)

Refer to the diagrams shown at below right for the relationship between the torque setting input signal and output voltage. The torque setting input signal is in proportion to the output torque. However, motor-generated torque varies with the motor temperature. The guideline of the output torque accuracy relative to the torque setting input is torque accuracy  $\pm 3\%$  (under condition of  $75^{\circ}\text{C}$ ) when the SF-V5RU vector control inverter motor is used.

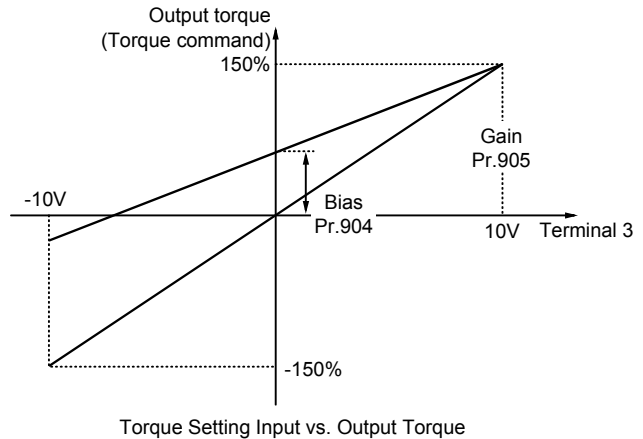
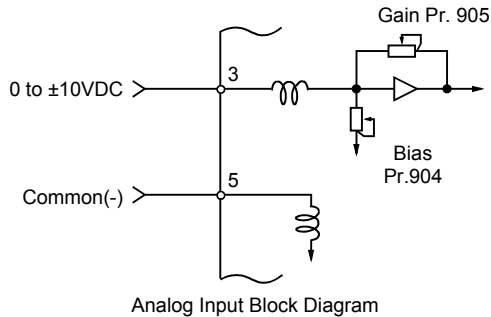

### 1.7.5 Meter connection method and adjustment (DA1, DA2)

The output speed etc. of the inverter can be displayed by connecting a meter (speed meter) across terminals DA1 (DA2)-5.

The meter can be calibrated from the control panel or parameter unit. However, if the meter is away from the inverter, the display value will vary with the wiring distance.

The terminals DA1, DA2 are non-isolated from the control circuit of the inverter. Using a shield cable of within 30m for wiring.

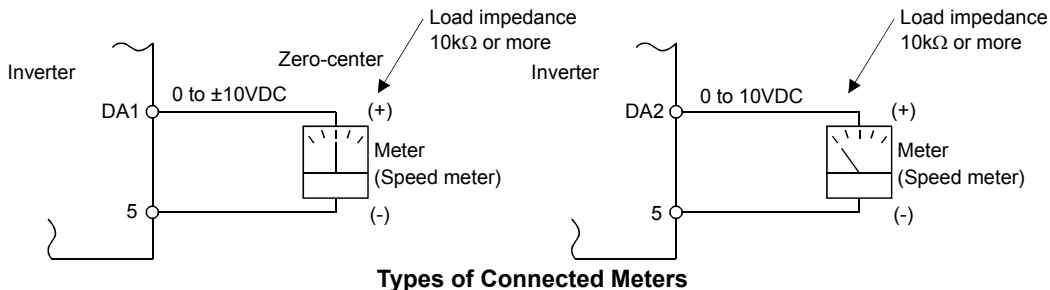

#### REMARKS

Using Pr. 867 "DA1 output filter", you can function the primary delay filter. (Refer to page 183.)

#### CAUTION



Refer to page 188 for the meter adjustment procedure.

[Example] To provide a 10V DA1-5 (DA2-5) output of 10V at the inverter output speed of 3000r/min, set "3000" (r/min) in Pr. 55. (factory setting : 1500r/min)

#### CAUTION

Note that when wiring is long, a voltage type meter is susceptible to a voltage drop, induction noise, etc. and may not read correctly.

**1.7.6 Common terminals (SD, 5, SE)**

Terminals 5, SD and SE are common to the I/O signals and isolated from each other. Do not earth (ground) these terminals. Avoid connecting the terminal SD and 5 and the terminal SE and 5.

Terminal SD is a common terminal for the contact input terminals (STF, STR, OH, RES, DI1, DI2, DI3 and DI4) and the encoder output signals. When using the terminal SD as a common terminal for the encoder output signals, use a shielded or twisted cable to protect it from external noise.

Terminal 5 is a common terminal for the speed setting analog input signals and analog output signals. Use a shielded or twisted cable to protect it from external noise.

Terminal SE is a common terminal for the open collector output terminals (DO1, DO2, DO3).

**1.7.7 Signal inputs by contact-less switches**

The contacted input terminals of the inverter (STF, STR, RH, RM, AU) can be controlled using a transistor instead of a contacted switch as shown on the right.

Input resistance : 4.7kΩ

Voltage when contacts are open : 21 to 27VDC

When contacts are short-circuited : 4 to 6mADC

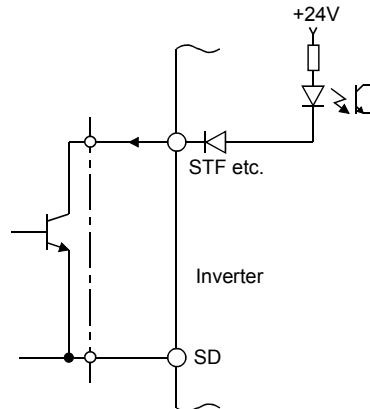

**External Signal Input by Transistor**

**REMARKS**

- When using an external transistor connected to the external power supply, use terminal PC to prevent a malfunction due to a sneak current.

(Refer to the Instruction Manual (basic) for details.)

- Note that when off, an SSR (solid-state relay) has a relatively large leakage current and it may be accidentally input to the inverter.

## 1.8 How to use the input signals (assigned terminals DI1 to DI4, STR) (Pr. 180 to Pr. 183, Pr. 187)

These terminals vary in functions with the settings of Pr. 180 to Pr. 183 and Pr. 187.

Parameter	Factory-Set Value	Factory-Set Signal	Setting Range	
Pr. 180 "DI1 terminal function selection"	0	RL	0 to 3, 5, 8 to 16, 20, 22 to 28, 42 to 44, 9999 (9999 is valid for Pr. 187 only)	Page 150
Pr. 181 "DI2 terminal function selection"	1	RM		
Pr. 182 "DI3 terminal function selection"	2	RH		
Pr. 183 "DI4 terminal function selection"	3	RT		
Pr. 187 "STR terminal function selection"	9999	STR		

The priorities of the speed commands are in order of jog, multi-speed setting (RH, RM, RL, REX) and PID (X14).

### 1.8.1 Multi-speed setting (RL, RM, RH, REX signals): Pr. 180 to Pr. 183, Pr. 187 setting "0, 1, 2, 8" Remote setting (RL, RM, RH signals): Pr. 180 to Pr. 183, Pr. 187 setting "0, 1, 2"

- When Pr. 59 = 0, turning on/off the RL, RM, RH and REX signals input as the speed commands enables multi-speed operation (15 speeds). (Refer to page 77 for details. Pr. 59 = 0)
- When Pr. 59 ≠ "0", you can use contact signals to perform continuous variable-speed operation without using analog signals even if the control panel is away from the control box. (Refer to page 103 for details.)

### 1.8.2 Second function selection/second motor switchover (RT signal) : Pr. 180 to Pr. 183, Pr. 187 setting "3"

Pr. 44 "second acceleration/deceleration time"	Pr. 830 "speed control P gain 2"
Pr. 45 "second deceleration time"	Pr. 831 "speed control integral time 2"
Pr. 450 "second applied motor"	Pr. 832 "speed setting filter 2"
Pr. 451 "second motor control method selection"	Pr. 833 "speed detection filter 2"
Pr. 452 "second electronic thermal O/L relay"	Pr. 834 "torque control P gain 2"
Pr. 453 "second motor capacity"	Pr. 835 "torque control integral time 2"
Pr. 454 "number of second motor poles"	Pr. 836 "torque setting filter 2"
	Pr. 837 "torque detection filter 2"

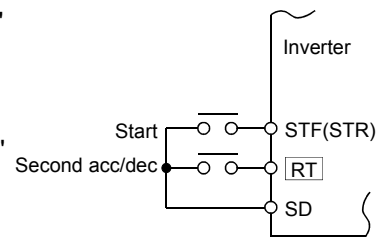

Entering the RT signal enables the second functions (above parameters). However, when Pr. 450 = 9999, it is judged that the second motor functions are not selected, and parameters Pr. 451 and Pr. 453, Pr. 454 are invalid. The second functions other than the above are enabled with the first motor.

### 1.8.3 Jog operation (jog signal): Pr. 180 to Pr. 183, Pr. 187 setting "5"

#### (1) Jog operation using external signals

Jog operation can be started/stopped by shorting the jog mode select terminal JOG-SD and shorting/opening the start signal terminal STF or STR-SD. The jog speed and jog acceleration/deceleration time are set in Pr. 15 (factory setting 150r/min, variable between 0 and 1500r/min) and Pr. 16 (factory setting 0.5s, variable between 0 and 3600s (when Pr. 21 = 0)/0 to 360s (when Pr. 21 = 1)), respectively, and their settings can be changed from the control panel or parameter unit.

The jog signal has higher priority than the multi-speed signals. (external)

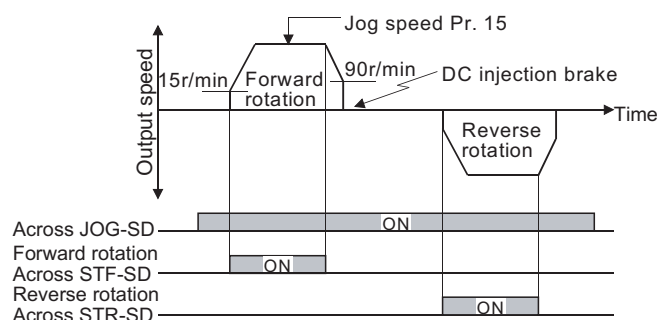

### 1.8.4 Third function selection (X9 signal): Pr. 180 to Pr. 183, Pr. 187 setting "9"

Turn on this "X9 signal" to set:  
 Pr. 110 "third acceleration/deceleration time"  
 Pr. 111 "third deceleration time"  
 Select either the first motor or the second motor according to the RT signal input.

X9 signal	RT signal	Applied Motor	Other Function
OFF	OFF	First motor	First function
OFF	ON	Second motor	Second function
ON	OFF	First motor	Third function
ON	ON	Second motor	Third function

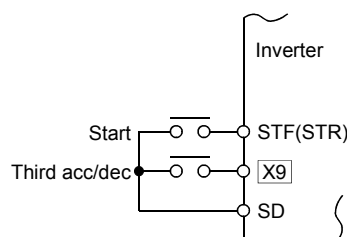

### 1.8.5 FR-HC, FR-CV connection (X10 signal): Pr. 180 to Pr. 183, Pr. 187 setting "10"

- FR-HC, FR-CV connection (inverter operation enable signal)  
 To provide protective coordination with the high power factor converter (FR-HC) or power regeneration common converter (FR-CV), use the inverter operation enable signal to shut off the inverter output. Enter the RDY signal of the high power factor converter or power regeneration common converter.

### 1.8.6 PU operation external interlock signal (X12 signal): Pr. 180 to Pr. 183, Pr. 187 setting "12"

This function prevents the inverter from being inoperative during operation using an external command if the mode is accidentally left unswitched from PU operation mode. (Refer to page 115.)

- X12 signal on ..... Shift to PU operation mode enabled (output stop during external operation)
- X12 signal off ..... Shift to PU operation mode disabled (output stop during external operation)

### 1.8.7 PID control enable terminal: Pr. 180 to Pr. 183, Pr. 187 setting "14"

Turn the X14 signal on to exercise PID control. When this signal is off, normal inverter operation is performed. Refer to page 139 for details.

#### Related parameters

Pr. 128 "PID action selection", Pr. 129 "PID proportional band", Pr. 130 "PID integral time", Pr. 131 "upper limit", Pr. 132 "lower limit", Pr. 133 "PID action set point for PU operation", Pr. 134 "PID differential time" (Refer to page 139.)

### 1.8.8 Brake sequence opening signal (BRI signal): Pr. 180 to Pr. 183, Pr. 187 setting "15"

Used when the method of inputting the mechanical brake opening completion signal to the inverter is used for the brake sequence functions. (Refer to page 106.)

#### Related parameters

Pr. 60 "intelligent mode selection", Pr. 278 "brake opening speed", Pr. 279 "brake opening current", Pr. 280 "brake opening current detection time", Pr. 281 "brake operation time at start", Pr. 282 "brake operation speed", Pr. 283 "brake operation time at stop", Pr. 284 "deceleration detection function selection", Pr. 285 "overspeed detection speed" (Refer to page 106.)

### 1.8.9 PU operation/external operation switchover: Pr. 180 to Pr. 183, Pr. 187 setting "16"

You can change the operation mode.

When Pr. 79 "operation mode selection" = "8", turning the X16 signal on shifts the current operation mode to the external operation mode and turning that signal off shifts to the PU operation mode. Refer to page 117 for details.

#### Related parameters

Pr. 79 "operation mode selection" (Refer to page 117)

### 1.8.10 S-pattern acceleration/deceleration C switchover terminal (X20 signal) : Pr. 180 to Pr. 183, Pr. 187 setting "20"

When Pr. 29 = "4", you can use the S-pattern acceleration/deceleration C switchover terminal to set the acceleration of S-pattern acceleration/deceleration in the parameter. (Refer to page 89.)

#### Related parameters

Pr. 29 "acceleration/deceleration pattern", Pr. 380 "acceleration S pattern 1", Pr. 381 "deceleration S pattern 1", Pr. 382 "acceleration S pattern 2", Pr. 383 "deceleration S pattern 2" (Refer to page 89.)



## How to use the input signals (assigned terminals DI1 to DI4, STR)

### 1.8.11 Orientation command (X22 signal): Pr. 180 to Pr. 183, Pr. 187 setting "22"

With the position detector (encoder) fitted to the motor end, you can perform position stop (orientation) control of the rotation shaft. Refer to page 159 for details.

#### Related parameters

Pr. 350 "stop position command selection", Pr. 351 "orientation switchover speed", Pr. 356 "internal stop position command", Pr. 357 "orientation in-position zone", Pr. 360 "external position command selection", Pr. 361 "position shift", Pr. 362 "orientation position loop gain", Pr. 393 "orientation selection", Pr. 396 "orientation speed gain (P term)", Pr. 397 "orientation speed integral time", Pr. 398 "orientation speed gain (D term)", Pr. 399 "orientation deceleration ratio" (Refer to page 159.)

### 1.8.12 Pre-excitation/servo on (LX signal): Pr. 180 to Pr. 183, Pr. 187 setting "23"

#### ● Pre-excitation

When the start signal (STF, STR) is not input to the inverter (during a stop), turning on the pre-excitation terminal LX enables 0 speed control or servo lock. (Refer to page 82 for details.)

#### ● Servo on

Use the LX signal to exercise position control.

Turning on the LX signal switches the servo on and cancels the base circuit shut-off, resulting in a servo lock status. (Refer to page 55 for details.)

#### Related parameters

Pre-excitation ⇒ Pr. 802 "pre-excitation selection" (Refer to page 82.)

Servo-on ⇒ Pr. 419 "position command source selection", Pr. 420 "command pulse scaling factor numerator", Pr. 421 "command pulse scaling factor denominator", Pr. 422 "position loop gain", Pr. 423 "position feed forward gain", Pr. 424 "position command acceleration/deceleration time constant", Pr. 425 "position feed forward command filter", Pr. 426 "in-position width", Pr. 427 "excessive level error", Pr. 430 "pulse monitor selection", Pr. 464 "digital position control sudden stop deceleration time", Pr. 465 to Pr. 494 (position feed amount) (Refer to page 55.)

### 1.8.13 Output stop (MRS signal): Pr. 180 to Pr. 183, Pr. 187 setting "24"

Short the output stop terminals MRS-SD during inverter output to cause the inverter to stop the output immediately.

This function is valid in any mode independently of the control mode.

Open terminals MRS-SD to resume operation in about 20ms.

Terminal MRS may be used as described below.

- (1) To stop the motor by mechanical brake (e.g. electromagnetic brake)  
Terminals MRS-SD must be shorted when the mechanical brake is operated and be opened before the motor that has stopped restarts.
- (2) To provide interlock to disable operation by the inverter  
After terminals MRS-SD have been shorted, the inverter cannot be operated if the start signal is given to the inverter.
- (3) To coast the motor to stop  
The motor is decelerated according to the preset deceleration time and is stopped by operating the DC injection brake at the DC injection brake operation speed or less. Using terminal MRS, the motor is coasted to a stop.

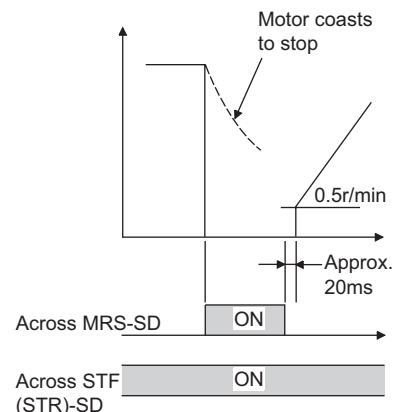

### 1.8.14 Start self-holding selection (STOP signal): Pr. 180 to Pr. 183, Pr. 187 setting "25"

The connection example given here is used to self-hold the start signal (forward rotation, reverse rotation).

\* Connected to the STOP signal to disable forward or reverse rotation if forward or reverse rotation and stop are turned on at the same time.

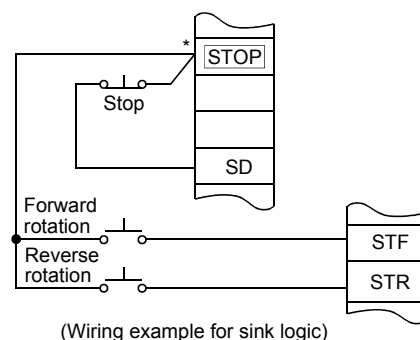

### 1.8.15 Control mode changing (MC signal): Pr. 180 to Pr. 183, Pr. 187 setting "26"

By setting Pr. 800 "control system selection", change the control mode between speed, torque and position. Refer to page 169 for details.

### 1.8.16 Torque limit selection (TL signal): Pr. 180 to Pr. 183, Pr. 187 setting "27"

By setting Pr. 815 "torque limit level 2", you can change the torque limit value. Refer to the Instruction Manual (basic) for details.

### 1.8.17 Start time tuning (X28 signal): Pr. 180 to Pr. 183, Pr. 187 setting "28"

You can perform online tuning before turning on (during stop) the start signals (STF, STR) to prevent a start time delay due to tuning.

**POINT**

- Perform offline auto tuning (page 120) and set "1" in Pr. 95 (start time tuning).
- You can perform start time tuning by X28 signal when the Y39 signal is off.
- It takes 500ms maximum for start time tuning to complete.

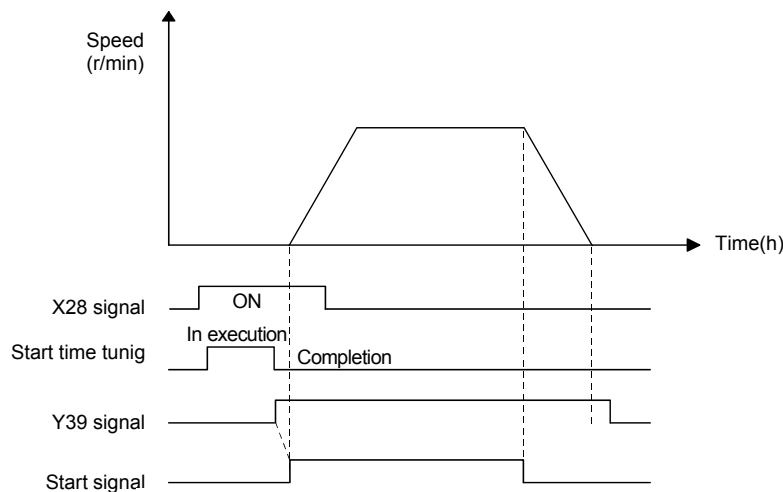

**REMARKS**

- Start time tuning is also performed with the LX signal on and a start signal by the speed command less than the starting speed (e.g. zero speed command) on.
- The Y39 signal is kept on while the second magnetic flux remains after a motor stop.
- The X28 signal is not made valid while the Y39 signal is on.
- The STF, STR and LX signals are made valid after completion of start time tuning.
- During tuning, only the output signals below are valid IPF, THP, PU, Y12, RY, ER, LF, MT, DA1, DA2, ABC.
- Invalid during V/F control.

### 1.8.18 Torque bias selection 1 (X42 signal): Pr. 180 to Pr. 183, Pr. 187 setting "42" Torque bias selection 2 (X43 signal): Pr. 180 to Pr. 183, Pr. 187 setting "43"

When using the torque bias function, you can combine the on/off of the X42 and X43 signals to select the torque bias amount. Refer to page 177 for details.

**Related parameters**

Pr. 840 "torque bias selection", Pr. 841 "torque bias 1", Pr. 842 "torque bias 2", Pr. 843 "torque bias 3", Pr. 844 "torque bias filter", Pr. 845 "torque bias operation time", Pr. 846 "torque bias balance compensation", Pr. 847 "fall-time torque bias terminal 3 bias", Pr. 848 "fall-time torque bias terminal 3 gain" (Refer to page 177.)

## How to use the input signals (assigned terminals DI1 to DI4, STR)

### 1.8.19 P control selection (P/PI control switchover) (X44 signal):

Pr. 180 to Pr. 183, Pr. 187 setting "44"

By turning the X44 signal on/off during speed control operation under vector control, you can select whether to add the integral time (I) or not when performing gain adjustment with P gain and integral time.

When the X44 signal is off: PI control

When the X44 signal is on: P control

#### Related parameters

Pr. 820 "speed control P(proportional) gain 1"

Pr. 821 "speed control integral time 1"

Pr. 830 "speed control P(proportional) gain 2"

Pr. 831 "speed control integral time 2"

Refer to page 46 for details.

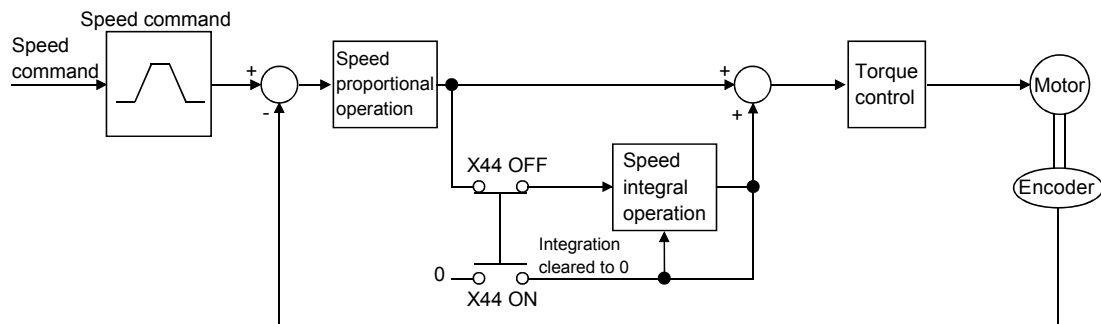

## 1.9 How to use the output signals (assigned terminals DO1 to DO3, ABC) (Pr. 190 to Pr. 192, Pr. 195)

The output terminals DO1, DO2, DO3, ABC vary in functions with the Pr. 190 to Pr. 192 and Pr. 195 settings.

Parameter	Name	Terminal Symbol	Factory Setting	Factory-Set Terminal Function	Setting Range	Remarks
190	DO1 terminal function selection	RUN	0	Inverter running	0 to 8, 10 to 16, 20, 25 to 27, 30 to 37, 39, 40 to 44, 96 to 99, 100 to 108, 110 to 116, 120, 125 to 127, 130 to 137, 139, 140 to 144, 196 to 199, 9999	Extended mode
191	DO2 terminal function selection	SU	1	Up to speed		
192	DO3 terminal function selection	IPF	2	Instantaneous power failure, undervoltage		
195	ABC terminal function selection	A, B, C	99	Alarm output		

### <Setting>

Refer to the following table for the settings of Pr. 190 to Pr. 192 and Pr. 195.

Setting		Signal Name	Function	Operation
Positive logic	Negative logic			
0	100	RUN	Inverter running	Output when the start command is input. For V/F control, this signal is output during operation when the inverter output speed rises to or above the starting speed. During DC injection brake, 0 speed control or servo lock, this signal is not output.
1	101	SU	Up to speed	Refer to Pr. 41 "up-to-speed sensitivity" (page 95).
2	102	IPF	Instantaneous power failure or undervoltage	Output at occurrence of an instantaneous power failure or undervoltage.
3	103	OL	Overload alarm	Output when torque or speed limit is activated. For V/F control, this signal is output while the stall prevention function is activated.
4	104	FU	Output speed detection	Refer to Pr. 42, Pr. 43 (speed detection) (page 95).
5	105	FU2	Second output speed detection	Refer to Pr. 50 "second speed detection" (page 95).
6	106	FU3	Third output speed detection	Refer to Pr. 116 "third speed detection" (page 95).
7	107	RBP	Regenerative brake prealarm	Output when 85% of the regenerative brake duty set in Pr. 70 is reached.
8	108	THP	Electronic thermal relay function prealarm	Output when the electronic thermal relay function cumulative value reaches 85% of the preset level.
10	110	PU	PU operation mode	Output when the PU operation mode is selected.
11	111	RY	Inverter operation ready	Output when the inverter can be started by switching the start signal on or while it is running.
12	112	Y12	Output current detection	Refer to Pr. 150 and 151 (output current detection) (page 146).
13	113	Y13	Zero current detection	Refer to Pr. 152 and 153 (zero current detection) (page 147).
14	114	FDN	PID lower limit	Refer to Pr. 128 to 134 (PID control) (page 139).
15	115	FUP	PID upper limit	
16	116	RL	PID forward-reverse rotation output	
20	120	BOF	Brake opening request	Refer to Pr. 278 to Pr. 285 (brake sequence function) (page 106).
25	125	FAN	Fan fault output	Output at the time of a fan fault.
26	126	FIN	Fin overheat prealarm	Output when the heatsink temperature reaches about 85% of the heatsink overheat protection activating temperature.
27	127	ORA	Orientation in-position	When orientation is valid
30	130	Y30	Forward rotation output	For vector control
31	131	Y31	Reverse rotation output	

**How to use the output signals (assigned terminals  
DO1 to DO3, ABC) (Pr. 190 to Pr. 192, Pr. 195)**

Setting		Signal Name	Function	Operation
Positive logic	Negative logic			
32	132	Y32	Regenerative status output	For vector control
33	133	RY2	Operation ready 2	Output on completion of pre-excitation. Turned on at an output start when pre-excitation is not made.
34	134	LS	Low speed output	Output when the speed falls to or below any preset low speed.
35	135	TU	Torque detection	Output when the motor torque rises above the predetermined value (Pr.864). (Refer to page 182.)
36	136	Y36	In-position	Acts as an in-position signal.
37	137	MT	Maintenance timer output	Refer to Pr. 890 to Pr. 892 (maintenance output function) (page 187).
39	139	Y39	Start time tuning completion	Output on completion of start time tuning
40	140	Y40	Trace status	Acts as a trace completion signal.
41	141	FB	Speed detection	Output when the motor output speed (feed back value) exceeds the preset speed. Perform in the same way as FU, FU2 and FU3 under V/F control.
42	142	FB2	Second speed detection	
43	143	FB3	Third speed detection	
44	144	RUN2	Inverter running 2	<ul style="list-style-type: none"> <li>• Output during forward rotation or the reverse rotation signal is on.</li> <li>• Output at deceleration even during forward rotation or the reverse rotation signal is off. (Does not output during pre-excitation LX is on.)</li> <li>• Output during the orientation command signal (X22) is on.</li> <li>• Switched on when the servo is on (LX-on) under position control. (Switched off when the servo is off. (LX-off))</li> </ul>
96	196	REM	Remote output	Refer to Pr. 495 to Pr.497 (page 168).
97	197	ER	Minor fault output 2	At occurrence of a major fault, the base circuit is shut off immediately. At occurrence of a minor fault, the base circuit is shut off after deceleration to a stop.
98	198	LF	Minor fault output	Output when a minor fault (fan fault or communication error alarm) occurs.
99	199	ABC	Alarm output	Output when the inverter's protective function is activated to stop the output (major fault).
9999		—	No function	—

0 to 99: Positive logic, 100 to 199: Negative logic

## 1.10 Design information to be checked

- 1) When performing bypass operation for the motor other than the vector control dedicated motor, securely provide electrical and mechanical interlocks for the MC1 and MC2 used for bypass.  
When the wiring is wrong or there is a bypass circuit as shown below, the inverter will be damaged by a sneak current from the power supply due to arcs generated at the time of switchover or chattering caused by a sequence error.
- 2) If the machine must not be restarted when power is restored after a power failure, provide a magnetic contactor in the inverter's primary side and also make up a sequence that will not turn on the start signal.  
If the start signal (start switch) remains on after a power failure, the inverter will automatically restart as soon as the power is restored.
- 3) When the power supply used with the control circuit is different from the one used with the main circuit, make up a circuit which will switch off the main circuit power supply terminals R, S, T when the control circuit power supply terminals R1, S1 are switched off.
- 4) Since the input signals to the control circuit are on a low level, use two parallel low-level signal contacts or a twin contact for contact inputs to prevent poor contact.
- 5) Do not apply a voltage to the contact input terminals (e.g. STF) of the control circuit.
- 6) Do not apply a voltage directly to the alarm output terminals (A, B, C). Always apply a voltage to these terminals via a relay coil, lamp, etc.
- 7) Fully make sure that the specifications and rating match the system requirements.

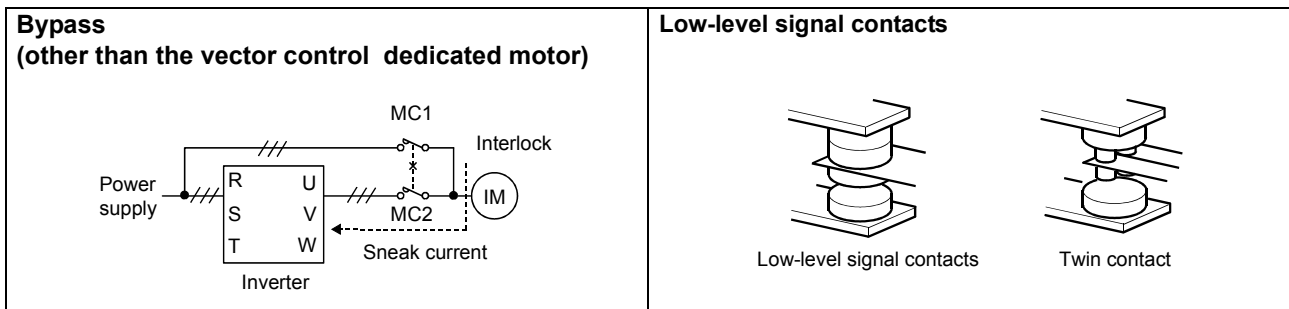

## 1.11 Using the second motor

### 1.11.1 Wiring diagram (second motor)

#### CAUTION

1. Provide interlocks to prevent the MC1 and MC2 from being turned on simultaneously.
2. For the second motor (motor without encoder), use Pr. 452 "second electronic thermal O/L relay" or provide an external thermal relay.
3. \*: Give one external thermal relay signal to across OH-SD.

#### Related parameters

Second electronic thermal relay function setting => (Pr. 452 "second electronic thermal O/L relay" (Refer to page 80.))

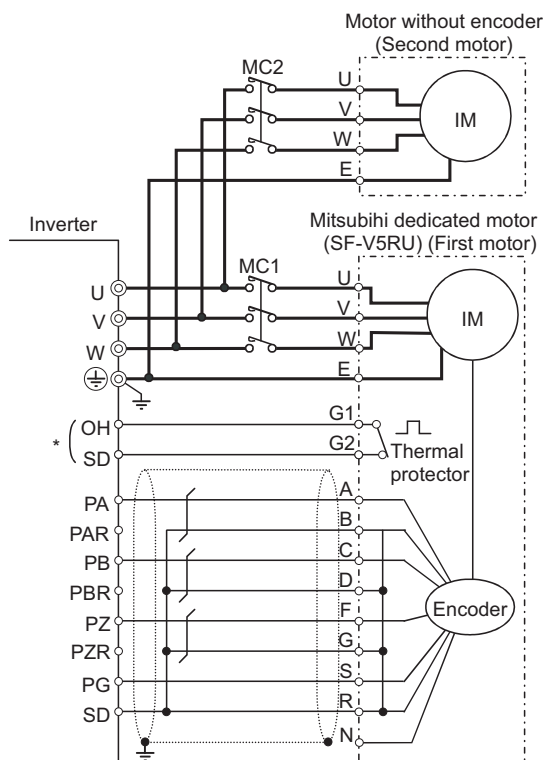

### 1.11.2 Second motor setting parameters

Parameter	Name	Factory Setting	Setting Range				
450	Second applied motor	9999	0	Mitsubishi standard motor (SF-JR)	Inverter internal constant	Refer to page 111.	
			10	Mitsubishi constant torque motor (SF-HRCA)	Inverter internal constant		
			30	SF-V5RU dedicated motor (includes SF-VR type motor)	Inverter internal constant		
			9999	Function invalid Pr. 71 "applied motor" is made valid.			
451	Second motor control method selection	9999	20	V/F control	Speed control		
			9999	Function invalid The setting is the same as that of control system of Pr. 800 "control system selection". (*)			
452	Second electronic thermal O/L relay	9999	Set the rated motor current. 0 to 500A (Refer to page 80.)				
			9999	Function invalid			
453	Second motor capacity	Inverter capacity	Set the motor capacity. 0.4 to 55kW			Setting can be made when Pr. 450 ≠ "9999"	
454	Number of second motor poles	4	Set the number of motor poles. 2, 4, 6P				

- Turn on/off the RT signal to switch between the first and second motors using contacts information of the magnetic contactor (MC).  
(Use the RT signal after setting it to any of the DI1 to DI4 signals using Pr. 180 to Pr. 183, Pr. 187 (input terminal function selection).)
- Select V/F control for the Pr. 451 setting. Vector control with encoder can not be selected.
- By setting values other than "9999" in Pr. 451 when Pr. 450 = "9999" (factory setting), the control system of the first motor can be changed by switching the RT terminal on and off.  
(In this case, turning the RT signal on makes the second function of Pr. 44, Pr. 45, Pr. 452, and Pr. 830 to Pr. 837 valid.)

#### CAUTION

\* Even when the first motor is under vector control, the second motor is V/F controlled while the RT signal is on independently of the Pr. 451 setting when Pr. 450 ≠ "9999".

## 1.12 Using the conventional motor and other motors

### 1.12.1 Conventional motor (SF-VR, SF-JR with encoder)

#### CAUTION

- When using the dedicated encoder cable (FR-VCBL/FR-JCBL) of the conventional motor for the FR-V500 series, change the size of crimping terminals of the dedicated encoder cable from M3 to M3.5.
- For the FR-V500 series inverters, the encoder jumper connector is factory set to "12V, complimentary." When using the conventional Mitsubishi motor (SF-VR-5.5 to 45kW, SF-JR with encoder), whose PLG is "5V, differential line driver" type, be sure to fit the encoder jumper connector to "5V, differential line driver" before powering on.

#### (1) Dedicated encoder cable

● SF-VR motor	● SF-JR motor with encoder																
<table border="1" style="width: 100%; border-collapse: collapse;"> <thead> <tr> <th>Type</th> <th>Length L</th> </tr> </thead> <tbody> <tr> <td>FR-VCBL5</td> <td>5m</td> </tr> <tr> <td>FR-VCBL15</td> <td>15m</td> </tr> <tr> <td>FR-VCBL30</td> <td>30m</td> </tr> </tbody> </table> <p style="text-align: center;">MS3106B20-29S (As viewed from wiring side)</p>	Type	Length L	FR-VCBL5	5m	FR-VCBL15	15m	FR-VCBL30	30m	<table border="1" style="width: 100%; border-collapse: collapse;"> <thead> <tr> <th>Type</th> <th>Length L</th> </tr> </thead> <tbody> <tr> <td>FR-JCBL5</td> <td>5m</td> </tr> <tr> <td>FR-JCBL15</td> <td>15m</td> </tr> <tr> <td>FR-JCBL30</td> <td>30m</td> </tr> </tbody> </table> <p style="text-align: center;">MS3106B20-29S (As viewed from wiring side)</p>	Type	Length L	FR-JCBL5	5m	FR-JCBL15	15m	FR-JCBL30	30m
Type	Length L																
FR-VCBL5	5m																
FR-VCBL15	15m																
FR-VCBL30	30m																
Type	Length L																
FR-JCBL5	5m																
FR-JCBL15	15m																
FR-JCBL30	30m																

#### (2) Encoder jumper connector setting

Make encoder setting according to the encoder. (Refer to the Instruction Manual (basic).)

Item	Encoder for SF-VR-5.5 to 45 kW	Encoder for SF-JR	Encoder for SF-V5RU (for reference)
Resolution	1000 pulse/rev	1024 pulse/rev	2048 Pulse/Rev
Power supply voltage	5VDC±10%	5VDC±10%	12VDC±10%
Current consumption	150mA	150mA	150mA
Output signal form	A, B phases (90° phase shift) Z phase: 1 pulse/rev	A, B phases (90° phase shift) Z phase: 1 pulse/rev	A, B phases (90° phase shift) Z phase: 1 pulse/rev
Output circuit	Differential line driver AM26LS31 equivalent	Differential line driver 74LS113 equivalent	Complimentary (Constant voltage output matched by emitter follow)
Output voltage	"H" level 2.4V or more "L" level 0.4V or less	"H" level 2.4V or more "L" level 0.5V or less	"H" level -3V or more "L" level 3V or less

#### CAUTION

Encoder with resolution of 1000 to 4096 pulse/rev is recommended.



**(3) Parameter setting**

Parameters below are extended parameters. Set "1" in Pr. 160 "extended function selection" to read and make setting.

Parameter	Name	Factory Setting	Setting Range	Refer to
9	Electronic thermal O/L relay	0A	0 to 500A	80
71	Applied motor	30	0, 3 to 8, 10, 13 to 18, 20, 23, 24, 30, 33, 34	111
80	Motor capacity	Inverter capacity	0.4 to 55kW	120
81	Number of motor poles	4	2, 4, 6	
851	Number of encoder pulses	2048	0 to 4096 (Number of pulses before multiplied by 4)	Refer to the Instruction Manual (basic)
852	Encoder rotation direction	1	0, 1	

**CAUTION**

- **Pr. 71 setting**
  - SF-VR: "30"
  - SF-JR (2, 4, 6P)- 2.2 to 55kW: "0"
  - SF-JR (4P)- 1.5kW or less: "20"
  - SF-HRCA (4P): "10"
- **When using motors other than the dedicated motor (SF-V5RU) or above motors, perform offline auto tuning. (Refer to page 120.)**

**1.12.2 Precautions for and wiring of the motor with encoder (SF-JR with encoder)**

- When the motor used is other than the dedicated motor, use the offline auto tuning function. (Refer to page 120 for details of offline auto tuning.)
- Set Pr. 800 to select the control method. (Refer to page 169.)
- To protect the motor from overheat, set electronic thermal relay function or provide an external thermal relay. (Refer to page 27.)

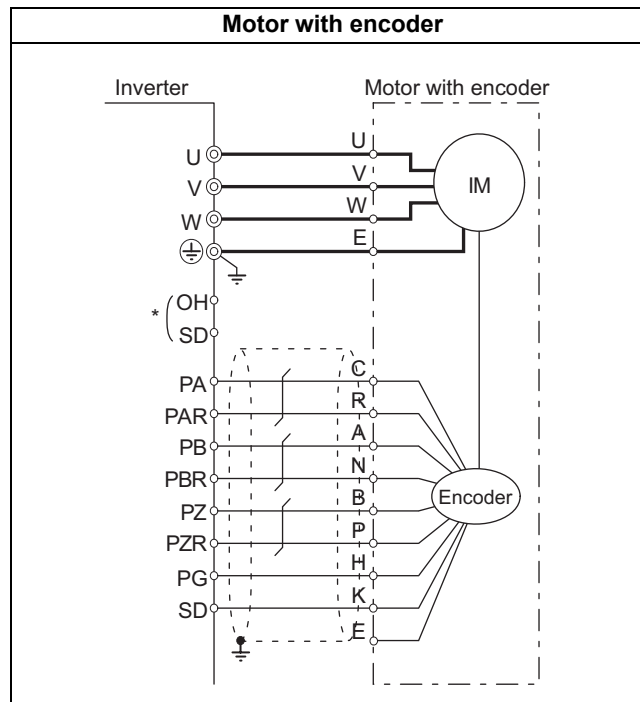

**CAUTION**

- \*Leave the unused terminals open.
- When not using an external thermal relay, set "0" in Pr. 876 "thermal relay protector input". Set Pr. 9 "electronic thermal O/L relay".
- Check the power supply specification of encoder and change a jumper connector. (Refer to the Instruction Manual (basic).)

# 2

# VECTOR CONTROL

---

This chapter explains the basic "adjustment for vector control" for use of this product.

Always read the instructions and other information before using the equipment.

---

<b>2.1</b>	<b>What is vector control? .....</b>	<b>42</b>
<b>2.2</b>	<b>Speed control .....</b>	<b>44</b>
<b>2.3</b>	<b>Fine adjustment of gains for speed control.....</b>	<b>45</b>
<b>2.4</b>	<b>Torque control .....</b>	<b>51</b>
<b>2.5</b>	<b>Fine adjustment for torque control.....</b>	<b>52</b>
<b>2.6</b>	<b>Gain adjustment for torque control .....</b>	<b>53</b>
<b>2.7</b>	<b>Position control (Pr. 419 to Pr. 430, Pr. 464 to Pr. 494).</b>	<b>55</b>

1

2

3

4

**2.1 What is vector control?**

Vector control is one of the control techniques for driving an induction motor. To help explain vector control, the fundamental equivalent circuit of an induction motor is shown below:

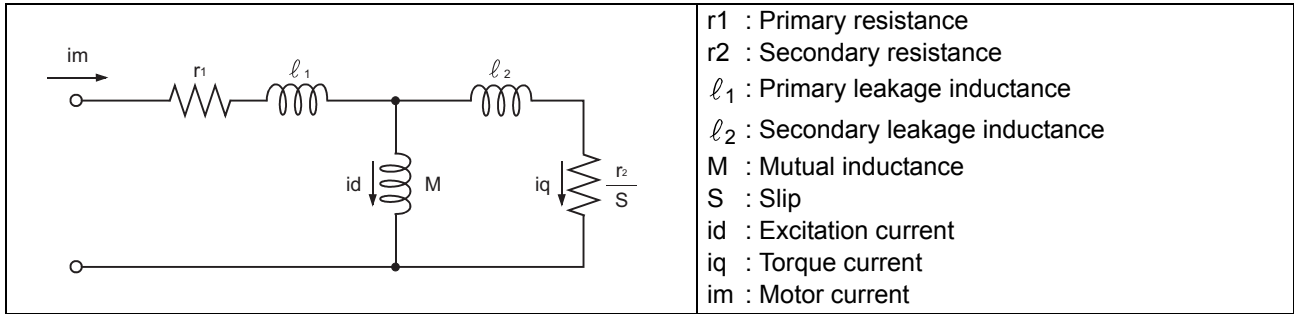

In the above diagram, currents flowing in the induction motor can be classified into a current  $i_d$  (excitation current) for making a magnetic flux in the motor and a current  $i_q$  (torque current) for causing the motor to develop a torque.

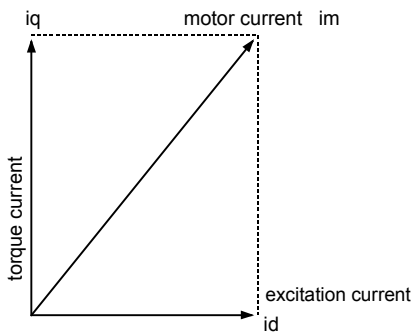

In vector control, the voltage and output frequency are calculated to control the motor so that the excitation current and torque current (as shown in the left figure) flow to the optimum as described below:

- (1) The excitation current is controlled to place the internal magnetic flux of the motor in the optimum status.
- (2) Derive the torque command value so that the difference between the motor speed command and the actual speed obtained from the encoder connected to the motor shaft is zero. Torque current is controlled so that torque as set in the torque command is developed.

Motor-generated torque ( $T_M$ ), slip angular velocity ( $\omega_s$ ) and the motor's secondary magnetic flux ( $\phi_2$ ) can be found by the following calculation:

$$T_M \propto \phi_2 \cdot i_q$$

$$\phi_2 = M \cdot i_d$$

$$\omega_s = \frac{r_2}{L_2} \cdot \frac{i_q}{i_d}$$

where,  $L_2 = \text{secondary inductance}$   
 $L_2 = l_2 + M$

Vector control provides the following advantages:

- (1) Excellent control characteristics when compared to V/F control and other control techniques, achieving the control characteristics equal to those of DC machines.
- (2) Applicable to fast response applications with which induction motors were previously regarded as difficult to use. Applications requiring a wide variable-speed range from extremely low speed to high speed, frequent acceleration/deceleration operations, continuous four-quadrant operations etc.
- (3) Allows torque control.
- (4) Allows servo-lock torque control which generates a torque at zero speed (i.e. status of motor shaft = stopped).

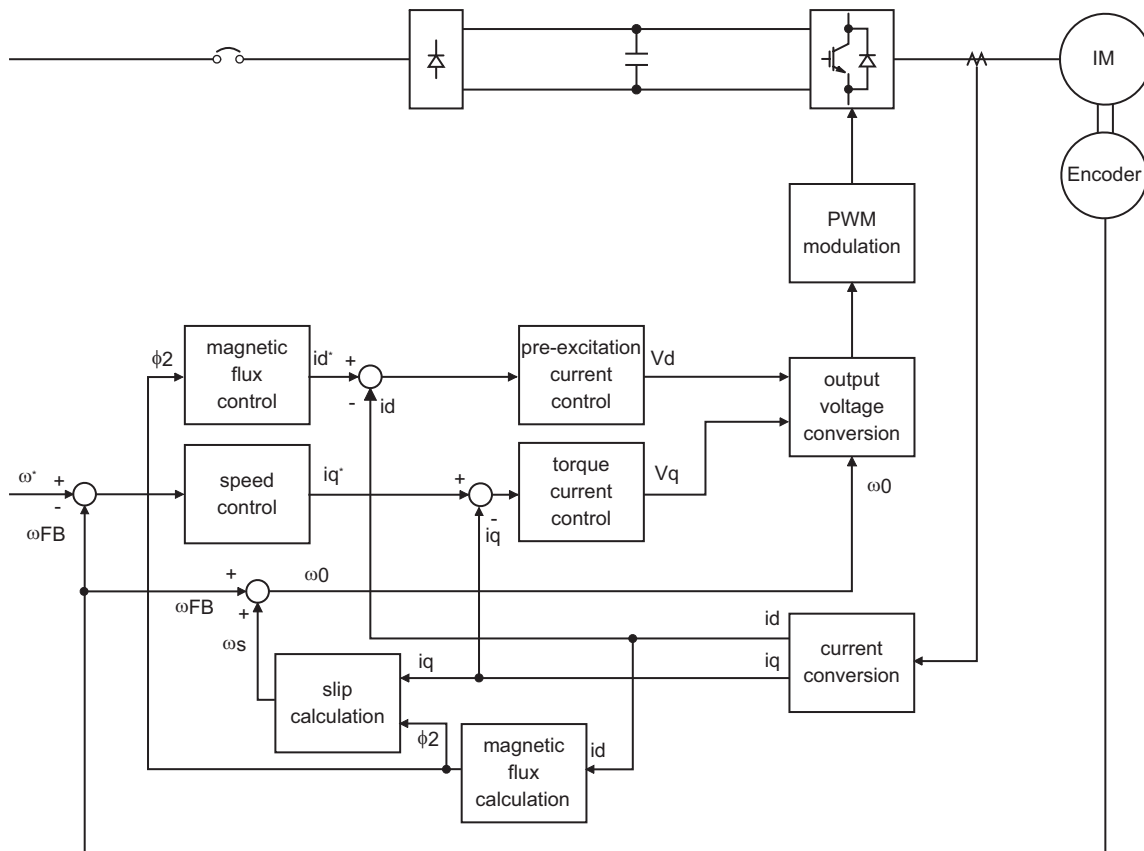

- (1) Speed control  
Speed control operation is performed to zero the difference between the speed command ( $\omega^*$ ) and actual rotation detection value ( $\omega_{FB}$ ). At this time, the motor load is found and its result is transferred to the torque current controller as a torque current command ( $i_{q^*}$ ).
- (2) Torque current control  
A voltage ( $V_q$ ) is calculated to start a current ( $i_{q^*}$ ) which is identical to the torque current command ( $i_q$ ) found by the speed controller.
- (3) Magnetic flux control  
The magnetic flux ( $\phi_2$ ) of the motor is derived from the excitation current ( $i_d$ ). The excitation current command ( $i_{d^*}$ ) is calculated to use that motor magnetic flux ( $\phi_2$ ) as a predetermined magnetic flux.
- (4) Excitation current control  
A voltage ( $V_d$ ) is calculated to start a current ( $i_d$ ) which is identical to the excitation current command ( $i_{d^*}$ ) found by magnetic flux control.
- (5) Output frequency calculation  
Motor slip ( $\omega_s$ ) is calculated on the basis of the torque current value ( $i_q$ ) and magnetic flux ( $\phi_2$ ). The output frequency ( $\omega_0$ ) is found by adding that slip ( $\omega_s$ ) to the feedback ( $\omega_{FB}$ ) found by a feedback from the encoder.

The above results are used to make PWM modulation and run the motor.

## Speed control

This inverter can control a motor under speed, torque or position control. (As required, set "1" (extended function parameters valid) in Pr. 160 "extended function selection".)

Refer to page 150 for details of Pr. 160 "extended function selection". (Since the factory setting of Pr. 77 is "0", perform parameter write in the PU mode or during a stop.)

## 2.2 Speed control

### 2.2.1 Outline of speed control

The basics of speed control are explained in the Instruction Manual (basic).

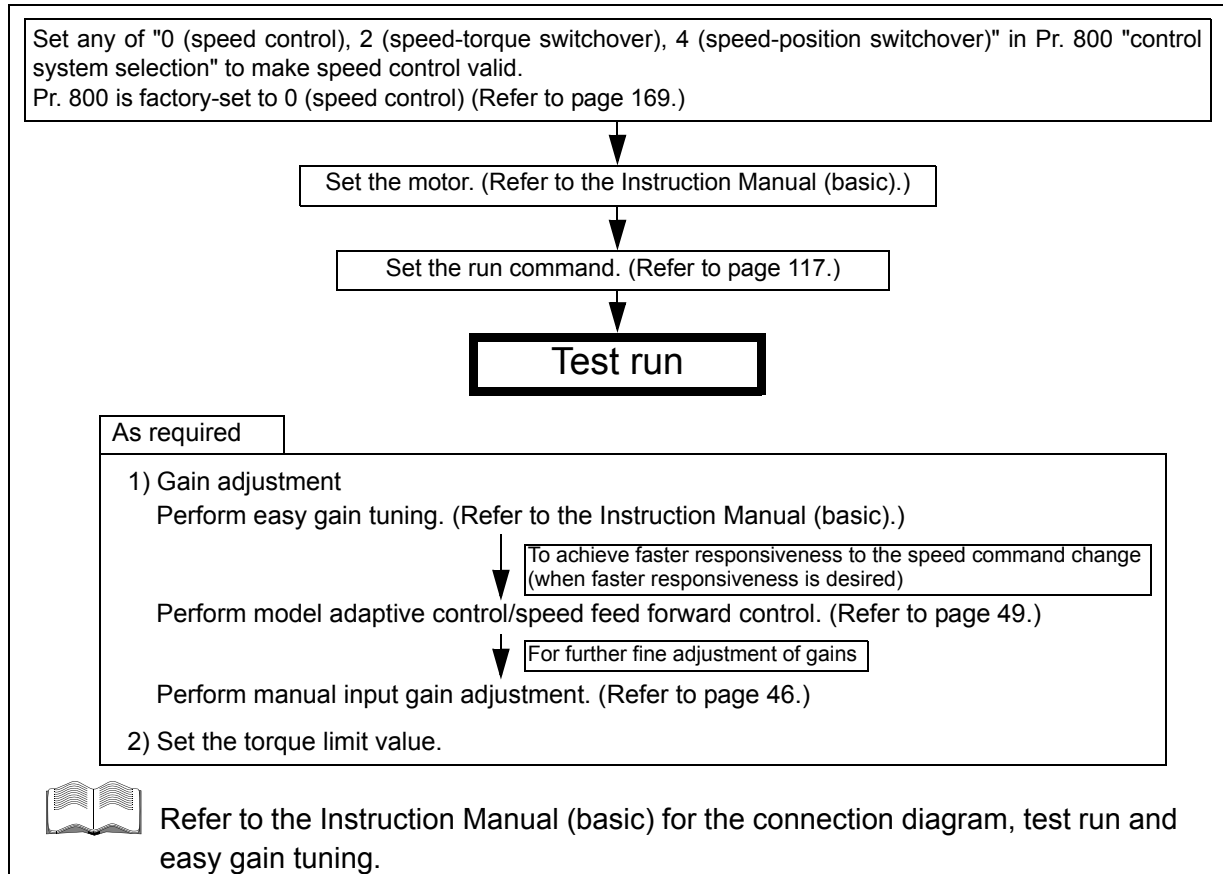

### 2.2.2 Easy gain tuning function block diagram

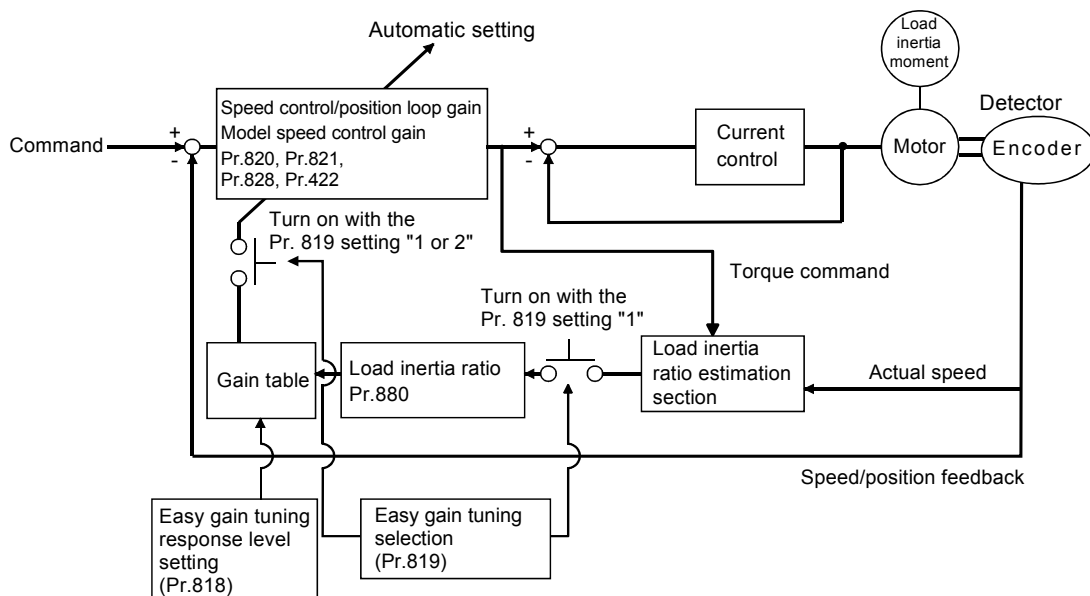

## 2.3 Fine adjustment of gains for speed control

If easy gain tuning does not provide high accuracy, refer to the next page and make adjustment.

Make adjustment when vibration, noise or any other unfavorable phenomenon occurs due to large load inertia or gear backlash, for example, or when you want to exhibit the best performance that matches the machine.

### 2.3.1 Control block diagram

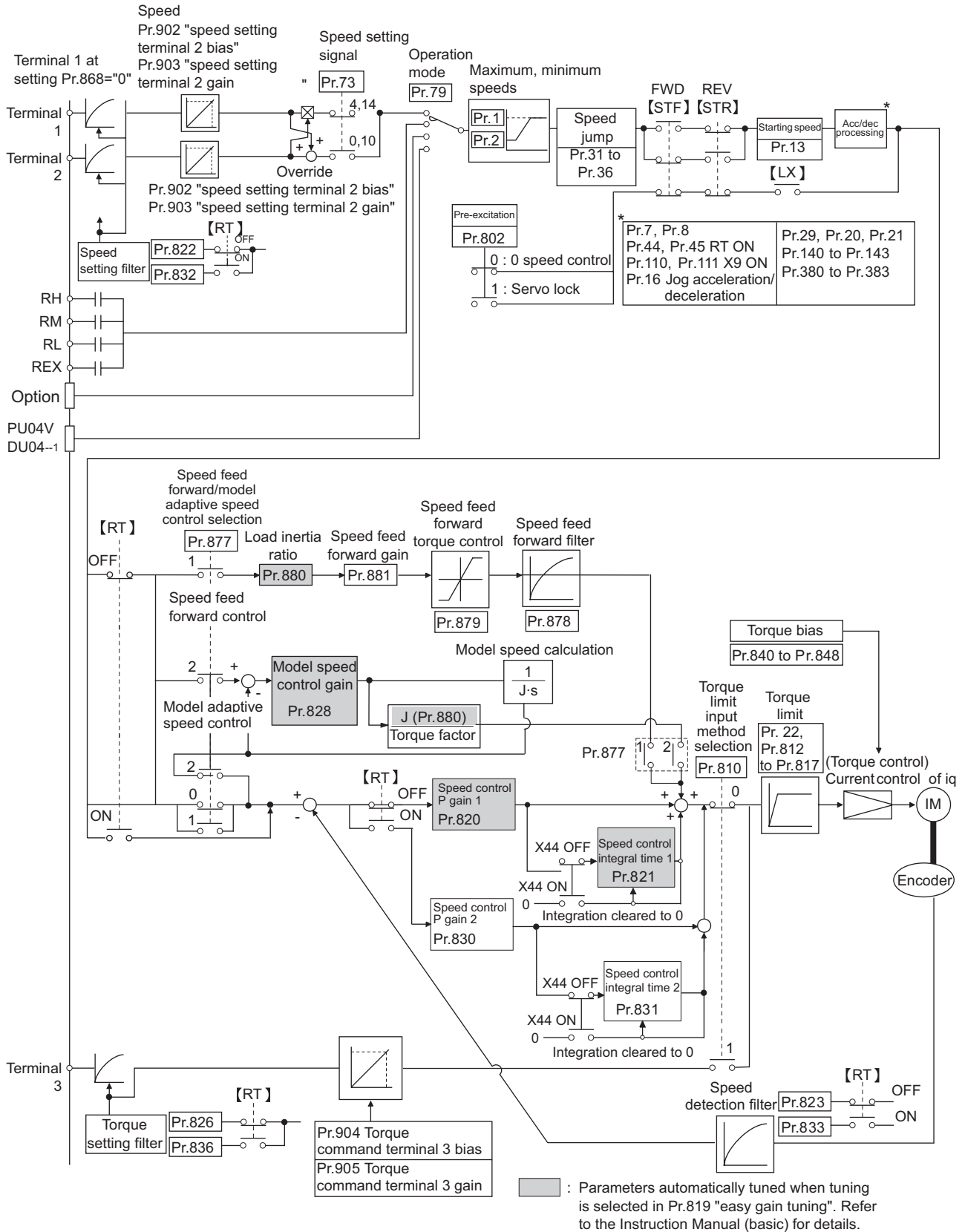

**2.3.2 Concept of adjustment of manual input speed control gains**

- 1) Speed control P gain 1
  - Pr. 820 = 60% is equivalent to 120rad/s (speed response of the motor alone). (factory setting)
  - Increasing the proportional gain increases the response level. However, a too high gain will produce vibration and/or unusual noise.
- 2) Speed control integral time
  - Pr. 821 = 0.333s (factory setting)
  - Decreasing the integral time shortens the return time taken at a speed change. However, a too short time will generate an overshoot.

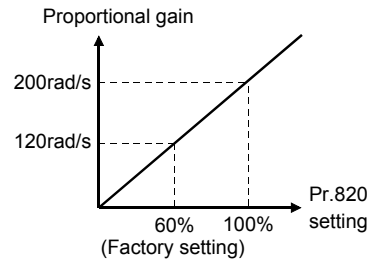

When there is load inertia, the actual speed gain decreases as given below.

Actual speed gain = speed gain of motor without load  $\times \frac{J_M}{J_M+J_L}$        $J_M$  : Inertia of motor  
 $J_L$  : Motor shaft-equivalent load inertia

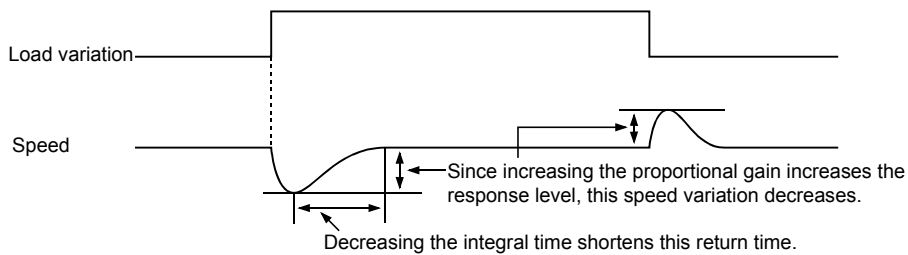

**2.3.3 Speed control gain adjustment procedure (Pr. 820, Pr. 821)**

- Set "0" in Pr. 819 "easy gain tuning". (Easy gain tuning is not performed.)
- Refer to the Instruction Manual (basic) for easy gain tuning.
- Refer to the following for manually input gain adjustment.

**Manual input gain adjustment**

- Pr. 820 "speed control P (proportional) gain 1", Pr. 830 "speed control P (proportional) gain 2"
  - Pr. 821 "speed control integral time 1", Pr. 831 "speed control integral time 2"
- Make adjustment when any of such phenomena as unusual machine vibration/noise, low response level and overshoot has occurred.
- 1) First check the conditions and simultaneously change Pr. 820 "speed control P gain 1" value.
  - 2) If you cannot make proper adjustment, change Pr. 821 "speed control integral time 1" value and repeat step (1).

**CAUTION**

Pr. 830 "speed control P(proportional) gain 2" and Pr. 831 "speed control integral time 2" are made valid when the RT terminal is switched on. Make adjustments in the same way as Pr. 820 and Pr. 821.

No.	Phenomenon/Condition	Adjustment Method
1	Large load inertia	Set the Pr. 820 and Pr. 821 values a little higher.
		Pr. 820    When a speed rise is slow, increase the value 10% by 10% until just before vibration/noise is produced, and set about 0.8 to 0.9 of that value.
		Pr. 821    If an overshoot occurs, double the value until an overshoot does not occur, and set about 0.8 to 0.9 of that value.
2	Vibration/noise generated from mechanical system	Set the Pr. 820 value a little lower and the Pr. 821 value a little higher.
		Pr. 820    Decrease the value 10% by 10% until just before vibration/noise is not produced, and set about 0.8 to 0.9 of that value.
		Pr. 821    If an overshoot occurs, double the value until an overshoot does not occur, and set about 0.8 to 0.9 of that value.
3	Slow response	Set the Pr. 820 value a little higher.
		Pr. 820    When a speed rise is slow, increase the value 5% by 5% until just before vibration/noise is produced, and set about 0.8 to 0.9 of that value.

No.	Phenomenon/Condition	Adjustment Method
4	Long return time (response time)	Set the Pr. 821 value a little lower.
		Decrease the value by half until just before an overshoot or the unstable phenomenon does not occur, and set about 0.8 to 0.9 of that value.
5	Overshoot or unstable phenomenon occurs.	Set the Pr. 821 value a little higher.
		Double the value until just before an overshoot or the unstable phenomenon does not occur, and set about 0.8 to 0.9 of that value.

**REMARKS**

You can switch between PI control and P control under speed control using the X44 signal. (Refer to page 34.)

**2.3.4 Troubleshooting**

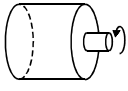
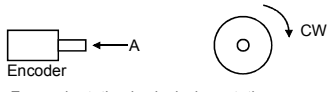
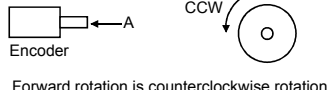
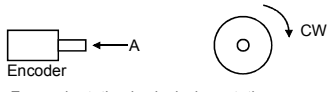
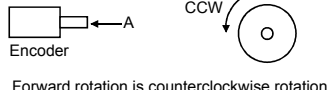
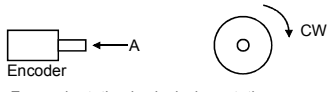
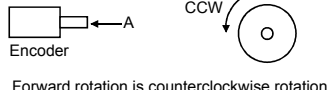
	Phenomenon	Cause	Corrective Action						
1	Motor does not rotate.	(1) The motor or encoder wiring is wrong.	<p>(1) Check the wiring. * Choose V/F control (Pr. 800 = 20) and check the rotation direction of the motor and the speed monitor output from the DA1 output terminal. For the FR-V5RU, set "170V" for 3.7kW or less and "160V" for more in Pr. 19 "base frequency voltage", and set "50Hz" in Pr. 3 "base frequency".</p> <p>When the forward rotation signal is input, the motor running in the counterclockwise direction as viewed from the motor shaft is normal. (If it runs in the clockwise direction, the phase sequence of the inverter secondary side wiring is incorrect.)</p>  <p>(2) Check the encoder specifications. Check the positions of the 5V/12V/24V/External and differential/complimentary jumper connectors.</p> <p>(3) Check that FWD is displayed when running the motor in the counter-clockwise direction from outside during a stop of the inverter. If REV is displayed, the encoder phase sequence is wrong. Perform the correct wiring or match the Pr. 852 "encoder rotation direction" setting.</p> <table border="1" style="width: 100%; border-collapse: collapse;"> <thead> <tr> <th style="width: 15%;">Pr. 852 Setting</th> <th>Relationship between the motor and encoder</th> </tr> </thead> <tbody> <tr> <td style="text-align: center;">0</td> <td>  <p>Forward rotation is clockwise rotation when viewed from A.</p> </td> </tr> <tr> <td style="text-align: center;">1 (factory setting)</td> <td>  <p>Forward rotation is counterclockwise rotation when viewed from A.</p> </td> </tr> </tbody> </table>	Pr. 852 Setting	Relationship between the motor and encoder	0	 <p>Forward rotation is clockwise rotation when viewed from A.</p>	1 (factory setting)	 <p>Forward rotation is counterclockwise rotation when viewed from A.</p>
		Pr. 852 Setting		Relationship between the motor and encoder					
0	 <p>Forward rotation is clockwise rotation when viewed from A.</p>								
1 (factory setting)	 <p>Forward rotation is counterclockwise rotation when viewed from A.</p>								
(2) The encoder specifications (jumper connector setting) are wrong.									
(3) The encoder wiring is wrong.	(4) The Pr. 851 "number of encoder pulses" setting and the number of encoder used are different.	(4) The motor will not run if the parameter setting is smaller than the number of encoder pulses used. Set Pr. 851 "number of encoder pulses" correctly.							
2	Motor does not run at correct speed. (Speed command does not match actual speed)	<p>(1) The speed command from the command device is incorrect. The speed command is compounded with noise.</p> <p>(2) The speed command value does not match the inverter-recognized value.</p> <p>(3) The number of encoder pulses setting is incorrect.</p>	<p>(1) Check that a correct speed command comes from the command device. Decrease the PWM carrier frequency in Pr. 72.</p> <p>(2) Readjust the speed command bias and gain in Pr. 902, Pr. 903, Pr. 917, and Pr. 918.</p> <p>(3) Check the setting of the number of encoder pulses in Pr. 851.</p>						



## Fine adjustment of gains for speed control

	Phenomenon	Cause	Corrective Action
3	Speed does not rise to the speed command.	(1) Insufficient torque. Torque limit is actuated.  (2) Only P (proportional) control is selected.	(1)-1 Increase the torque limit value. (Refer to the torque limit of speed control in the Instruction Manual (basic).) (1)-2 Insufficient capacity (2) When the load is heavy, speed deviation will occur under P (proportional) control. Select PI control.
4	Motor speed is unstable.	(1) The speed command varies.  (2) Insufficient torque.  (3) The speed control gains do not match the machine. (mechanical resonance)	(1)-1 Check that a correct speed command comes from the command device. (Take measures against noises.) (1)-2 Decrease the PWM carrier frequency in Pr. 72. (1)-3 Increase the speed setting filter in Pr. 822. (2)-1 Increase the torque limit value. (Refer to the torque limit of speed control in the Instruction Manual (basic).) (2)-2 Return the excitation ratio in Pr. 854 to the factory setting (100%). (3)-1 Perform easy gain tuning. (3)-2 Adjust Pr. 820 and Pr. 821. (Refer to gain adjustment.) (3)-3 Perform speed feed forward control and model adaptive speed control.
5	Motor or machine hunts (vibration/noise is produced).	(1) The speed control gain is high.  (2) High torque control gain. (3) Motor wiring and encoder wiring are not correct.	(1)-1 Perform easy gain tuning. (1)-2 Decrease Pr. 820 and increase Pr. 821. (1)-3 Perform speed feed forward control and model adaptive speed control. (2) Decrease Pr. 824. (Refer to page 53.) (3) Check wiring. Check Pr. 852 setting for the encoder rotation direction.
6	Acceleration/ deceleration time does not match the setting.	(1) Insufficient torque.  (2) Large load inertia.	(1)-1 Increase the torque limit value. (Refer to the torque limit of speed control in the Instruction Manual (basic).) (1)-2 Return the excitation ratio in Pr. 854 to the factory setting. (1)-3 Perform speed feed forward control. (2) Set the acceleration/deceleration time that meets the load.
7	Machine operation is unstable	(1) The speed control gains do not match the machine.  (2) Slow response because of improper acceleration/ deceleration time of the inverter.	(1)-1 Perform easy gain tuning. (1)-2 Adjust Pr. 820 and Pr. 821. (Refer to page 46.) (1)-3 Perform speed feed forward control and model adaptive speed control. (2) Change the acceleration/deceleration time to an optimum value.
8	Speed fluctuates at low speed.	(1) Adverse effect of high carrier frequency. (2) Adverse effect of weak excitation. (3) Low speed control gain.	(1) Decrease the PWM carrier frequency in Pr. 72. (2) Return the excitation ratio in Pr. 854 to the factory setting. (3) Increase Pr. 820 "speed control P gain".

### Related parameter reference pages

- Pr. 71 "applied motor" (Refer to page 111.)
- Pr. 72 "PWM frequency selection" (Refer to page 112.)
- Pr. 800 "control system selection" (Refer to page 169.)
- Pr. 820 "speed control P gain 1" (Refer to page 175.)
- Pr. 821 "speed control integral time 1" (Refer to page 175.)
- Pr. 822 "speed setting filter 1" (Refer to page 175.)
- Pr. 851 "number of encoder pulses" (Refer to the Instruction Manual (basic).)
- Pr. 854 "excitation ratio" (Refer to page 181.)
- Pr. 902 "speed setting terminal 2 bias" (Refer to page 190.)
- Pr. 903 "speed setting terminal 2 gain" (Refer to page 190.)
- Pr. 917 "terminal 1 bias (speed)" (Refer to page 190.)
- Pr. 918 "terminal 1 gain (speed)" (Refer to page 190.)

### 2.3.5 Speed feed forward control, model adaptive speed control (Pr. 828, Pr. 877 to Pr. 881)

By making parameter setting, select the speed feed forward control or model adaptive speed control. The speed feed forward control enhances the trackability of the motor in response to a speed command change. The model adaptive speed control enables individual adjustment of speed trackability and motor disturbance torque response.

Parameter	Name	Factory Setting	Setting Range
828	Model speed control gain	60%	0 to 1000%
877	Speed feed forward control/model adaptive speed control selection	0	0,1,2
878	Speed feed forward filter	0s	0 to 1s
879	Speed feed forward torque limit	150%	0 to 400%
880	Load inertia ratio	7	0,1 to 200 times
881	Speed feed forward gain	0%	0 to 1000%

**POINT**

When model adaptive speed gain is selected, the data obtained from easy gain tuning is used for Pr. 828 "model speed control proportional gain". Perform easy gain tuning also (simultaneously). (Refer to the Instruction Manual (basic).)

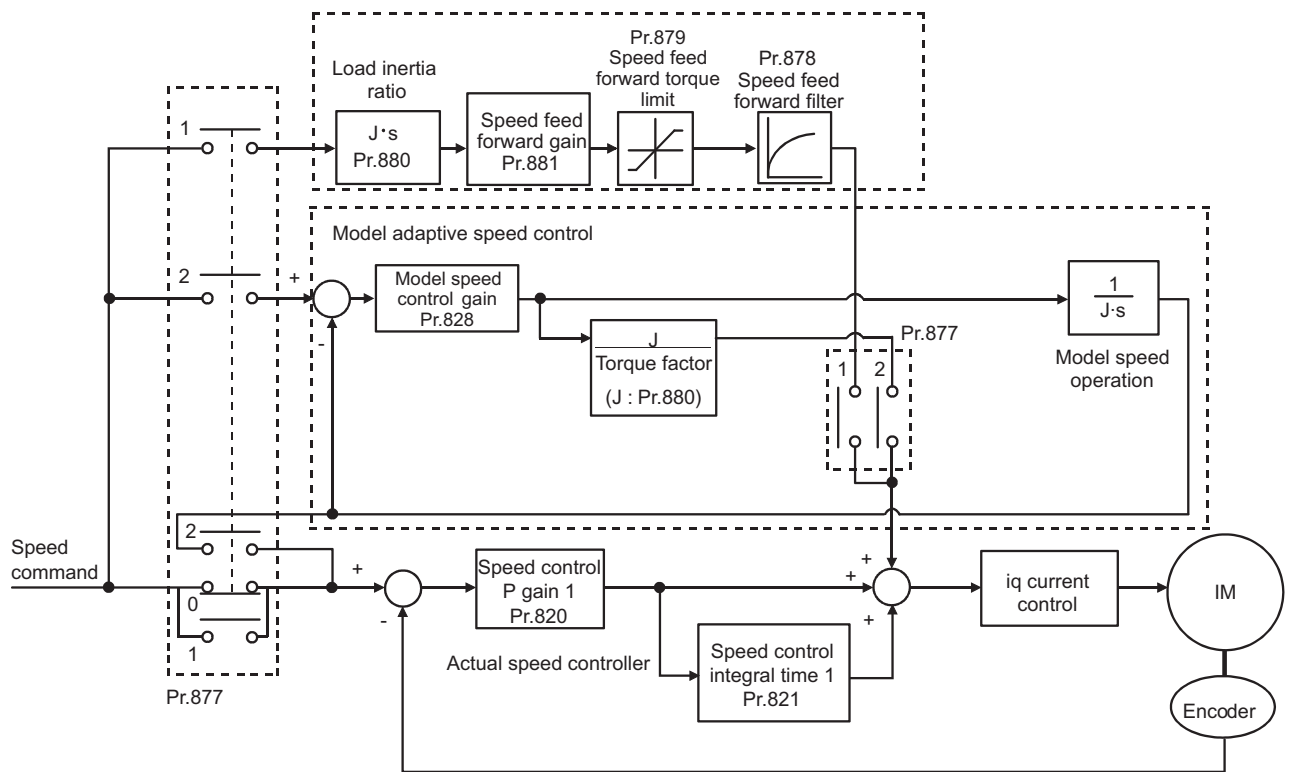

## Fine adjustment of gains for speed control

Pr. 877 Setting	Description
0	Normal speed control is exercised.
1	Speed feed forward control is exercised. ① Calculate required torque in response to the acceleration/deceleration command for the inertia ratio set in Pr. 880 and generate torque immediately. ② When inertia ratio estimation has been made by easy gain tuning, the inertia ratio estimation result is used as the Pr. 880 setting, from which the speed feed forward is calculated. ③ When the speed feed forward gain is 100%, the calculation result of the speed feed forward in 1) is reflected as-is. ④ If the speed command changes suddenly, large torque is generated due to the speed feed forward calculation. The maximum value of the speed feed forward is restricted using Pr. 879. ⑤ Using Pr. 878, the speed feed forward result can be dulled by the primary delay filter.
2	Model adaptive speed control is enabled. • At this time, the motor's model speed is calculated to feed back the model side speed controller. This model speed is also used as the actual speed controller command. • The inertia ratio in Pr. 880 is used for calculation of the torque current command value given by the model side speed controller. When inertia ratio estimation has been made by easy gain tuning, Pr. 880 is overwritten by the inertia ratio estimation result, and that value is used to calculate the torque current command value. • The torque current command value of the model side speed controller is added to the output of the actual speed controller, and the result is used as the iq current control input. Pr. 828 is used for model side speed control (P control), and the first gain in Pr. 820 is used for the actual speed controller. The model adaptive speed control is valid for the first motor only. • When Pr. 877 = 2, switching to the second motor handles the second motor as Pr. 877 = 0.

### CAUTION

**The adequate gain value for the model and actual loop parts are set according to the response setting of easy gain tuning under model adaptive speed control. To increase the response level, Pr. 818 "response setting" needs to be changed (increased).**

The following table indicates the relationships between the speed feed forward control and easy gain tuning function.

	Easy Gain Tuning Selection (Pr. 819) Setting		
	0	1	2
Load inertia ratio (Pr. 880)	Manual input	Inertia ratio estimation value found by easy gain tuning is displayed. Manual input enabled only during a stop.	Manual input
Model speed control gain (Pr. 828)	Manual input	Tuning results are displayed. Write disabled.	Tuning results are displayed. Write disabled.
Speed feed forward gain (Pr. 881)	Manual input	Manual input	Manual input

### REMARKS

Calculate the inertia reference of the SF-V5RU (H) using the moment of inertia J on page 196.

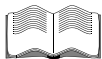

For details of easy gain tuning, refer to the Instruction Manual (basic) for details.

### Related parameters

- Pr. 820 "speed control P gain 1" (Refer to page 175.)
- Pr. 821 "speed control integral time 1" (Refer to page 175.)
- Pr. 830 "speed control P gain 2" (Refer to page 175.)
- Pr. 831 "speed control integral time 2" (Refer to page 175.)

## 2.4 Torque control

### 2.4.1 Outline of torque control

The basics of torque control are explained in the Instruction Manual (basic).

Set any of "1 (torque control), 2 (speed-torque switchover), 5 (position-torque switchover)" in Pr. 800 "control system selection" to make torque control valid.  
(The parameter is factory-set to enable speed control.) (Refer to page 169.)

Set the motor. (Refer to the Instruction Manual (basic).)

Set the torque command. (terminal 3)  
When using the parameter or communication to input the torque command, refer to Pr. 804 "torque command source selection" (page 171).  
When giving the torque command from the option (FR-A5NC, FR-V5AH, FR-A5AX, FR-V5AP), refer to the instruction manual of the corresponding option.

Set the speed limit value. (Refer to the Instruction Manual (basic))

**Test run**

Set online auto tuning (adaptive magnetic flux observer) as required.

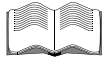

Refer to the Instruction Manual (basic) for the details of connection diagram, test run, and online auto tuning.

## 2.5 Fine adjustment for torque control

Current loop gain parameter for adjusting torque control operation state is available with the FR-V500 series. Stable operation is possible with the factory-set parameter.

Refer to the next page and adjust the parameters when torque pulsation or any other unfavorable phenomenon occurs depending on the machine and operating conditions or when you want to exhibit the best performance that matches the machine.

### 2.5.1 Control block diagram

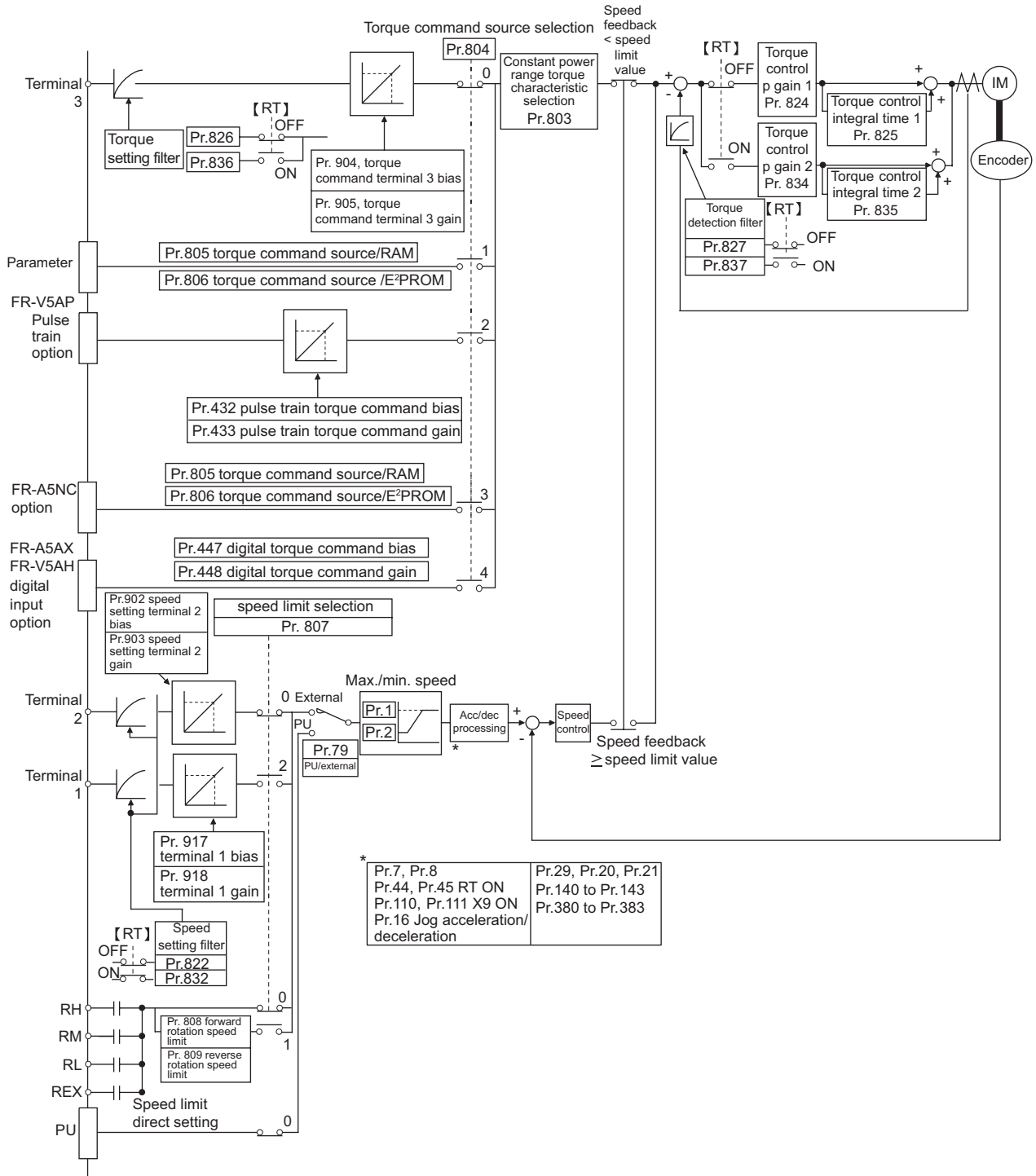

## 2.6 Gain adjustment for torque control

When exercising torque control, do not perform easy gain tuning. Easy gain tuning produces no effects. If torque accuracy is necessary, perform online auto tuning. (Refer to the Instruction Manual (basic).)

### 2.6.1 Concept of torque control gains

- (1) Torque control P gain 1  
2000rad/s when Pr. 824 = 100% (factory setting).
- (2) Torque control integral time 1  
Pr. 825 = 5ms (factory setting)

### 2.6.2 Gain adjustment procedure

Refer to the following table for manual input gain adjustment.

#### CAUTION

Normally, the current loop gains in Pr. 824 and Pr. 825 need not be changed. Fully note that unnecessarily changing the settings of the current loop gains will result in unstable phenomena and/or reduced response level.

#### ● Manual input gain adjustment

Pr. 824 "torque control P gain 1", Pr. 834 "torque control P gain 2"  
Pr. 825 "torque control integral time 1", Pr. 835 "torque control integral time 2"

Make adjustment when any of such phenomena as unusual machine vibration/noise and overcurrent has occurred.

- (1) First check the conditions and simultaneously change Pr. 824 "torque control P gain 1" value.
- (2) If you cannot make proper adjustment, change Pr. 825 "torque control integral time 1" value and repeat step (1).

#### CAUTION

Pr. 834 "torque control P gain 2" and Pr. 835 "torque control integral time 2" are made valid when the RT terminal is switched on. Make adjustments in the same way as Pr. 824 and Pr. 825.

No.	Phenomenon/Condition	Adjustment Method	
1	<ul style="list-style-type: none"> <li>• Unusual noise generated from motor</li> <li>• Unusual current flows</li> </ul>	Set Pr. 824 a little lower and Pr. 825 a little higher. First lower Pr. 824 and check the motor for unusual vibration/noise and overcurrent. If the problem still persists, increase Pr. 825.	
		Pr. 824	Decrease the value 10% by 10% until just before the phenomenon on the left is improved, and set about 0.8 to 0.9 of that value. Note that a too low value will produce current ripples, causing the motor to generate sound synchronizing the cycle of current ripples.
		Pr. 825	Double the value until just before the phenomenon on the left is improved, and set about 0.8 to 0.9 of that value. Note that a too high value will produce current ripples, causing the motor to generate sound synchronizing the cycle of current ripples.
2	Overcurrent occurs.	Set Pr. 824 a little lower and Pr. 825 a little higher. First lower Pr. 824 and check the motor for unusual vibration/noise and overcurrent. If the problem still persists, increase Pr. 825.	
		Pr. 824	Decrease the value 10% by 10% until just before an overcurrent does not occur, and set about 0.8 to 0.9 of that value.
		Pr. 825	Double the value until just before the phenomenon on the left is improved, and set about 0.8 to 0.9 of that value.

### 2.6.3 Troubleshooting

	Phenomenon	Cause	Corrective Action
1	Torque control is not exercised normally.	(1) The phase sequence of the motor or encoder wiring is wrong. (2) The control mode selection, Pr. 800, setting is improper. (3) The speed limit value is not input. (4) The torque command varies. (5) Torque variation due to the change in the motor temperature. (6) The torque command does not match the inverter-recognized value.	(1) Check the wiring. (Refer to the Instruction Manual (basic).) (2) Check the Pr. 800 setting. (The factory setting is speed control) (3) Set the speed limit value. (If the speed limit value is not input, the motor will not rotate since the speed limit value is regarded as 0r/min.) (4) Check that the command device gives a correct torque command. · Decrease the PWM carrier frequency in Pr. 72. · Increase the torque setting filter in Pr. 826. (5) Set the adaptive magnetic flux observer in Pr. 95. (6) Recalibrate the torque command bias and gain in Pr. 904 and Pr. 905.
2	When the torque command is small, the motor rotates in the direction opposite to the start signal.	The offset calibration of the torque command does not match.	Recalibrate the torque command bias in Pr. 904.
3	Normal torque control cannot be exercised during acceleration/deceleration. The motor vibrates.	Since the speed limit value changes with the setting of the acceleration/deceleration time in Pr. 7, Pr. 8, the speed limit may be activated. (When the speed limit is activated, torque control cannot be exercised.)	Reduce the acceleration/deceleration time. Alternatively, set the acceleration/deceleration time to 0. (Speed limit during acceleration/deceleration is speed limit during constant speed)
4	Output torque is not linear in response to the torque command.	Insufficient torque.	Return the excitation ratio to the factory setting.

#### Related parameter reference pages

- Pr. 7 "acceleration time" (Refer to page 78.)
- Pr. 8 "deceleration time" (Refer to page 78.)
- Pr. 800 "control system selection" (Refer to page 169.)
- Pr. 802 "pre-excitation selection" (Refer to page 82.)
- Pr. 810 "torque limit input method selection" (Refer to page 87.)
- Pr. 826 "torque setting filter 1" (Refer to page 176.)
- Pr. 904 "torque command terminal 3 bias" (Refer to page 190.)
- Pr. 905 "torque command terminal 3 gain" (Refer to page 190.)

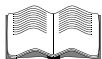

For online auto tuning, refer to the Instruction Manual (basic)

## 2.7 Position control (Pr. 419 to Pr. 430, Pr. 464 to Pr. 494)

### 2.7.1 Connection diagram

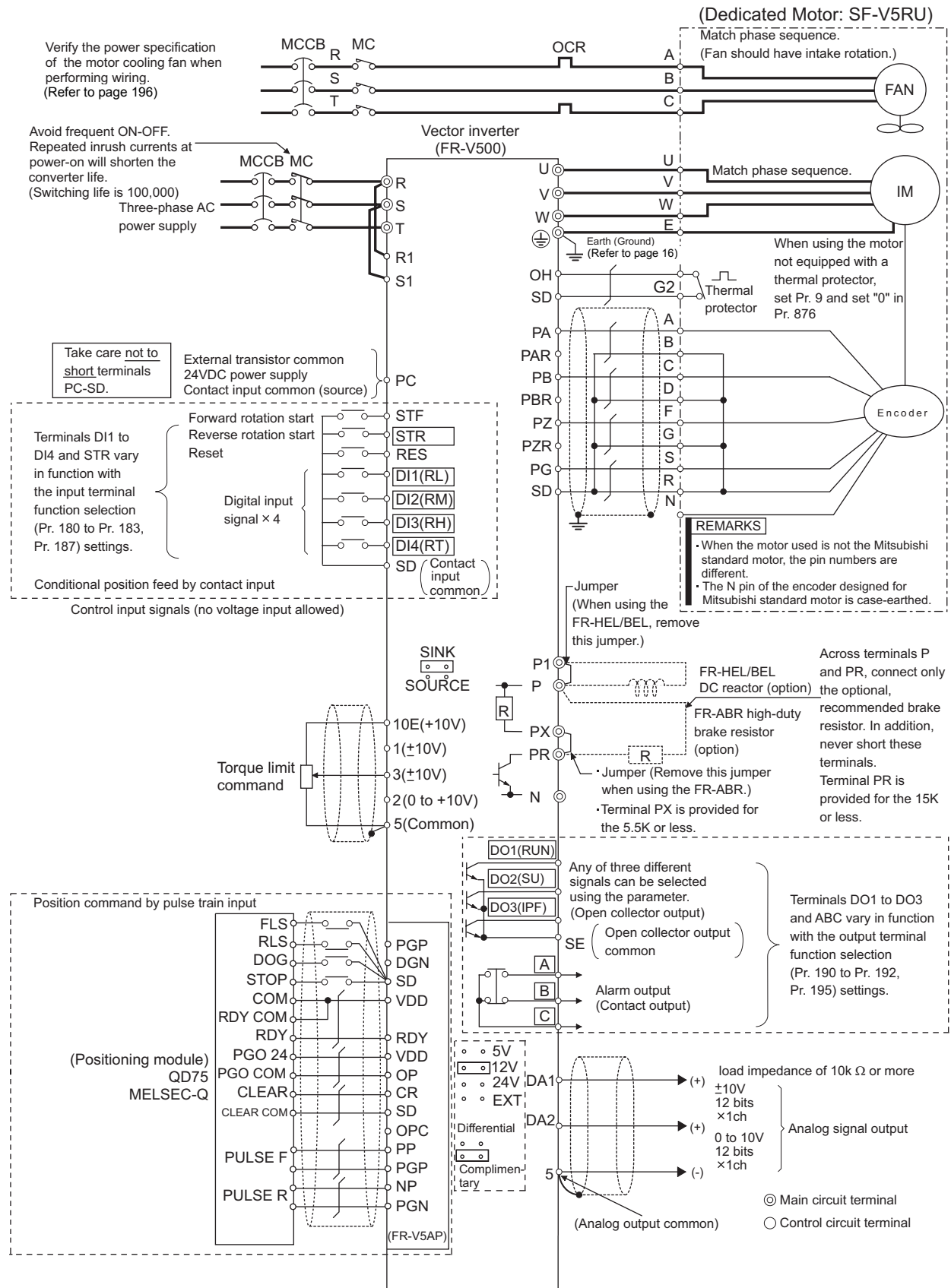

#### REMARKS

Refer to the Instruction Manual (basic) for the terminal function change when the mode has been changed to the position control mode.



**Position control (Pr. 419 to Pr. 430,  
Pr. 464 to Pr. 494)**

This inverter is allowed to perform position control by setting conditional position feed by contact input or the position control option (FR-V5AP, FR-V5NS). And the position loop gain that adjusts this position control status is provided for the inverter. It is not used independently but is used with the speed loop parameter to determine the value. Therefore, first adjust the speed loop gain and then adjust the position loop gain parameter.

**2.7.2 Position control step**

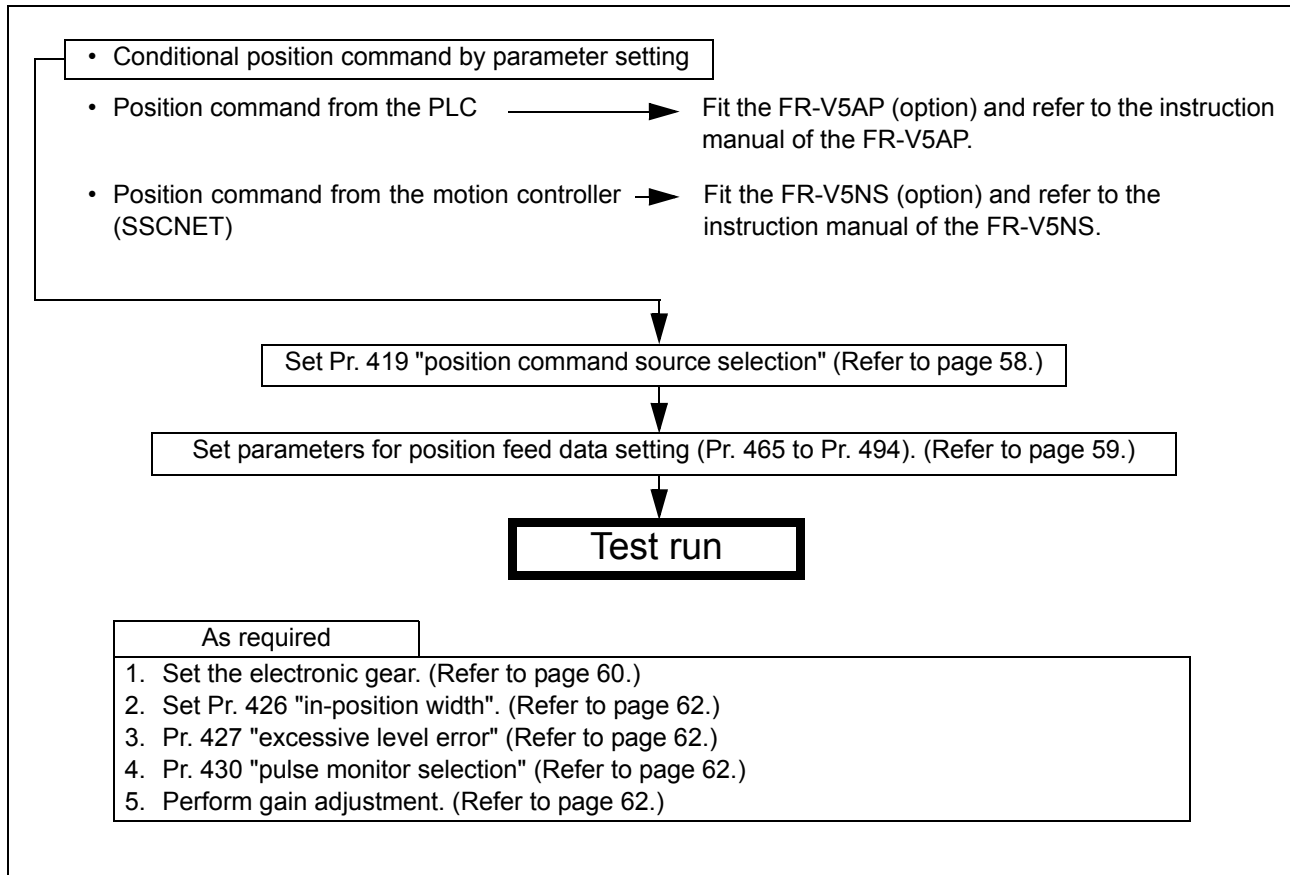

### 2.7.3 Control block diagram

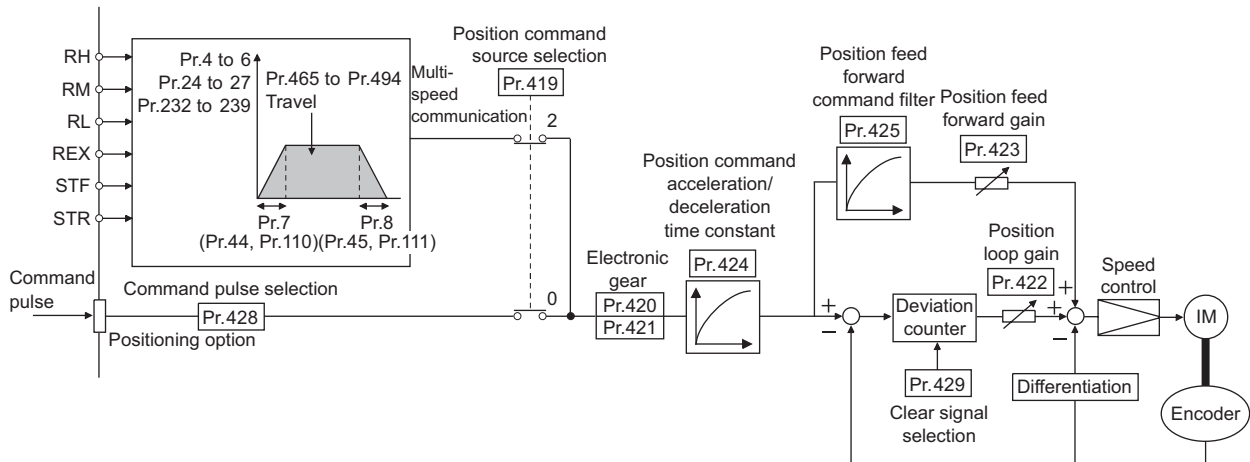

### 2.7.4 Parameter

Set the following parameters when exercising position control with the inverter.

Parameter	Name	Factory Setting	Setting Range	Description	Refer To
419	Position command source selection	0	0, 1	Set position command input.	58
420	Command pulse scaling factor numerator	1	0 to 32767	Set the electronic gear.	60
421	Command pulse scaling factor denominator	1	0 to 32767		
422	Position loop gain	25	0 to 150s <sup>-1</sup>	Set the gain of the position loop.	62
423	Position feed forward gain	0%	0 to 100%	Function to cancel a delay caused by the droop pulses of the deviation counter.	62
424	Position command acceleration/deceleration time constant	0s	0 to 50s		61
425	Position feed forward command filter	0s	0 to 5s	Enter the primary delay filter in response to the feed forward command.	
426	In-position width	100 pulses	0 to 32767 pulses	The in-position signal turns on when the droop pulses become less than the setting.	62
427	Excessive level error	40K	0 to 400K, 9999	An error becomes excessive when the droop pulses exceed the setting.	62
430	Pulse monitor selection	9999	0 to 5, 9999	Display the number of pulses.	62
464	Digital position control sudden stop deceleration time	0	0 to 360.0s		60

**(1) Position command source selection (Pr. 419)**

Pr. 419 Setting	Description
0 (factory setting)	Position control function by contact input. (using parameters)
1	Position command by pulse train input (when the FR-V5AP is fitted). (Refer to the instruction manual of the option for details.)

**(2) Operation**

The speed command given to rotate the motor is calculated to zero the difference between the number of internal command pulse train pulses (when Pr. 419 = 0, the number of pulses set by parameter (Pr. 465 to Pr. 494) is changed to the command pulses in the inverter) and the number of pulses fed back from the motor end encoder.

- 1) When a pulse train is input, pulses are accumulated in the deviation counter and these droop pulses act as position control pulses to give the speed command.
- 2) As soon as the motor starts running under the speed command of the inverter, the encoder generates feed back pulses and the droop of the deviation counter is counted down. The deviation counter maintains a given droop pulse value to keep the motor running.
- 3) When the command pulse input stops, the droop pulses of the deviation counter decrease, reducing the speed. The motor stops when there are no droop pulses.
- 4) When the number of droop pulses has fallen below the value set in Pr.426 (in-position width), it is regarded as completion of positioning and the in-position signal (Y36) turns on.

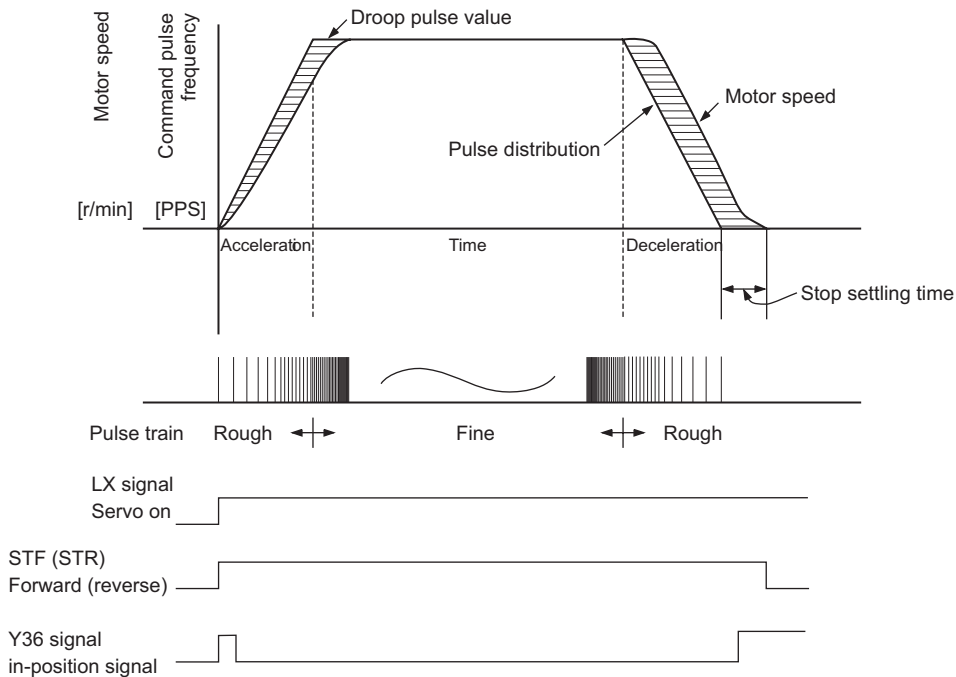

- For position control function by contact input, the STF and STR terminals provide the forward (reverse) command signal. The motor can run only in the direction where the forward (reverse) signal is on.
- Opening STF-SD disables the forward rotation, and opening STR-SD disables the reverse rotation.
- The pulse train is rough during acceleration and fine at the maximum speed. During deceleration the pulse train is rough and at last there are no pulses. The motor stops shortly after the command pulses stop. This time lag is necessary for maintaining the stop accuracy and called stop setting time.

**Related parameters**

- Servo on signal (LX) ⇒ Set "23" in any of Pr. 180 to Pr. 183 and Pr. 187 (input terminal function selection). (Refer to page 150.)
- In-position signal (Y36) ⇒ Set "36" in any of Pr.190 to Pr.192 and Pr.195 (output terminal function selection). (Refer to page 152.)

## 2.7.5 Conditional position feed function by contact input (Pr. 419 = 0)

Inputting the number of pulses (positions) in the parameters and setting multi-speed and forward (reverse) commands enable position control during servo operation. This position feed function does not return to the home position.

### (1) Setting position command using parameters

Set position command using any two of Pr. 465 to Pr. 494 (position feed amount).

Resolution of encoder × speed × 4

↓  
(When stopping the motor after 100 rotations using the SF-V5RU)  
2048 (pulse/rev) × 100 (speed) × 4 = 819200 (feed amount)

Setting the first amount 819200

Pr. 466 (upper digits)=          Pr. 465 (lower digits)=          (decimal numeration)

<Position feed data setting parameters>

- Factory setting : 0
- Setting range : 0 to 9999
- Minimum setting range : 1

Parameter	Name	Selection Method				Position Feed Speed	
		REX	RH	RM	RL		
465	First position feed amount	(lower digits)	OFF	ON	OFF	OFF	High speed, Pr. 4
466		(upper digits)					
467	Second position feed amount	(lower digits)	OFF	OFF	ON	OFF	Middle speed, Pr. 5
468		(upper digits)					
469	Third position feed amount	(lower digits)	OFF	OFF	OFF	ON	Low speed, Pr. 6
470		(upper digits)					
471	Fourth position feed amount	(lower digits)	OFF	OFF	ON	ON	Speed 4, Pr. 24
472		(upper digits)					
473	Fifth position feed amount	(lower digits)	OFF	ON	OFF	ON	Speed 5, Pr. 25
474		(upper digits)					
475	Sixth position feed amount	(lower digits)	OFF	ON	ON	OFF	Speed 6, Pr. 26
476		(upper digits)					
477	Seventh position feed amount	(lower digits)	OFF	ON	ON	ON	Speed 7, Pr. 27
478		(upper digits)					
479	Eighth position feed amount	(lower digits)	ON	OFF	OFF	OFF	Speed 8, Pr. 232
480		(upper digits)					
481	Ninth position feed amount	(lower digits)	ON	OFF	OFF	ON	Speed 9, Pr. 233
482		(upper digits)					
483	Tenth position feed amount	(lower digits)	ON	OFF	ON	OFF	Speed 10, Pr. 234
484		(upper digits)					
485	Eleventh position feed amount	(lower digits)	ON	OFF	ON	ON	Speed 11, Pr. 235
486		(upper digits)					
487	Twelfth position feed amount	(lower digits)	ON	ON	OFF	OFF	Speed 12, Pr. 236
488		(upper digits)					
489	Thirteenth position feed amount	(lower digits)	ON	ON	OFF	ON	Speed 13, Pr. 237
490		(upper digits)					
491	Fourteenth position feed amount	(lower digits)	ON	ON	ON	OFF	Speed 14, Pr. 238
492		(upper digits)					
493	Fifteenth position feed amount	(lower digits)	ON	ON	ON	ON	Speed 15, Pr. 239
494		(upper digits)					

**(2) Operation by position command using parameters**

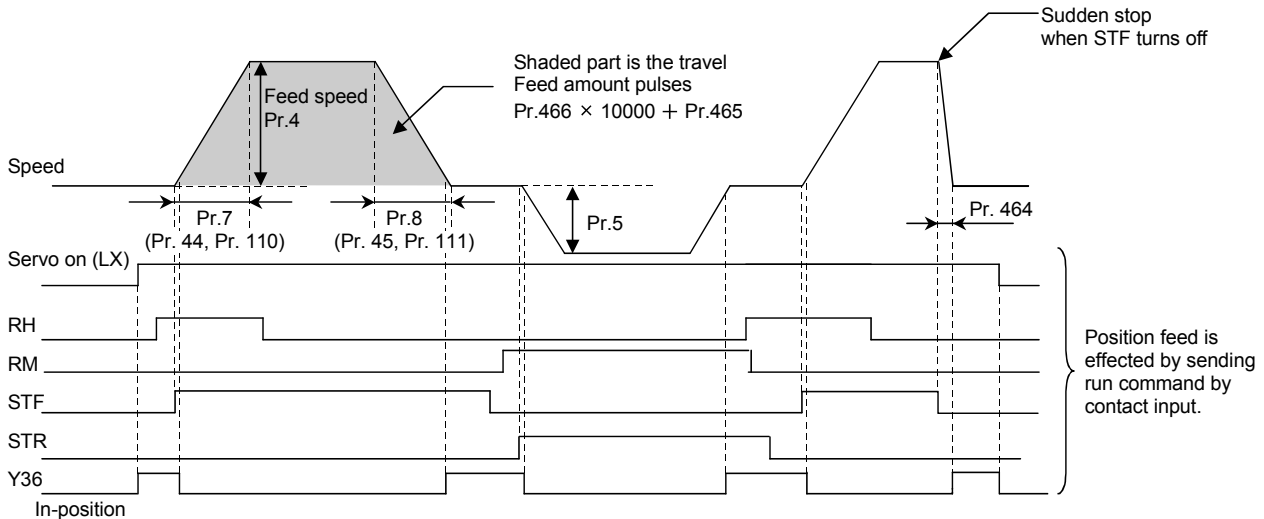

- Acceleration/deceleration time is 0.1s minimum and 360s maximum.
- Acceleration/deceleration reference speed (Pr. 20) is clamped at a minimum of 500r/min.
- Deceleration time can be set in Pr. 464 "digital position control sudden stop deceleration time".
- At this time, the acceleration/deceleration patterns are all linear acceleration and the setting of Pr. 29 "acceleration/deceleration pattern" is invalid. (Refer to page 89 for Pr. 29.)

**CAUTION**

Information on multi-speed command (position command) is determined at rising of the forward (reverse) command to perform position control.  
Therefore, set forward (reverse) command after multi-speed command (position command).  
Position feed is invalid if the multi-speed command is given after forward (reverse) command.

**2.7.6 Setting the electronic gear**

Adjust the ratio of the machine side gear and the motor side gear.

The position resolution (travel per pulse  $\Delta l$  [mm]) is determined by the travel per motor revolution  $\Delta s$  [mm] and the feedback pulses Pf [pulse/rev] of the detector, and is represented by the following expression.

$$\Delta l = \frac{\Delta s}{Pf}$$

$\Delta l$ : Travel per pulse [mm]  
 $\Delta s$ : Travel per motor revolution [mm]  
 Pf: Number of feedback pulses [pulse/rev]  
 (the number of pulses after multiplying the number of encoder pulses by 4)

Using the parameters, the travel per command pulse can be set separately to set the travel per command pulse without a fraction.

$$\Delta l = \frac{\Delta s}{Pf} \times \frac{Pr. 420}{Pr. 421}$$

The relationship between the motor speed and internal command pulse frequency is as follows.

$$fo \times \frac{Pr. 420}{Pr. 421} = Pf \times \frac{No}{60}$$

$fo$ : Internal command pulse frequency [pps]  
 $No$ : Motor speed [r/min]

**CAUTION**

Set the electronic gear in the range of 1/50 to 20.  
For products manufactured in July 2003 and thereafter, the electronic gear will function within the range of 1/900 to 900. However, it is recommended to use the electronic gear within the range of 1/50 to 20. Note that too small a value will decrease the speed command and too large a value will increase the speed ripples. Check the rating plate for the month when the inverter was manufactured. (Refer to page 220.)

"Setting example 1"

The travel per pulse is  $\Delta \ell = 0.01$  (mm) in a drive system where the ballscrew pitch  $PB = 10$  (mm) and the reduction ratio  $1/n = 1$  and the electronic gear ratio is  $\Delta s = 10$  (mm) when the number of feedback pulses  $Pf = 4000$  (pulse/rev). According to the following expression,

$$\begin{aligned} \Delta \ell &= \frac{\Delta s}{Pf} \times \frac{\text{Pr. 420}}{\text{Pr. 421}} \\ \frac{\text{Pr. 420}}{\text{Pr. 421}} &= \Delta \ell \times \frac{Pf}{\Delta s} \\ &= 0.01 \times \frac{4000}{10} = \frac{4}{1} \end{aligned}$$

Therefore, set "4" in Pr. 420 and "1" in Pr. 421.

"Setting example 2"

Find the internal command pulse frequency of the dedicated motor rated speed.

Note that the command pulse scaling factor  $\text{Pr. 420}/\text{Pr. 421} = 1$ .

Assuming that the number of encoder pulses is 2048 (pulses/rev) (feedback pulse  $Pf = 2048 \times 4$ ),

$$\begin{aligned} f_o &= 2048 \times \frac{N_o}{60} \times \frac{\text{Pr. 421}}{\text{Pr. 420}} \times 4 \\ &= 204800 \end{aligned}$$

Therefore, the internal command pulse frequency is 204800 (pps).

<Relationship between position resolution  $\Delta \ell$  and overall accuracy>

Since overall accuracy (positioning accuracy of machine) is the sum of electrical error and mechanical error, normally take measures to prevent the electrical system error from affecting the overall error. As a guideline, refer to the following relationship.

$$\Delta \ell < \left( \frac{1}{5} \text{ to } \frac{1}{10} \right) \times \Delta \varepsilon \quad \Delta \varepsilon : \text{Positioning accuracy}$$

<Stopping characteristic of motor>

When parameters are used to run the motor, the command pulse frequency and motor speed have the relationship as shown in the chart on page 58, and as the motor speed decreases, pulses are accumulated in the deviation counter of the inverter. These pulses are called droop pulses ( $\varepsilon$ ) and the relationship between command frequency ( $f_o$ ) and position loop gain ( $K_p$ : Pr. 422) is as represented by the following expression.

$$\varepsilon = \frac{f_o}{K_p} \text{ [pulse]} \quad \varepsilon = \frac{204800}{25} \text{ [pulse]} \quad (\text{motor rated speed})$$

When the factory setting of  $K_p$  is  $25s^{-1}$ , the droop pulses ( $\varepsilon$ ) are 8192 pulses.

Since the inverter has droop pulses during running, a stop settling time ( $t_s$ ) is needed from when the command has zeroed until the motor stops. Set the operation pattern in consideration of the stop settling time.

$$t_s = 3 \times \frac{1}{K_p} \text{ [s]}$$

When the factory setting of  $K_p$  is  $25s^{-1}$ , the stop settling time ( $t_s$ ) is 0.12s.

The positioning accuracy  $\Delta \varepsilon$  is  $(5 \text{ to } 10) \times \Delta \ell = \Delta \varepsilon$  [mm]

● **Position command acceleration/deceleration time constant (Pr. 424)**

- 1) When the electronic gear ratio is large (about 10 or more times) and the speed is low, rotation will not be smooth, resulting in pulse-wise rotation. At such a time, set this parameter to smooth the rotation.
- 2) When acceleration/deceleration time cannot be provided for the command pulses, a sudden change in command pulse frequency may cause an overshoot or error excess alarm. At such a time, set this parameter to provide acceleration/deceleration time.  
Normally set 0.

### 2.7.7 In-position width (Pr. 426)

The Y36 terminal signal acts as an in-position signal. The in-position signal turns on when the number of droop pulses becomes less than the setting.

### 2.7.8 Excessive level error (Pr. 427)

A position error becomes excessive when the droop pulses exceed the Pr. 427 setting. Error (E.OD) is displayed and the motor stops.

When you decreased the position loop gain (Pr. 422) setting, increase the error excessive level setting.

Also decrease the setting when you want to detect an error slightly earlier under large load.

When Pr. 472="9999", an excessive position error (E.OD) is not output regardless of the droop pulses.

Parameter	Name	Factory Setting	Setting Range	Remarks
427	Excessive level error	40	0 to 400, 9999	9999: function invalid

### 2.7.9 Pulse monitor selection (Pr. 430)

The states of various pulses during operation are displayed in terms of the number of pulses.

Set "6" in Pr. 52 "DU/PU main display data selection" to display output frequency monitor.

Pr. 430	Description	Display Range (FR-DU04-1)	Display Range (FR-PU04V)
0	The cumulative command pulse value is displayed.	Lower 4 digits	Lower 5 digits
1		Upper 4 digits	Upper 5 digits
2	The cumulative feedback pulse value is displayed.	Lower 4 digits	Lower 5 digits
3		Upper 4 digits	Upper 5 digits
4	The droop pulses are monitored.	Lower 4 digits	Lower 5 digits
5		Upper 4 digits	Upper 5 digits
9999	The frequency monitor is displayed. (factory setting)		

#### REMARKS

- Count the number of pulses when the servo is on.
- The cumulative pulse value is cleared when the base is shut off or the clear signal is turned on.

#### Related parameters

Pr. 52 "DU/PU main display data selection" (Refer to page 97.)

### 2.7.10 Concept of position control gains

Easy gain tuning is available as an easy tuning method. For easy gain tuning, refer to the Instruction Manual (basic). If it does not produce any effect, make fine adjustment by using the following parameters. Set "0" in Pr. 819 "easy gain tuning" before setting the parameters below.

#### (1) Pr. 422 "position loop gain" (factory setting 25s<sup>-1</sup>)

Make adjustment when any of such phenomena as unusual vibration, noise and overcurrent of the motor/machine occurs.

Increasing the setting improves trackability for the position command and also improves servo rigidity at a stop, but oppositely makes an overshoot and vibration more liable to occur. Normally set this parameter within the range about 5 to 50.

No.	Phenomenon/Condition	Adjustment Method	
1	Slow response	Increase the Pr. 422 value.	
		Pr. 422	Increase the value 3s <sup>-1</sup> by 3s <sup>-1</sup> until just before an overshoot, stop-time vibration or other instable phenomenon occurs, and set about 0.8 to 0.9 of that value.
2	Overshoot, stop-time vibration or other instable phenomenon occurs.	Decrease the Pr. 422 value.	
		Pr. 824	Decrease the value 3s <sup>-1</sup> by 3s <sup>-1</sup> until just before an overshoot, stop-time vibration or other instable phenomenon occurs, and set about 0.8 to 0.9 of that value.

#### (2) Pr. 423 "position feed forward gain" (factory setting 0)

This function is designed to cancel a delay caused by the droop pulses of the deviation counter.

When a tracking delay for command pulses poses a problem, increase the setting gradually and use this parameter within the range where an overshoot or vibration will not occur.

This function has no effects on servo rigidity at a stop.

Normally set this parameter to 0.

## 2.7.11 Troubleshooting

	Phenomenon	Cause	Corrective Action
1	Motor does not rotate.	(1) The phase sequence of the motor or encoder wiring is wrong. (2) The control mode selection, Pr. 800, setting is improper. (3) The servo on signal or start signal (STF, STR) is not input. (4) The command pulses are not input correctly. (FR-V5AP)  (5) The position command source selection, Pr. 419, setting is not correct. (6) When the position command source selection, Pr. 419, setting is 0, the position feed amount, Pr. 465 to Pr. 494, settings are not correct.	(1) Check the wiring. (Refer to page 55)  (2) Check the Pr. 800 setting. (Factory setting is speed control) (3) Check that the signals are input normally.  (4)-1 Check that the command pulses are input normally. (Check the cumulative command pulse value in Pr. 430.) (4)-2 Check the command pulse form and command pulse selection, Pr. 428, setting. (5) Check the position command source selection in Pr. 419. (6) Check the position feed amounts in Pr. 465 to Pr. 494.
2	Position shift occurs.	(1) The command pulses are not input correctly.  (2) The command is affected by noise or the encoder feedback is compounded with noise.	(1)-1 Check the command pulse form and command pulse selection, Pr. 428, setting. (1)-2 Check that the command pulses are input normally. (Check the cumulative command pulse value in Pr. 430.) (2)-1 Decrease the PWM carrier frequency in Pr. 72. (2)-2 Change the shielded cable earthing (grounding) place or raise the cable.
3	Motor or machine hunts.	(1) The position loop gain is high. (2) The speed loop gain is high.	(1) Decrease Pr. 422. (2)-1 Perform easy gain tuning. (2)-2 Decrease Pr. 820 and increase Pr. 821.
4	Machine operation is unstable.	(1) The acceleration/deceleration time setting has adverse effect.	(1) Decrease Pr. 7 and Pr. 8.

### Related parameter reference pages

- Pr. 800 "control system selection" (Refer to page 169.)
- Pr. 802 "pre-excitation selection" (Refer to page 82.)
- Pr. 820 "speed control P gain 1" (Refer to page 175.)
- Pr. 7 "acceleration time" (Refer to page 78.)
- Pr. 8 "deceleration time" (Refer to page 78.)
- Pr. 72 "PWM frequency selection" (Refer to page 112.)
- Pr. 821 "speed control integral time 1" (Refer to page 175.)



**2.7.12 Position control is not exercised normally**

**(1) Position control**

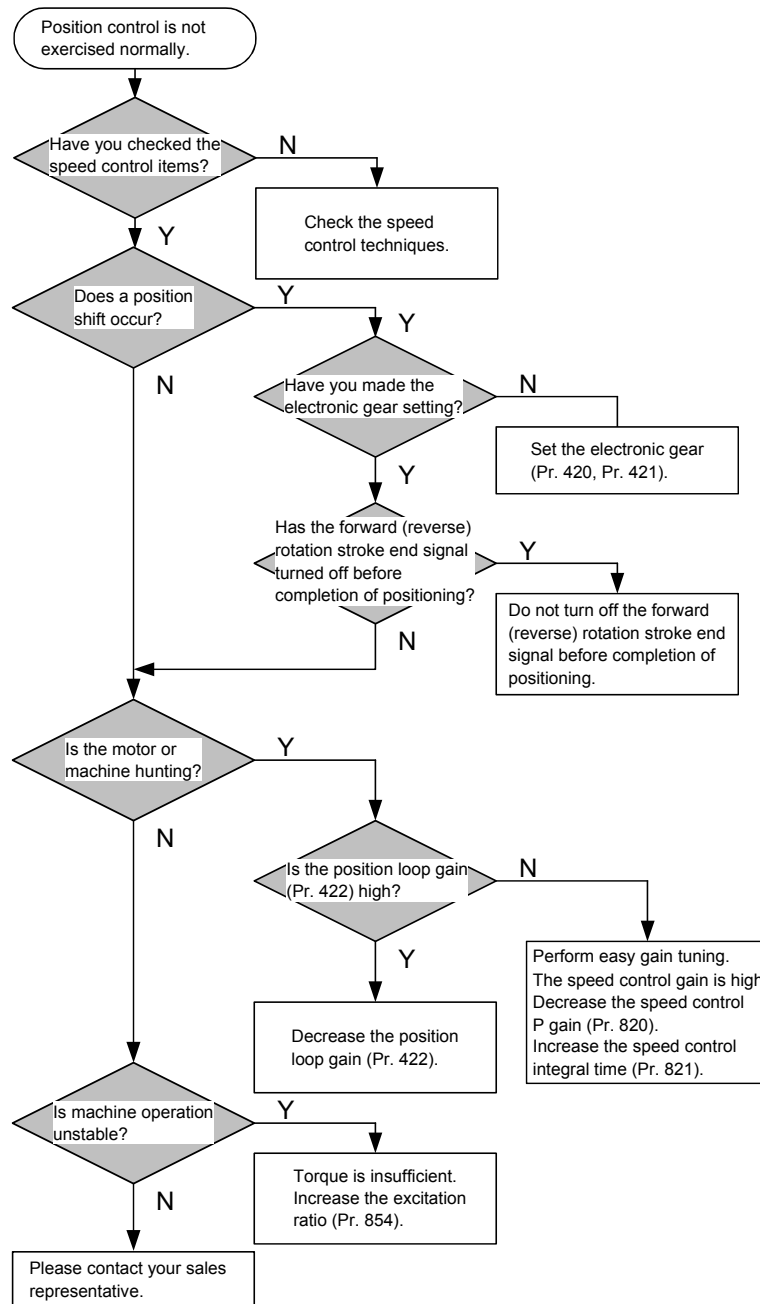

**REMARKS**

The speed command of position control relates to speed control. Refer to the Instruction Manual (basic) for details.

# 3

# PARAMETERS

---

This chapter explains the "parameters" for use of this product.

Always read the instructions and other information before using the equipment.

---

The following marks indicate availability of parameters under each control.

**speed** : Available under speed control

**torque** : Available under torque control

**position** : Available under position control

**position** : Available under position control by parameter settings

1

2

3

4

## Parameter list

### 3.1 Parameter list

The inverter is factory-set to display only the simple mode parameters.  
Set Pr. 160 "extended function selection" as required.

Parameter	Name	Factory Setting	Setting Range	Remarks
160	Extended function selection	0	0	Accessible to only the simple mode parameters.
			1	Accessible to all parameters.

#### CAUTION

- The blacked out parameters in the table below indicate simple mode parameters.
- The shaded parameters in the table allow its setting to be changed during operation even if "0" (factory setting) is set in Pr. 77 (parameter write disable selection).
- \*: Accessible when Pr. 77 = 801.

Function	Parameter No.	Name	Setting Range	Minimum Setting Increments	Factory Setting	Refer To	Customer Setting
Basic functions	0	Torque boost (manual)	0 to 30%	0.1%	4%/3%/2% (3.7K or less/ 5.5K, 7.5K/ 11K or more)	76	
	1	Maximum speed	0 to 3600r/min	1r/min	1500r/min	76	
	2	Minimum speed	0 to 3600r/min	1r/min	0r/min	76	
	3	Base frequency	10 to 200Hz	0.01Hz	60Hz	77	
	4	Multi-speed setting (high speed)	0 to 3600r/min	1r/min	1500r/min	77	
	5	Multi-speed setting (middle speed)	0 to 3600r/min	1r/min	750r/min	77	
	6	Multi-speed setting (low speed)	0 to 3600r/min	1r/min	150r/min	77	
	7	Acceleration time	0 to 3600s/0 to 360s	0.1s/0.01s	5s/15s (1.5K to 5.5K /7.5K to 55K)	78	
	8	Deceleration time	0 to 3600s/0 to 360s	0.1s/0.01s	5s/15s (1.5K to 5.5K /7.5K to 55K)	78	
Standard operation functions	9	Electronic thermal O/L relay	0 to 500A	0.01A	0A	80	
	10	DC injection brake operation speed	0 to 1500r/min, 9999	0.1r/min	15r/min	82	
	11	DC injection brake operation time	0 to 0.5s	0.1s	0.5s	82	
	12	DC injection brake voltage	0 to 30%	0.1%	4%/2% (7.5K or less/ 11K or more)	82	
	13	Starting speed	0 to 1500r/min	0.1r/min	15r/min	84	
	15	Jog speed setting	0 to 1500r/min	0.1r/min	150r/min	85	
Operation selection functions	16	Jog acceleration/deceleration time	0 to 3600s/0 to 360s	0.1s/0.01s	0.5s	85	
	17	MRS input selection	0, 2	1	0	86	
	19	Base frequency voltage	0 to 1000V, 8888, 9999	0.1V	9999	77	
	20	Acceleration/deceleration reference speed	1 to 3600r/min	1r/min	1500r/min	78	
	21	Acceleration/deceleration time increments	0, 1	1	0	78	
	22	Torque limit level	0 to 400%	0.1%	150%	87	
	24	Multi-speed setting (speed 4)	0 to 3600r/min, 9999	1r/min	9999	77	
	25	Multi-speed setting (speed 5)	0 to 3600r/min, 9999	1r/min	9999	77	
	26	Multi-speed setting (speed 6)	0 to 3600r/min, 9999	1r/min	9999	77	
	27	Multi-speed setting (speed 7)	0 to 3600r/min, 9999	1r/min	9999	77	
	28	Multi-speed input compensation	0, 1	1	0	88	
	29	Acceleration/deceleration pattern	0, 1, 2, 3, 4	1	0	89	
	30	Regenerative function selection	0, 1, 2	1	0	92	
31	Speed jump 1A	0 to 3600r/min, 9999	1r/min	9999	93		
32	Speed jump 1B	0 to 3600r/min, 9999	1r/min	9999	93		

Function	Parameter No.	Name	Setting Range	Minimum Setting Increments	Factory Setting	Refer To	Customer Setting
Operation selection functions	33	Speed jump 2A	0 to 3600r/min, 9999	1r/min	9999	93	
	34	Speed jump 2B	0 to 3600r/min, 9999	1r/min	9999	93	
	35	Speed jump 3A	0 to 3600r/min, 9999	1r/min	9999	93	
	36	Speed jump 3B	0 to 3600r/min, 9999	1r/min	9999	93	
Display function	37	Speed display	0, 1 to 9998	1	0	93	
Output terminal functions	41	Up-to-speed sensitivity	0 to 100%	0.1%	10%	95	
	42	Speed detection	0 to 3600r/min	1r/min	300r/min	95	
	43	Speed detection for reverse rotation	0 to 3600r/min, 9999	1r/min	9999	95	
Second functions	44	Second acceleration/deceleration time	0 to 3600s/0 to 360s	0.1s/0.01s	5s	78	
	45	Second deceleration time	0 to 3600s/0 to 360s, 9999	0.1s/0.01s	9999	78	
Output terminal function	50	Second speed detection	0 to 3600r/min	1r/min	750r/min	95	
Display functions	52	DU/PU main display data selection	0, 5 to 12, 17 to 20, 23, 24, 32 to 35, 38, 100	1	0	97	
	53	PU level display data selection	0 to 3, 5 to 12, 17, 18	1	1	97	
	54	DA1 terminal function selection	1 to 3, 5 to 12, 17, 18, 21, 32 to 34, 36	1	1	97	
	55	Speed monitoring reference	0 to 3600r/min	1r/min	1500r/min	100	
	56	Current monitoring reference	0 to 500A	0.01A	Inverter rated current	100	
Automatic restart	57	Restart coasting time	0, 0.1 to 5s, 9999	0.1s	9999	101	
	58	Restart cushion time	0 to 60s	0.1s	1.0s	101	
Additional function	59	Remote setting function selection	0, 1, 2, 3	1	0	103	
Operation selection functions	60	Intelligent mode selection	0, 7, 8	1	0	106	
	65	Retry selection	0 to 5	1	0	109	
	67	Number of retries at alarm occurrence	0 to 10, 101 to 110	1	0	109	
	68	Retry waiting time	0 to 10s	0.1s	1s	109	
	69	Retry count display erasure	0	1	0	109	
	70	Special regenerative brake duty	0 to 15%/0 to 30%	0.1%	0%	92	
	71	Applied motor	0, 3 to 8, 10, 13 to 18, 20, 23, 24, 30, 33, 34	1	30	111	
	72	PWM frequency selection	1 to 6	1	1	112	
	73	Speed setting signal	0, 4, 10, 14	1	0	113	
	75	Reset selection/disconnected PU detection/PU stop selection	0 to 3, 14 to 17	1	14	115	
	77	Parameter write disable selection	0, 1, 2	1	0	116	
78	Reverse rotation prevention selection	0, 1, 2	1	0	117		
79	Operation mode selection	0 to 4, 6 to 8	1	0	117		
Motor constants	80	Motor capacity	0.4 to 55kW	0.01kW	Inverter capacity	120	
	81	Number of motor poles	2, 4, 6	1	4	120	
	82	Motor excitation current (no load current) *	0 to , 9999		9999	123	
	83	Rated motor voltage	0 to 1000V	0.1V	200V (200V class) / 400V (400V class)	120	
	84	Rated motor frequency	10 to 200Hz	0.01Hz	60Hz	120	
	90	Motor constant R1 *	0 to , 9999		9999	123	
	91	Motor constant R2 *	0 to , 9999		9999	123	
	92	Motor constant L1 *	0 to , 9999		9999	123	
	93	Motor constant L2 *	0 to , 9999		9999	123	
	94	Motor constant X *	0 to , 9999		9999	123	
	95	Online auto tuning selection	0, 1, 2	1	0	126	
96	Auto tuning setting/status	0, 1, 101	1	0	120		
Third functions	110	Third acceleration/deceleration time	0 to 3600/0 to 360s	0.1s/0.01s	5s	78	
	111	Third deceleration time	0 to 3600/0 to 360s, 9999	0.1s/0.01s	9999	78	

## Parameter list

Function	Parameter No.	Name	Setting Range	Minimum Setting Increments	Factory Setting	Refer To	Customer Setting	
Output terminal function	116	Third speed detection	0 to 3600r/min	1r/min	1500r/min	95		
Communication functions	117	Communication station number	0 to 31	1	0	128		
	118	Communication speed	48, 96, 192	1	192	128		
	119	Stop bit length/data length	0, 1, 10, 11	1	1	128		
	120	Parity check presence/absence	0, 1, 2	1	2	128		
	121	Number of communication retries	0 to 10, 9999	1	1	128		
	122	Communication check time interval	0 to 999.8s, 9999	0.1s	0	128		
	123	Waiting time setting	0 to 150ms, 9999	1ms	9999	128		
PID control	124	CR, LF selection	0, 1, 2	1	1	128		
	128	PID action selection	10, 11, 30, 31	1	10	139		
	129	PID proportional band	0.1 to 1000%, 9999	0.1%	100%	139		
	130	PID integral time	0.1 to 3600s, 9999	0.1s	1s	139		
	131	Upper limit	0 to 100%, 9999	0.1%	9999	139		
	132	Lower limit	0 to 100%, 9999	0.1%	9999	139		
Backlash	133	PID action set point for PU operation	0 to 100%	0.01%	0%	139		
	134	PID differential time	0.01 to 10s, 9999	0.01s	9999	139		
	140	Backlash acceleration stopping speed	0 to 3600r/min	1r/min	30r/min	89		
	141	Backlash acceleration stopping time	0 to 360s	0.1s	0.5s	89		
Display functions	142	Backlash deceleration stopping speed	0 to 3600r/min	1r/min	30r/min	89		
	143	Backlash deceleration stopping time	0 to 360s	0.1s	0.5s	89		
	144	Speed setting switchover	0, 2, 4, 6, 8, 10	1	0	93		
Current detection	145	Parameter for the option (FR-PU04V)						
	150	Output current detection level	0 to 200%	0.1%	150%	146		
	151	Output current detection period	0 to 10s	0.1s	0	146		
	152	Zero current detection level	0 to 200.0%	0.1%	5.0%	147		
Sub functions	153	Zero current detection period	0 to 1s	0.01s	0.5s	147		
	156	Stall prevention operation selection	0 to 31, 100, 101	1	1	148		
Display functions	157	OL signal output timer	0 to 25s, 9999	0.1s	0	149		
	158	DA2 terminal function selection	1 to 3, 5 to 12, 17, 18, 21, 32 to 34, 36	1	1	97		
Automatic restart after instantaneous power failure	160	Extended function selection	0, 1	1	0	150		
	162	Automatic restart after instantaneous power failure selection	0, 1, 10	1	0	101		
	163	First cushion time for restart	0 to 20s	0.1s	0s	101		
	164	First cushion voltage for restart	0 to 100%	0.1%	0%	101		
Maintenance functions	165	Restart current limit level	0 to 200%	0.1%	150%	101		
	168	Maker setting parameters. Do not set.						
Terminal assignment functions	169	Maker setting parameters. Do not set.						
	171	Actual operation hour meter clear	0	1	0	150		
	180	DI1 terminal function selection	0 to 3, 5, 8 to 12, 14 to 16, 20, 22 to 28, 42 to 44, 9999	1	0	150		
	181	DI2 terminal function selection		1	1			
	182	DI3 terminal function selection		1	2			
	183	DI4 terminal function selection		1	3			
	187	STR terminal function selection		1	9999			
	190	DO1 terminal function selection	0 to 8, 10 to 16, 20, 25 to 27, 30 to 37, 39, 40 to 44, 96 to 99, 100 to 108, 110 to 116, 120, 125 to 127, 130 to 137, 139, 140 to 144, 196 to 199, 9999	1	0	152		
191	DO2 terminal function selection	1		1				
192	DO3 terminal function selection	1		2				
195	A,B,C terminal function selection	1		99				
Multi-speed operation	232	Multi-speed setting (speed 8)	0 to 3600r/min, 9999	1r/min	9999	77		
	233	Multi-speed setting (speed 9)	0 to 3600r/min, 9999	1r/min	9999	77		
	234	Multi-speed setting (speed 10)	0 to 3600r/min, 9999	1r/min	9999	77		
	235	Multi-speed setting (speed 11)	0 to 3600r/min, 9999	1r/min	9999	77		
	236	Multi-speed setting (speed 12)	0 to 3600r/min, 9999	1r/min	9999	77		

Function	Parameter No.	Name	Setting Range	Minimum Setting Increments	Factory Setting	Refer To	Customer Setting
Multi-speed operation	237	Multi-speed setting (speed 13)	0 to 3600r/min, 9999	1r/min	9999	77	
	238	Multi-speed setting (speed 14)	0 to 3600r/min, 9999	1r/min	9999	77	
	239	Multi-speed setting (speed 15)	0 to 3600r/min, 9999	1r/min	9999	77	
Sub functions	240	Soft-PWM setting	0, 1, 10, 11	1	10	112	
	244	Cooling fan operation selection	0, 1	1	0	154	
Stop selection function	250	Stop selection	0 to 100s, 9999	0.1s	9999	154	
Operation selection function	251	Output phase failure protection selection	0, 1	1	1	155	
Additional functions	252	Override bias	0 to 200%	0.1%	50%	156	
	253	Override gain	0 to 200%	0.1%	150%	156	
Power failure stop functions	261	Power failure stop selection	0, 1	1	0	156	
	262	Subtracted speed at deceleration start	0 to 600r/min	1r/min	90r/min	156	
	263	Subtraction starting speed	0 to 3600r/min, 9999	1r/min	1500r/min	156	
	264	Power-failure deceleration time 1	0 to 3600/0 to 360s	0.1s/0.01s	5s	156	
	265	Power-failure deceleration time 2	0 to 3600/0 to 360s, 9999	0.1s/0.01s	9999	156	
	266	Power-failure deceleration time switchover speed	0 to 3600r/min	1r/min	1500r/min	156	
Brake sequence	278	Brake opening speed	0 to 900r/min	1r/min	20r/min	106	
	279	Brake opening current	0 to 200%	0.1%	130%	106	
	280	Brake opening current detection time	0 to 2s	0.1s	0.3s	106	
	281	Brake operation time at start	0 to 5s	0.1s	0.3s	106	
	282	Brake operation speed	0 to 900r/min	1r/min	25r/min	106	
	283	Brake operation time at stop	0 to 5s	0.1s	0.3s	106	
	284	Deceleration detection function selection	0, 1	1	0	106	
Droop	285	Overspeed detection speed	0 to 900r/min, 9999	1r/min	9999	106	
	286	Droop gain	0 to 100.0%	0.01%	0%	158	
	287	Droop filter time constant	0.00 to 1.00s	0.01s	0.3s	158	
Additional function	288	Droop function activation selection	0, 1, 2	1	0	158	
Orientation	342	E <sup>2</sup> PROM write selection	0, 1	1	0	128	
	350	Stop position command selection	0, 1, 2, 3, 9999	1	9999	159	
	351	Orientation switchover speed	0 to 1000r/min	1r/min	200r/min	159	
	356	Internal stop position command	0 to 16383	1	0	159	
	357	In-position zone	0 to 8192	1	11	159	
	360	External position command selection	0, 1, 2 to 127	1	0	159	
	361	Position shift	0 to 16383	1	0	159	
Control system function	362	Orientation position loop gain	0.1 to 100	0.1	10	159	
	374	Overspeed detection level	0 to 4200r/min	1r/min	3450r/min	166	
S-pattern C	380	Acceleration S pattern 1	0 to 50%	1%	0%	89	
	381	Deceleration S pattern 1	0 to 50%	1%	0%	89	
	382	Acceleration S pattern 2	0 to 50%	1%	0%	89	
	383	Deceleration S pattern 2	0 to 50%	1%	0%	89	
Orientation	393	Orientation selection	1, 2, 10, 11, 12	1	0	159	
	396	Orientation speed gain (P term)	0 to 1000%	1	60%	159	
	397	Orientation speed integral time	0 to 20.0s	0.001	0.333	159	
	398	Orientation speed gain (D term)	0 to 100.0%	0.1	1	159	
	399	Orientation deceleration ratio	0 to 1000	1	20	159	
Additional function	408	Motor thermistor selection	0, 1	1	0	212	

## Parameter list

Function	Parameter No.	Name	Setting Range	Minimum Setting Increments	Factory Setting	Refer To	Customer Setting
Position control	419	Position command source selection	0, 1	1	0	57	
	420	Command pulse scaling factor numerator	0 to 32767	1	1	57	
	421	Command pulse scaling factor denominator	0 to 32767	1	1	57	
	422	Position loop gain	0 to 150s <sup>-1</sup>	1s <sup>-1</sup>	25s <sup>-1</sup>	57	
	423	Position feed forward gain	0 to 100%	1%	0%	57	
	424	Position command acceleration/ deceleration time constant	0 to 50s	0.001s	0s	57	
	425	Position feed forward command filter	0 to 5s	0.001s	0s	57	
Position control	426	In-position width	0 to 32767 pulses	1 pulse	100 pulses	57	
	427	Excessive level error	0 to 400K, 9999	1K	40K	57	
	430	Pulse monitor selection	0 to 5, 9999	1	9999	57	
Motor constants	450	Second applied motor	0, 10, 30, 9999	1	9999	111	
	451	Second motor control method selection	20, 9999	1	9999	169	
	452	Second electronic thermal O/L relay	0 to 500A, 9999	0.01A	9999	80	
	453	Second motor capacity	0.4 to 55kW	0.01kW	Inverter capacity	38	
	454	Number of second motor poles	2, 4, 6	1	4	38	
Position control	464	Digital position control sudden stop deceleration time	0 to 360.0s	0.1s	0	57	
	465	First position feed amount lower 4 digits	0 to 9999	1	0	59	
	466	First position feed amount upper 4 digits	0 to 9999	1	0	59	
	467	Second position feed amount lower 4 digits	0 to 9999	1	0	59	
	468	Second position feed amount upper 4 digits	0 to 9999	1	0	59	
	469	Third position feed amount lower 4 digits	0 to 9999	1	0	59	
	470	Third position feed amount upper 4 digits	0 to 9999	1	0	59	
	471	Fourth position feed amount lower 4 digits	0 to 9999	1	0	59	
	472	Fourth position feed amount upper 4 digits	0 to 9999	1	0	59	
	473	Fifth position feed amount lower 4 digits	0 to 9999	1	0	59	
	474	Fifth position feed amount upper 4 digits	0 to 9999	1	0	59	
	475	Sixth position feed amount lower 4 digits	0 to 9999	1	0	59	
	476	Sixth position feed amount upper 4 digits	0 to 9999	1	0	59	
	477	Seventh position feed amount lower 4 digits	0 to 9999	1	0	59	
	478	Seventh position feed amount upper 4 digits	0 to 9999	1	0	59	
	479	Eighth position feed amount lower 4 digits	0 to 9999	1	0	59	
	480	Eighth position feed amount upper 4 digits	0 to 9999	1	0	59	
	481	Ninth position feed amount lower 4 digits	0 to 9999	1	0	59	
	482	Ninth position feed amount upper 4 digits	0 to 9999	1	0	59	
	483	Tenth position feed amount lower 4 digits	0 to 9999	1	0	59	
	484	Tenth position feed amount upper 4 digits	0 to 9999	1	0	59	
	485	Eleventh position feed amount lower 4 digits	0 to 9999	1	0	59	
	486	Eleventh position feed amount upper 4 digits	0 to 9999	1	0	59	
	487	Twelfth position feed amount lower 4 digits	0 to 9999	1	0	59	
	488	Twelfth position feed amount upper 4 digits	0 to 9999	1	0	59	
	489	Thirteenth position feed amount lower 4 digits	0 to 9999	1	0	59	
	490	Thirteenth position feed amount upper 4 digits	0 to 9999	1	0	59	
	491	Fourteenth position feed amount lower 4 digits	0 to 9999	1	0	59	
	492	Fourteenth position feed amount upper 4 digits	0 to 9999	1	0	59	
	493	Fifteenth position feed amount lower 4 digits	0 to 9999	1	0	59	
494	Fifteenth position feed amount upper 4 digits	0 to 9999	1	0	59		

Function	Parameter No.	Name	Setting Range	Minimum Setting Increments	Factory Setting	Refer To	Customer Setting
Remote output	495	Remote output selection	0, 1	1	0	168	
	496	Remote output data 1	0 to 4095	1	0	168	
	497	Remote output data 2	0 to 4095	1	0	168	
Operation selection functions	505	Speed setting reference	1 to 3600r/min	1	1500r/min	93	
	800	Control system selection	0 to 5, 9, 20	1	0	169	
	801	Torque characteristic selection	0, 1	1	1	169	
	802	Pre-excitation selection	0, 1	1	0	82	
	803	Constant power range torque characteristic selection	0, 1	1	0	87	
	804	Torque command source selection	0 to 6	1	0	171	
	805	Torque command source (RAM)	600 to 1400%	1%	1000%	171	
	806	Torque command source (RAM, E <sup>2</sup> PROM)	600 to 1400%	1%	1000%	171	
	807	Speed limit selection	0, 1, 2	1	0	173	
	808	Forward rotation speed limit	0 to 3600r/min	1r/min	1500r/min	173	
	809	Reverse rotation speed limit	0 to 3600r/min, 9999	1r/min	9999	173	
Control system functions	810	Torque restriction input method selection	0, 1	1	0	87	
	811	Set resolution switchover	0, 1, 10, 11	1	0	87	
	812	Torque limit level (regeneration)	0 to 400%, 9999	0.1%	9999	87	
	813	Torque limit level (3 quadrant)	0 to 400%, 9999	0.1%	9999	87	
	814	Torque limit level (4 quadrant)	0 to 400%, 9999	0.1%	9999	87	
	815	Torque limit level 2	0 to 400%, 9999	0.1%	9999	87	
	816	Acceleration torque limit level	0 to 400%, 9999	0.1%	9999	87	
	817	Deceleration torque limit level	0 to 400%, 9999	0.1%	9999	87	
	818	Easy gain tuning response level setting	1 to 15	1	2	175	
	819	Easy gain tuning selection	0, 1, 2	1	0	175	
	820	Speed control P gain 1	0 to 1000%	1%	60%	175	
	821	Speed control integral time 1	0 to 20s	0.001s	0.333s	175	
	822	Speed setting filter 1	0 to 5s	0.001s	0s	175	
	823	Speed detection filter 1	0 to 0.1s	0.001s	0.001s	176	
	824	Torque control P gain 1	0 to 200%	1%	100%	176	
	825	Torque control integral time 1	0 to 500ms	0.1ms	5ms	176	
	826	Torque setting filter 1	0 to 5s	0.001s	0s	176	
	827	Torque detection filter 1	0 to 0.1s	0.001s	0s	177	
	828	Model speed control gain	0 to 1000%	1%	60%	49	
	830	Speed control P gain 2	0 to 1000%, 9999	1%	9999	175	
831	Speed control integral time 2	0 to 20s, 9999	0.001s	9999	175		
832	Speed setting filter 2	0 to 5s, 9999	0.001s	9999	175		
833	Speed detection filter 2	0 to 0.1s, 9999	0.001s	9999	176		
834	Torque control P gain 2	0 to 200%, 9999	1%	9999	176		
835	Torque control integral time 2	0 to 500ms, 9999	0.1ms	9999	176		
836	Torque setting filter 2	0 to 5s, 9999	0.001s	9999	176		
837	Torque detection filter 2	0 to 0.1s, 9999	0.001s	9999	177		
Torque biases	840	Torque bias selection	0 to 3, 9999	1	9999	177	
	841	Torque bias 1	600 to 1400%, 9999	1%	9999	177	
	842	Torque bias 2	600 to 1400%, 9999	1%	9999	177	
	843	Torque bias 3	600 to 1400%, 9999	1%	9999	177	
	844	Torque bias filter	0 to 5s, 9999	0.001s	9999	177	
	845	Torque bias operation time	0 to 5s, 9999	0.01s	9999	177	
	846	Torque bias balance compensation	0 to 10V, 9999	0.1V	9999	177	
	847	Fall-time torque bias terminal 3 bias	0 to 400%, 9999	1%	9999	177	
848	Fall-time torque bias terminal 3 gain	0 to 400%, 9999	1%	9999	177		



## Parameter list

Function	Parameter No.	Name	Setting Range	Minimum Setting Increments	Factory Setting	Refer To	Customer Setting
Additional functions	849	Analog input offset adjustment *	0 to 200%	0.1%	100%	193	
	851	Number of encoder pulses	0 to 4096	1	2048	180	
	852	Encoder rotation direction	0, 1	1	1	180	
	854	Excitation ratio	0 to 100%	1%	100%	181	
	859	Torque current *	0 to , 9999	1	9999	123	
	862	Notch filter frequency	0 to 31	1	0	181	
	863	Notch filter depth	0 to 3	1	0	181	
	864	Torque detection	0 to 400%	0.1%	150%	182	
Display functions	865	Low speed detection	0 to 3600r/min	1r/min	45r/min	182	
	866	Torque monitoring reference	0 to 400%	0.1%	150%	100	
Terminal assignment function	867	DA1 output filter	0 to 5s	0.001s	0.05s	183	
	868	Terminal 1 function assignment	0, 1, 2, 5, 9999	1	0	183	
Protective functions	870	Speed deviation level	0 to 1500r/min, 9999	1r/min	9999	184	
	871	Speed deviation time	0 to 100s	0.1s	12s	184	
	873	Speed limit	0 to 3600r/min	1r/min	600r/min	185	
	874	OLT level setting	0 to 200%	0.1%	150%	185	
Operation selection functions	875	Fault definition	0, 1	1	0	186	
	876	Thermal relay protector input	0, 1	1	1	80	
Control system functions	877	Speed feed forward control/model adaptive speed control selection	0, 1, 2	1	0	49	
	878	Speed feed forward filter	0 to 1s	0.01s	0s	49	
	879	Speed feed forward torque limit	0 to 400%	0.1%	150%	49	
	880	Load inertia ratio	0, 1 to 200 times	0.1	7	49	
	881	Speed feed forward gain	0 to 1000%	1%	0%	49	
Maintenance functions	890	Maintenance output setting time	0 to 9998, 9999	10hr	9999	187	
	891	Maintenance output timer	0 to 9998	10hr	0	187	
	892	Maintenance output signal clear	0	1	0	187	
Calibration functions	900	DA1 terminal calibration				188	
	901	DA2 terminal calibration				188	
	902	Speed setting terminal 2 bias	0 to 10V, 0 to 3600r/min	0.1r/min	0V, 0r/min	190	
	903	Speed setting terminal 2 gain	0 to 10V, 0 to 3600r/min	1r/min	10V, 1500r/min	190	
	904	Torque command terminal 3 bias	0 to 10V, 0 to 400%	0.1%	0V, 0%	190	
	905	Torque command terminal 3 gain	0 to 10V, 0 to 400%	0.1%	10V, 150%	190	
	917	Terminal 1 terminal bias (speed)	0 to 10V, 0 to 3600r/min	0.1r/min	0V, 0r/min	190	
	918	Terminal 1 terminal gain (speed)	0 to 10V, 0 to 3600r/min	1r/min	10V, 1500r/min	190	
	919	Terminal 1 terminal bias (torque/magnetic flux)	0 to 10V, 0 to 400%	0.1%	0V, 0%	190	
Additional functions	920	Terminal 1 terminal gain (torque/magnetic flux)	0 to 10V, 0 to 400%	0.1%	10V, 150%	190	
	990	PU buzzer control	0, 1	1	1	193	
	991	Parameter for the option (FR-PU04V)					

### 3.2 At-a-glance guide to functions

○...Usable function, ×..... Unusable function

Category	Function	Control		Vector with encoder		
		Pr. number	Terminal	Speed	Torque	Position
				SF-V5RU "Motor with encoder (standard, constant torque)" *: This function can be usable under position control by parameter setting.		
Control	Speed limit	Pr. 807 to Pr. 809, Pr. 873, Pr. 902, Pr. 903, Pr. 917, Pr. 918	Terminal 2 (1), multi-speed	×	○	×
	Torque limit	Pr. 22, Pr. 803, Pr. 810 to Pr. 817, Pr. 904, Pr. 905, Pr. 919, Pr. 920	Terminal 3 (1)	○	×	○
	Offline auto tuning	Pr. 9, Pr. 71, Pr. 80 to Pr. 84, Pr. 90 to Pr. 94, Pr. 96, Pr. 859		○	○	×
	Online auto tuning (start time) Pr. 95 = 1	Pr. 95		○	○	×
	Online auto tuning (adaptive magnetic flux observer) Pr. 95 = 2	Pr. 95		○	○	○
	Easy gain tuning	Pr. 818, Pr. 819		○	×	○
	Gain adjustment	Pr. 820 to Pr. 827, Pr. 830 to Pr. 837		○	○	○
	Machine analyzer (notch filter)	Pr. 862, Pr. 863		○	×	○
	0 speed control	Pr. 802		○	×	○
	Servo lock	Pr. 802		○	×	○
	Variable excitation	Pr. 854		○	○	○
	Speed feed-forward, model adaptive speed control	Pr. 877 to Pr. 881, Pr. 820, Pr. 821, Pr. 828		○	×	○
	P/PI switchover	Pr. 180 to Pr. 183, Pr. 187	X44 signal	○	○	○
	Speed feedback filter	Pr. 823, Pr. 833		○	○	○
Basic functions	Extended function display	Pr. 160		○	○	○
	Maximum speed	Pr. 1		○	○	○
	Minimum speed	Pr. 2		○	○	×
	Acceleration time	Pr. 7, Pr. 8, Pr. 20, Pr. 21, Pr. 44, Pr. 45, Pr. 110, Pr. 111		○	○	×*
	Acceleration/deceleration pattern	Pr. 29, Pr. 140 to Pr. 143, Pr. 380 to Pr. 383		○	○	×
	Jog operation mode	Pr. 15, Pr. 16		○	○	×
	PWM frequency selection	Pr. 72, Pr. 240		○	○	○
	Operation mode (PU/external/combined)	Pr. 79		○	○	×
	Switchover mode	Pr. 79		○	○	×
	PU operation interlock mode	Pr. 79, Pr. 180 to Pr. 183, Pr. 187	X12	○	○	○
	Operation mode external signal switchover mode	Pr. 79, Pr. 180 to Pr. 183, Pr. 187	X16	○	○	○
	Start command (2-wire, 3-wire)	Pr. 180 to Pr. 183, Pr. 187	STOP	○	○	○
Parameter write disable selection	Pr. 77		○	○	○	
Application functions	Starting speed	Pr. 13		○	○	×
	DC injection brake	Pr. 10, Pr. 11, Pr. 12		○	○	×
	Second, third functions	Pr. 180 to Pr. 183, Pr. 187	RT, X9	○	○	○
	Multi-speed setting	Pr. 4 to Pr. 6, Pr. 24 to Pr. 27, Pr. 28, Pr. 232 to Pr. 239		○	○	×*
	Remote setting	Pr. 59		○	○	×
	Speed jump	Pr. 31 to Pr. 36		○	○	×
	PID control	Pr. 128 to Pr. 134, Pr. 180 to Pr. 183, Pr. 187	X14	○	×	×
	Stop selection	Pr. 250		○	○	×
	Power failure stop	Pr. 261 to Pr. 266		○	○	×
	PU stop	Pr. 75		○	○	○
	Reset selection	Pr. 75		○	○	○
	Forward/reverse rotation prevention	Pr. 78		○	○	○
	Automatic restart after instantaneous power failure	Pr. 57, Pr. 58		○	○	×
	Cooling fan on/off control	Pr. 244		○	○	○
	Retry function	Pr. 65, Pr. 67 to Pr. 69		○	○	×
Inverter RS485 communication	Pr. 117 to Pr. 124		○	○	○	
Droop control	Pr. 286 to Pr. 288		○	×	×	

# At-a-glance guide to functions

Category	Function	Pr. number	Terminal	Vector with encoder		
				Speed	Torque	Position
				SF-V5RU "Motor with encoder (standard, constant torque)" *: This function can be usable under position control by parameter setting.		
Application functions	Brake sequence	Pr. 60, Pr. 278 to Pr. 285		○	×	×
	Torque bias	Pr. 180 to Pr. 183, Pr. 187, Pr. 840 to Pr. 848, Pr. 904, Pr. 905	X42, X43	○	×	×
	Regenerative function selection	Pr. 30, Pr. 70		○	○	○
	Soft-PWM	Pr. 240		○	○	○
	Torque characteristic selection	Pr. 801		○	○	○
	Encoder rotation direction	Pr. 852		○	○	○
	Number of encoder pulses	Pr. 851		○	○	○
	Conditional position control by contact input	Pr. 465 to Pr. 494		×	×	○
	Direct display and direct setting of motor constants	Pr. 71, Pr. 82, Pr. 90 to Pr. 94, Pr. 859		○	○	○
	Speed setting/display unit switchover	Pr. 37, Pr. 144, Pr. 81, Pr. 454, Pr. 505, Pr. 811		○	○	○
	Electronic gear	Pr. 420, Pr. 421, Pr. 505, Pr. 811		×	×	○
Input functions	Multi-function input terminal assignment	Pr. 180 to Pr. 183, Pr. 187		○	○	○
	Analog input assignment/calibration	Pr. 868 / Pr. 902 to Pr. 920	Terminals 1, 2, 3	○	○	○
	Analog command filter time constant	Pr. 822, Pr. 826, Pr. 832, Pr. 836		○	○	○
	Override, polarity reversible	Pr. 73, Pr. 252, Pr. 253		○	○	×
	Output stop	Pr. 17, Pr. 180 to Pr. 183, Pr. 187	MRS	○	○	○
Output functions	Multi-function output terminal assignment	Pr. 190 to Pr. 192, Pr. 195		○	○	○
	Speed limit output	Pr. 190 to Pr. 192, Pr. 195	SL	×	○	×
	Inverter running signal	Pr. 13, Pr. 190 to Pr. 192, Pr. 195	RUN	○	○	○
	Up-to-speed signal	Pr. 41, Pr. 190 to Pr. 192, Pr. 195	SU	○	×	×
	Overload alarm signal	Pr. 190 to Pr. 192, Pr. 195	OL			
	Speed detection signal	Pr. 42, Pr. 43, Pr. 50, Pr. 116, Pr. 190 to Pr. 192, Pr. 195	FU, FU2, FU3 FB, FB2, FB3	○	×	×
	Regenerative brake prealarm signal	Pr. 190 to Pr. 192, Pr. 195	RBP	○	○	○
	Electronic thermal relay function prealarm signal	Pr. 190 to Pr. 192, Pr. 195	THP	○	○	○
	PU operation mode signal	Pr. 190 to Pr. 192, Pr. 195	PU	○	○	○
	Operation ready signal	Pr. 190 to Pr. 192, Pr. 195	RY	○	○	○
	Output current detection signal, zero current detection signal	Pr. 150, Pr. 151, Pr. 152, Pr. 153, Pr. 190 to Pr. 192, Pr. 195	Y12, Y13	○	○	○
	Fan fault output signal	Pr. 190 to Pr. 192, Pr. 195	FAN	○	○	○
	Fin overheat prealarm signal	Pr. 190 to Pr. 192, Pr. 195	FIN	○	○	○
	Forward, reverse rotation output signal	Pr. 190 to Pr. 192, Pr. 195	Y30, Y31	○	○	○
	Regenerative status output signal	Pr. 190 to Pr. 192, Pr. 195	Y32	○	○	○
	Operation ready 2 signal	Pr. 190 to Pr. 192, Pr. 195	RY2	○	○	○
	Low speed detection signal	Pr. 190 to Pr. 192, Pr. 195, Pr. 865	LS	○	○	○
	Torque detection signal	Pr. 190 to Pr. 192, Pr. 195, Pr. 864	TU	○	○	○
	Maintenance output	Pr. 190 to Pr. 192, Pr. 195, Pr. 890 to Pr. 892	MT	○	○	○
	Remote output	Pr. 190 to Pr. 192, Pr. 195, Pr. 495 to Pr. 497	REM	○	○	○
	Instantaneous power failure (undervoltage) signal	Pr. 190 to Pr. 192, Pr. 195	IPF	○	○	○
Monitor functions	Fault definition	Pr. 190 to Pr. 192, Pr. 195, Pr. 875	ER	○	○	×
	Minor fault output signal	Pr. 190 to Pr. 192, Pr. 195	LF	○	○	○
	Alarm output signal	Pr. 190 to Pr. 192, Pr. 195	ABC	○	○	○
	DU/PU display data selection	Pr. 52, Pr. 53		○	○	○
	DA1, DA2 output/calibration	Pr. 54 to Pr. 56, Pr. 866, Pr. 158, Pr. 900, Pr. 901	DA1, DA2	○	○	○
	DA1 output filter	Pr. 867	DA1	○	○	○
	Running speed monitor	Pr. 52 to Pr. 55, Pr. 158		○	○	○
	Output current monitor/output current peak value monitor	Pr. 52 to Pr. 54, Pr. 56, Pr. 158		○	○	○
	Output voltage monitor	Pr. 52 to Pr. 54, Pr. 158		○	○	○
	Preset speed monitor	Pr. 52 to Pr. 55, Pr. 158		○	○	○
	Output frequency monitor	Pr. 52 to Pr. 55, Pr. 158		○	○	○
Motor torque monitor	Pr. 52 to Pr. 54, Pr. 158, Pr. 866		○	○	○	
Converter output voltage monitor, converter output voltage peak value monitor	Pr. 52 to Pr. 54, Pr. 158		○	○	○	

Category	Function	Pr. number	Terminal	Control		
				Vector with encoder		
				Speed	Torque	Position
				SF-V5RU "Motor with encoder (standard, constant torque)" *: This function can be usable under position control by parameter setting.		
Monitor functions	Input terminal monitor, output terminal monitor	—		○	○	○
	Load meter monitor	Pr. 52 to Pr. 54, Pr. 158, Pr. 866		○	○	○
	Motor excitation current monitor	Pr. 52 to Pr. 54, Pr. 158, Pr. 56		○	○	○
	Cumulative energization time monitor	Pr. 52		○	○	○
	Actual operation time monitor	Pr. 52, Pr. 171		○	○	○
	Motor load factor	Pr. 52		○	○	○
	Orientation status	Pr. 52		○	×	×
	Option fitting status monitor	—		○	○	○
	Terminal assignment status monitor	—		○	○	○
	Motor output monitor	Pr. 52		○	○	○
	Feedback pulse monitor	Pr. 52		○	○	○
	Torque command/torque current command	Pr. 52, Pr. 54, Pr. 158, Pr. 866		○	○	○
Protective functions	Overcurrent protection	—		○	○	○
	Overvoltage protection	—		○	○	○
	Electronic thermal O/L relay	Pr. 9		○	○	○
	Fin overheat	—		○	○	○
	Brake transistor alarm	Pr. 30, Pr. 70		○	○	○
	Earth (Ground) fault overcurrent protection	—		○	○	○
	External thermal relay <OHT>	Pr. 876	OH	○	○	○
	Motor overload (OLT)	Pr. 865, Pr. 874		○	○	○
	Option alarm	—		○	○	○
	Parameter error	—		○	○	○
	Disconnected PU detection	Pr. 75		○	○	○
	Output phase failure protection	Pr. 251		○	○	○
	CPU error	—		○	○	○
	12/24VDC power supply short circuit protection	—		○	○	○
	Control panel power supply short circuit protection	—		○	○	○
	Overspeed occurrence	Pr. 374		○	○	○
	Speed deviation large	Pr. 870, Pr. 871		○	○	○
	Encoder no-signal	—		○	○	○
	Encoder A no-signal	—		○	×	×
Position error large	Pr. 427		×	×	○	
Output short circuit protection	—		○	○	○	
Encoder phase error (E. EP)	—		○	○	○	
PU	PU language changing	Pr. 145		○	○	○
	PU buzzer control	Pr. 990		○	○	○
	PU contrast adjustment	Pr. 991		○	○	○
Options	12-bit digital input "A5AX"	Pr. 300 to Pr. 305, Pr. 329		○	○	×
	Digital setting of torque command "A5AX"	Pr. 447, Pr. 448, Pr. 804		×	○	×
	Machine end orientation "V5AM"	Pr. 350 to Pr. 369, Pr. 390 to Pr. 396		○	×	×
	Pulse position control "V5AP"	Pr. 419 to Pr. 431		×	×	○
	Encoder output "V5AY"	Pr. 410 to Pr. 413		○	○	○
	Thermistor secondary resistance compensation "V5AX"	Pr. 407, Pr. 408, Pr. 925		○	○	○
	Extension analog input "V5AX"	Pr. 406		○	○	○
	Extension contact input "V5AX"	Pr. 400 to Pr. 405		○	○	○
	Digital output "A5AY, V5AY"	Pr. 313 to Pr. 319 / Pr. 410 to Pr. 413		○	○	○
	Extension analog output "A5AY"	Pr. 306 to Pr. 312		○	○	○
	Relay output "A5AR"	Pr. 320 to Pr. 322, Pr. 330		○	○	○
	Pulse train input "A5AP"	Pr. 384 to Pr. 386		○	○	×
	SSCNET "V5NS"	Pr. 79, Pr. 117, Pr. 338 to Pr. 342, Pr. 499		○	×	○
	Ethernet "V5NE"	Pr. 434 to Pr. 438		○	○	○
	RS485 communication "A5NR"	Pr. 331 to Pr. 342		○	○	○
	CC-Link "A5NC"	Pr. 338 to Pr. 342		○	○	○
	Profibus DP "A5NPA"	Pr. 338 to Pr. 342		○	○	○
	DeviceNet "A5ND"	Pr. 338 to Pr. 342, Pr. 345 to Pr. 348		○	○	○
16-bit digital input "V5AH"	Pr. 300 to Pr. 305, Pr. 329		○	○	×	
Trace (plug-in option)	Pr. 520 to Pr. 536		○	○	○	

### 3.3 Basic functions (Pr. 0 to Pr. 9)

#### 3.3.1 Torque boost (Pr. 0)

Use this parameter for V/F control only.

- Motor torque in the low speed region can be adjusted according to the load to increase the starting motor torque.

Parameter	Name	Factory Setting	Setting Range	Remarks
0	Torque boost (manual)	4%/3%/2% (3.7K or less/5.5K, 7.5K/11K or more)	0 to 30%	Extended mode

#### <Setting>

- Increase the setting value when the distance between the inverter and motor is long or when the motor torque in the low speed range is insufficient (when the stall prevention protective function is activated), etc.
- Assuming that the base frequency voltage is 100%, set the 0Hz voltage in %.

#### CAUTION

If the setting is too large, the motor may result in overheat or overcurrent trip. The guideline for maximum value is about 10%.

#### 3.3.2 Maximum and minimum speed settings

(Pr. 1 speed torque position, Pr. 2 speed torque)

You can limit the maximum (minimum) speed.

- Speed control  
The maximum setting is placed on the running speed.  
The minimum setting is placed on the preset speed.
- Torque control  
The maximum and minimum settings are made on the speed limit commands. (Limit is not placed on the running speed.)
- Position control  
The maximum setting is valid for the speed command obtained from the droop pulses. The minimum setting is invalid.

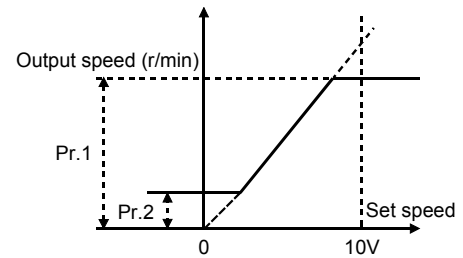

Parameter	Name	Factory Setting	Setting Range	Remarks
1	Maximum speed	1500r/min	0 to 3600r/min	Simple mode
2	Minimum speed	0r/min	0 to 3600r/min	Simple mode

#### <Setting>

##### ● Speed control

- When the upper limit of the output speed is set in Pr. 1, the output speed is clamped at the maximum speed even if the speed command entered is higher than the speed set in Pr.1. (This also applies to the minimum speed setting.)

## ⚠ CAUTION

⚠ When the Pr. 2 setting is higher than Pr. 13 "starting speed" value, note that the motor will run at the preset speed by merely turning the start signal on, even if the command speed has not been entered.

#### Related parameters

- Starting speed setting ⇒ Pr. 13 "starting speed" (Refer to page 84.)
- Speed limit command selection for torque control ⇒ Pr. 807 "speed limit selection" (Refer to page 173.)
- External (example: terminal 2-5 connection) speed setting potentiometer adjustment ⇒ Pr. 902 "speed setting terminal 2 bias" (Refer to page 190.),  
Pr. 903 "speed setting terminal 2 gain" (Refer to page 190.)

### 3.3.3 Base frequency, base frequency voltage (Pr. 3, Pr. 19)

Use this parameter for V/F control only.  
This parameter matches the inverter outputs (voltage, frequency) to the motor rating.

Parameter	Name	Factory Setting	Setting Range	Remarks
3	Base frequency	60Hz	10 to 200Hz	Extended mode
19	Base frequency voltage	9999	0 to 1000V, 8888, 9999	Extended mode 8888: 95% of power supply voltage 9999: Same as power supply voltage

#### <Setting>

- Use Pr. 3 to set the base frequency (rated motor frequency).
- If only "50Hz" is given on the motor rating plate as the frequency, always set the "base frequency" to "50Hz". If it remains at "60Hz", the voltage may become too low and torque shortage occurs, resulting in an overload trip.
- Use Pr. 19 to set the base voltage (e.g. rated motor voltage).  
The motor whose rated voltage is lower than the power supply voltage of the inverter can be used optimally. This function is useful when a motor rated at 200V is used with a 230V power supply.
- Set Pr. 19 "base frequency voltage" according to the motor as shown below.  
SF-V5RU-3.7kW or less . . . . . "170V"  
SF-V5RU-5.5kW or more . . . . . "160V"  
SF-V5RUH-3.7kW or less . . . . . "340V"  
SF-V5RUH-5.5kW or more. . . . . "320V"  
SF-VR. . . . . "160V"  
SF-VRH . . . . . "320V"  
Set "50Hz" in Pr. 3 "base frequency".

#### REMARKS

If vector control is disabled due to an encoder fault, setting "20" in Pr. 800 "control system selection" enables operation under V/F control. (Refer to page 169.)

#### Related parameters

Motor setting ⇒ Pr. 71 "applied motor", Pr. 450 "second applied motor" (Refer to page 111.)

### 3.3.4 Multi-speed operation

(Pr. 4 to Pr. 6, Pr. 24 to Pr. 27, Pr. 232 to Pr. 239 speed torque position)

Can be used to change between the predetermined running speeds by switching from one terminal to another.

- Any speed can be selected by merely turning on-off the contact signals (RH, RM, RL, REX signals).
- Using these parameters with Pr. 1 "maximum speed" and Pr. 2 "minimum speed" allows the setting of up to 17 speeds.

#### POINT

- Valid in the external operation mode or in the combined operation mode that is made available by setting "3 or 4" in Pr. 79.
- Valid when "0" is set in Pr. 59.

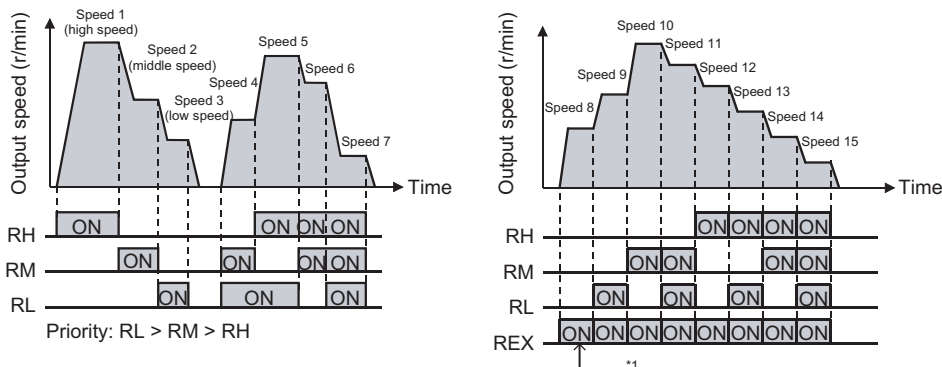

\*1 If "9999" is set in Pr. 232 "multi-speed setting (speed 8)", the output speed is 0r/min when RH, RM and RL are turned off and REX is turned on.

## Basic functions (Pr. 0 to Pr. 9)

Parameter	Name	Factory Setting	Setting Range	Remarks
4	Multi-speed setting (high speed)	1500r/min	0 to 3600r/min	Simple mode
5	Multi-speed setting (middle speed)	750r/min	0 to 3600r/min	Simple mode
6	Multi-speed setting (low speed)	150r/min	0 to 3600r/min	Simple mode
24 to 27	Multi-speed setting (speeds 4 to 7)	9999	0 to 3600r/min, 9999	"9999" No setting
232 to 239	Multi-speed setting (speeds 8 to 15)	9999	0 to 3600r/min, 9999	"9999" No setting

### <Setting>

- Set the running speeds in the corresponding parameters.  
Each speed can be set as desired in the range 0 to 3600r/min during inverter operation.  
With any multi-speed setting parameter being read, press / to change the setting.  
In this case, press to store the preset speed. (This is also enabled in the external mode.)  
Pressing reflects the preset speed.

### REMARKS

- Press when the FR-PU04V (option) is used.
- Use Pr. 180 to Pr. 183 and Pr. 187 to assign the terminals used for signals RH, RM, RL, and REX. (\*)  
\*Changing the terminal assignment using Pr. 180 to Pr. 183, Pr. 187 (input terminal function selection) may affect the other functions. Please make setting after confirming the function of each terminal.
- The priorities of the external terminals for speed commands are as follows.  
Jog > pulse train input (option FR-A5AP) > digital setting (option FR-A5AX) > multi-speed operation > PID > terminal 2

### CAUTION

- The multi-speed settings override the main speed (across terminals 2-5).
- The multi-speeds can also be set in the PU or external operation mode.
- For 3-speed setting, if two or more speeds are simultaneously selected, priority is given to the preset speed of the lower signal. (RL > RM > RH)
- Pr. 24 to Pr. 27 and Pr. 232 to Pr. 239 settings have no priority between them.
- The settings can also be changed during operation.
- When the jog signal is used with multi-speed signals, the jog signal has priority.

### Related parameters

- Maximum, minimum speed setting⇒ Pr. 1 "maximum speed", Pr. 2 "minimum speed" (Refer to page 76.)
- Signal RH, RM, RL, REX terminal assignment⇒ Pr. 180 to Pr. 183, Pr. 187 (input terminal function selection) (Refer to page 150.)
- External operation mode setting⇒ Pr. 79 "operation mode selection" (Refer to page 117.)
- Extended mode/simple mode setting⇒ Pr. 160 "extended function selection" (Refer to page 150.)

### 3.3.5 Acceleration and deceleration time

(Pr. 7, Pr. 8, Pr. 20, Pr. 21, Pr. 44, Pr. 45, Pr. 110, Pr. 111 )

Set the acceleration/deceleration time of the motor during speed control and position control by parameter setting.

Set a larger value for a slower speed increase/decrease or a smaller value for a faster speed increase/decrease.

Under torque control, the speed limit value varies with the acceleration/deceleration time.

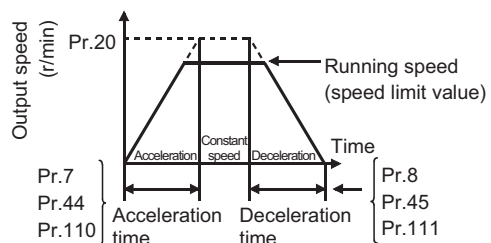

Parameter	Name	Factory Setting	Setting Range	Remarks	
7	Acceleration time	5s/15s (5.5K or less/7.5K or more)	0 to 3600s	Simple mode	
			0 to 360s		
8	Deceleration time	5s/15s (5.5K or less/7.5K or more)	0 to 3600s	Simple mode	
			0 to 360s		
20	Acceleration/ deceleration reference speed	1500r/min	1 to 3600 r/min	Extended mode	
21	Acceleration/ deceleration time increments	0	0, 1	0: 0 to 3600s 1: 0 to 360s	Extended mode
44	Second acceleration/ deceleration time	5s	0 to 3600s	Pr. 21 = 0	Extended mode
			0 to 360s	Pr. 21 = 1	
45	Second deceleration time	9999	0 to 3600s	Pr. 21 = 0	Extended mode
			0 to 360s	Pr. 21 = 1	
			9999	Acceleration time = deceleration time	
110	Third acceleration/ deceleration time	5s	0 to 3600s	Pr. 21 = 0	Extended mode
			0 to 360s	Pr. 21 = 1	
111	Third deceleration time	9999	0 to 3600s	Pr. 21 = 0	Extended mode
			0 to 360s	Pr. 21 = 1	
			9999	Acceleration time = deceleration time	

<Setting>

- Use Pr. 21 to set the acceleration/deceleration time and minimum setting range.  
Value "0" (factory setting) 0 to 3600s (minimum setting increments: 0.1s)  
Value "1" 0 to 360s (minimum setting increments: 0.01s)  
Changing the Pr. 21 value changes the setting of Pr. 7, Pr. 8, Pr. 44, Pr. 45, Pr. 110 and Pr. 111.

**CAUTION**

Changing the Pr. 21 setting changes the acceleration/deceleration time setting (Pr. 7, Pr. 8, Pr. 16, Pr. 44, Pr. 45, Pr. 110, Pr. 111)

<Example>

When Pr.21="0" and the setting of Pr.7="5.0"s, and if the setting of Pr.21 is changed to "1", the setting value of Pr.7 will change to "0.5"s.

- Use Pr. 7, Pr. 44 and Pr. 110 to set the acceleration time taken to reach the speed set in Pr. 20 from 0r/min.
- Use Pr. 8, Pr. 45 and Pr. 111 to set the deceleration time taken to reach 0r/min from the speed set in Pr. 20.
- Use Pr. 180 to Pr. 183 and Pr. 187 to assign the terminals used to input the RT and X9 signals.

**CAUTION**

- Pr. 44 and Pr. 45 are valid when the RT signal is on.  
When the RT signal is on, the other second functions (Pr. 450 to Pr. 454, Pr. 815, Pr. 830 to Pr. 837) are also valid.
- Pr. 110 and Pr. 111 are valid when the X9 signal is on.  
When the X9 signal is on, Pr. 820 to Pr. 827 are also valid.
- When both RT and X9 are on, Pr. 110 and Pr. 111 are valid.
- Switching the RT and X9 signals during operation does not change the acceleration/deceleration time immediately when position control is exercised with the conditional position control function (Pr. 419 = "0") by the contact input.

**REMARKS**

- Changing the Pr. 20 "acceleration/deceleration reference speed" setting does not adjust the speed gain setting signal. To adjust the gain, adjust the calibration function (Pr. 903).
- When the setting of Pr. 7, Pr. 8, Pr. 44, Pr. 45, Pr. 110 or Pr. 111 is 0.03 or less under V/F control, the acceleration/deceleration time is 0.04s.
- However short the acceleration/deceleration time setting is, the actual motor acceleration/deceleration time cannot be made shorter than the shortest acceleration/deceleration time that is determined by the mechanical system J (moment of inertia) and the motor torque.

**Related parameters**

- Jog acceleration/deceleration time ⇒ Pr. 16 "jog acceleration/deceleration time" (Refer to page 85.)
- RT signal, X9 signal setting ⇒ Pr. 180 to Pr. 183, Pr. 187 (input terminal function selection) (Refer to page 150.)



**3.3.6 Motor overheat protection (Pr. 9, Pr. 452, Pr. 876)** speed torque position

When an external thermal relay is not used, protect the motor from overheat by integration processing of the inverter output current. This feature provides the optimum protective characteristics, including reduced motor cooling capability, at low speed.

Parameter	Name	Factory Setting	Setting Range	Remarks
9	Electronic thermal O/L relay	0	0 to 500A	Extended mode
452	Second electronic thermal O/L relay	9999	0 to 500A, 9999	Extended mode 9999: Without second electronic thermal relay function
876	Thermal relay protector input	1	0, 1	Extended mode

**<Setting>**

- When not using an external thermal relay, set the rated current value [A] of the motor in Pr. 9 (Pr. 452) to make the electronic thermal relay function valid.  
(Normally set the rated current value at 50Hz. When the rated current value of 50Hz is not indicated on the name plate, set the value obtained from multiplying the rated current value of 60Hz by 1.1.)
- Setting "0" in Pr. 9 (Pr. 452) deactivates the electronic thermal relay function (motor protective function). (The inverter's output transistor protective function is activated.)  
When using the dedicated motor, set "0" since the thermal relay protector is onboard (outside).
- When using a Mitsubishi constant-torque motor, first set "10" in Pr.71 "applied motor". (This provides a 100% continuous torque characteristic in the low-speed region.) Then, set the rated current of the motor in Pr. 9 "electronic thermal O/L relay".
- The electronic thermal relay function of the second motor (Pr. 452 "second electronic thermal O/L relay" is made valid by:  
Turning on the RT signal; and  
Setting other than 9999 in Pr. 450.  
(The value set in Pr. 9 is valid when Pr. 452 = 9999.)

**● Selection for whether to use an external thermal relay or not (Pr. 876 "thermal relay protector input")**

Pr. 876 Setting	Motor with encoder (e.g. SF-JR)
0	When thermal relay etc. is not used (thermal relay protector input invalid)
1 (factory setting)	When thermal relay etc. is used (thermal relay protector input valid)

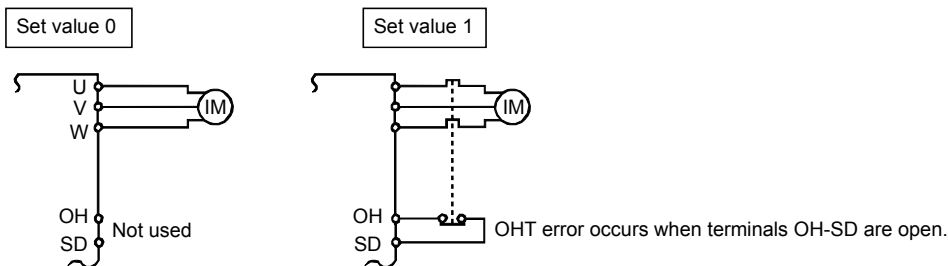

**CAUTION**

- When two or more motors are connected to the inverter under V/F control, they cannot be protected by the electronic thermal relay function. Install an external thermal relay to each motor.
- When a difference between the inverter and motor capacities is large and the setting is small, the protective characteristics of the electronic thermal relay function will be deteriorated. In this case, use an external thermal relay.
- A special motor cannot be protected by the electronic thermal relay function. Use an external thermal relay.

**REMARKS**

- When running two motors with one inverter, you can set the electronic thermal relay function of each inverter.

Pr. 450 "second applied motor"	Pr. 9 "electronic thermal O/L relay"	Pr. 452 "second electronic thermal O/L relay"	First Motor Electronic Thermal Relay Function		Second Motor Electronic Thermal Relay Function	
			RT = OFF	RT = ON	RT = OFF	RT = ON
9999	0	9999	×	×	×	×
		0	×	×	×	×
		0.01 to 500	×	×	△	○
9999	Other than 0	9999	○	○	×	×
		0	○	△	×	×
		0.01 to 500	○	△	△	○
Other than 9999	0	9999	×	×	×	×
		0	×	×	×	×
		0.01 to 500	×	×	△	○
Other than 9999	Other than 0	9999	○	△	△	○
		0	○	△	×	×
		0.01 to 500	○	△	△	○

○... Output current value is used to perform integration processing.

△... Output current is assumed as 0A to perform integration processing. (cooling processing)

×

- It is valid for controlling one motor with one inverter in two different control systems.
- It is valid for controlling the first motor with an external thermal relay and the second motor with an electronic thermal relay function.

**Related parameters**

- When constant-torque motor is used ⇒ Pr. 71 "applied motor", Pr. 450 "second applied motor" (Refer to page 111.)
- Use of second motor ⇒ Pr. 450 "second applied motor" (Refer to page 111.)
- RT signal setting ⇒ Set "3" in any of Pr. 180 to Pr. 183 and Pr. 187 (input terminal function selection). (Refer to page 150.)

### 3.4 Standard operation functions (Pr. 10 to Pr. 16)

#### 3.4.1 DC injection brake operation (Pr. 10, Pr.11 speed torque , Pr. 12, Pr.802 speed position )

By setting the DC injection brake voltage (torque) at a stop, operation time and operation starting speed, the stopping accuracy of positioning operation, etc. or the timing of applying the DC injection brake to stop the braking torque and the motor is adjusted.

Parameter	Name	Factory Setting	Setting Range	Remarks	
10	DC injection brake operation speed	15r/min	0 to 1500 r/min, 9999	9999: Operated at or below Pr. 13 value.	
11	DC injection brake operation time	0.5s	0 to 0.5s	Extended mode	
12	DC injection brake voltage	4%/2% (7.5K or less/11K or more)	0 to 30%		Use during V/F control.
802	Pre-excitation selection	0	0, 1		Use during speed control.

#### <Setting>

- Use Pr. 10 to set the speed at which the DC injection brake application is started.  
By setting "9999", the brake is operated at or below the speed set in Pr. 13.
- When stopping the motor by using a STOP key or turning the STF/STR off, the DC injection brake application is started at the speed set in Pr.10. When stopping the motor by setting speed to 0r/min (with PU or Volume), the DC injection brake application is started at the speed set in Pr.13.
- Use Pr. 11 to set the duration period the brake is applied. During this period, DC injection brake operation is exercised.  
When this period has elapsed, the motor is coasted to a stop.
- Use Pr. 12 to set the percentage to the power supply voltage. (Use this parameter only during V/F control.)  
When using the inverter dedicated motor (Mitsubishi constant-torque motor SF-JRCA and Mitsubishi energy saving motor SF-HR, SF-HRCA), change the Pr. 12 setting as follows:
  - SF-JRCA: 3.7K or less ... 4%, 5.5K or more ... 2%
  - SF-HR, SF-HRCA: 3.7K or less ... 4%, 5.5K, 7.5K ... 3%, 11K or more ... 2%

#### REMARKS

- For the 5.5K and 7.5K, the Pr. 12 setting is automatically changed to 2% if Pr. 71 "applied motor" value is set to the Mitsubishi constant torque motor. To the contrary, the Pr. 12 setting is changed to 4% if the Pr. 71 value is set to the general purpose motor.

Select either 0 speed control or servo lock control for brake operation when pre-excitation is performed with the LX signal using Pr.802.

Turning on the LX signal enables the pre-excitation operation. (valid only during speed control)

Parameter	Name	Description
802	Pre-excitation selection	0: 0 speed control (factory setting) Even under load, an attempt is made to maintain 0r/min to keep the motor shaft stopped. Note that if the shaft is overcome and turned by external force, it does not return to the original position. Position control is not exercised and only speed control is carried out to perform operation.
		1: Servo lock Even under load, an attempt is made to maintain the motor shaft position. Note that if the shaft is turned by external force, it returns to the original position after the external force has gone away. Since position control is exercised, you can adjust this position loop gain using Pr. 422 "position loop gain".

● Relationship between DC injection brake operation and pre-excitation operation in each control mode

Control Mode	Operation			
	LX terminal OFF (Deceleration to stop)		LX terminal ON	
	Pre-excitation selection Pr. 802 = 0	Pre-excitation selection Pr. 802 = 1	Pre-excitation selection Pr. 802 = 0	Pre-excitation selection Pr. 802 = 1
V/F control	DC injection brake	DC injection brake	No operation	No operation
Speed control (vector control)	0 speed control	Servo lock	0 speed control	Servo lock
Position control (vector control)	No operation	No operation	Servo lock	Servo lock

● The control block diagram during pre-excitation

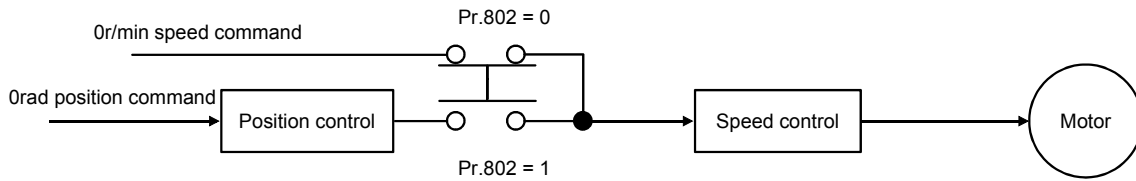

● Timing chart

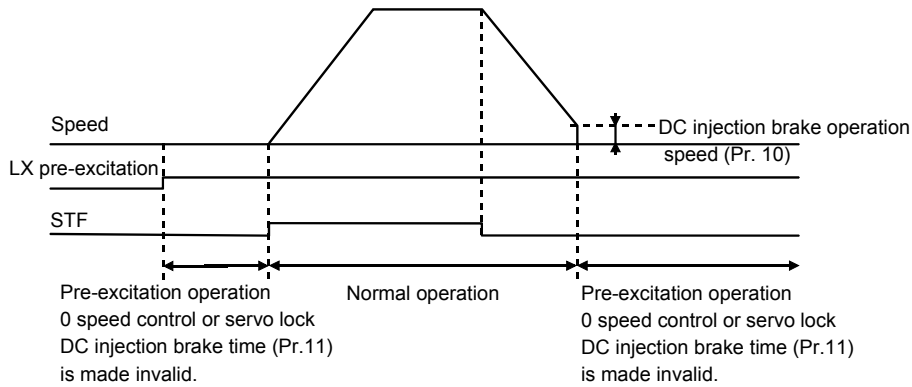

\* When the LX (pre-excitation) terminal is off, the pre-excitation operation functions for the time set in the DC injection brake operation time (Pr. 11).

**CAUTION**

The DC injection brake functions during speed limit under speed control or torque control. (It does not function under position control.)

**⚠ CAUTION**

⚠ Install a mechanical brake.  
After the machine stops fully and the mechanical brake is applied, switch the LX signal (pre-excitation) off.

**Related parameters**

- DC injection brake operation speed when Pr. 10 = 9999 ⇒ Pr. 13 "starting speed" (Refer to page 84.)
- Motor setting when using constant-torque motor ⇒ Pr. 71 "applied motor", Pr. 450 "second applied motor" (Refer to page 111.)
- Setting control mode ⇒ Pr. 800 "control system selection" (Refer to page 169.)
- LX signal terminal assignment ⇒ Set "23" in any of Pr. 180 to Pr. 183 and Pr. 187 (input terminal function selection). (Refer to page 150.)

3.4.2 Starting speed (Pr. 13 speed torque )

You can set the starting speed at which the start signal is turned on.

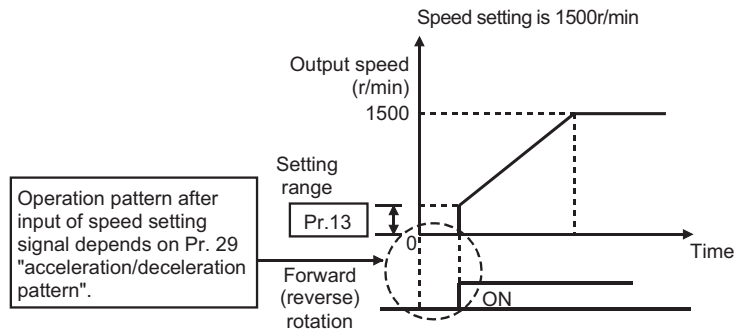

Parameter	Name	Factory Setting	Setting Range	Remarks
13	Starting speed	15r/min	0 to 1500r/min	Extended mode

**CAUTION**

- If the speed setting signal is less than the value set in Pr. 13 "starting speed", the operation is either 0 speed or servo lock.  
For example, when 150r/min is set in Pr. 13, the motor will start running when the speed setting signal reaches 150r/min.
- When the analog voltage command (example: across 2-5) is used as speed for operation, too low of a setting of the rotation speed at a start may start the motor running by merely entering the start signal although the voltage command is zero. In this case, adjustment can be made using the calibration function, Pr. 902.

**⚠ CAUTION**

⚠ When the Pr. 13 setting is equal to or less than the Pr. 2 "minimum speed" value, note that merely switching on the start signal will start the motor at the preset speed if the command speed is not input.

**Related parameters**

- Minimum speed setting ⇒ Pr. 2 "minimum speed" (Refer to page 76.)
- Acceleration/deceleration pattern setting ⇒ Pr. 29 "acceleration/deceleration pattern" (Refer to page 89.)
- Adjustment for analog voltage command ⇒ Pr. 902 "speed setting terminal 2 bias" (Refer to page 190.)

### 3.4.3 Jog operation (Pr. 15, Pr. 16 speed torque )

To start/stop jog operation in the external operation mode, choose the jog operation function in input terminal function selection, turn on the jog signal, and turn on/off the start signal (STF, STR).

When using the parameter unit (FR-PU04V), choose

the jog operation mode and use FWD or REV to perform jog operation.

(When the FR-PU04V is connected, these parameters can be read as the basic parameters.)

Perform PU jog operation using PU (FR-DU04-1, FR-PU04V) in the PU jog operation mode.

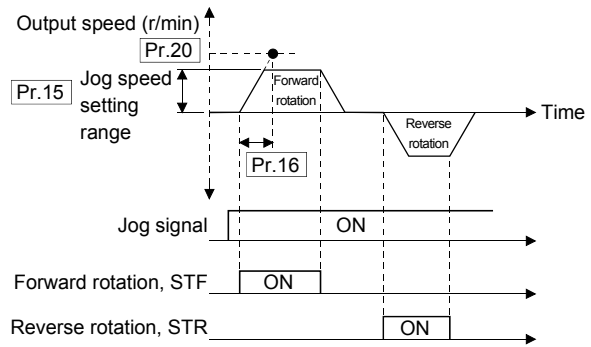

- Set the speed and acceleration/deceleration time for jog operation.

Parameter	Name	Factory Setting	Setting Range	Remarks
15	Jog speed setting	150r/min	0 to 1500r/min	Extended mode
16	Jog acceleration/ deceleration time	0.5s	0 to 3600s 0 to 360s	

#### REMARKS

For the operation method from the control panel (FR-DU04-1), refer to the Instruction Manual (basic).

#### CAUTION

- The acceleration time and deceleration time cannot be set separately for jog operation.
- The Pr. 15 "jog speed setting" value should be equal to or higher than the Pr. 13 "starting speed" setting.
- Assign the jog signal to any of Pr. 180 to Pr. 183 and Pr. 187 (input terminal function selection).
- The priorities of the external terminals for speed commands are:  
Jog > multi-speed operation > terminal 2
- During jog operation, the RT and X9 signals cannot be used to switch to the second and third acceleration/deceleration time.
- Under torque control, the jog speed acts as the speed limit value by turning on the jog signal.
- Jog operation is invalid under position control.
- When Pr. 79 "operation mode selection" = "4", push FWD / REV of the PU (FR-DU04-1/FR-PU04V) to make a start or push STOP  
RESET to make a stop.

#### Related parameters

- Jog signal terminal assignment ⇒ Set "5" in any of Pr. 180 to Pr. 183, Pr. 187 (input terminal function selection) (Refer to page 150.)
- S-shaped acceleration/deceleration pattern A ⇒ Pr. 29 "acceleration/deceleration pattern" (Refer to page 89.)
- Pr. 16 setting range, minimum setting increments condition setting ⇒ Pr. 21 "acceleration/deceleration time increments" (Refer to page 78.)

### 3.5 Operation selection functions 1 (Pr. 17 to Pr. 37)

#### 3.5.1 Inverter output stop (MRS) (Pr. 17 speed torque position)

The setting of this parameter needs to be changed to:

- Stop the motor with a mechanical brake (e.g. electromagnetic brake);
- Provide interlocks to prevent the inverter from running if the start signal is input to the inverter; or
- Coast the motor to a stop.

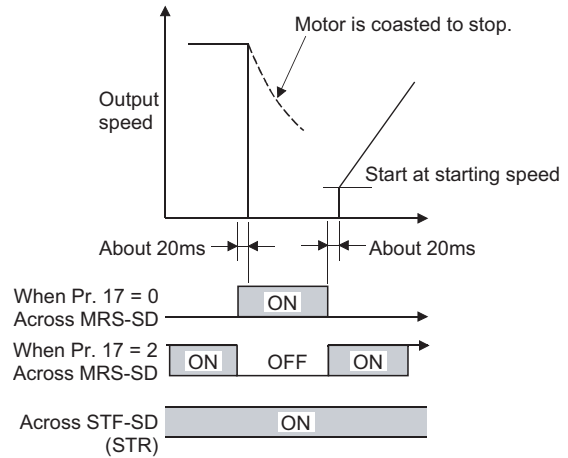

Parameter	Name	Factory Setting	Setting Range	MRS Signal Specifications	Remarks
17	MRS input selection	0	0	Output stops when MRS signal turns on.	Extended mode
			2	Output stops when MRS signal turns off. (NC contact input specifications)	

#### <Wiring example> For sink logic

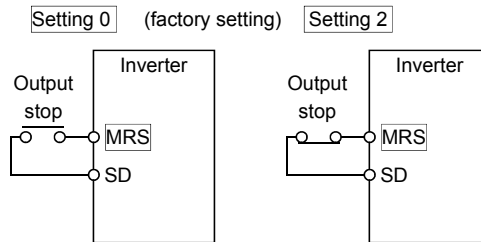

#### REMARKS

- Set the MRS signal using the input terminal function selection (Pr. 180 to Pr. 183, Pr. 187).
- The setting cannot be changed during operation.
- Refer to the Instruction Manual (basic) for inverter reset.

#### CAUTION

- When Pr. 30 = 2 (FR-HC connection), use the X10 signal.
- When the operation mode is the NET mode and Pr. 338 = 0, the MRS signal is used as both the external terminal and communication-based signals, and the output stops when either signal turns on. At the Pr. 17 setting of 2, the output stops when either signal turns off. (Oppositely, at the Pr. 17 setting of 2, both the external terminal and communication-based signals should turn on to make a start.)

#### Related parameters

- Starting speed setting ⇒ Pr. 13 "starting speed" (Refer to page 84.)
- MRS signal terminal assignment ⇒ Pr. 180 to Pr. 183, Pr. 187 (input terminal function selection) (Refer to page 150.)

Pr. 19 Refer to Pr. 3 (page 77)

Pr. 20, Pr. 21 Refer to Pr. 7, Pr. 8 (page 78)

**3.5.2 Torque limit (Pr. 22 speed position , Pr. 803 speed torque position , Pr. 810 to Pr. 817 speed position )**

Used to restrict the output torque to the predetermined value during speed control.  
For details of the setting method, refer to the torque limit of the Instruction Manual (basic).

Parameter	Name	Factory Setting	Setting Range	Remarks		
22	Torque limit level (*1)	150%	0 to 400%	When Pr. 810 = 0, 1st quadrant Pr. 22 2nd quadrant Pr. 812 3rd quadrant Pr. 813 4th quadrant Pr. 814		
803	Constant power range torque characteristic selection	0	0	Constant power limit (torque current limit and control)		
			1	Constant torque limit (torque limit and control(*3))		
810	Torque limit input method selection	0	0	Internal torque limit Parameter-set torque limit operation is performed.		
			1	External torque limit Torque limit based on the analog voltage from terminal 3		
811	Set resolution switchover	0	0	Speed setting and running speed monitor increments from the RS-485 communication or communication option.	Torque limit setting increments Pr. 22, Pr. 812 to Pr. 817	
			1	1r/min		0.1%
			10	0.1r/min		0.01%
			11	1r/min		
812	Torque limit level (regeneration)	9999	0 to 400%, 9999	Valid in the regeneration mode when Pr. 810 = 0. 9999: Pr. 22 value is used for limit.		
813	Torque limit level (3rd quadrant)	9999	0 to 400%, 9999	Valid in the reverse rotation driving mode when Pr. 810 = 0. 9999: Pr. 22 value is used for limit.		
814	Torque limit level (4th quadrant)	9999	0 to 400%, 9999	Valid in the regeneration mode when Pr. 810 = 0. 9999: Pr. 22 value is used for limit.		
815	Torque limit level 2	9999	0 to 400%, 9999	When the torque limit selection (TL) signal is on, Pr. 815 is used as the torque limit value regardless of Pr. 810. Valid when torque limit selection (TL) terminal input is provided. 9999: Depending on Pr. 22 setting		
816	Acceleration torque limit level (*2)	9999	0 to 400%, 9999	Set the torque limit value during acceleration. 9999: Same torque limit as at constant speed		
817	Deceleration torque limit level (*2)	9999	0 to 400%, 9999	Set the torque limit value during deceleration. 9999: Same torque limit as at constant speed		

Extended mode

**CAUTION**

- \*1.Output current level (stall prevention function) is activated to prevent the inverter from alarm stop due to overcurrent etc. during V/F control. When "0" is set in Pr. 22, stall prevention function is invalid.
- \*2.Pr. 816 "acceleration torque limit level" and Pr. 817 "deceleration torque limit level" are invalid during position control.
- \*3.For torque limit and torque control, torque is restricted and controlled not by magnetic flux.

**<Details>**

Torque limit is activated so that the output torque does not exceed the predetermined value during speed control. The block diagram is shown below. The output of speed control is suppressed within the torque limit value.

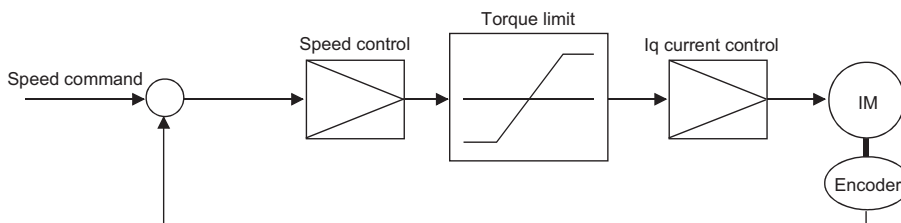

At this time, set Pr. 810 to select the way to make torque limit.



**<Setting>**

Pr. 810 Setting	Torque Limit Input Method	Operation
0	Internal torque limit	Parameter-set torque limit operation is performed. Changing the torque limit parameter value by communication enables torque limit to be adjusted by communication.
1	External torque limit	Torque limit using the analog voltage from terminal 3 is made valid.

**REMARKS**



Refer to the Instruction Manual (basic) for details of the other parameters.

**CAUTION**

Whether the torque limit in the constant power range is set to constant torque limit or constant power limit in the torque limit setting depends on the setting of Pr. 803 "constant power range torque characteristic selection".

**Related parameters**

- Torque command bias adjustment ⇒ Pr. 904 "torque command terminal 3 bias" (Refer to page 190.)
- Torque command gain adjustment ⇒ Pr. 905 "torque command terminal 3 gain" (Refer to page 190.)

**Pr. 24 to Pr. 27** ➔ Refer to Pr. 4 to Pr. 6 (page 77)

**3.5.3 RH, RM, RL signal input compensation (Pr. 28 speed torque )**

By entering 0 to ±10V into terminal 1 (speed setting auxiliary terminal), the speeds of the RH, RM and RL signals (command speeds for multi-speed operation) can be compensated for.

Parameter	Name	Factory Setting	Setting Range	Description	Remarks
28	Multi-speed input compensation	0	0	Without compensation	Extended mode
			1	With compensation	

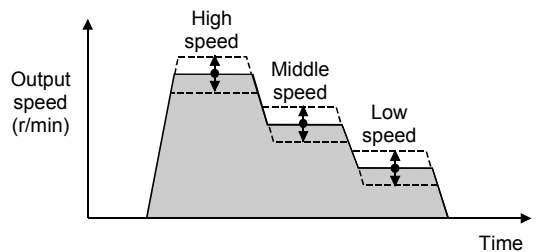

**CAUTION**

- When "4 or 14" is set in Pr. 73, the compensation signal is input from terminal 2, not from terminal 1. (Override function)
- Since terminal 1 is a multi-function selection terminal, its function varies with the Pr. 868 setting. Set "0" in Pr. 868. Refer to Pr. 902 and Pr. 903 for calibration of the terminal 1.

**Related parameters**

- Multi-speed setting ⇒ Pr. 4 to Pr. 6, Pr. 24 to Pr. 27, Pr. 232 to Pr. 239 (multi-speed setting) (Refer to page 77.)
- RH, RM, RL signals ⇒ Pr. 180 to Pr. 183, Pr. 187 (input terminal function selection) (Refer to page 150.)
- Speed compensation using terminal 2 ⇒ Pr. 73 "speed setting signal" (Refer to page 113.)
- Function assignment to terminal 1 ⇒ Set "0" in Pr. 868 "terminal 1 function assignment" (Refer to page 183.)
- Pr. 59 "remote setting function selection" ⇒ Refer to page 103.
- Calibration of terminal 1 ⇒ Pr. 902 "speed setting terminal 2 bias", Pr. 903 "speed setting terminal 2 gain" (Refer to page 190)

**3.5.4 S-pattern acceleration/deceleration curve (Pr. 29, Pr. 140 to Pr. 143, Pr. 380 to Pr. 383 ( speed torque )**

When you have changed the preset speed during start, acceleration, deceleration, stop, or operation, you can change the running speed by acceleration/deceleration to make adjustment to reach the preset speed. Set the acceleration/deceleration pattern in Pr. 29 "acceleration/deceleration pattern".

Parameter	Name	Factory Setting	Setting Range	Remarks
29	Acceleration/ deceleration pattern	0	0	Linear acceleration/deceleration
			1	S-pattern acceleration/deceleration A
			2	S-pattern acceleration/deceleration B
			3	Backlash measures acceleration/ deceleration
			4	S-pattern acceleration/deceleration C
140	Backlash acceleration stopping speed	30r/min	0 to 3600r/min	Accessible when Pr. 29 = 3
141	Backlash acceleration stopping time	0.5s	0 to 360s	
142	Backlash deceleration stopping speed	30r/min	0 to 3600r/min	
143	Backlash deceleration stopping time	0.5s	0 to 360s	
380	Acceleration S pattern 1	0%	0 to 50%	Accessible when Pr. 29 = 4
381	Deceleration S pattern 1	0%	0 to 50%	
382	Acceleration S pattern 2	0%	0 to 50%	
383	Deceleration S pattern 2	0%	0 to 50%	

Extended mode

**<Setting>**

Pr. 29 Setting	Function	Description	Operation
0	Linear acceleration/ deceleration (factory setting)	Acceleration/deceleration is made linearly up/down to the preset speed .	
1	S-pattern acceleration/ deceleration A (torque variation technique)	<p>The motor torque is utilized effectively to make fast acceleration/deceleration in a large motor-generated torque area and smooth acceleration/deceleration in a small motor-generated torque area. In this acceleration/deceleration pattern, the base frequency is the inflection point of an S shape, and you can set the acceleration/deceleration time according to the reduction in motor torque in the constant-power operation range at higher than the rated speed. This function is valid for V/F control only. For other than V/F control, linear acceleration/deceleration is made.</p> <p style="text-align: center;"><b>CAUTION</b></p> <p><b>As the acceleration/deceleration time, set the time taken to reach Pr. 3 "base frequency", not Pr. 20 "acceleration/deceleration reference speed".</b></p>	
2	S-pattern acceleration/ deceleration B (shock absorption)	<p>For prevention of load shifting in conveyor and other applications This setting always provides S-pattern acceleration/ deceleration from s2 (current speed) to s1 (preset speed), easing an acceleration/deceleration shock and producing an effect on the prevention of load shifting in conveyor and other applications.</p>	
3	Backlash measures acceleration/ deceleration	<p>Backlash measures for reduction gear, etc. This function stops a speed change temporarily during acceleration/deceleration, reducing a shock generated when a reduction gear backlash is eliminated suddenly. Use Pr. 140 to Pr. 143 to set the stopping times and stopping speed in accordance with the chart on the right. The acceleration/deceleration time is increased by the stopping time.</p> <p><b>REMARKS</b></p> <p>Output speed is retained for the time for the starting speed (Pr. 13) and <math>\Delta s1</math> (Pr. 140) time at a start and accelerate again after <math>\Delta t1</math> time has elapsed. Speed reaches or below <math>\Delta s2</math> (Pr. 142) is retained for <math>\Delta t2</math> (Pr. 143) time at a start of deceleration and decelerate again after <math>\Delta t2</math> time has elapsed.</p>	
4	S-pattern acceleration/ deceleration C	See next page.	See next page.

**REMARKS**

For the acceleration/deceleration time, turning on the RT signal makes Pr. 44 "second acceleration/deceleration time" and Pr. 45 "second deceleration time" valid (turning on the X9 signal makes Pr. 110 and Pr. 111 valid). Refer to page 78.

**Pr. 29 = 4 (S-pattern acceleration/deceleration C)**

With the S-pattern acceleration/deceleration C switch signal (X20), an acceleration/deceleration curve S-pattern 1 or S-pattern 2 can be selected.

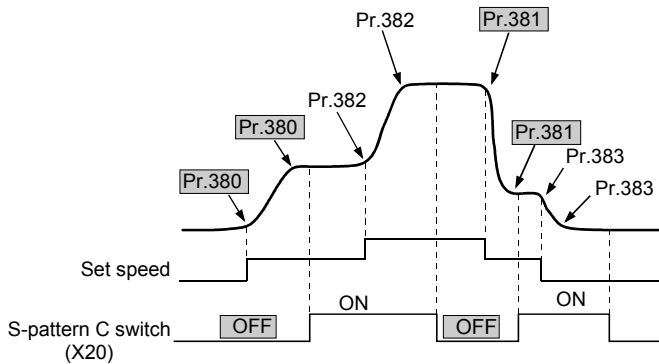

**CAUTION**

Change the S pattern acceleration/ deceleration C switch (X20) after the speed becomes constant. S pattern operation before switching continues even if the X20 is changed during acceleration or deceleration.

Operation X20 Signal	During Acceleration	During Deceleration
OFF	Pr. 380 "acceleration S pattern 1"	Pr. 381 "deceleration S pattern 1"
ON	Pr. 382 "acceleration S pattern 2"	Pr. 383 "deceleration S pattern 2"

As the acceleration/deceleration time during acceleration/deceleration, set the percentage to the acceleration/ deceleration time T in Pr. 380 to Pr. 383.

Parameter setting (%) =  $T_s / T \times 100\%$

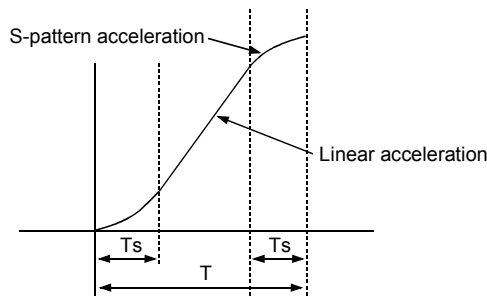

**REMARKS**

- At a start, the motor starts at Pr. 13 "starting speed" when the start signal turns on.
- If there is a difference between the speed command and speed at a start of deceleration due to torque limit operation etc., the speed command is matched with the speed to make deceleration.

**Related parameters**

- Base frequency setting (acceleration/deceleration time setting) ⇒ Pr. 3 "base frequency" (Refer to page 77.)
- Pr. 20 "acceleration/deceleration reference speed" ⇒ Refer to page 78.
- X20 signal setting when Pr. 29 = 4 (S-pattern acceleration/deceleration switch) ⇒ Pr. 180 to Pr. 187 (input terminal function selection) (Refer to page 150.)
- Starting speed setting ⇒ Pr. 13 "starting speed" (Refer to page 84.)

**3.5.5 Regenerative brake duty (Pr. 30, Pr. 70 speed torque position)**

- When making frequent starts/stops in a 15K or less inverter, use the optional "high-duty brake resistor (FR-ABR)" to increase the regenerative brake duty.
- Use the optional "high power factor converter (FR-HC) or power regeneration common converter (FR-CV)" to reduce harmonics, improve the power factor, or continuously use the regenerative mode.

Parameter	Name	Factory Setting	Setting Range	Remarks
30	Regenerative function selection	0	0	When using built-in brake resistor or brake unit (Type FR-BU, BU)
			1	When using the high-duty brake resistor (FR-ABR)
			2	When using the high power factor converter (FR-HC) or power regeneration common converter (FR-CV)
70	Special regenerative brake duty	0%	0 to 15%	1.5K
			0 to 30%	2.2K or more

**<Setting>**

- When using the built-in brake resistor, brake unit or power regeneration converter  
Set "0" in Pr. 30. The Pr. 70 setting is made invalid.  
At this time, the regenerative brake duty is as follows.
  - FR-V520-1.5K to 3.7K..... 3%
  - FR-V520-5.5K..... 2%
  - FR-V520-7.5K or more..... 0% (without a built-in brake resistor)
  - FR-V540-1.5K to 5.5K..... 2%
  - FR-V540-7.5K or more..... 0% (without a built-in brake resistor)
- When using the high-duty brake resistor (FR-ABR)
  - Set "1" in Pr. 30.
  - Set Pr.70 "special regenerative brake duty" as follows:  
7.5K or less . . . .10%  
11K or more . . .6%
- When using the high power factor converter (FR-HC) or power regeneration common converter (FR-CV)
  - Set "2" in Pr. 30.
  - Use any of Pr. 180 to Pr. 183 and Pr. 187 to assign the following signals to the contact input terminals.
    - X10: FR-HC connection, FR-CV connection (inverter operation enable signal)  
To make protective coordination with the high power factor converter (FR-HC) or power regeneration common converter (FR-CV), use the inverter operation enable signal to shut off the inverter output. Enter the RDY signal of the high power factor converter or power regeneration common converter.
    - X11: FR-HC connection (instantaneous power failure detection signal)  
When the computer link plug-in option (FR-A5NR) is used and the setting is made to hold the pre-instantaneous power failure mode, use this signal to hold that mode. Enter the instantaneous power failure detection signal of the high power factor converter.
  - The Pr. 70 setting is made invalid.

**CAUTION**

Set "10" and "11" in any of Pr. 180 to Pr. 183 and Pr. 187 to assign the terminals used to input the X10 and X11 signals.

**⚠ WARNING**

⚠ The value set in Pr. 70 must not exceed the setting of the brake resistor used. Otherwise, the resistor can overheat.

**REMARKS**

- The Pr. 70 setting is invalid for the inverter of 18.5K or more.
- Pr. 70 "regenerative brake duty" indicates the %ED of the built-in brake transistor operation.

**Related parameters**

- X10, X11 signal terminal assignment ⇒ Pr. 180 to Pr. 183, Pr. 187 (input terminal function selection) (Refer to page 150.)

**CAUTION**

Changing the terminal assignment with any of Pr. 180 to 183 and Pr. 187 may affect the other functions. Please make setting after confirming the function of each terminal.

3.5.6 Speed jump (Pr. 31 to Pr. 36 speed torque )

When it is desired to avoid resonance attributable to the natural frequency of a mechanical system, these parameters allow resonance occurrence speeds to be jumped. Up to three areas may be set, with the jump speeds set to either the top or bottom point of each area. The value set to 1A, 2A or 3A is a jump point and operation is performed at this speed.

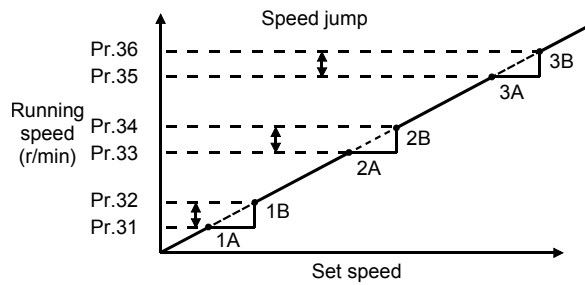

Parameter	Name	Factory Setting	Setting Range	Remarks
31	Speed jump 1A	9999	0 to 3600r/min, 9999	<ul style="list-style-type: none"> <li>• 9999: Function invalid</li> <li>• Extended mode</li> </ul>
32	Speed jump 1B	9999	0 to 3600r/min, 9999	
33	Speed jump 2A	9999	0 to 3600r/min, 9999	
34	Speed jump 2B	9999	0 to 3600r/min, 9999	
35	Speed jump 3A	9999	0 to 3600r/min, 9999	
36	Speed jump 3B	9999	0 to 3600r/min, 9999	

<Setting>

- To fix the speed at 600r/min between Pr. 33 and Pr. 34 (600r/min and 700r/min), set 600r/min in Pr. 33 and 700r/min in Pr. 34.
- To jump to 700r/min between 600r/min and 700r/min, set 700r/min in Pr. 33 and 600r/min in Pr. 34.

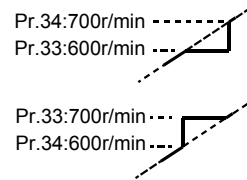

**CAUTION**

During acceleration/deceleration, the running speed within the set area is valid.

**REMARKS**

If the speed jump setting ranges overlap, a write disable error "Err" appears.

3.5.7 Speed display (Pr. 37, Pr. 144, Pr. 505 speed torque position )

The units of the running speed monitor display of the PU (FR-DU04-1/FR-PU04V), the running speed/frequency setting in the PU operation mode, and the parameter setting unit used for frequency setting can be changed from the frequency to the motor speed or machine speed.

Parameter	Name	Factory Setting	Setting Range	Remarks
37	Speed display	0	0	Output speed
			1 to 9998	Machine speed at the Pr. 505 set speed operation
144	Speed setting switchover	0	0, 2, 4, 6, 8, 10	Number of motor poles
505	Speed setting reference	1500r/min	1 to 3600r/min	Reference speed for Pr. 37

Extended mode

## Operation selection functions 1 (Pr. 17 to Pr. 37)

### <Setting>

- To display the machine speed, set in Pr. 37 "speed display" the machine speed to be displayed during the Pr. 505 speed operation.  
For example, when Pr. 505 = 1800r/min and Pr. 37 = 1000, the speed monitor displays "1000" at the operation speed of 1800r/min. The monitor displays "500" at the operation speed of 900r/min.
- To display the motor frequency, set the number of motor poles (2, 4, 6, 8, 10) in Pr. 144.
- When the running speed monitoring has been selected, the parameter setting unit and the running speed setting in the PU operation mode depend on the combination of the Pr. 37 and Pr. 144 settings as indicated below:

Pr. 37	Pr. 144	Running Speed Monitor	Preset Speed Monitor	Output Frequency Monitor	Running Speed Setting/Pr. Setting
0	0	r/min	r/min	Hz Pr. 81, Pr. 454	r/min
	2 to 10	Hz Pr. 144	Hz Pr. 144	Hz Pr. 144	Hz Pr. 144
1 to 9998	0	Machine speed Pr. 37	Machine speed Pr. 37	Hz Pr. 81, Pr. 454	r/min
	2 to 10	Machine speed Pr. 37	Machine speed Pr. 37	Hz Pr. 81, Pr. 454	Machine speed Pr. 37

### CAUTION

- When Pr. 37 and Pr. 144 are combined to select the Hz setting, the number of poles set in Pr. 144 is used to calculate the frequency, independently of the number of motor poles (Pr. 81, Pr. 454) used for control.  
Note this when the number of motor poles (Pr. 81, Pr. 454) differs from Pr. 144.
- When the speed setting has been selected, operation is performed at the synchronous speed.  
When 4 poles and 60Hz are set, operation is performed at 1800r/min. For V/F control, the output frequency is 60Hz.
- To change the PU main monitor (PU main display) or PU level meter (PU level display), refer to Pr. 52 and Pr. 53.
- As the control panel display is 4 digits, "-- --" is displayed when the monitored value exceeds "9999".
- Even if the machine speed is set to be displayed, the minimum setting increments of parameter is calculated in 1r/min (0.1r/min) increments. Therefore, the value is rounded off when it is smaller than the minimum setting increments of the parameter.

## CAUTION

-  Make sure that the settings of the running speed and number of motor poles are correct. Otherwise, the motor might run at extremely high speed, damaging the machine.

### Related parameters

- PU main monitor changing ⇒ Pr. 52 "DU/PU main display data selection" (Refer to page 97.)
- PU level meter changing ⇒ Pr. 53 "PU level display data selection" (Refer to page 97.)
- Setting of number of motor poles ⇒ Pr. 81 "number of motor poles", Pr. 454 "number of second motor poles" (Refer to page 120.)

### 3.6 Output terminal functions (Pr. 41 to Pr. 50)

#### 3.6.1 Up-to-speed sensitivity (Pr. 41 speed )

You can adjust the ON range of the up-to-speed signal (SU) output when the output speed reaches the running speed.

This parameter can be used to confirm that the running speed has been reached and used as the operation start signal etc. for related equipment.

- Under vector control with encoder: Actual motor speed (feedback value) is adjusted.

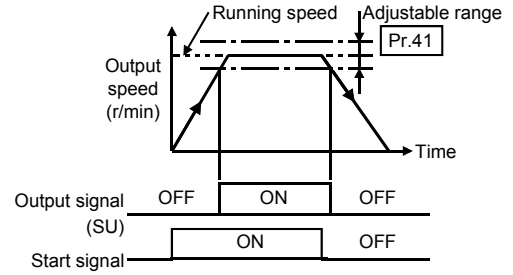

Parameter	Name	Factory Setting	Setting Range	Remarks
41	Up-to-speed sensitivity	10%	0 to 100%	Extended mode

#### REMARKS

- Assign functions to the terminals DO1 to DO3 and ABC to use the SU signal. The SU signal is assigned to the terminal DO2 when shipped from the factory. Use any of Pr. 190 to Pr. 192 and Pr. 195 to change the terminal functions. Changing the terminal assignment with any of Pr. 190 to Pr. 192 and Pr. 195 may affect the other functions. Check the functions of the corresponding terminals before making setting. (Refer to page 152.)
- For V/F control, the motor runs at the speed converted from the output frequency.

#### Related parameters

- SU signal terminal assignment ⇒ Set "1" in any of Pr. 190 to Pr. 192 and Pr. 195 (output terminal function selection) (Refer to page 152.)

#### 3.6.2 Speed detection (Pr. 42, Pr. 43, Pr. 50, Pr. 116 speed torque position )

When the speed reaches or exceeds the setting, the output speed detection signal (FU, FU2, FU3 signal) or speed detection signal (FB, FB2, FB3 signal) is output.

- This function can be used for electromagnetic brake operation, open signal, etc.
- You can also set speed detection used exclusively for reverse rotation.
- This function is effective for changing the timing of electromagnetic brake operation between forward rotation (rise) and reverse rotation (fall) during elevator operation, etc.
  - The FU signal is output when the speed has reached the output speed.
  - The FB signal is output when the speed has reached the detected actual motor speed (feedback value).

Parameter	Name	Factory Setting	Setting Range	Remarks
42	Speed detection	300r/min	0 to 3600r/min	_____
43	Speed detection for reverse rotation	9999	0 to 3600r/min, 9999	9999: Same as Pr. 42 setting
50	Second speed detection	750r/min	0 to 3600r/min	_____
116	Third speed detection	1500r/min	0 to 3600r/min	_____

#### (1) Signal operation

The FU, FU2 and FU3 signals function under speed/V/F control. They do not function under torque/position control.

	FU	FB
Compared signals	Speed command value	Actual motor speed
FU/FB signal	Forward rotation: On when speed is equal to or higher than in Pr. 42 Reverse rotation: On when speed is equal to or higher than in Pr. 43	
FU2/FB2 signal	On when speed is equal to or higher than in Pr. 50 (both forward and reverse) Off when speed is lower than in Pr. 50 (both forward and reverse)	
FU3/FB3 signal	On when speed is equal to or higher than in Pr. 116 (both forward and reverse) Off when speed is lower than in Pr. 116 (both forward and reverse)	

#### REMARKS

For V/F control, on/off control is exercised at the speed converted from the output frequency. (The detection actions of the FU and FB signals are the same.)



## Output terminal functions (Pr. 41 to Pr. 50)

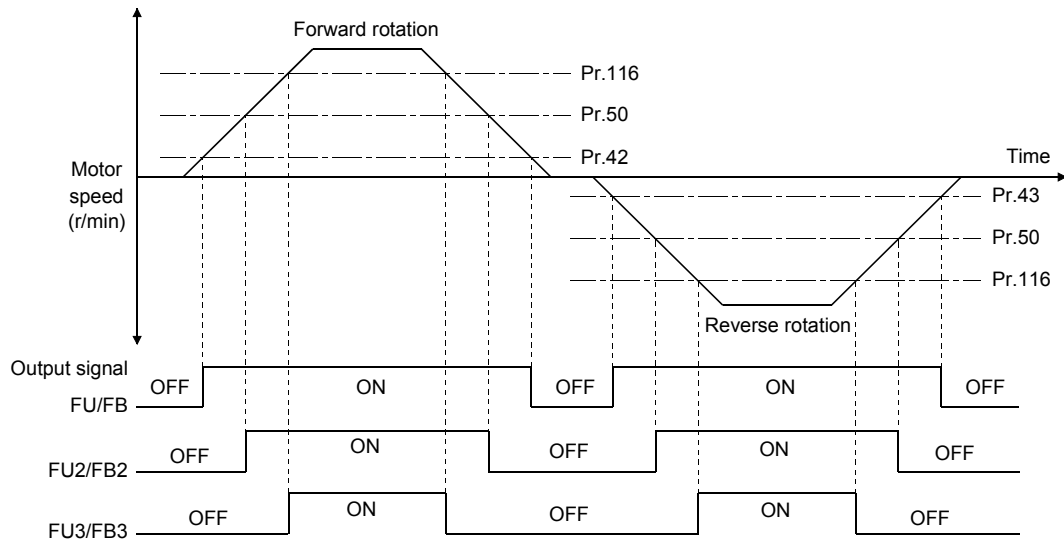

### REMARKS

The speed command value indicates the last speed command value given after acceleration/deceleration processing.

### CAUTION

- Assign functions to the terminals DO1 to DO3 and ABC to use the FU, FU2, FU3 and FB, FB2, FB3 signals. Use any of Pr. 190 to Pr. 192 and Pr. 195 to change the terminal functions. Changing the terminal assignment with Pr. 190 to Pr. 192 and Pr. 195 may affect the other functions. Check the functions of the corresponding terminals before making setting.
- The speed detection signal turns off when an inverter alarm occurs or when the reset terminal (MRS, RES signal) turns on.
- When any parameter setting is "0", the corresponding signal turns on as soon as the start signal turns on.

### Related parameters

- FB, FB2, FB3, FU, FU2, FU3 signal terminal assignment ⇒ Pr. 190 to Pr. 192, Pr. 195 (output terminal function selection) (Refer to page 152.)

**Pr. 44, Pr. 45** ➡ Refer to Pr. 7, Pr. 8 (page 78)

**Pr. 50** ➡ Refer to Pr. 42, Pr. 43 (page 95)

### 3.7 Display functions 1 (Pr. 52 to Pr. 56)

#### 3.7.1 Monitor display/DA1, DA2 terminal function selection

(Pr. 52 to Pr. 54, Pr. 158 speed torque position )

During operation, you can select the signals shown on the control panel (FR-DU04-1)/parameter unit (FR-PU04V) main display screen and on the parameter unit (FR-PU04V) level meter and the signals output to the DA1 and DA2 terminals.

- There are two analog output DA1 and DA2 terminals.  
Select the signals using Pr. 54 and Pr. 158.

Parameter	Name	Factory Setting	Setting Range	Remarks
52	DU/PU main display data selection	0	0, 5 to 12, 17 to 20, 23, 24, 32 to 35, 38, 100 (5 to 12 are invalid for FR-PU04V)	Extended mode
53	PU level display data selection	1	0 to 3, 5 to 12, 17, 18	
54	DA1 terminal function selection	1	1 to 3, 5 to 12, 17, 18, 21, 32 to 34, 36	
158	DA2 terminal function selection	1	1 to 3, 5 to 12, 17, 18, 21, 32 to 34, 36	

#### <Setting>

Any of the following signals can be monitored by parameter setting.  
The signals marked × cannot be selected for monitoring.

Signal Type	Display Unit	Parameter Settings					± Output	Full-Scale Value of the Level Meter Connected to DA1 and DA2	Description
		Pr. 52	Pr. 53	Pr. 54	Pr. 158				
		DU LED	PU main monitor	PU level meter	DA1 terminal 12 bits (±10V)	DA2 terminal 12 bits (+10V)			
No display	—	×	×	0	×		—	When "0" is set in Pr. 53, the level meter of the parameter unit is not displayed.	
Speed	0.1 r/min	0/100	0/100	1	1	○	Pr. 55	Vector control	Speed feedback value from encoder
								V/F control	Speed calculated from output frequency
Output current	0.01A	0/100	0/100	2	2	×	Pr. 56	The output current is displayed as effective value.	
Output voltage	0.1V	0/100	0/100	3	3	×	400V/800V	The output voltage is displayed as effective value.	
Alarm display	—	0/100	0/100	×	×	×	—	—	
Set speed	0.1 r/min	5	*2	5	5	×	Pr. 55	Under speed control, the current speed setting is displayed. 0r/min under position control.	
Output frequency	0.01 Hz	6	*2	6	6	○	The frequency converted from Pr. 55	The output frequency is displayed.	
Motor torque	0.1%	7	*2	7	7	○	Pr. 866	The output torque is displayed. The ratio to the rated torque is displayed. When the DA1 output monitor is used, a positive voltage is output during forward driving and reverse regeneration and a negative voltage is output during reverse driving and forward regeneration.	
Converter output voltage	0.1V	8	*2	8	8	×	400V/800V	DC bus voltage is displayed.	

**Display functions 1 (Pr. 52 to Pr. 56)**

Signal Type	Display Unit	Parameter Settings					± Output	Full-Scale Value of the Level Meter Connected to DA1 and DA2	Description
		Pr. 52		Pr. 53	Pr. 54	Pr. 158			
		DU LED	PU main monitor	PU level meter	DA1 terminal 12 bits (±10V)	DA2 terminal 12 bits (+10V)			
Regenerative brake duty	0.1%	9	*2	9	9	×	Pr. 70	The brake resistor duty is displayed.	
Electronic overcurrent protection load factor	0.1%	10	*2	10	10	×	Thermal relay operation level	The thermal relay load factor is displayed.	
Output current peak value	0.01A	11	*2	11	11	×	Pr. 56	The peak value of the output voltage is displayed as effective value.	
Converter output voltage peak value	0.1V	12	*2	12	12	×	400V/800V	The peak value of DC bus voltage is displayed.	
Input terminal status	—	×	*2	×	×	×	—	—	
Output terminal status	—	×	*2	×	×	×	—	—	
Load meter *1	0.1%	17	17	17	17	○	Pr. 866	The load meter is output.	
Motor excitation current	0.01A	18	18	18	18	×	Pr. 56	Pre-excitation current is displayed.	
Position pulse	—	19	19	×	×	×	—	The position of the motor output shaft is monitored.	
Cumulative energization time	1h	20	20	×	×	×	—	Cumulative energization time since the inverter shipment (power on time) is displayed. (Minimum increment is Hr)	
Reference voltage output	—	×	×	×	21	×	—	The voltage of DA1 and DA2 at full-scale is output	
Actual operation time	1h	23	23	×	×	×	—	The inverter running time is accumulated. (The time during a stop is not accumulated.) It is cleared using Pr. 171 "actual operation hour meter clear".	
Motor load factor	0.1%	24	24	×	×	×	—	The load factor to the rated motor capacity is displayed.	
Torque command*1	0.1%	32	32	×	32	○	Pr. 866	The torque command value is displayed.	
Torque current command*1	0.1%	33	33	×	33	○	Pr. 866	The torque current command value is displayed.	
Motor output *1	0.01 kW	34	34	×	34	○	Rated motor current	The machine output of the motor shaft end is displayed.	
Feedback pulse	—	35	35	×	×	×	—	The number of pulses feed back during 1 sampling is displayed. Display range is 0 to 99999 pulses. Sampling time for the following number of encoder pulses are: 1.0s for 1500 pls/rev or less; 0.5s for 1501 to 3200 pls/rev; and 0.25s for 3201 to 4096 pls/rev.	

Signal Type	Display Unit	Parameter Settings					± Output	Full-Scale Value of the Level Meter Connected to DA1 and DA2	Description	
		Pr. 52		Pr. 53	Pr. 54					Pr. 158
		DU LED	PU main monitor	PU level meter	DA1 terminal 12 bits (±10V)	DA2 terminal 12 bits (+10V)				
Torque monitor (driving/regenerative polarity switchover) *1	—	×	×	×	36		○	Pr. 866	The output torque is monitored. When the DA1 output monitor is used, a positive voltage is output during forward and reverse driving and a negative voltage is output during forward and reverse regeneration.	
Trace status	—	38	38	×	×		×	—	The trace status is displayed. 0: Stop 1: During pre-trigger 2: Waiting for trigger 3: During trace 4: Trace completion 101: During data output 102: Data output completion	

**CAUTION**

- \*1 When DA1 (Pr. 54) is selected, high response output is available. When DA2 (Pr. 158) is selected, average value is output.
- \*2 Select this monitor in "Others" of the FR-PU04V (option).

When "100" is set in Pr. 52, the monitored values during stop and during operation differ as indicated below. (The LED on the left of r/min flickers during stop, and is lit during operation.)

When Pr. 52 = "100", the set speed displayed at a stop indicates speed to be output when the start command is on. Different from the speed setting based on displayed when Pr. 52 = "5", the value maximum/minimum speed and speed jump is displayed.

	Pr. 52		
	0	100	
	During operation/ during stop	During stop	During operation
Speed	Speed	Set speed	Speed
Output current	Output current		
Output voltage	Output voltage		
Alarm display	Alarm display		

**REMARKS**

- During a reset, the values are the same as at a stop. During offline auto tuning, the tuning status monitor has priority.
- By setting "0" in Pr. 52, the monitoring of output speed to alarm display can be selected in sequence by the SHIFT key.
- \*Speed setting to output terminal status on the PU main monitor are selected by "other monitor selection" of the parameter unit (FR-PU04V).
- When Pr. 52 = any of "17, 18 and 24", the output current monitor changes to the set monitored data. When Pr. 52 = any of "19, 20, 23 and 32 to 35, 38", the output voltage monitor changes to the set monitored data.

**CAUTION**

1. The cumulative energization time and actual operation time are accumulated from 0 to 65535 hours, then cleared, and accumulated again from 0. When the control panel (FR-DU04-1) is used, more than 9999h is displayed as "----". Use the parameter unit (FR-PU04V) to confirm more than 9999h.
2. The cumulative energization time and actual operation time is not accumulated unless the inverter is run continuously for more than one hour.
3. When the control panel (FR-DU04-1) is used, the display unit is r/min, V or A only.

**REMARKS**

Where to monitor the data set in Pr. 52 varies with the setting.

**Factory setting**

\* The monitor displayed at powering on is the first monitor. To set the first monitor, press **SET** for more than 1.5s.

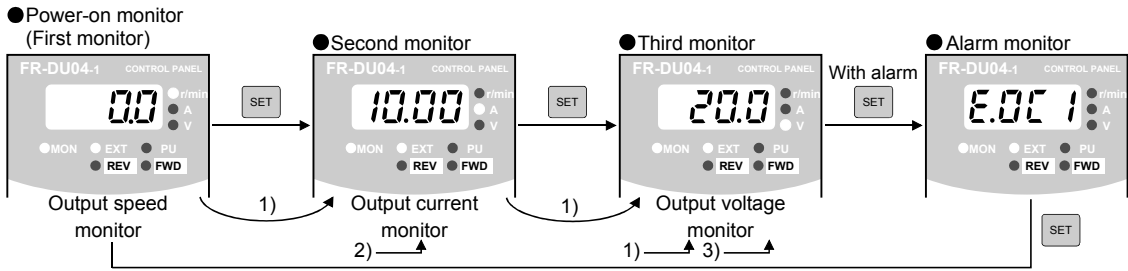

1) Setting is any of "5 to 12" (Displayed in the third monitor position)

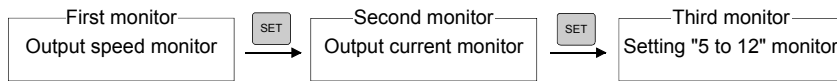

2) Setting is any of "17, 18 and 24" (Displayed instead of output current monitor)

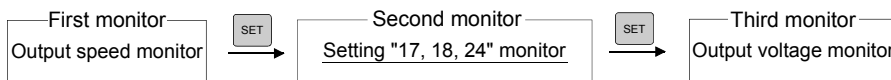

3) Setting is any of "19, 20, 23, 25" (Displayed instead of output voltage monitor)

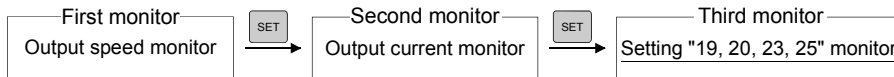

**Related parameters**

- Speed monitoring reference setting ⇒ Pr. 55 (Refer to page 100.)
- Current monitoring reference setting ⇒ Pr. 56 (Refer to page 100.)
- Torque monitoring reference setting ⇒ Pr. 866 (Refer to page 100.)
- Output filter of terminal DA1 ⇒ Pr. 867 (Refer to page 183.)

**3.7.2 Monitoring reference (Pr. 55, Pr. 56, Pr. 866 speed torque position)**

Set the value that is referenced when the output speed or output current is selected for the DA1 and DA2 terminals and PU level meter display.

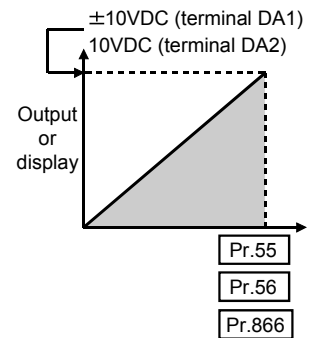

Parameter	Name	Factory Setting	Setting Range	Remarks
55	Speed monitoring reference	1500r/min	0 to 3600r/min	Extended mode
56	Current monitoring reference	Rated inverter current	0 to 500A	
866	Torque monitoring reference	150%	0 to 400%	

### 3.8 Automatic restart (Pr. 57, Pr. 58)

#### 3.8.1 Automatic restart after instantaneous power failure

(Pr. 57 speed torque, Pr. 58, Pr. 162 to Pr. 165)

At power restoration after an instantaneous power failure, you can restart the inverter without stopping the motor (with the motor coasting).

Parameter	Name	Factory Setting	Setting Range	Remarks
57	Restart coasting time	9999	0	Set to 0.1s.
			0.1 to 5s	
			9999	
58	Restart cushion time	1.0s	0 to 60s	Valid for V/F control
162	Automatic restart after instantaneous power failure selection	0	0	0: With speed search
			1	1: Without speed search
			10	10: Speed search initiated per start
				Valid for V/F control ("10" is valid for vector control also)
163	First cushion time for restart	0s	0 to 20s	Valid for V/F control
164	First cushion voltage for restart	0%	0 to 100%	
165	Restart current limit level	150%	0 to 200%	

Extended mode

**<When vector control is exercised>**

(The Pr. 162 setting "0, 1" is invalid under vector control.)

Instantaneous power failure (power failure) time

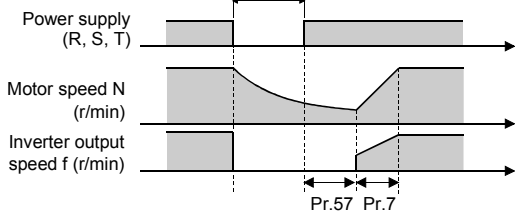

\* 0r/min when search speed is 15r/min or less.  
Pr.58 is invalid under vector control

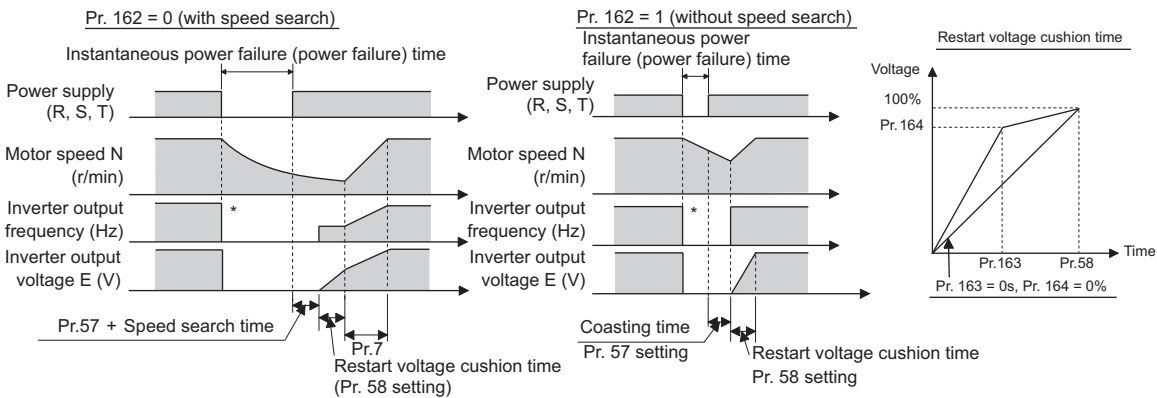

\* The output shut off timing differs according to the load condition.

**REMARKS**

When Pr. 162 = "1", the output speed before an instantaneous power failure is stored and output at the time of restart. If the power of the inverter control circuit is lost, the output speed before an instantaneous power failure cannot be stored and the inverter will start at 0r/min.

**<Setting>**

Refer to the above figures and following table to set the corresponding parameters.

Parameter Number	Setting	Description
57	0	0.1s coasting time   This setting may be used without problem during vector control.
	0.1 to 5s	Waiting time for inverter-triggered restart after power is restored from an instantaneous power failure. (Set this time between 0.1s and 5s according to the magnitude of the moment (J) of inertia of the load and torque.) <b>REMARKS</b> • Recommended settings for Pr. 57 during V/F control is 0.5s for 1.5K, 1.0s for 2.2 to 7.5K, and 3.0s for 11K or more. • The setting value does not include resetting time of the inverter.
	9999	Without restart
162	0	With speed search Speed search is made after detection of an instantaneous power failure.
	1	Without speed search Independently of the motor coasting speed, the output voltage is gradually increased with the speed kept as preset, i.e. a reduced voltage starting system.
	10	Speed search is made on startup. The motor starts running at the speed detected by the encoder under vector control.
58	0 to 60s	Normally the motor may be run with the factory settings, but restart or voltage cushion time is adjustable according to the load (moment of inertia, torque) magnitude using Pr. 58, Pr. 163, or Pr. 164.
163	0 to 20s	
164	0 to 100%	Also the output frequency is reduced when the current flow exceeds the Pr. 165 setting.
165	0 to 200%	Invalid for vector control.

- (1) To make automatic restart after instantaneous power failure valid  
Restart function after instantaneous power failure is made valid by setting a value other than "9999" in Pr. 57 "restart coasting time".  
Time set in this Pr. 57 is the control start waiting time from power restoration to automatic restart.
- (2) Selection of whether speed search is used or not (Pr. 162 "automatic restart after instantaneous power failure selection")  
Smooth start at power restoration is available as required only during vector control without encoder and V/F control.

**CAUTION**

1. With speed search (Pr. 162 = "0") under V/F control
  - When the inverter capacity is two rank or more larger than the motor capacity when Pr. 162 = "0" (with speed search), the inverter may not start due to overcurrent (OCT) alarm.
  - Searchable speed is 3000r/min or less.
  - Speed is regarded as 0r/min when the search speed is 150r/min or less.
  - DC injection brake is applied for a moment at speed detection. Therefore speed may decrease if the inertia is small.
2. The restart coasting time in Pr. 57 does not include the speed search time (300ms maximum).  
There is no delay time due to speed search when speed search is not made or vector control is exercised. (excluding the inverter starting time)
3. If two or more motors are connected to one inverter, the inverter functions abnormally. (The inverter does not start smoothly.)
4. When restart operation is selected, UVT and IPF among the alarm output signals are not output at occurrence of an instantaneous power failure.
5. The SU and FU signals are not output during restart but are output after the restart cushion time has elapsed.

**⚠ CAUTION**

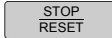
- When automatic restart after instantaneous power failure has been selected, the motor and machine will start suddenly (after the restart coasting time has elapsed) after occurrence of an instantaneous power failure. Stay away from the motor and machine.  
When you have selected automatic restart after instantaneous power failure, apply the supplied CAUTION seals, provided for the Instruction Manual (basic), in easily visible places.
- The motor coasts to a stop as soon as the start signal is turned off or  is pressed during automatic restart cushion time.

**Related parameters**

- Setting of alarm output signal for executing automatic restart after instantaneous power failure ⇒ Pr. 65 "retry selection" (Refer to page 109.)

### 3.9 Additional functions (Pr. 59)

#### 3.9.1 Remote setting function selection (Pr. 59 speed torque)

Even if the control panel is located away from the enclosure, you can use contact signals to perform continuous variable-speed operation, without using analog signals.

Parameter	Name	Factory Setting	Setting Range	Remarks
59	Remote setting function selection	0	0	Remote function not activated.
			1	Remote function activated: Stored into E <sup>2</sup> PROM.
			2	Remote function activated: Not stored into E <sup>2</sup> PROM.
			3	Remote function activated: Not stored into E <sup>2</sup> PROM. (Turn on STF (STR) to clear remote setting)
				Extended mode

##### (1) Pr. 59 = "1" or "2"

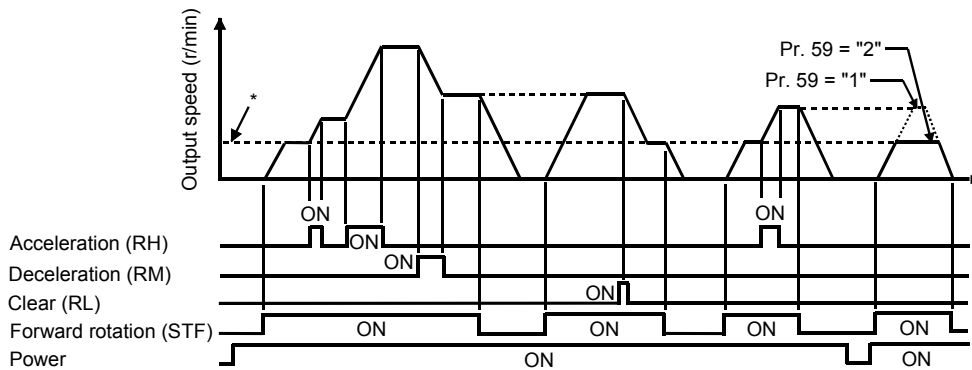

\*External operation speed or PU operation speed other than multi-speed

##### (2) Pr. 59 = "3"

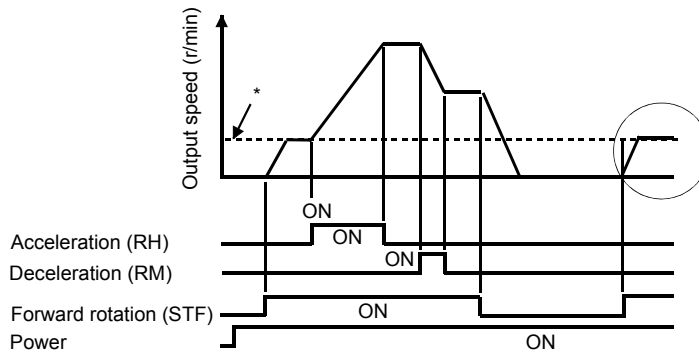

\*External operation speed or PU operation speed other than multi-speed

#### REMARKS

- By merely setting this parameter, you can use the acceleration, deceleration and setting clear functions of the motorized speed setter (FR-FK).
- When the remote function is used, the output speed of the inverter can be compensated for as follows:  
For external operation, speed set by RH/RM operation plus external analog speed command  
For PU operation mode, speed set by RH/RM operation plus DU/PU digital setting speed
- When any value other than 0 is set in Pr. 59, multi-speed operation is invalid. (Refer to page 77.)
- Speed compensation by terminal 1 is made invalid when speed command by terminal 2 is selected.  
Set "1" in Pr. 28 "multi-speed input compensation" to enable speed compensation of terminal 1 (Pr. 28 = "0").



**<Setting>**

Use Pr. 59 to select whether the remote setting function is used or not and whether the speed setting storage function\* in the remote setting mode is used or not. When "1" or "2" is set in Pr. 59, the functions of signals RH, RM and RL are changed to acceleration (RH), deceleration (RM) and clear (RL), respectively. Use Pr. 180 to Pr. 183 and Pr. 187 (input terminal function selection) to set signals RH, RM and RL.

\* Speed setting storage function (Pr. 59 = "1")

This function stores the remotely-set speed (speed set by RH/RM operation) into memory. When power is switched off once, then on, operation is resumed with that output speed value.

**<Speed setting storage conditions>**

- Speed at which the start signal (STF or STR) turns off is stored.
- The remotely-set speed is stored every one minute after one minute has elapsed since turn off (on) of both the RH (acceleration) and RM (deceleration) signals. (The speed is written if the present speed value compared with the past speed value every one minute is different.) (The state of the RL signal dose not affect writing.)

**REMARKS**

This function is invalid under jog operation and PID control operation.

Setting speed is "0"

Even when the remotely-set speed is cleared by turning on the RL (clear) signal after turn off (on) of both the RH and RM signals, the inverter operates at the remotely-set speed stored in the last operation if power is reapplied before one minute has elapsed since turn off (on) of both the RH and RM signals.

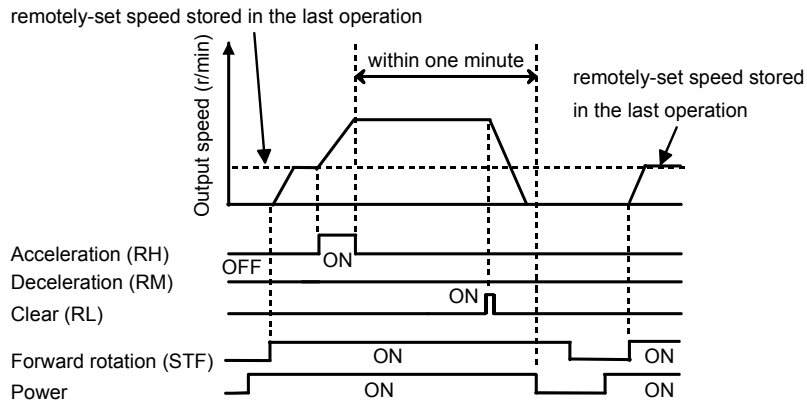

When the remotely-set speed is cleared by turning on the RL (clear) signal after turn off (on) of both the RH and RM signals, the inverter operates at the speed in the remotely-set speed cleared state if power is reapplied after one minute has elapsed since turn off (on) of both the RH and RM signals.

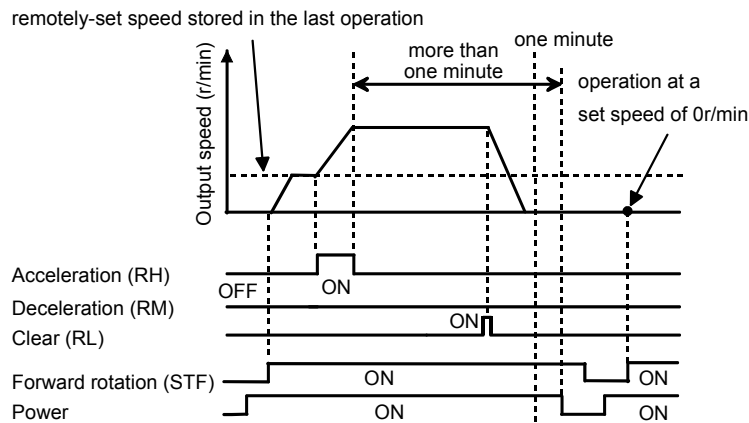

**CAUTION**

- The range of speed changeable by RH (acceleration) and RM (deceleration) is 0 to maximum speed (Pr. 1 setting). Note that the maximum value of set speed is (main speed + maximum speed).

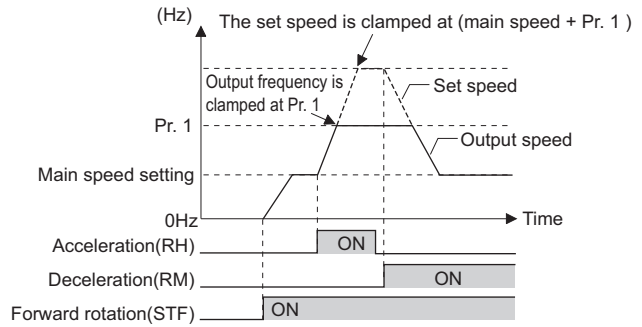

- When the acceleration or deceleration signal turns on, the set speed varies according to the slope set in Pr. 44 "second acceleration/deceleration time" or Pr. 45 "second deceleration time". The output speed acceleration/deceleration times are as set in Pr. 7 "acceleration time" and Pr. 8 "deceleration time", respectively. Therefore, the longer preset times are used to vary the actual output speed. (Refer to page 27 for the set speed and output speed.)
- If the start signal (STF or STR) is off, turning on the RH (acceleration) or RM (deceleration) signal varies the set speed.

**⚠ CAUTION**

⚠ When selecting this function, re-set Pr. 1 "maximum speed" according to the machine.

**Related parameters**

- RH, RM, RL signal terminal assignment ⇒ Pr. 180 to Pr. 183, Pr. 187 (input terminal function selection) (Refer to page 150.)
- Maximum speed setting ⇒ Pr. 1 "maximum speed" (Refer to page 76.)
- Output speed acceleration/deceleration time ⇒ Pr. 7 "acceleration time", Pr. 8 "deceleration time" (Refer to page 78.)
- Time setting for acceleration/deceleration ⇒ Pr. 44 "second acceleration/deceleration time", Pr. 45 "second deceleration time" (Refer to page 78.)
- RH, RM, RL signal compensation ⇒ Pr. 28 "multi-speed input compensation" (Refer to page 88.)

### 3.10 Brake sequence (Pr. 60, Pr. 278 to Pr. 285)

#### 3.10.1 Brake sequence function (Pr. 60, Pr. 278 to Pr. 285 speed )

The inverter automatically sets appropriate parameters for operation.

This function is used to output from the inverter the mechanical brake opening completion signal timing signal in elevator and other applications.

This function prevents the load from dropping with gravity at a start due to the operation timing error of the mechanical brake or an overcurrent alarm from occurring at a stop, ensuring secure operation.

**POINT**

Set "7" or "8" in Pr. 60.

Set any of "0, 2, or 4" in Pr. 800 "control system selection" under external operation and set speed control. (Refer to page 169)

Parameter	Name	Factory Setting	Setting Range	Remarks
60	Intelligent mode selection	0	0, 7, 8	Extended mode
278	Brake opening speed	20r/min	0 to 900r/min	
279	Brake opening current	130%	0 to 200%	
280	Brake opening current detection time	0.3s	0 to 2s	
281	Brake operation time at start	0.3s	0 to 5s	
282	Brake operation speed	25r/min	0 to 900r/min	
283	Brake operation time at stop	0.3s	0 to 5s	
284	Deceleration detection function selection	0	0, 1	
285	Overspeed detection speed	9999	0 to 900r/min, 9999	

**CAUTION**

**When brake sequence mode is selected, automatic restart after instantaneous power failure is invalid.**

#### (1) Wiring example

- Sink logic
- Pr.183=15
- Pr.190=20

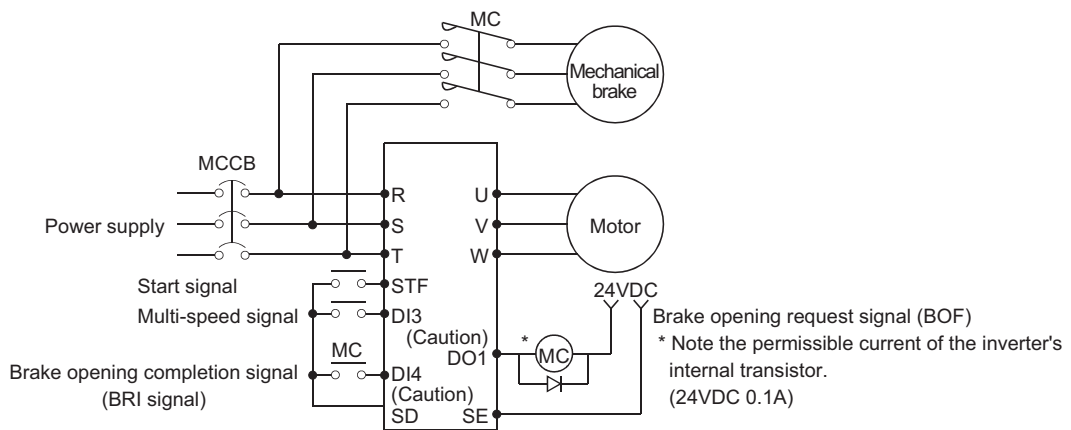

**CAUTION**

**The I/O signal terminal used differs according to the parameter settings. (Refer to page 150, 152.)**

**(2) Operation example**

- At start: When the start signal is input to the inverter, the inverter starts running. When the internal speed command reaches the value set in Pr. 278 and the output current is not less than the value set in Pr. 279, the inverter outputs the brake opening request signal (BOF) after the time set in Pr. 280 has elapsed. When the time set in Pr. 281 has elapsed after the brake opening completion signal (BRI) was input, the inverter increases the internal speed command to the set speed.
- At stop: When the speed has decreased to the speed set in Pr. 282, the brake opening request signal (BOF) is turned off. When the time set in Pr. 283 has elapsed after the brake operation confirmation signal (BRI) was input, the inverter output is switched off.  
 \*If Pr. 60 = "8" (mechanical brake opening completion signal not input), this time is the time after the brake opening request signal is output.

1. Pr. 60 = "7" (brake opening completion signal input)

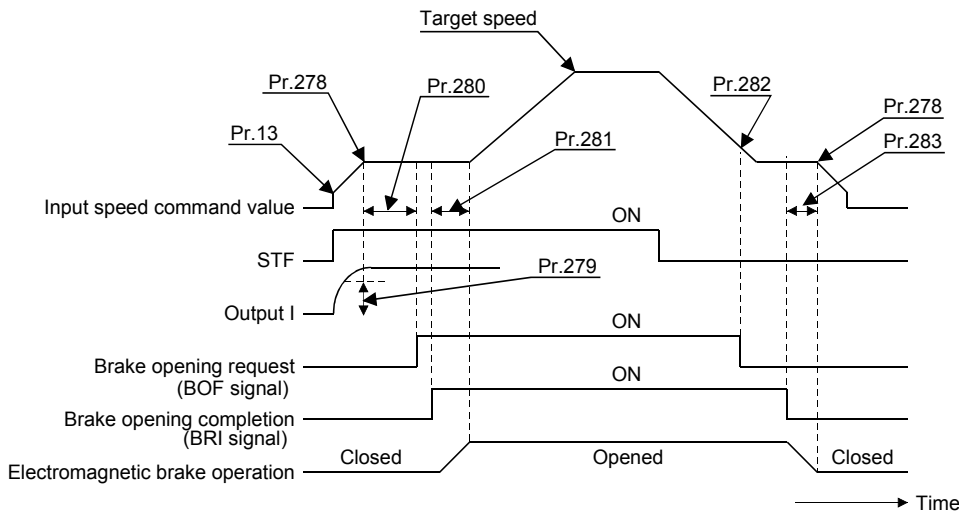

2. Pr. 60 = "8" (mechanical brake opening completion signal not input)

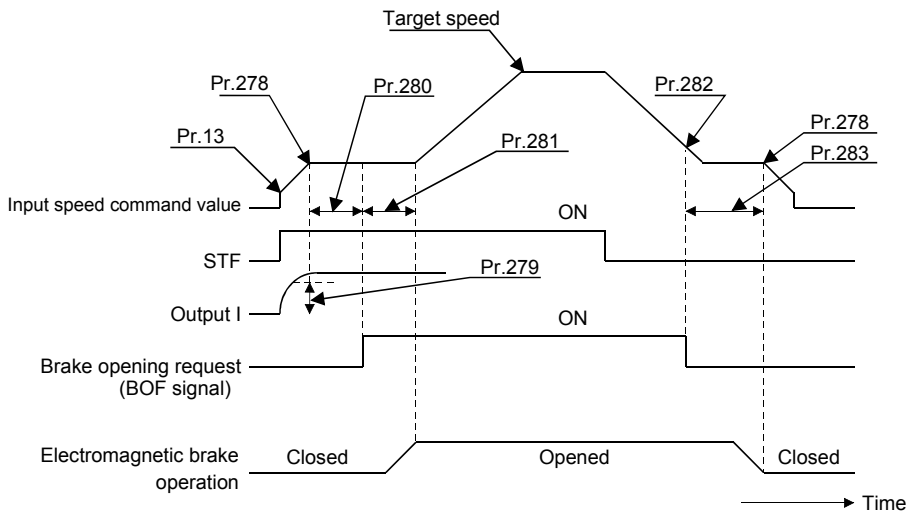

## Brake sequence (Pr. 60, Pr. 278 to Pr. 285)

### (3) Parameter setting

1. Set speed control in Pr.800 "control system selection". (Refer to page 169.)
2. Set "7 or 8" (brake sequence mode) in Pr. 60.

To ensure more complete sequence control, it is recommended to set "7" (brake opening completion signal input) in Pr. 60.

Pr. 60 Setting	Operation Mode	Description	
0	Normal operation mode	—	
7	Brake sequence mode	With mechanical brake opening completion signal input	This function causes the inverter to output the mechanical brake operation timing signal for elevating application. For the function details and setting method, refer to Pr. 278 to Pr. 285 (brake sequence function).
8		Without mechanical brake opening completion signal input	

#### REMARKS

Even if the intelligent operation function has been selected, inputting the jog or RT (second function selection) signal during an inverter stop will switch to the normal operation and give priority to jog operation or second function selection. After intelligent operation has been started, neither the jog signal nor the RT signal is accepted.

3. Refer to the following table and set the parameters.

Parameter	Name	Setting Range	Description
278	Brake opening speed	0 to 900r/min	Set the value higher than the Pr. 13 "starting speed". Setting is enabled only when Pr. 278 ≤ Pr. 282.
279	Brake opening current	0 to 200%	Generally, set this parameter to about 50 to 90%. If the setting is too low, the load is liable to drop due to gravity at start. Suppose that the rated inverter current is 100%.
280	Brake opening current detection time	0 to 2s	Generally, set this parameter to about 0.1 to 0.3s.
281	Brake operation time at start	0 to 5s	Pr. 60 = 7: Set the mechanical delay time until the brake is loosened. Pr. 60 = 8: Set the mechanical delay time until the brake is loosened + about 0.1 to 0.2s.
282	Brake operation speed	0 to 900r/min	Generally, set the Pr. 278 setting + 1 to 2r/min to this parameter. Setting is enabled only when Pr. 282 ≥ Pr. 278.
283	Brake operation time at stop	0 to 5s	Pr. 60 = 7: Set the mechanical delay time until the brake is closed + 0.1s. Pr. 60 = 8: Set the mechanical delay time until the brake is closed + about 0.2 to 0.3s.
284	Deceleration detection function selection	0	Deceleration is not detected.
		1	If deceleration is not normal during deceleration operation, the inverter alarm (E.MB2) is provided to shut off the output and turn off the brake opening request signal (BOF).
285	Overspeed detection speed*	0 to 900r/min	If (detected speed) - (output speed) > Pr. 285, the inverter alarm (E.MB1) is provided to shut off the output and turn off the brake opening request signal (BOF).
		9999	Overspeed is not detected.

\* This function is valid during vector control.

#### CAUTION

**When using this function, set the acceleration/deceleration time to 1s or longer.**

### (4) Setting terminals

The terminals must be assigned using Pr. 180 to Pr. 183 and Pr. 187 and Pr. 190 to Pr. 192 and Pr. 195.

Signal	Brake Sequence Mode	
	Pr. 60 = 7 (with mechanical brake opening completion signal)	Pr. 60 = 8 (without mechanical brake opening completion signal)
BOF	Brake opening request	Brake opening request
BRI	Brake opening completion signal	—

#### CAUTION

1. The brake opening completion signal (BRI) is a parameter valid when Pr. 60 = 7.
2. Changing the terminal function using any of Pr. 180 to Pr. 183, Pr. 187, Pr. 190 to Pr. 192, and Pr. 195 may affect the other functions. Confirm the functions of the corresponding terminals before making setting. (Refer to page 150.)

### (5) Protective functions

If any of the following errors occurs in the brake sequence mode, the inverter results in an alarm, shuts off the output, and turns off the brake opening request signal (BOF terminal).

On the control panel (FR-DU04-1) LED or parameter unit (FR-PU04V) screen, the following errors are displayed:

Error Display	Description
E.MB1	(Detected speed) - (output speed) > Pr. 285 during vector control. (Overspeed detection function)
E.MB2	Deceleration is not normal during deceleration operation (Use Pr. 284 to select this function.) (Except stall prevention operation)
E.MB3	Brake opening request signal (BOF) turned on though the motor is at a stop. (Gravity drop prevention function)
E.MB4	More than 2s after the run command (forward or reverse rotation) is input, the brake opening request signal (BOF) does not turn on.
E.MB5	Although more than 2s have elapsed after the brake opening request signal (BOF) turned on, the brake opening completion signal (BRI) does not turn on.
E.MB6	Though the inverter had turned on the brake opening request signal (BOF), the brake opening completion signal (BRI) turned off midway.
E.MB7	Although more than 2s have elapsed after the brake opening request signal (BOF) turned off at a stop, the brake opening completion signal (BRI) does not turn off.

## 3.11 Operation selection function 2 (Pr. 65 to Pr. 79)

### 3.11.1 Retry function (Pr. 65, Pr. 67 to Pr. 69 speed torque )

When the inverter output is stopped by the protective function (major fault), this function causes the inverter to automatically reset itself to make a retry. You can select whether retry operation is to be performed or not, alarms reset for retry, number of retries made, and waiting time.

Parameter	Name	Factory Setting	Setting Range	Remarks
65	Retry selection	0	0 to 5	Extended mode
67	Number of retries at alarm occurrence	0	0, 1 to 10, 101 to 110	
68	Retry waiting time	1s	0 to 10s	
69	Retry count display erasure	0	0	

#### <Setting>

- Use Pr. 65 to select the protective functions (major faults) to be activated for retries.

Errors Reset for Retry		Pr. 65						Remarks
Error definition	Abbreviation	0	1	2	3	4	5	
Acceleration overcurrent	E.OC1	●	●		●	●	●	
Constant-speed overcurrent	E.OC2	●	●		●	●		
Deceleration overcurrent	E.OC3	●	●		●	●	●	
Acceleration overvoltage	E.OV1	●		●	●	●		
Constant-speed overvoltage	E.OV2	●		●	●	●		
Deceleration overvoltage	E.OV3	●		●	●	●		
Motor thermal relay	E.THM	●						
Transistor thermal relay	E.THT	●						
Instantaneous power failure	E.IPF	●				●		
Undervoltage	E.UVT	●				●		
Brake transistor	E.BE	●				●		
Earth (Ground) fault protection	E.GF	●				●		
Output phase failure	E.LF							
External thermal relay	E.OHT	●						
Stall prevention-triggered stop	E.OLT	●				●		
Option alarm	E.OPT	●				●		
Option 1 alarm	E.OP1	●				●		

## Operation selection function 2 (Pr. 65 to Pr. 79)

Errors Reset for Retry		Pr. 65						Remarks
Error definition	Abbreviation	0	1	2	3	4	5	
Option 2 alarm	E.OP2	●				●		
Option 3 alarm	E.OP3	●				●		
Storage device alarm	E.PE	●				●		
PU disconnection	E.PUE							
Retry count excess	E.RET							
CPU error	E.CPU							
Fan stop	E.FAN							
Fin overheat	E.FIN							
Overspeed occurrence	E.OS	●				●		Under vector control
Speed deviation large	E.OSD	●				●		Under vector control
Encoder no-signal	E.ECT							Under vector control
Position error large	E.OD							Under vector control
Encoder A no-signal	E.ECA							Under vector control
MB1	E.MB1	●				●		Brake sequence
MB2	E.MB2	●				●		Brake sequence
MB3	E.MB3	●				●		Brake sequence
MB4	E.MB4	●				●		Brake sequence
MB5	E.MB5	●				●		Brake sequence
MB6	E.MB6	●				●		Brake sequence
MB7	E.MB7	●				●		Brake sequence
P24 short circuit	E.P24							
P12 short circuit	E.P12							
Circuit alarm (P5S short circuit)	E.CTE							

\* ● indicates the errors selected for retry.

- Use Pr. 67 to set the number of retries at alarm occurrence.

Pr. 67 Setting	Number of Retries	Alarm Signal Output
0	Retry is not made.	—
1 to 10	1 to 10 times	Not output every time.*
101 to 110	1 to 10 times	Output every time.

\* If the number of retries to be made is exceeded, "E<sub>r</sub>E<sub>r</sub>" (retry count excess) is displayed.

- Use Pr. 68 to set the waiting time from when an inverter alarm occurs until a retry is made in the range 0 to 10s.
- Reading the Pr. 69 value provides the cumulative number of successful restarts made by retries. Writing "0" erases the cumulative number of times.

### CAUTION

- The cumulative number in Pr. 69 is incremented by "1" when retry operation is regarded as successful, i.e. when normal operation is continued without the protective function (major fault) being activated during a period four times longer than the time set in Pr. 68.
- If the protective function (major fault) is activated consecutively within a period four times longer than the above waiting time, the control panel may show data different from the latest data or the parameter unit (FR-PU04V) may show data different from the first retry data. The data stored as the error reset for retry is only that of the protective function (major fault) activated the first time.
- When an inverter alarm is reset by the retry function at the retry time, the accumulated data of the electronic thermal relay function, etc. are not cleared. (Different from the power-on reset.)

## ⚠ CAUTION

⚠ When you have selected the retry function, stay away from the motor and machine unless required. They will start suddenly (after the predetermined time has elapsed) after occurrence of an alarm. When you have selected the retry function, apply the CAUTION seals provided for the Instruction Manual (basic) in easily visible places.

Pr. 70 ➡ Refer to Pr. 30 (page 92)

### 3.11.2 Applied motor (Pr. 71, Pr. 450 speed torque position )

Set the motor used.

When using an other manufacturer's motor, set "3" or "13" in Pr.71 and perform offline auto tuning. Refer to the Instruction Manual (basic) for the motor setting, etc.

Parameter	Name	Factory Setting	Setting Range	Remarks
71	Applied motor	30	0, 3 to 8, 10, 13 to 18, 20, 23, 24, 30, 33, 34	
450	Second applied motor	9999	0, 10, 30, 9999	9999: Second applied motor invalid

#### <Setting>

- Refer to the following table and set this parameter according to the motor used.

Setting	Motor	Control Constants
0	Mitsubishi standard motor (SF-JR)	Inverter internal constants
3	Other manufacturer's standard motor	Offline auto tuning
4		Offline auto tuning data utilization
5		Star connection direct input
6		Delta connection direct input
7		Star connection direct input + offline auto tuning
8		Delta connection direct input + offline auto tuning
10	Mitsubishi constant-torque motor (SF-HRCA)	Inverter internal constants
13	Other manufacturer's constant-torque motor	Offline auto tuning
14		Offline auto tuning data utilization
15		Star connection direct input
16		Delta connection direct input
17		Star connection direct input + offline auto tuning
18		Delta connection direct input + offline auto tuning
20	SF-JR (4P)-1.5kW or less (during vector control)	Inverter internal constants
23		Offline auto tuning
24		Offline auto tuning data utilization
30 (factory setting)	SF-V5RU dedicated motor (including SF-VR type motor)	Inverter internal constants
33		Offline auto tuning
34		Offline auto tuning data utilization

#### CAUTION

- Refer to page 120 for offline auto tuning.
- Refer to page 39 for details of setting conventional Mitsubishi motors and other manufacturer's motors.

## ⚠ CAUTION

⚠ Set this parameter correctly according to the motor used.

#### REMARKS

- For online auto tuning, refer to the Instruction Manual (basic).



3.11.3 PWM carrier frequency selection (Pr. 72, Pr. 240 **speed** **torque** **position**)

By parameter setting, you can set whether to exercise the Soft-PWM control that changes the motor tone or select with or without long wiring mode.

- Soft-PWM control is a control method that changes the motor noise from a metallic tone into an unoffending complex tone.
- Surge voltage is suppressed regardless of wiring length in the long wiring mode. (When operating the 400V motor with wiring length of 40m or longer, select long wiring mode.)

Parameter	Name	Factory Setting	Setting Range	Remarks
72	PWM frequency selection	1	1 to 6	Simple mode
240	Soft-PWM setting	10	0, 1, 10, 11	Extended mode

<Setting>

Pr. 72 Setting	Description
1	2.25kHz
2	4.5kHz
3	6.75kHz
4	9kHz
5	11.25kHz
6	13.5kHz

**CAUTION**

1. An increased PWM carrier frequency will decrease the motor sound but increase noise and leakage currents. Therefore, perform the reduction techniques. (Refer to page 12.)
2. Since Pr. 240 is factory-set to "10", PWM carrier frequency is 2.25 kHz constant even if "2" or larger value is set in Pr. 72. Set "0 or 1" in Pr. 240 to decrease the motor noise.

Pr. 240 Setting	Description		Remarks
	Soft-PWM	long wiring mode	
0	Invalid	Invalid	_____
1	Valid (when Pr. 72 = "1 or 2")	Invalid	
10	Invalid	Valid	Carrier frequency is 2.25kHz. (The Pr.72 "PWM frequency selection" setting is made invalid.)
11	Valid	Valid	

**CAUTION**

1. When long wiring mode is made valid, torque reduces about 5% in the constant power range.
2. The output voltage at rated frequency decreases by about 1.5V maximum (200V class)/about 3.0V maximum (400V class) during V/F control.
3. Use an insulation-enhanced motor for the 400V class. Refer to page 22 for inverter driving of the 400V class motor.

**3.11.4 Speed setting signal on/off selection (Pr. 73 speed torque )**

You can select the override function to make main speed setting with the speed setting auxiliary terminal 1. Using Pr. 73, set the input specifications of terminals 1 and 2 and whether to use the override function or not.

**POINT**

- Set "0" in Pr. 807 "speed limit selection". (Refer to page 173.)
- Set "0" in Pr. 868 "terminal 1 function selection". (Refer to page 183.)
- Refer to Pr. 902 "speed setting terminal 2 bias", Pr. 903 "speed setting terminal 2 gain" for calibration. (Refer to page 190.)

Parameter	Name	Factory Setting	Setting Range	Remarks
73	Speed setting signal	0	0	Extended mode
			4	
			10	
			14	

Pr. 73 Setting	Control Mode	Function		Terminal 1 (0 to ±10V)	Terminal 2 (0 to 10V) <sup>*3</sup>
		Override	Polarity reversible		
0	Speed control	×	×	Addition auxiliary <sup>*1</sup> Speed command	Main speed setting
4		○ <sup>*2</sup>	×	Main speed setting	Override signal
10		×	○	Addition auxiliary <sup>*1</sup> Speed command	Main speed setting
14		○ <sup>*2</sup>	○	Main speed setting	Override signal
0	Torque control	×	×	Addition auxiliary Speed limit	Speed limit
4		○ <sup>*4</sup>	×	Speed limit	Override signal
10		×	×	Addition auxiliary Speed limit	Speed limit
14		○ <sup>*4</sup>	×	Speed limit	Override signal
0, 4, 10, 14	Position control	No function		No function	No function

\*1: The value of terminal 1 (speed setting auxiliary input) is added to the main speed setting signal of terminal 2.

\*2: When override has been selected, terminal 1 is for the main speed setting and terminal 2 for the override signal (50 to 150% at 0 to 10V). (Refer to page 156 for bias/gain adjustment.)

\*3: When "30" or "31" is set in Pr. 128, terminal 2 acts as the PID set point function.

\*4: When override has been selected, terminal 1 is for speed limit and terminal 2 is for the override signal.

**CAUTION**

To change the maximum output speed at the input of the maximum speed command voltage, use the speed setting voltage gain, Pr. 903 (Pr. 905).

At this time, the command voltage need not be input.

Also, the acceleration/deceleration time, which is a slope up/down to the acceleration/deceleration reference speed, is not affected by the change in Pr. 73 setting.

## Operation selection function 2 (Pr. 65 to Pr. 79)

- (a) When Pr. 73 "speed setting signal" value is "0"  
The voltage across terminals 1-5 is added to the voltage signal (positive) across terminals 2-5. If the result of addition is negative, it is regarded as 0 and the motor comes to a stop.
- (b) When Pr. 73 "speed setting signal" value is "10"  
The polarity reversible operation function is selected.  
The voltage signal across terminals 1-5 is added to the voltage signal (positive) across terminals 2-5. A positive addition result turns the motor in the forward rotation direction (when the STF terminal turns on), or a negative result turns it in the reverse rotation direction (when the STF terminal turns on). The compensation signal of terminal 1 can also be added to the multi-speed setting.

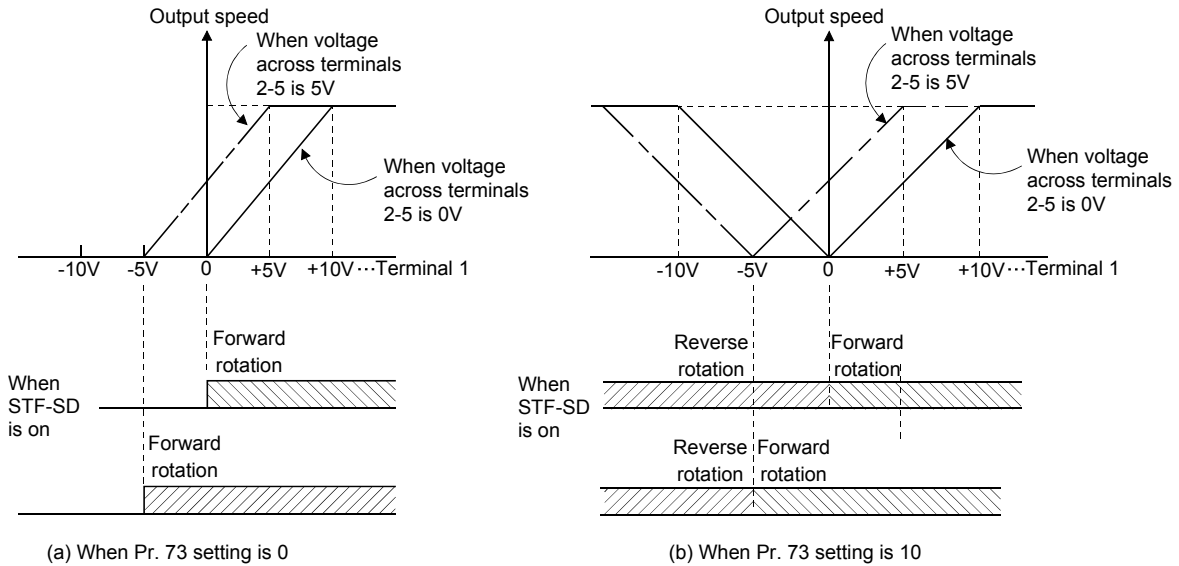

### Auxiliary Input Characteristics

- 1) Multi-speed input compensation  
By setting 1 in Pr. 28 "multi-speed input compensation selection" (factory setting 0), the speed from the auxiliary input terminal 1 is added when multi-speed operation is performed. (Refer to page 77.)

#### Inverter Output According to Start Signal and Auxiliary Input Terminal Polarity

Pr. 73 Setting	Added Command Voltage	Start Signal Input	
		STF-SD	STR-SD
0	+	Forward rotation	Reverse rotation
	-	Stop	Stop
10	+	Forward rotation	Reverse rotation
	-	Reverse rotation	Forward rotation

- 2) Override  
For the above compensation input, the fixed compensation amount is applied to each speed. Using the override function easily varies each speed equally.  
By setting either "4 or 14" in Pr. 73, override allows the parameter-set multiple speeds and analog input across terminals 1-5 to be varied equally within the range 50% to 150% (The range can be increased with Pr. 252 and Pr. 253) by the analog signal input across terminals 2-5.

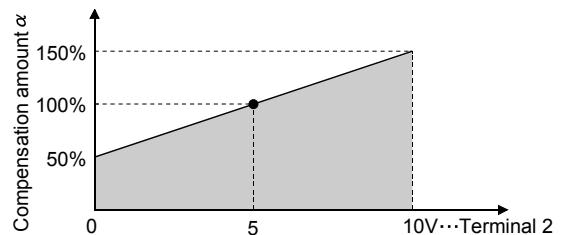

Override Setting Signal vs. Compensation Amount

How to find each speed (N)

$$N = N_{pr.} \times \frac{\alpha}{100} \text{ [r/min]}$$

$N_{pr.}$ : Speed setting [r/min]

[Multiple speeds  
Analog input across terminals 1-5]

$\alpha$ : Override compensation amount [%]  
(Analog input across terminals 2-5)

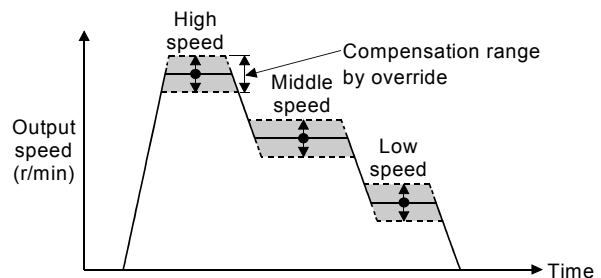

Multi-speed Override Operation

### 3.11.5 Reset selection/disconnected PU detection/PU stop selection



(Pr. 75 speed torque position )

You can select the reset input acceptance, PU (FR-DU04-1/FR-PU04V) connector disconnection detection function and PU stop function.

- Reset selection: You can select the reset function input (RES signal) timing.
- Disconnected PU detection: When the disconnection of the PU (FR-DU04-1/FR-PU04V) from the inverter for more than 1s is detected, the inverter outputs an alarm code (E.PUE) and comes to an alarm stop.  
The motor decelerates to a stop when the PU is disconnected during PU jog operation with Pr. 75 set to any of "0, 1, 14, 15"(operation is continued if the PU is disconnected).
- PU stop selection: When an alarm etc. occurs in any operation mode, you can stop the motor from the control panel by pressing .

Parameter	Name	Factory Setting	Setting Range	Remarks
75	Reset selection/disconnected PU detection/PU stop selection	14	0 to 3, 14 to 17	Extended mode

#### <Setting>

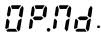

Pr. 75 Setting	Reset Selection	Disconnected PU Detection	PU Stop Selection
0	Reset input is always enabled.	If the PU is disconnected, operation will be continued as-is.	The PU stop key is invalid. 
1	Reset input is enabled only when the protective function is activated.		
2	Reset input is always enabled.	When the PU is disconnected, the inverter output is shut off.	The PU stop key is valid only in the PU or combined operation mode (Pr. 79 = "4").
3	Reset input is enabled only when the protective function is activated.		
14	Reset input is always enabled.	If the PU is disconnected, operation will be continued as-is.	 input decelerates the motor to a stop in any of the PU, external and communication operation modes.
15	Reset input is enabled only when the protective function is activated.		
16	Reset input is always enabled.	When the PU is disconnected, the inverter output is shut off.	
17	Reset input is enabled only when the protective function is activated.		

#### (1) Restarting method when stop was made by inputting from the control panel (Method of restarting from indication)

- 1)After the motor has decelerated to a stop, turn off the STF or STR signal.
- 2)Press  twice\* to display .



#### CAUTION

When Pr. 79 = "3", press  three times to display . Then press  and proceed to 3).

(\*For monitor screen).....  Refer to the Instruction Manual (basic) for details of the monitor display provided by pressing .

- 3)Press .
- 4)Turn on the STF or STR signal.

#### REMARKS

- If the reset signal (RES) is provided during operation, the inverter shuts off its output while it is reset, the internal thermal integrated value of the electronic thermal relay function and the number of retries are reset, and the motor coasts.
- The Pr. 75 value can be set any time. This value does not return to the initial value even if parameter (all) clear is executed.
- When the motor is stopped from the PU,  and  are displayed alternately. An alarm output is not provided.

(2) Restarting method when stop was made by inputting **STOP/RESET** from PU

- 1) After the motor has decelerated to a stop, turn off the STF or STR signal.
- 2) Press **EXT**.
- ..... (Recovery from **PS**)
- 3) Turn on the STF or STR signal.

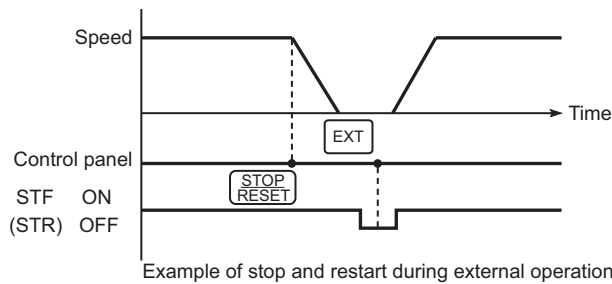

Alternatively, you can make a restart by making a power-on reset or resetting the inverter using the reset terminal of the inverter.

**REMARKS**

- If the reset signal (RES) is provided during operation, the inverter shuts off its output while it is reset, the internal thermal integrated value of the electronic thermal relay function and the number of retries are reset, and the motor coasts.
- To make a restart, confirm that the PU is connected and then reset the inverter.
- The Pr. 75 value can be set any time. This value does not return to the initial value even if parameter (all) clear is executed.
- When the motor is stopped from the PU, PS is displayed. An alarm output is not provided.
- Pr. 250 is made invalid.

**⚠ CAUTION**

**⚠ Do not reset the inverter with the start signal input. Doing so will start the inverter immediately after it has recovered from the error, causing hazard.**

**3.11.6 Parameter write disable selection (Pr. 77 **speed torque position**)**

You can select between enable and disable for parameter write. This function is used to prevent parameter values from being rewritten by misoperation.

Parameter	Name	Factory Setting	Setting Range	Remarks
77	Parameter write disable selection	0	0, 1, 2	Simple mode

**<Setting>**

Pr. 77 Setting	Function
0	Write is enabled only during a stop in the PU operation mode.*
1	Parameter write is disabled.
2	Write is enabled even during operation. Write is enabled independently of the operation mode.

**CAUTION**

- \* The shaded parameters in the parameter list (refer to page 66) can always be written, regardless of the operation mode and operation status.
- Even when "2" is set in Pr. 77, the following parameters do not allow writing during operation. Pr. 60, Pr. 71, Pr. 72, Pr. 79, Pr. 80 to Pr. 84, Pr. 90 to Pr. 96, Pr. 180 to Pr. 183, Pr. 187, Pr. 190 to Pr. 192, Pr. 195, Pr. 450, Pr. 451, Pr. 453, Pr. 454, Pr. 800, Pr. 819, Pr. 851, Pr. 852, Pr. 859 and Pr. 868 Stop operation when changing the values of the above parameters.
- By setting "1" in Pr. 77, the following clear operations can be inhibited:
  - Parameter clear
  - All parameter clear
 Even when "1" is set in Pr. 77, write is allowed for Pr. 22, Pr. 75, Pr. 77 and Pr. 79.

**3.11.7 Reverse rotation prevention selection (Pr. 78 speed torque position )**

This function can prevent any reverse rotation fault resulting from the mis-input of the start signal.

**POINT**

Used for a machine that runs only in one direction, e.g. fan, pump.  
(The setting of this parameter is valid for combined operation, PU operation, external operation and communication operation.)

Parameter	Name	Factory Setting	Setting Range	Remarks
78	Reverse rotation prevention selection	0	0, 1, 2	Extended mode

**<Setting>**

Control Method	Pr. 78 Setting	Start Signal		Limit on Analog Reversible
		STF	STR	
Speed control V/F control	0	Valid	Valid	Negative input starts rotation in the direction opposite to that of start signal
	1 (reverse rotation lock)	Valid	Invalid	Negative input does not start rotation.
	2 (forward rotation lock)	Invalid	Valid	
Torque control	0	Valid	Valid	Negative input starts rotation in the direction opposite to that of start signal
	1 (reverse rotation lock)	Valid	Invalid	Negative analog input results as follows.
	2 (forward rotation lock)	Invalid	Valid	
Position control	0	Functions as a stroke signal and motor does not rotate in the direction where the STF or STR signal does not exist.		Under position control, analog command is irrelevant to the forward/reverse rotation lock function as it does not function in other than torque limit setting (absolute value used for operation).
	1 (reverse rotation lock)	Motor does not rotate in the reverse rotation direction.		
	2 (forward rotation lock)	Motor does not rotate in the forward rotation direction.		

**3.11.8 Operation mode selection (Pr. 79 speed torque position )**

Used to select the operation mode of the inverter.

The inverter can be run from the control panel or parameter unit (PU operation), with external signals (external operation), or by combination of PU operation and external operation (external/PU combined operation).

The external operation mode is selected at power on (factory setting).

Parameter	Name	Factory Setting	Setting Range
79	Operation mode selection	0	0 to 4, 6 to 8

## Operation selection function 2 (Pr. 65 to Pr. 79)

### <Setting>

In the following table, operation from the control panel or parameter unit is abbreviated to PU operation.

Pr. 79 Setting	Function		
0	At power on, the external operation mode is selected. You can change between the PU operation mode and external operation mode from the control panel (MODE) or parameter unit (PU / EXT). Refer to the fields of settings 1 and 2 for the corresponding modes.		
1	Operation mode	Speed command	Start signal
	PU operation mode	Setting from the control panel or FR-PU04V	FWD , REV
2	External operation mode	External signal input (across terminals 2(1)-5, multi-speed selection, jog)	External signal input (terminal STF, STR)
3	External/PU combined operation mode 1	Digital setting by PU key operation or external signal input (multi-speed setting)	External signal input (terminal STF, STR)
4	External/PU combined operation mode 2	External signal input (across terminals 2(1)-5, multi-speed selection, jog)	FWD , REV
6	Switchover mode Switchover between PU operation, external operation and computer link operation (when a communication option is used) can be done while running.		
7	External operation mode (PU operation interlock) X12 signal ON..... Can be switched to PU operation mode (output stop during external operation) X12 signal OFF .... Switching to PU operation mode inhibited		
	Operation mode switchover using external signal (disallowed during operation) X16 signal ON..... Switched to external operation mode X16 signal OFF .... Switched to PU operation mode		

### REMARKS

- A stop function (PU stop selection) by  of the PU (FR-DU04-1/FR-PU04V) is made valid during the operation other than the PU operation mode. (Refer to page 115)
- Either "3" or "4" may be set to select the PU/external combined operation, and these settings differ in starting method. Refer to page 128 for the computer link operation mode.

### (1) Switchover mode

PU operation, external operation and computer link operation (when used with the communication option) can be used by switching between them.

Operation Mode Switching	Switching Operation/Operating Status
External operation to PU operation	1) Change the operation mode to the PU operation mode from the control panel or parameter unit. • Rotation direction is the same as that of external operation. • Set speed is as set by the potentiometer (speed setting potentiometer). (Note that the setting will disappear when power is switched off or the inverter is reset.)
External operation to computer link operation	1) Mode change command to computer link mode is transmitted from the computer. • Rotation direction is the same as that of external operation. • Set speed is as set by the potentiometer (speed setting potentiometer). (Note that the setting will disappear when power is switched off or the inverter is reset.)
PU operation to external operation	1) Press the external operation key of the parameter unit. • Rotation direction is determined by the external operation input signal. • Set speed is determined by the external speed setting signal.
PU operation to computer link operation	1) Mode change command to computer link mode is transmitted from the computer. • Rotation direction and set speed are the same as those of PU operation.
Computer link operation to external operation	1) Command to change to external mode is transmitted from the computer. • Rotation direction is determined by the external operation input signal. • Set speed is determined by the external speed setting signal.
Computer link operation to PU operation	1) Select the PU operation mode with the control panel or parameter unit. • Rotation direction and set speed are the same as those of computer link operation.

**(2) PU operation interlock**

The PU operation interlock function is designed to forcibly change the operation mode to external operation mode when the X12 signal input turns off. This function prevents the inverter from being inoperative by the external command if the mode is accidentally left unswitched from PU operation mode.

1) Preparation

- Set "7" (PU operation interlock) in Pr. 79.
- Using any of Pr. 180 to Pr. 183 and Pr. 187 (input terminal function selection), allocate the terminal used to input the X12 signal. (Refer to page 150)

**REMARKS**

Changing the terminal assignment using Pr. 180 to Pr. 183, Pr. 187 (input terminal function selection) may affect the other functions. Check the functions of the corresponding terminals before making setting.

2) Function

X12 Signal	Function/Operation
ON	Output stop during external operation. Operation mode can be switched to the PU operation mode. PU operation allowed.
OFF	Forcibly switched to the external operation mode. External operation allowed. Switching to the PU operation mode inhibited.

**<Function/operation changed by switching on-off the X12 signal>**

Operating Condition		X12 Signal	Operation Mode	Operating Status
Operation mode	Status			
PU	During stop	ON→OFF (*)	PU → External	During stop
	During operation	ON→OFF (*)		If external operation speed setting and start signal are entered, operation is performed in that status.
External	During stop	OFF→ON	External	During stop
		ON→OFF		
	During operation	OFF→ON		During operation → output stop
		ON→OFF		Output stop → operation

**REMARKS**

- If the X12 signal is on, the operation mode cannot be switched to the PU operation mode when the start signal (STF, STR) is on.
- \* The operation mode switches to the external operation mode independently of whether the start signal (STF, STR) is on or off. Therefore, the motor is run in the external operation mode when the X12 signal is turned off with either of STF and STR on.
- When the X12 signal is off during external operation mode, the operation mode cannot be changed to the PU operation mode. (Change to the PU operation mode after switching the X12 signal on)

**(3) Operation mode external signal switching function**

1) Preparation

- Set "8" (operation mode switchover using the external signal with signal) in Pr. 79.
- Using any of Pr. 180 to Pr. 183 and Pr. 187 (input terminal function selection), allocate the terminal used to input the X16 signal.

**REMARKS**

Changing the terminal assignment using Pr. 180 to Pr. 183, Pr. 187 (input terminal function selection) may affect the other functions. Check the functions of the corresponding terminals before making setting. Refer to page 150 for details.

2) Function

This switching is enabled only during an inverter stop and cannot be achieved during operation.

X16 Signal	Operation Mode
ON	External operation mode (cannot be changed to PU operation mode)
OFF	PU operation mode (cannot be changed to external operation mode)

**Related parameters**

Pr. 75 "PU stop selection" (Refer to page 115.)



## 3.12 Offline auto tuning (Pr. 80 to Pr. 96)

### 3.12.1 Offline auto tuning function

(Pr. 9, Pr. 80, Pr. 81, Pr. 83, Pr. 84, Pr. 71, Pr. 96, Pr. 450, Pr. 452 speed torque)

If any other manufacturer's motor is used, using the offline auto tuning function runs the motor with the optimum operating characteristics.

- By performing offline auto tuning, the inverter measures the necessary motor constants.
- Offline auto tuning can be performed with an inertia load, e.g. coupling, connected. (As the load is lighter, tuning accuracy is higher. Tuning accuracy does not change even if the inertia is large.)
- For the offline auto tuning, you can select either the motor non-rotation mode or rotation mode. The rotation mode has higher tuning accuracy than the non-rotation mode. The rotation mode should be selected for the online auto tuning.
- If any other manufacturer's motor is used, perform offline auto tuning (Pr. 96 = "101") with motor alone to run the motor before performing online auto tuning. (The motor with inertia load can be connected.)
- Note that it is necessary to perform offline auto tuning (non-rotation mode (Pr. 96 = "1")) in order for the wiring length resistance to be reflected on the control when the wiring length of the Mitsubishi motor used (SF-V5RU, SF-JR, SF-HRCA) is long (30m or longer as a reference).

(For online auto tuning, refer to the Instruction Manual (basic). For other settings, refer to page 39)

#### CAUTION

1. The motor capacity is equal to or one rank lower than the inverter capacity.
2. Special motors such as high-slip motor and high-speed motor cannot be tuned.
3. Motor runs at up to about the rated speed of the motor.
4. Make sure that the motor is connected. (At a tuning start, the motor should be at a stop.)
5. Tune the motor alone without connecting a load (e.g. frictional stationary load) to the motor. (An inertia load such as a coupling may remain connected.)
6. Use the encoder that is coupled directly to the motor shaft without looseness.
7. Offline auto tuning will not be performed properly if it is performed with a reactor or surge voltage suppression filter (FR-ASF-H) connected between the inverter and motor. Remove it before starting tuning.

#### REMARKS

- When using the Mitsubishi vector dedicated motor (SF-V5RU, SF-VR), Mitsubishi standard motor (SF-JR with encoder), or Mitsubishi constant-torque motor (SF-HRCA with encoder), offline auto tuning is not necessary.
- You can copy the tuning data (motor constants) to another inverter with the PU (FR-DU04-1/FR-PU04V).
- The offline auto tuning status can be monitored with the PU (FR-DU04-1/FR-PU04V).

### 3.12.2 Parameters

Set the following parameters.

Parameter	Name	Setting Range	Factory Setting	Remarks
71	Applied motor	Refer to page 111 and set "3 (standard motor)", "13 (constant-torque motor)" or "33 (SF-V5RU or SF-VR)". Electronic thermal characteristics are also changed in accordance with the motor.		
9	Electronic thermal O/L relay	0 to 500A (Set 0 for use of an external thermal relay.)	0A	Refer to the motor rating plate and set the rated value. (If two or more rated values are given in the motor rating plate, set the values for 200V/60Hz(400V/60Hz)
80	Motor capacity	0.4 to 55kW	Inverter capacity	
81	Number of motor poles	2, 4, 6	4	
83	Rated motor voltage	0 to 1000V	200V/400V	
84	Rated motor frequency	10 to 200Hz	60Hz	
96	Auto tuning setting/status	0, 1, 101	0	0 : Auto tuning not performed 1 : Tuning performed without motor running 101: Tuning performed with motor running
851	Number of encoder pulses	0 to 4096	2048	
852	Encoder rotation direction	0,1	1	
876	Thermal relay protector input	0,1	1	

### 3.12.3 Execution of offline auto tuning

The following applies to the first motor.

---

#### CAUTION

---

- Note the following when "101" (offline auto tuning performed with motor running) is set in Pr. 96.
    - Ensure safety when the motor starts running.
    - Torque is not enough during tuning.
    - The motor may be run at nearly its rated frequency (Pr. 84 setting) without any problem.
    - The brake is open.
    - When over current alarm (E.OC1, OC2, OC3) occurs, set acceleration time longer using Pr. 7.
    - No external force is applied to rotate the motor.
      - If "1" (tuning performed without motor running) is set in Pr. 96, the motor may run slightly (However, torque is not enough). Therefore, fix the motor securely with a mechanical brake, or before tuning, make sure that there will be no problem in safety if the motor runs.
      - \*This instruction must be followed especially in vertical lift applications.
      - Note that if the motor runs slightly, tuning performance is unaffected.
  - During offline auto tuning, only the following I/O signals are valid:
    - Input signals (STOP, OH, MRS, RT, RES, STF, STR)
    - Output signals (RUN, OL, IPF, DA1, DA2, A, B, C)
    - Take extra precaution when designing a sequence where a mechanical brake is opened by the RUN signal.
- 

#### (1) Parameter setting

- Select Pr. 851 "number of encoder pulses" and Pr. 852 "encoder rotation direction" (Refer to the Instruction Manual (basic).)
- Select Pr. 80 "motor capacity" and Pr. 81 "number of motor poles".
- Refer to the parameter details to set the parameters below.
  - 1) Set "1" or "101" in Pr. 96
    - When the setting is "1" . . . . .tuning performed without motor running
    - When the setting is "101" . . . . .tuning performed with motor running
  - 2) Set Pr. 9 "electronic thermal O/L relay".
    - When using the external thermal, change the Pr. 9 setting back to "0" after offline auto tuning. The electronic thermal function is made invalid. Set "0" in Pr. 876 if the external thermal relay is not used.
  - 3) Set the rated motor voltage (V) in Pr. 83.
  - 4) Set the rated motor frequency (Hz) in Pr. 84.
  - 5) Select the motor in Pr. 71.
    - Example
    - Mitsubishi standard motor . . . . . Pr. 71 = "3"
    - Mitsubishi constant torque motor . . . . . Pr. 71 = "13"
    - Mitsubishi standard motor SF-JR 4 poles (1.5kW or less) . . . . . Pr. 71 = "23"
    - SF-V5RU, SF-VR . . . . . Pr. 71 = "33"

---

#### CAUTION

---

For the setting value, set the motor rating plate value. When using a motor having several rated values, e.g. a standard motor, set a value for 200V/60Hz or 400V/60Hz.

---

#### (2) Tuning command

After setting the above parameters, press  or .  
 (For external operation, turn on the run command (STF, STR).)

#### REMARKS

- To force tuning to end, use the MRS or RES signal or press . (The start signal may also be turned off to end.)
- Excitation noise is produced during tuning.
- When executing offline auto tuning, input the run command after switching on the main circuit power (R, S, T) of the inverter.

### (3) Monitoring during execution

When the parameter unit (FR-PU04V) is used, the Pr. 96 value is displayed during tuning on the main monitor as shown below. When the control panel (FR-DU04-1) is used, the same value as on the PU is only displayed.

When Pr. 96 = 1

- Parameter unit (FR-PU04V) main monitor

	1. Setting	2. Tuning in progress	3. Completion	4. Error-activated end (for inverter trip)
Display				

- Control panel (FR-DU04-1) display

	1. Setting	2. Tuning in progress	3. Completion	4. Error-activated end (for inverter trip)
Displayed value				

#### REMARKS

- Offline auto tuning time (factory setting)
  - 1: No-rotation mode: Approx. 25s
  - 2: Rotation mode: Approx. 40s

(Offline auto tuning time varies with the acceleration and deceleration time settings as indicated below.  
Offline auto tuning time = acceleration time + deceleration time + approx. 30s)

### (4) Ending the offline auto tuning

- Confirm the Pr. 96 value.
  - Normal end: "3" or "103" is displayed.
  - Error end: "9", "91", "92" or "93" is displayed.
  - Forced end: "8" is displayed.
- When tuning ended normally
 

For PU operation, press . For external operation, turn off the start signal (STF or STR) once. This operation resets the offline auto tuning and the PU's monitor display returns to the normal indication. (Without this operation, next operation cannot be started.) Do not change the Pr. 96 setting after completion of tuning. If the Pr. 96 setting is changed, tuning data is made invalid. If the Pr. 96 setting is changed, tuning must be performed again.
- When tuning was ended due to an error
 

Offline auto tuning did not end normally. (The motor constants have not been set.) Reset the inverter and start tuning all over again.
- Error display definitions

Error Display	Error Cause	Remedy
9	Inverter trip	Make setting again.
91	Current limit (stall prevention) function was activated.	Increase acceleration/deceleration time. Set "1" in Pr. 156.
92	Converter output voltage reached 75% of rated value.	Check for fluctuation of power supply voltage.
93	Calculation error	Check the motor wiring and make setting again.

No connection with motor will also result in "93" error.

5) When tuning was ended forcibly

Tuning is ended forcibly by pressing  or turning off the start signal (STF or STR) during tuning. In this case, offline auto tuning has not ended properly. (The motor constants have not been set.) Perform an inverter reset and restart tuning.

**REMARKS**

1. The motor constants measured once in the offline auto tuning are stored as parameters and their data are held until the offline auto tuning is performed again.
2. An instantaneous power failure occurring during tuning will result in a tuning error. After power is restored, the inverter goes into the ordinary operation mode. Therefore, when STF (STR) is on, the motor runs in the forward (reverse) rotation.
3. Any alarm occurring during tuning is handled as in the ordinary mode. Note that if an error retry has been set, retry is ignored.
4. The set speed monitor displayed during the offline auto tuning is 0r/min.

**⚠ CAUTION**

- ⚠ Note that the motor may start running suddenly.
- ⚠ When the offline auto tuning in the rotation mode is used in vertical lift application, e.g. an elevator, it may drop due to insufficient torque.

**3.12.4 Utilizing or changing offline auto tuning data for use**

<Setting the motor constants as desired>

Pr. 90 to Pr. 94 (motor constants) may be set as desired in either of two ways; the data measured in the offline auto tuning are read and utilized or changed, or the motor constants are set without the offline auto tuning data being used.

<Operating procedure>

1. Set the following value in Pr. 71 :
  - Mitsubishi standard motor ..... Pr. 71 = "4"
  - Mitsubishi constant-torque motor ..... Pr. 71 = "14"
  - Mitsubishi standard motor SF-JR (4P) (1.5kW or less) ..... Pr. 71 = "24"
  - SF-V5RU, SF-VR ..... Pr. 71 = "34"
2. Set "801" in Pr. 77.  
(The parameter values of Pr. 82 "motor excitation current" and Pr. 90 to Pr. 94 (motor constants) can be displayed. Though the parameter values of other than Pr. 82 and Pr. 90 to Pr. 94 can also be displayed, they are parameters for manufacturer setting and their values should not be changed.)
3. In the parameter setting mode, read the following parameters and set desired values.

Parameter Number	Name	Setting Range	Setting Increments	Factory Setting
82	Motor excitation current (no load current)	0 to ****, 9999	1	9999
90	Motor constant R1	0 to ****, 9999	1	9999
91	Motor constant R2	0 to ****, 9999	1	9999
92	Motor constant L1	0 to ****, 9999	1	9999
93	Motor constant L2	0 to ****, 9999	1	9999
94	Motor constant x	0 to ****, 9999	1	9999
859	Torque current	0 to ****, 9999	1	9999

**REMARKS**

When "0" (factory setting) is set in Pr. 684 "tuning data increment switchover", the motor constants are set in "internal variable increment". When "1" is set in Pr. 684, the motor constants are set in "mH, Ω, A". (can be set when Pr. 77 = "801")

4. Return the Pr. 77 setting to the original value.

**REMARKS**

1. Set "9999" in Pr. 90 to Pr. 94 to use the standard motor constants (including those for the constant-torque motor).
2. Set "3" (standard motor), "13" (constant-torque motor) or "23" (Mitsubishi standard SF-JR(4P) 1.5kW or less) in Pr. 71 to use the constants measured in the offline auto tuning. Set "4, 14 or 24" in Pr. 71 and change the motor constants to change the values measured in the offline auto tuning.
3. As the motor constants measured in the offline auto tuning have been converted into internal data (\*\*\*\*), refer to the following setting example when making setting:  
Setting example: To slightly increase Pr. 90 value (5%)  
When Pr. 90 is displayed "2516", set 2642, i.e. 2516 × 1.05=2641.8, in Pr. 90. (The value displayed has been converted into a value for internal use. Hence, simple addition of a given value to the displayed value has no significance.)
4. When "1" is set in Pr. 96, the last values of Pr. 82, Pr. 92, and Pr. 93 remain unchanged.

### 3.12.5 Setting the motor constants directly

Offline auto tuning is not used.

The Pr. 92 and Pr. 93 motor constants may either be entered in [ $\Omega$ ] or in [mH]. Before starting operation, confirm which motor constant unit is used. (Refer to page 120.)

- To enter the Pr. 92 and Pr. 93 motor constants in [ $\Omega$ ]

<Operating procedure>

1. After checking that the input motor constants are those for star connection or delta connection, set the Pr. 71 value as indicated below (When direct input is selected and offline auto tuning is performed, set "7, 8, 17 or 18") in Pr. 71. (Refer to page 125.).

		Star Connection Motor	Delta Connection Motor
Pr. 71 Setting	Standard motor	5	6
	Constant-torque motor	15	16

2. Set "801" in Pr. 77.

(The parameter values of the motor constants (Pr. 90 to Pr. 94) can be displayed. Though the parameter values of other than Pr. 90 to Pr. 94 can also be displayed, they are parameters for manufacturer setting and their values should not be changed.)

3. In the parameter setting mode, read the following parameters and set desired values.

$I_q$ =Torque,  $I_{100}$ =Rated current,  $I_0$ =No load current

$$I_q = \sqrt{I_{100}^2 - I_0^2}$$

Parameter Number	Name	Setting Range	Setting Increments	Factory Setting
82	Motor excitation current (no load current)	0 to 500A	0.01A	9999
90	Motor constant r1	0 to 50 $\Omega$ , 9999	0.001 $\Omega$	9999
91	Motor constant r2	0 to 50 $\Omega$ , 9999	0.001 $\Omega$	9999
92	Motor constant x1	0 to 50 $\Omega$ , 9999	0.001 $\Omega$	9999
93	Motor constant x2	0 to 50 $\Omega$ , 9999	0.001 $\Omega$	9999
94	Motor constant xm	0 to 500 $\Omega$ , 9999	0.01 $\Omega$	9999
859	Torque current	0 to 500A	0.01A	9999

4. Return the Pr. 77 setting to the original value.

5. Set Pr. 83 and Pr. 84.

Parameter Number	Name	Setting Range	Setting Increments	Factory Setting
83	Rated motor voltage	0 to 1000V	0.1V	200V/400V
84	Rated motor frequency	10 to 200Hz	0.01Hz	60Hz

#### CAUTION

1. Set "9999" in Pr. 90 to Pr. 94 to use the standard motor constants (including those for the constant-torque motor).
2. If "star connection" is mistaken for "delta connection" or vice versa during setting of Pr. 71, control cannot be exercised properly.

- To enter the Pr. 92 and Pr. 93 motor constants in [mH]

<Operating procedure>

1. After checking that the input motor constants are those for star connection or delta connection, set the Pr. 71 value as indicated below.

Pr. 71 Setting	Standard motor	0
	Constant-torque motor	10
	SF-V5RU	30

2. Set "801" in Pr. 77.

(The parameter values of the motor constants (Pr. 90 to Pr. 94) can be displayed. Though the parameter values of other than Pr. 90 to Pr. 94 can also be displayed, they are parameters for manufacturer setting and their values should not be changed.)

3. In the parameter setting mode, read the following parameters and set desired values.

Parameter Number	Name	Setting Range	Setting Increments	Factory Setting
82	Motor excitation current (no load current)	0 to 500A	0.01A	9999
90	Motor constant R1	0 to 50Ω, 9999	0.001Ω	9999
91	Motor constant R2	0 to 50Ω, 9999	0.001Ω	9999
92	Motor constant L1	0 to 1000mH, 9999	0.1mH	9999
93	Motor constant L2	0 to 1000mH, 9999	0.1mH	9999
94	Motor constant x	0 to 100%, 9999	0.1%	9999
859	Torque current	0 to 500A	0.01A	9999

4. Return the Pr. 77 setting to the original value.

5. Refer to the following table and set Pr. 83 and Pr. 84.

Parameter Number	Name	Setting Range	Setting Increments	Factory Setting
83	Rated motor voltage	0 to 1000V	0.1V	200V/400V
84	Rated motor frequency	10 to 200Hz	0.01Hz	60Hz

**CAUTION**

Set "9999" in Pr. 90 to Pr. 94 to use the standard motor constants (including those for the constant-torque motor).

**3.12.6 Direct input + offline auto tuning**

Perform offline auto tuning after directly inputting the motor constants.

1. Set Pr. 71.

Pr. 71 Setting	Description	
7	Star connection direct input + offline auto tuning	General-purpose motor
8	Delta connection direct input + offline auto tuning	
17	Star connection direct input + offline auto tuning	Constant-torque motor
18	Delta connection direct input + offline auto tuning	

2. Set the motor constants (Refer to page 124).

3. Set Pr. 96 to perform offline auto tuning (Refer to page 121).

### 3.13 Online auto tuning (Pr. 95)

Excellent torque accuracy is provided by temperature compensation even if the secondary resistance value of the motor varies with the rise in the motor temperature.

#### 3.13.1 Online auto tuning selection

(Pr. 95, Pr. 9, Pr. 71, Pr. 80, Pr. 81 speed torque position )

Parameter	Name	Factory Setting	Setting Range	Remarks
95	Online auto tuning selection	0	0, 1, 2	0: Online auto tuning not performed 1: Start time tuning (at start-up) 2: Adaptive magnetic flux observer (normal)
9	Electronic thermal O/L relay	0A	0 to 500A	Used as rated motor current and electronic thermal relay function parameters.
71	Applied motor	30	Refer to page 111 and make setting.	
80	Motor capacity	Inverter capacity	0.4 to 55kW	(Down to one rank lower than the inverter capacity)
81	Number of motor poles	4	2, 4, 6	

#### (1) Pr. 95 = "1" (start time tuning)

The current at a start is detected to compensate for the secondary resistance of the motor so that excellent characteristics are provided regardless of the change in value of the secondary resistance of the motor with the rise of the motor temperature.

#### CAUTION

1. Perform offline auto tuning in the rotation mode before performing online auto tuning with start time tuning. Data needs to be calculated.
2. For using start time tuning in vertical lift applications, examine the utilization of a brake sequence for the brake opening timing at a start. Though the tuning ends in about a maximum of 500ms after a start, torque is not provided fully during that period. Therefore, note that there may be a possibility of drop due to gravity.

#### REMARKS

To prevent delay at starting, X28 function which executes tuning before start signal input is provided. (Refer to page 33.)

**(2) Pr. 95 = "2" (normal tuning)/adaptive magnetic flux observer**

This function is effective for torque accuracy improvement when using the motor with encoder.

The current flowing in the motor and the inverter output voltage are used to estimate/observe the magnetic flux in the motor.

The magnetic flux of the motor is always detected with high accuracy so that excellent characteristics are provided regardless of the change in the temperature of the secondary resistance.

Set "2" when exercising vector control with encoder.

**CAUTION**

**For the SF-V5RU, SF-JR (with encoder) or SF-HRCA (with encoder), it is not necessary to perform offline auto tuning to select adaptive magnetic flux observer. (Note that it is necessary to perform offline auto tuning (non-rotation mode) for the wiring length resistance to be reflected on the control when the wiring length is long (30m or longer as reference).)**

**REMARKS**

1. Online auto tuning of the start time tuning is not enabled when the starting conditions of the inverter are not satisfied, e.g. the MRS is input, the preset speed is less than the starting speed (Pr. 13), during inverter error, etc.
2. Online auto tuning of the start time tuning does not operate during deceleration or at a restart during DC brake operation.
3. Invalid for jog operation.
4. The RUN signal is not output during online auto tuning of the start time tuning. The RUN signal turns on at a start.
5. If the period from an inverter stop to a restart is within 4s, online auto tuning of the start time tuning is performed but the tuning results are not reflected.
6. Automatic restart after instantaneous power failure overrides when automatic restart after instantaneous power failure is selected.
7. Zero current detection and output current detection are valid during online auto tuning.

**Pr. 96** ➡ Refer to page 120.

**Pr. 110, Pr. 111** ➡ Refer to Pr. 7 (page 78).

**Pr. 116** ➡ Refer to Pr. 42 (page 95).



### 3.14 Communication functions (Pr. 117 to Pr. 124, Pr. 342)

#### 3.14.1 Computer link operation (RS-485 communication)

(Pr. 117 to Pr. 124 **speed** **torque** **position**)

Used to perform required settings for communication between the inverter and personal computer. Using the inverter setup software (FR-SW1-SETUP-WE) enables efficient parameter setting, monitoring, etc.

- Communication operation can be performed from the PU connector of the inverter by RS-485 communication.

<Communication specifications>

<b>Conforming standard</b>		RS-485 Standard	
<b>Number of inverters connected</b>		1: N (max. 32 inverters)	
<b>Communication speed</b>		Selected among 19200, 9600 and 4800bps	
<b>Control protocol</b>		Asynchronous system	
<b>Communication method</b>		Half-duplex system	
<b>Communication specifications</b>	<b>Character system</b>	ASCII (7 bits/8 bits) selectable	
	<b>Stop bit length</b>	Selectable between 1 bit and 2 bits.	
	<b>Terminator</b>	CR/LF (presence/absence selectable)	
	<b>Check system</b>	<b>Parity check</b>	Selectable between presence (even/odd) and absence
		<b>Sum check</b>	Presence
<b>Waiting time setting</b>		Selectable between presence and absence	

- For parameter instruction codes, refer to the appended parameter instruction code list (page 213).

#### REMARKS

For computer link operation, set 65520 (HFFF0) as "8888" and 65535 (HFFFF) as "9999".

**<Setting>**

To make communication between the personal computer and inverter, the initial settings of the communication specifications must be made to the inverter. Data communication cannot be made if the initial settings are not made or there is any setting error.

**CAUTION**

**Always reset the inverter after making the initial settings of the parameters. Communication is disabled unless the inverter is reset after the communication-related parameter values have been changed.**

Parameter Number	Name	Factory Setting	Setting	Description	
117	Communication station number	0	0 to 31	Station number specified for communication from the PU connector. Set the inverter station numbers when two or more inverters are connected to one personal computer.	
118	Communication speed	192	48	4800bps	
			96	9600bps	
			192	19200bps	
119	Stop bit length/ data length	1	8 bits	0	Stop bit length 1 bit
				1	Stop bit length 2 bits
			7 bits	10	Stop bit length 1 bit
				11	Stop bit length 2 bits
120	Parity check presence/ absence	2	0	Absent	
			1	Odd parity present	
			2	Even parity present	
121	Number of communication retries	1	0 to 10	Set the permissible number of retries at occurrence of data receive error. If the number of consecutive errors exceeds the permissible value, the inverter will come to an alarm stop (E. PUE).	
			9999 (65535)	If a communication error occurs, the inverter will not come to an alarm stop. At this time, the inverter can be coasted to a stop by MRS or RESET input. During a communication error (H0 to H5), the minor fault signal (LF) is given to the open collector output. Allocate the used terminal with any of Pr. 190 to Pr. 192 and Pr. 195 (output terminal function selection).	
122*	Communication check time interval	0	0	No communication	
			0.1 to 999.8s	Set the communication check time [s] interval. If a no-communication state persists for longer than the permissible time, the inverter will come to an alarm stop (E. PUE).	
			9999	Communication check suspension	
123	Waiting time setting	9999	0 to 150ms	Set the waiting time between data transmission to the inverter and response.	
			9999	Set with communication data.	
124	CR/LF selection	1	0	Without CR/LF	
			1	With CR	
			2	With CR/LF	

\* When making communication, set any value other than 0 in Pr. 122 "communication check time interval".

**<Computer programming>**

**(1) Communication procedure**

Data communication between the computer and inverter is made in the following procedure.

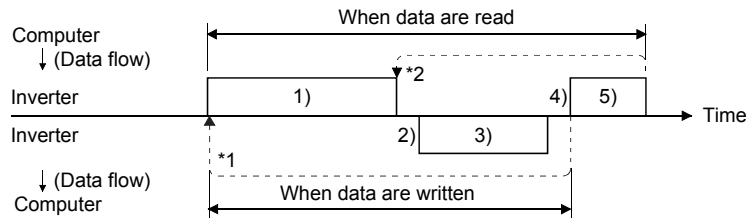

- \*1 If a retry must be made at occurrence of a data error, execute retry operation with the user program. The inverter comes to an alarm stop if the number of consecutive retries exceeds the parameter setting.
- \*2 On receipt of a data error occurrence, the inverter returns retry data 3 to the computer again. The inverter comes to an alarm stop if the number of consecutive data errors reaches or exceeds the parameter setting.

**(2) Communication operation presence/absence and data format types**

Communication operation presence/absence and data format types are as follows.

No.	Operation	Run Command	Running Speed	Parameter Write	Inverter Reset	Monitoring	Parameter Read	
1)	Communication request is sent to the inverter in accordance with the user program of the computer.	A'	A A''	A	A	B	B	
2)	Inverter data processing time	Present	Present	Present	Absent	Present	Present	
3)	Reply data from the inverter (Data 1 is checked for error)	No error* (Request accepted)	C	C	C	Absent	E E' E''	E
		With error (Request rejected)	D	D	D	Absent	F	F
4)	Computer processing delay time	Absent	Absent	Absent	Absent	Absent	Absent	
5)	Answer from computer in response to reply data 3 (Data 3 is checked for error)	No error* Inverter performs no processing	Absent	Absent	Absent	Absent	G	G
		With error Inverter re-outputs 3	Absent	Absent	Absent	Absent	H	H

\* In the communication request data from the computer to the inverter, 10ms or more is also required after "no data error (ACK)". (Refer to page 132.)

**(3) Data format**

Data are used in hexadecimal.

Data are automatically converted into ASCII for communication between the computer and inverter.

Data format types

1) Communication request data from the computer to the inverter

[Data write]

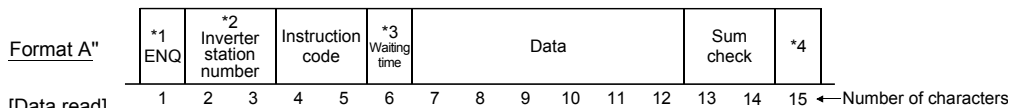
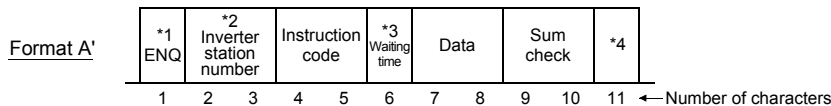
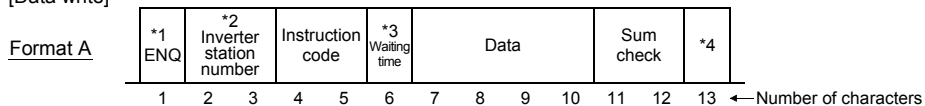

[Data read]

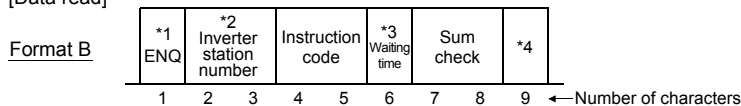

2) Reply data from the inverter to the computer during data write

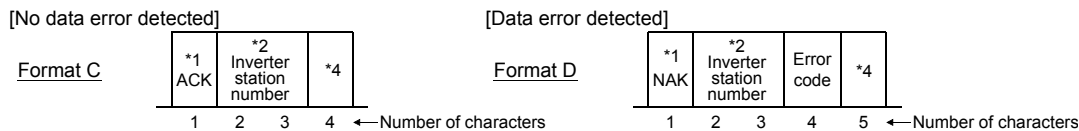

3) Reply data from the inverter to the computer during data read

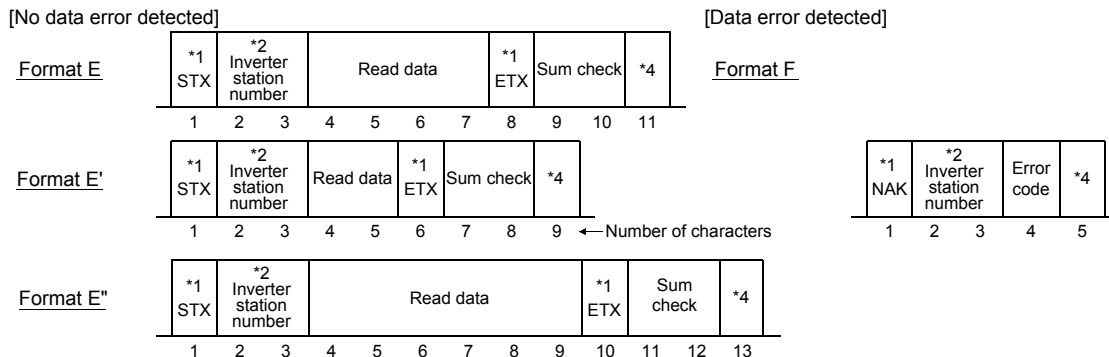

4) Send data from the computer to the inverter during data read

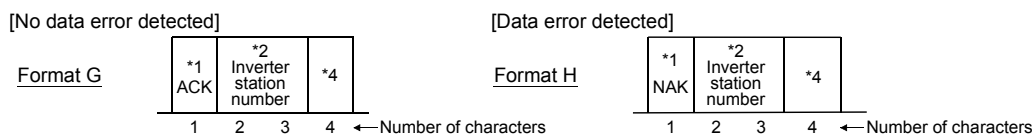

**CAUTION**

1. Indicate a control code. (Refer to (4)Data definitions)
2. Specify the inverter station numbers between H00 and H1F (stations 0 to 31) in hexadecimal.
3. When the Pr. 123 "waiting time setting" setting is other than "9999", create the communication request data without "waiting time" in the data format. (The number of characters is decremented by 1.)
4. CR, LF code  
 When data is transmitted from the computer to the inverter, CR (carriage return) and LF (line feed) codes are automatically set at the end of a data group on some computers. In this case, setting must also be made on the inverter according to the computer. Also, the presence or absence of the CR and LF codes can be selected using Pr. 124.

**(4) Data definitions**

1) Control codes

Signal Name	ASCII Code	Description
STX	H02	Start of Text (Start of data)
ETX	H03	End of Text (End of data)
ENQ	H05	Enquiry (Communication request)
ACK	H06	Acknowledge (No data error detected)
LF	H0A	Line Feed
CR	H0D	Carriage Return
NAK	H15	Negative Acknowledge (Data error detected)

2) Inverter station number

Specify the station number of the inverter which communicates with the computer.

3) Instruction code

Specify the processing request, e.g. operation or monitoring, given by the computer to the inverter. Hence, the inverter can be run and monitored in various ways by specifying the instruction codes as appropriate. (Refer to page 213.)

4) Data

Indicates the data such as speed and parameters transferred to and from the inverter. The definitions and ranges of set data are determined in accordance with the instruction codes. (Refer to page 213.)

5) Waiting time

Specify the waiting time between the receipt of data by the inverter from the computer and the transmission of reply data from the inverter. Set the waiting time in accordance with the response time of the computer between 0 and 150ms in 10ms increments. (Example: 1 = 10ms, 2 = 20ms)

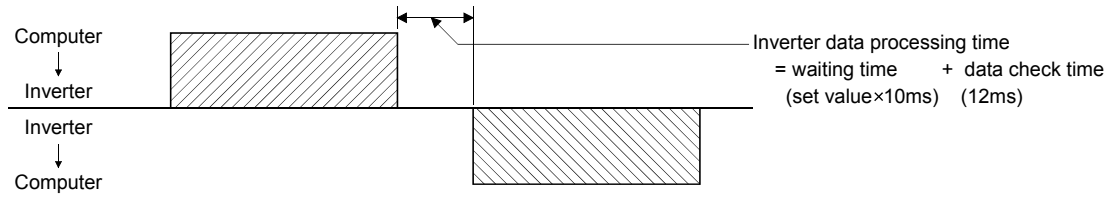

**CAUTION**

**When the Pr. 123 "waiting time setting" setting is other than 9999, create the communication request data without "waiting time" in the data format. (The number of characters decreases by 1.)**

6) Response time

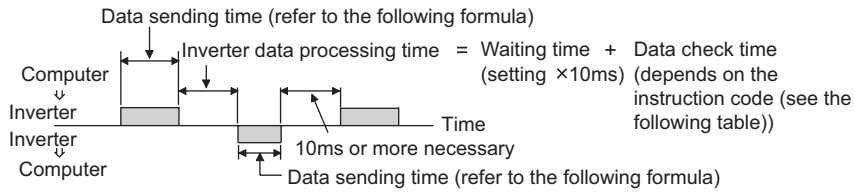

[Formula for data sending time]

$$\frac{1}{\text{Communication speed (bps)}} \times \text{Number of data characters (Refer to page 130)} \times \text{Communication specifications (total number of bits) (See below.)} = \text{Data send time (s)}$$

●Communication specifications

Name	Number of Bits
Stop bit length	1 bit 2 bits
Data length	7 bits 8 bits
Parity check	Yes 1 bit
	No 0

In addition to the above, 1 start bit is necessary.  
 Minimum number of total bits..... 9 bits  
 Maximum number of total bits..... 12 bits

●Data check time

Item	Check Time
Various monitors, run command, frequency setting (RAM)	< 12ms
Parameter read/write, frequency setting (E <sup>2</sup> PROM)	< 30ms
Parameter clear/all clear	< 5s
Reset command	No answer

7) Sum check code

The sum check code is 2-digit ASCII (hexadecimal) representing the lower 1 byte (8 bits) of the sum (binary) derived from the checked ASCII data.

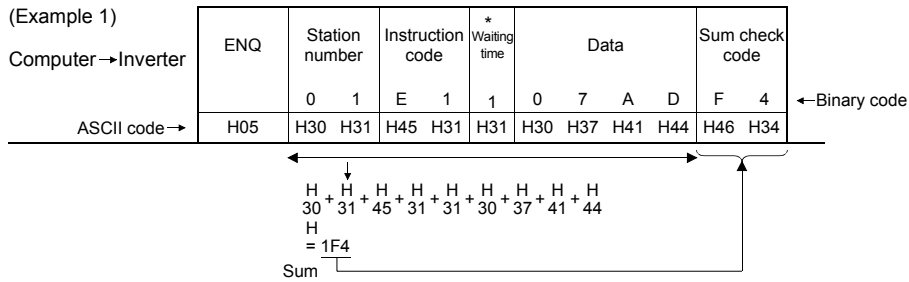

\*: When the Pr. 123 "waiting time setting" setting is other than 9999, create the communication request data without "waiting time" in the data format. (The number of characters decreases by 1.)

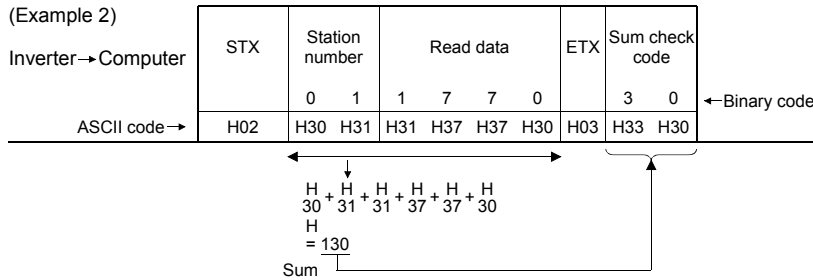

8) Error code

If any error is found in the data received by the inverter, its definition is sent back to the computer together with the NAK code. (Refer to page 137.)

**CAUTION**

1. When the data from the computer has an error, the inverter does not accept that data.
2. All data communication, e.g. run command or monitoring, are started when the computer gives a communication request. The inverter does not return any data without the computer's request. For monitoring, etc. therefore, design the program to cause the computer to provide a data read request as required.

**(5) Instructions for the program**

- 1) When data from the computer has any error, the inverter does not accept that error. Hence, in the user program, always insert a retry program for data error.
- 2) All data communication, e.g. run command or monitoring, are started when the computer gives a communication request. The inverter does not return any data without the computer's request. Hence, design the program so that the computer gives a data read request for monitoring, etc. as required.
- 3) Program example  
When the operation mode is switched to communication operation

```

10 OPEN "COM1:9600,E,8,2,HD" AS #1
20 COMST1,1,1:COMST1,2,1
30 ON COM(1)GOSUB'REC
40 COM(1)ON
50 D$="01FB10002"
60 S=0
70 FOR I=1 TO LEN(D$)
80 A$=MID$(D$,I,1)
90 A=ASC(A$)
100 S=S+A
110 NEXTI
120 D$=CHR$(&H5)+D$+RIGHT$(HEX$(S),2)
130 PRINT#1,D$
140 GOTO 50
1000 'REC
1010 IF LOC(1)=0 THEN RETURN
1020 PRINT "RECEIVE DATA"
1030 PRINT INPUT$(LOC(1),#1)
1040 RETURN
    
```

Initial setting of I/O file

- : Communication file opening
- : Circuit control signal (RS, ER) ON/OFF setting
- : Interrupt definition at data receive
- : Interrupt enable

Transmission data setting

Sum code calculation

Addition of control and sum codes

Data transmission

Interrupt data receive

: Interrupt occurrence at data receive

General flowchart

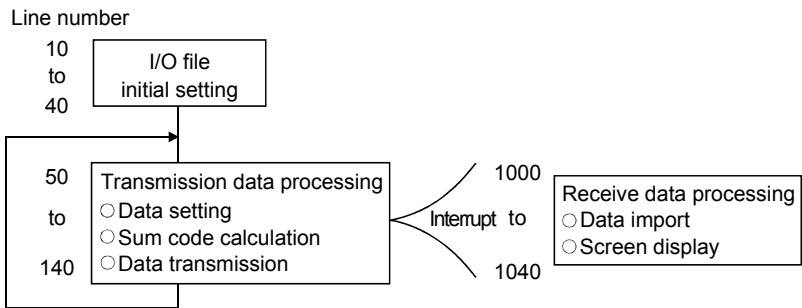

**⚠ CAUTION**

- ⚠ When the inverter's communication time interval is not set, interlocks are provided to disable operation to prevent hazard. Always set the communication check time interval before starting operation.
- ⚠ Data communication is not started automatically but is made only once when the computer provides a communication request. If communication is disabled during operation due to signal cable breakage etc., the inverter cannot be stopped. When the communication check time interval has elapsed, the inverter will come to an alarm stop (E.PUE).  
The inverter can be coasted to a stop by turning on its RES signal or by switching power off.
- ⚠ If communication is broken due to signal cable breakage, computer fault, etc. the inverter does not detect such a fault. This should be fully noted.

<Setting items and set data>

After completion of parameter setting, set the instruction codes and data and start communication from the computer to allow various types of operation control and monitoring.

No.	Item	Instruction Code	Description	Number of Data Digits																																																																																																
1	Operation mode	Read H7B	H0000: Communication option operation H0001: External operation H0002: Communication operation (PU connector)	4 digits																																																																																																
		Write HFB	H0000: Communication option operation H0001: External operation H0002: Communication operation (PU connector)																																																																																																	
2	Monitoring	Speed	H6F	H0000 to HFFFF: Speed (hexadecimal) in 1r/min increments (4 digits) [In 0.1r/min increments (6 digits) when HFF = 1.] When the Pr.37 and Pr.144 settings are changed to display items other than motor speed, values will not be read in 0.1r/min increments.	4 digits (6 digits)																																																																																															
		Output current	H70	H0000 to HFFFF: Output current (hexadecimal) in 0.01A increments	4 digits																																																																																															
		Output voltage	H71	H0000 to HFFFF: Output voltage (hexadecimal) in 0.1V increments	4 digits																																																																																															
		Special monitor	H72	H0000 to HFFFF: Monitor data selected in instruction code HF3	4 digits																																																																																															
		Special monitor selection No.	Read	H73	H01 to H0E: Monitor selection data			2 digits																																																																																												
					<table border="1"> <thead> <tr> <th>Data</th> <th>Description</th> <th>Increments</th> <th>Data</th> <th>Description</th> <th>Increments</th> </tr> </thead> <tbody> <tr> <td>H01</td> <td>Output frequency</td> <td>0.01Hz</td> <td>H10</td> <td>Output terminal status</td> <td>—</td> </tr> <tr> <td>H02</td> <td>Output current</td> <td>0.01A</td> <td>H11</td> <td>Load meter</td> <td>0.1%</td> </tr> <tr> <td>H03</td> <td>Output voltage</td> <td>0.1V</td> <td>H12</td> <td>Motor excitation current</td> <td>0.01A</td> </tr> <tr> <td>H05</td> <td>Speed setting*</td> <td>1r/min</td> <td>H13</td> <td>Position pulse</td> <td>—</td> </tr> <tr> <td>H06</td> <td>Running speed*</td> <td>1r/min</td> <td>H14</td> <td>Cumulative energization time</td> <td>1h</td> </tr> <tr> <td>H07</td> <td>Motor torque</td> <td>0.1%</td> <td>H17</td> <td>Actual operation time</td> <td>1h</td> </tr> <tr> <td>H08</td> <td>Converter output voltage</td> <td>0.1V</td> <td>H18</td> <td>Motor load factor</td> <td>0.1%</td> </tr> <tr> <td>H09</td> <td>Regenerative brake</td> <td>0.1%</td> <td>H20</td> <td>Torque command</td> <td>0.1%</td> </tr> <tr> <td>H0A</td> <td>Electronic overcurrent protection load factor</td> <td>0.1%</td> <td>H21</td> <td>Torque current command</td> <td>0.1%</td> </tr> <tr> <td>H0B</td> <td>Output current peak value</td> <td>0.01A</td> <td>H22</td> <td>Motor output</td> <td>0.01kW</td> </tr> <tr> <td>H0C</td> <td>Converter output voltage peak value</td> <td>0.1V</td> <td>H23</td> <td>Feedback pulse</td> <td>—</td> </tr> <tr> <td>H0F</td> <td>Input terminal status</td> <td>—</td> <td colspan="2"></td> <td></td> </tr> </tbody> </table>				Data	Description	Increments	Data	Description	Increments	H01	Output frequency	0.01Hz	H10	Output terminal status	—	H02	Output current	0.01A	H11	Load meter	0.1%	H03	Output voltage	0.1V	H12	Motor excitation current	0.01A	H05	Speed setting*	1r/min	H13	Position pulse	—	H06	Running speed*	1r/min	H14	Cumulative energization time	1h	H07	Motor torque	0.1%	H17	Actual operation time	1h	H08	Converter output voltage	0.1V	H18	Motor load factor	0.1%	H09	Regenerative brake	0.1%	H20	Torque command	0.1%	H0A	Electronic overcurrent protection load factor	0.1%	H21	Torque current command	0.1%	H0B	Output current peak value	0.01A	H22	Motor output	0.01kW	H0C	Converter output voltage peak value	0.1V	H23	Feedback pulse	—	H0F	Input terminal status	—																	
					Data	Description	Increments		Data	Description	Increments																																																																																									
					H01	Output frequency	0.01Hz		H10	Output terminal status	—																																																																																									
					H02	Output current	0.01A		H11	Load meter	0.1%																																																																																									
					H03	Output voltage	0.1V		H12	Motor excitation current	0.01A																																																																																									
			H05	Speed setting*	1r/min	H13	Position pulse		—																																																																																											
			H06	Running speed*	1r/min	H14	Cumulative energization time		1h																																																																																											
			H07	Motor torque	0.1%	H17	Actual operation time		1h																																																																																											
H08	Converter output voltage		0.1V	H18	Motor load factor	0.1%																																																																																														
H09	Regenerative brake		0.1%	H20	Torque command	0.1%																																																																																														
H0A	Electronic overcurrent protection load factor		0.1%	H21	Torque current command	0.1%																																																																																														
H0B	Output current peak value	0.01A	H22	Motor output	0.01kW																																																																																															
H0C	Converter output voltage peak value	0.1V	H23	Feedback pulse	—																																																																																															
H0F	Input terminal status	—																																																																																																		
Write	HF3	*0.1r/min increments when HFF = 1 <Input terminal monitor details> b15 _____ b0 _____ <table border="1"> <tr> <td>RES</td> <td>OH</td> <td>DI4</td> <td>DI3</td> <td>DI2</td> <td>DI1</td> <td>STR</td> <td>STF</td> </tr> </table>			RES	OH	DI4	DI3	DI2	DI1	STR	STF																																																																																								
		RES	OH	DI4	DI3	DI2	DI1	STR	STF																																																																																											
		<Output terminal monitor details> b15 _____ b0 _____ <table border="1"> <tr> <td>ABC</td> <td>DO3</td> <td>DO2</td> <td>DO1</td> </tr> </table>			ABC	DO3	DO2	DO1																																																																																												
		ABC	DO3	DO2	DO1																																																																																															
Alarm definition	H74 to H77	H0000 to HFFFF: Two latest alarm definitions Alarm definition display example (instruction code H74)  Read data: [Example] H30A0 (Previous alarm... THT) (Latest alarm .....OPT)																																																																																																		
		<table style="margin-left: 40px;"> <tr> <td style="text-align: right;">b15</td> <td>0</td> <td>0</td> <td>1</td> <td>1</td> <td>0</td> <td>0</td> <td>0</td> <td>0</td> <td>1</td> <td>0</td> <td>1</td> <td>0</td> <td>0</td> <td>0</td> <td>0</td> <td>0</td> <td>b0</td> </tr> <tr> <td></td> <td colspan="6" style="text-align: center;">Previous alarm (H30)</td> <td colspan="6" style="text-align: center;">Latest alarm (HA0)</td> <td></td> </tr> </table>			b15	0	0	1	1	0	0	0	0	1	0	1	0	0	0	0	0	b0		Previous alarm (H30)						Latest alarm (HA0)																																																																						
		b15	0	0	1	1	0	0	0	0	1	0	1	0	0	0	0	0	b0																																																																																	
			Previous alarm (H30)						Latest alarm (HA0)																																																																																											
		Alarm data																																																																																																		
		<table border="1"> <thead> <tr> <th>Data</th> <th>Description</th> <th>Data</th> <th>Description</th> <th>Data</th> <th>Description</th> </tr> </thead> <tbody> <tr> <td>H00</td> <td>No alarm</td> <td>H81</td> <td>LF</td> <td>HD3</td> <td>OD</td> </tr> <tr> <td>H10</td> <td>OC1</td> <td>H90</td> <td>OHT</td> <td>HD4</td> <td>ECA</td> </tr> <tr> <td>H11</td> <td>OC2</td> <td>HA0</td> <td>OPT</td> <td>HD5</td> <td>MB1</td> </tr> <tr> <td>H12</td> <td>OC3</td> <td>HA1</td> <td>OP1</td> <td>HD6</td> <td>MB2</td> </tr> <tr> <td>H20</td> <td>OV1</td> <td>HA2</td> <td>OP2</td> <td>HD7</td> <td>MB3</td> </tr> <tr> <td>H21</td> <td>OV2</td> <td>HA3</td> <td>OP3</td> <td>HD8</td> <td>MB4</td> </tr> <tr> <td>H22</td> <td>OV3</td> <td>HB0</td> <td>PE</td> <td>HD9</td> <td>MB5</td> </tr> <tr> <td>H30</td> <td>THT</td> <td>HB1</td> <td>PUE</td> <td>HDA</td> <td>MB6</td> </tr> <tr> <td>H31</td> <td>THM</td> <td>HB2</td> <td>RET</td> <td>HDB</td> <td>MB7</td> </tr> <tr> <td>H40</td> <td>FIN</td> <td>HC1</td> <td>CTE</td> <td>HDC</td> <td>EP</td> </tr> <tr> <td>H50</td> <td>IPF</td> <td>HC2</td> <td>P24</td> <td>HF1</td> <td>E.1</td> </tr> <tr> <td>H51</td> <td>UVT</td> <td>HC3</td> <td>P12</td> <td>HF2</td> <td>E.2</td> </tr> <tr> <td>H60</td> <td>OLT</td> <td>HD0</td> <td>OS</td> <td>HF3</td> <td>E.3</td> </tr> <tr> <td>H70</td> <td>BE</td> <td>HD1</td> <td>OSD</td> <td>HF6</td> <td>E.6</td> </tr> <tr> <td>H80</td> <td>GF</td> <td>HD2</td> <td>ECT</td> <td>HF7</td> <td>E.7</td> </tr> </tbody> </table>			Data	Description	Data	Description	Data	Description	H00	No alarm	H81	LF	HD3	OD	H10	OC1	H90	OHT	HD4	ECA	H11	OC2	HA0	OPT	HD5	MB1	H12	OC3	HA1	OP1	HD6	MB2	H20	OV1	HA2	OP2	HD7	MB3	H21	OV2	HA3	OP3	HD8	MB4	H22	OV3	HB0	PE	HD9	MB5	H30	THT	HB1	PUE	HDA	MB6	H31	THM	HB2	RET	HDB	MB7	H40	FIN	HC1	CTE	HDC	EP	H50	IPF	HC2	P24	HF1	E.1	H51	UVT	HC3	P12	HF2	E.2	H60	OLT	HD0	OS	HF3	E.3	H70	BE	HD1	OSD	HF6	E.6	H80	GF	HD2	ECT	HF7	E.7
		Data	Description	Data	Description	Data	Description																																																																																													
		H00	No alarm	H81	LF	HD3	OD																																																																																													
		H10	OC1	H90	OHT	HD4	ECA																																																																																													
		H11	OC2	HA0	OPT	HD5	MB1																																																																																													
		H12	OC3	HA1	OP1	HD6	MB2																																																																																													
H20	OV1	HA2	OP2	HD7	MB3																																																																																															
H21	OV2	HA3	OP3	HD8	MB4																																																																																															
H22	OV3	HB0	PE	HD9	MB5																																																																																															
H30	THT	HB1	PUE	HDA	MB6																																																																																															
H31	THM	HB2	RET	HDB	MB7																																																																																															
H40	FIN	HC1	CTE	HDC	EP																																																																																															
H50	IPF	HC2	P24	HF1	E.1																																																																																															
H51	UVT	HC3	P12	HF2	E.2																																																																																															
H60	OLT	HD0	OS	HF3	E.3																																																																																															
H70	BE	HD1	OSD	HF6	E.6																																																																																															
H80	GF	HD2	ECT	HF7	E.7																																																																																															



No.	Item	Instruction Code	Description	Number of Data Digits																									
3	Alarm definition all clear	HF4	H9696: Clears the error history.	4 digits																									
4	Run command	HFA	<table border="0"> <tr> <td style="text-align: center;">b7</td> <td style="text-align: center;">b0</td> <td></td> </tr> <tr> <td style="text-align: center;">0</td> <td style="text-align: center;">0</td> <td style="text-align: center;">0</td> </tr> <tr> <td style="text-align: center;">0</td> <td style="text-align: center;">0</td> <td style="text-align: center;">0</td> </tr> <tr> <td style="text-align: center;">0</td> <td style="text-align: center;">0</td> <td style="text-align: center;">1</td> </tr> <tr> <td style="text-align: center;">0</td> <td style="text-align: center;">0</td> <td style="text-align: center;">0</td> </tr> </table> <p>(For example 1)                      [Example 1] H02...Forward rotation                      [Example 2] H00...Stop</p> <p>b0: —                      b1: Forward rotation (STF)                      b2: Reverse rotation (STR)                      b3: —                      b4: —                      b5: —                      b6: —                      b7: —</p>	b7	b0		0	0	0	0	0	0	0	0	1	0	0	0	2 digits										
b7	b0																												
0	0	0																											
0	0	0																											
0	0	1																											
0	0	0																											
5	Inverter status monitor	H7A	<table border="0"> <tr> <td style="text-align: center;">b7</td> <td style="text-align: center;">b0</td> <td></td> </tr> <tr> <td style="text-align: center;">0</td> <td style="text-align: center;">0</td> <td style="text-align: center;">0</td> </tr> <tr> <td style="text-align: center;">0</td> <td style="text-align: center;">0</td> <td style="text-align: center;">0</td> </tr> <tr> <td style="text-align: center;">0</td> <td style="text-align: center;">0</td> <td style="text-align: center;">0</td> </tr> <tr> <td style="text-align: center;">0</td> <td style="text-align: center;">0</td> <td style="text-align: center;">1</td> </tr> <tr> <td style="text-align: center;">0</td> <td style="text-align: center;">0</td> <td style="text-align: center;">0</td> </tr> </table> <p>(For example 1)                      [Example 1] H02.....During forward rotation                      [Example 2] H80.....Stop due to alarm occurrence</p> <p>b0: Inverter running (RUN)                      b1: Forward rotation                      b2: Reverse rotation                      b3: DO1*                      b4: DO2*                      b5: DO3*                      b6: Speed detection (FB)                      b7: Alarm occurrence*</p> <p>* Output data varies with the settings of Pr. 190 to Pr. 192 and Pr. 195.</p>	b7	b0		0	0	0	0	0	0	0	0	0	0	0	1	0	0	0	2 digits							
b7	b0																												
0	0	0																											
0	0	0																											
0	0	0																											
0	0	1																											
0	0	0																											
6	Set speed write (E <sup>2</sup> PROM)	HEE	HFF=0 H0000 to H1C20: 1r/min increments (hexadecimal) (4 digits)	4 digits (6 digits)																									
	Set speed write (RAM)	HED	HFF=1 H0000 to H11940: 0.1r/min increments (hexadecimal) (6 digits) (0 to 3600r/min) To change the running speed consecutively, write data to the inverter RAM. (Instruction code: HED)																										
7	Set speed (E <sup>2</sup> PROM) read	H6E	HFF = 0 H0000 to H1C20: 1r/min increments (hexadecimal) (4 digits)	4 digits (6 digits)																									
	Set speed (RAM) read	H6D	HFF = 1 H0000 to 11940: 0.1r/min increments (hexadecimal) (6 digits) (0 to 3600r/min)																										
8	Inverter reset	HFD	H9696: Resets the inverter. As the inverter is reset at start of communication by the computer, the inverter cannot send reply data back to the computer.	4 digits																									
9	All parameter clear	HFC	<p>All parameters return to the factory settings.                      Any of four different clear operations is performed according to the data.</p> <table border="1" style="margin-left: auto; margin-right: auto;"> <thead> <tr> <th>Pr. / Data</th> <th>Communication Pr.</th> <th>Calibration Pr.</th> <th>Other Pr. *</th> <th>HEC HF3 HFF</th> </tr> </thead> <tbody> <tr> <td>H9696</td> <td style="text-align: center;">○</td> <td style="text-align: center;">×</td> <td style="text-align: center;">○</td> <td style="text-align: center;">○</td> </tr> <tr> <td>H9966</td> <td style="text-align: center;">○</td> <td style="text-align: center;">○</td> <td style="text-align: center;">○</td> <td style="text-align: center;">○</td> </tr> <tr> <td>H5A5A</td> <td style="text-align: center;">×</td> <td style="text-align: center;">×</td> <td style="text-align: center;">○</td> <td style="text-align: center;">○</td> </tr> <tr> <td>H55AA</td> <td style="text-align: center;">×</td> <td style="text-align: center;">○</td> <td style="text-align: center;">○</td> <td style="text-align: center;">○</td> </tr> </tbody> </table> <p>When all parameter clear is executed for H9696 or H9966, communication-related parameter settings also return to the factory settings. When resuming operation, set the parameters again.                      *Pr. 75 is not cleared.</p>	Pr. / Data	Communication Pr.	Calibration Pr.	Other Pr. *	HEC HF3 HFF	H9696	○	×	○	○	H9966	○	○	○	○	H5A5A	×	×	○	○	H55AA	×	○	○	○	4 digits
Pr. / Data	Communication Pr.	Calibration Pr.	Other Pr. *	HEC HF3 HFF																									
H9696	○	×	○	○																									
H9966	○	○	○	○																									
H5A5A	×	×	○	○																									
H55AA	×	○	○	○																									
10	Parameter write	H80 to HFD	Refer to the instruction code list (page 213) and write and/or read parameter values as required.	4 digits																									
11	Parameter read	H00 to H7B	When setting Pr. 100 and later, link parameter extended setting must be set.																										
12	Link parameter expansion setting	Read	H7F	<p>Parameter description is changed according to H00 to H09 setting. For details of the settings, refer to the parameter instruction code list (page 213).</p> <p style="text-align: center;"><b>CAUTION</b></p> <p><b>When the instruction code "HFF" was rewritten, increments of the speed monitor, write and read is changed.</b>                      HFF = "0" .....1r/min increments                      HFF = "1" .....0.1r/min increments                      HFF = more than "2" ... .1r/min increments</p>	2 digits																								
		Write	HFF																										

No.	Item		Instruction Code	Description	Number of Data Digits
13	Second parameter changing (Code FF=1)	Read	H6C	When reading/setting the bias/gain (Instruction code H5E to H61, HDE to HE1) parameters H00: Speed/torque H01: Analog H02: Analog value of terminal (When written, the data value is any 4-digit value.)	2 digits
		Write	HEC		

**REMARKS**

For the instruction codes HFF, HEC and HF3, their values are held once written but cleared to zero when an inverter reset or all clear is performed.

<Error code list>

The corresponding error code in the following list is displayed if an error is detected in any communication request data from the computer.

Error Code	Error Item	Error Definition	Inverter Side Operation
H0	Computer NAK error	The number of errors consecutively detected in communication request data from the computer is greater than the allowed number of retry times.	Brought to an alarm stop (E. PUE) if error occurs continuously more than the allowable number of retry times.
H1	Parity error	The parity check result does not match the specified parity.	
H2	Sum check error	The sum check code in the computer does not match that of the data received by the inverter.	
H3	Protocol error	Data received by the inverter is in the wrong protocol, data receive is not completed within the given time, or CR and LF are not as set in the parameter.	
H4	Framing error	The stop bit length differs from the initial setting.	
H5	Overrun	New data has been set by the computer before the inverter completes receiving the preceding data.	
H6	—	—	—
H7	Character error	The character received is invalid (other than 0 to 9, A to F, control code).	Does not accept receive data but is not brought to alarm stop.
H8	—	—	—
H9	—	—	—
HA	Mode error	Parameter write was attempted in other than the computer link operation mode or during inverter operation.	Does not accept or receive data but is not brought to alarm stop.
HB	Instruction code error	The specified command does not exist.	
HC	Data range error	Invalid data has been specified for parameter, running frequency write, etc.	
HD	—	—	—
HE	—	—	—
HF	—	—	—

**(6) Communication specifications for RS-485 communication**

Operation Location	Item	Operation Mode		
		Communication operation from PU connector	External operation	Computer link operation (When plug-in option is used)
On-computer user program from PU connector	Run command (start)	Enabled	Disabled	Disabled
	Running speed setting	Enabled	Enabled (Combined operation mode)	Disabled
	Monitoring	Enabled	Enabled	Enabled
	Parameter write	Enabled (*4)	Disabled (*4)	Disabled (*4)
	Parameter read	Enabled	Enabled	Enabled
	Inverter reset	Enabled (*2)	Enabled (*2)	Enabled (*2)
	Stop command (*3)	Enabled	Enabled	Enabled
On-computer user program from plug-in option	Run command	Disabled	Disabled	Enabled (*1)
	Running speed setting	Disabled	Disabled	Enabled (*1)
	Monitoring	Enabled	Enabled	Enabled
	Parameter write	Disabled (*4)	Disabled (*4)	Enabled (*4)
	Parameter read	Enabled	Enabled	Enabled
	Inverter reset	Disabled	Disabled	Enabled (*2)
	Stop command (*3)	Disabled	Disabled	Enabled
Control circuit terminal	Inverter reset	Enabled	Enabled	Enabled
	Run command	Disabled	Enabled	Enabled (*1)
	Speed setting	Disabled	Enabled	Enabled (*1)

(\*1) As set in the Pr. 79 external/PU combined mode.

(\*2) At occurrence of RS-485 communication error, the inverter cannot be reset from the computer.

(\*3) As set in Pr. 75.

(\*4) As set in Pr. 77.

**(7) Operation at alarm occurrence**

Alarm Location	State	Operation Mode		
		Communication operation (PU connector)	External operation	Computer link operation (When plug-in option is used)
Inverter fault	Inverter operation	Stop	Stop	Stop
	Communication	PU connector	Continued	Continued
		Plug-in option	Continued	Continued
Communication error (Communication from PU connector)	Inverter operation	Stop/continued (*5)	Continued	Continued
	Communication	PU connector	Stop	Stop
		Plug-in option	Continued	Continued

(\*5) Can be selected using the parameter (factory-set to Continued).

**(8) Communication error**

Alarm Location	Error Message
Communication error (Error in communication from PU connector)	E.PUE

### 3.14.2 E<sup>2</sup>PROM write selection (Pr. 342)

You can select either E<sup>2</sup>PROM or RAM to which parameters to be written during computer link communication operation (RS-485 communication by PU connector) and operation with a communication option. When changing the parameter values frequently, write them to the RAM (Pr. 342 = 1).

Parameter	Name	Factory Setting	Setting Value	
			342	E <sup>2</sup> PROM write selection
			1	Write into RAM

#### REMARKS

When the parameter setting is "not written to E<sup>2</sup>PROM" (setting = 1), the settings return to the original values (values saved in the E<sup>2</sup>PROM) at power on reset or terminal reset.

Pr. 342 Setting	
0 (factory setting)	E <sup>2</sup> PROM write Powering off the inverter will not erase the changed parameter values.
1	RAM write Powering off the inverter will erase the changed parameter values. Therefore, the parameter values available when power is switched on again are the values stored in E <sup>2</sup> PROM last time.

## 3.15 PID control (Pr. 128 to Pr. 134)

### 3.15.1 PID control (Pr. 128 to Pr. 134 speed)

The inverter can be used to exercise process control, e.g. flow rate, air volume or pressure.

- The voltage input signal (0 to ±10V) is used as a feedback value to constitute a feedback system for PID control.

Parameter Number	Name	Factory Setting	Setting Range	Remarks
128	PID action selection	10	10, 11, 30, 31	
129	PID proportional band	100%	0.1 to 1000%, 9999	9999: No proportional control
130	PID integral time	1s	0.1 to 3600s, 9999	9999: No integral control
131	Upper limit	9999	0 to 100%, 9999	9999: Function invalid
132	Lower limit	9999	0 to 100%, 9999	9999: Function invalid
133	PID action set point for PU operation	0%	0 to 100%	
134	PID differential time	9999	0.01 to 10.00s, 9999	9999: No differential control

#### <Setting>

#### (1) Basic PID control configuration

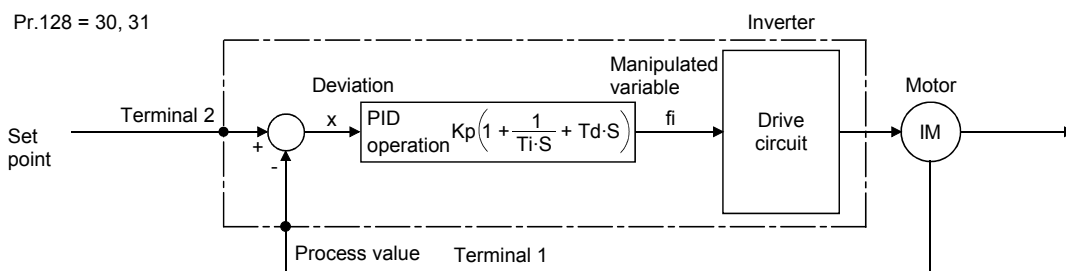
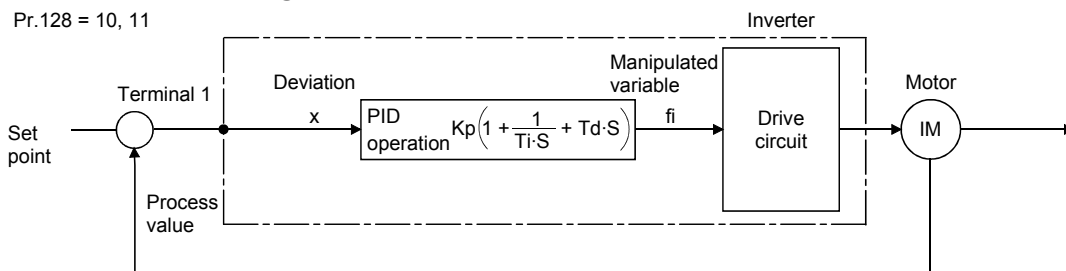

Kp: Proportional constant    Ti: Integral time    S: Operator    Td: Differential time

**(2) PID action overview**

1) PI action

A combination of proportional control action (P) and integral control action (I) for providing a manipulated variable in response to deviation and changes with time.

[Operation example for stepped changes of measured value]

**CAUTION**  
**PI action is the sum of P and I actions.**

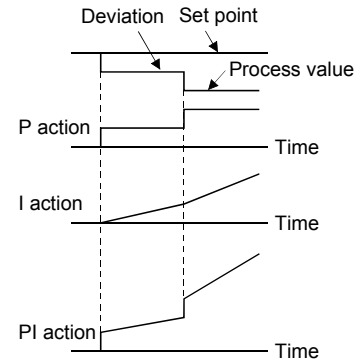

2) PD action

A combination of proportional control action (P) and differential control action (D) for providing a manipulated variable in response to deviation speed to improve the transient characteristic.

[Operation example for proportional changes of measured value]

**CAUTION**  
**PD action is the sum of P and D actions.**

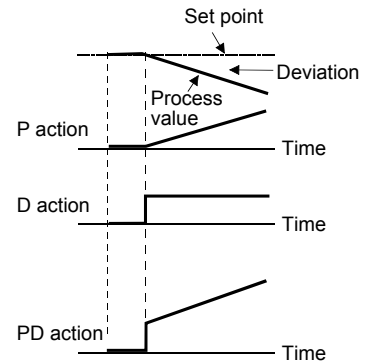

3) PID action

The PI action and PD action are combined to utilize the advantages of both actions for control.

**CAUTION**  
**The PID action is the sum of P and I and D actions.**

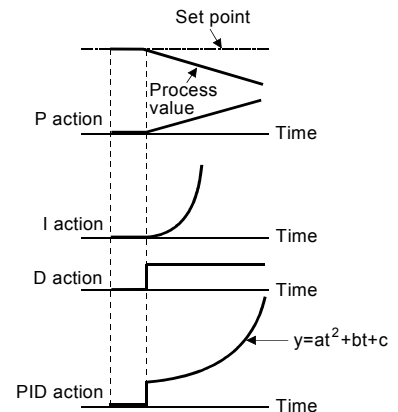

4) Reverse action

Increases the manipulated variable (output speed) if deviation X (set point - measured value) is positive, and decreases the manipulated variable (output speed) if deviation is negative.

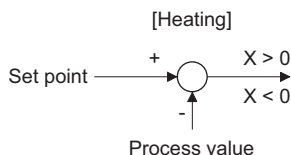

Cold → Increase the manipulated variable  
 Hot → Decrease the manipulated variable

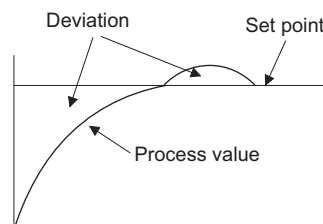

5) Forward action

Increases the manipulated variable (output speed) if deviation X (set point - measured value) is negative, and decreases the manipulated variable (output speed) if deviation is positive.

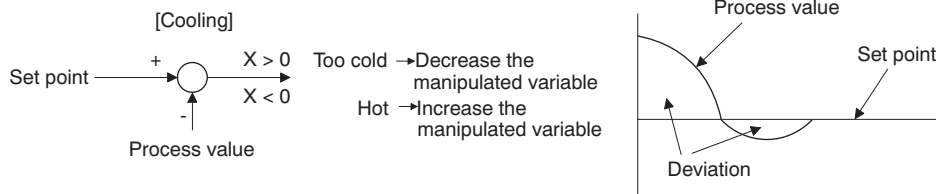

Relationships between deviation and manipulated variable (output speed)

	Deviation	
	Positive	Negative
Reverse Action	↗	↘
Forward Action	↘	↗

(3) Wiring example

Pr.128 = 10, 11

Pr.128 = 30, 31

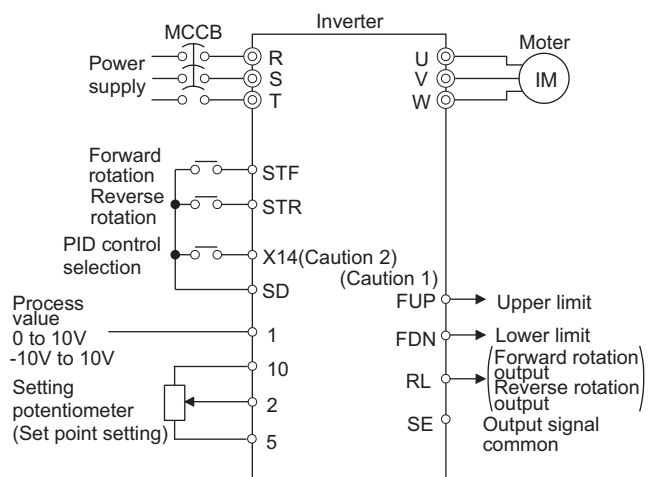
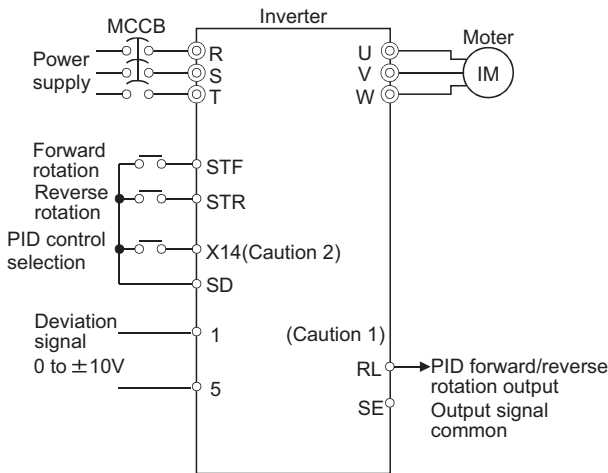

**CAUTION**

1. Set "16" to the output signal terminal used (Pr. 190 to Pr. 192, Pr. 195). (Refer to page 152.)
2. Set "14" to the input signal terminal used (Pr. 180 to Pr. 183, Pr. 187). (Refer to page 150.)

**(4) I/O signals**

- To start PID control, turn on the X14 signal. When this signal is off, normal inverter operation is performed without the PID action being done.

Signal	Terminal Used	Function	Description	Remarks		
Input	X14	Depending on Pr. 180 to 183, Pr. 187	PID control selection	Turn on X14 to select PID control.	Set any of 10, 11, 30 and 31 in Pr. 128.	
	1	1	Deviation signal input	Enter the deviation signal of the 0 to ±10V signal calculated externally.	When Pr. 128 = 10, 11	
			measured value input	Enter the measured value signal from the detector.	When Pr. 128 = 30, 31	
	2	2	Set point input	Enter the set point for PID control.	When Pr. 128 = 30, 31	Refer to Pr. 902 and Pr. 903 (page 190) for calibration.
	5	5	Common terminal to the PID control setting signal (terminal 2, 1)	Isolated from terminals SD and SE. Do not earth (ground).		
Output	RL		PID forward/reverse rotation output	"Hi" is output to indicate that the output indication of the parameter unit is forward rotation (FWD) or "Low" to indicate that it is reverse rotation (REV) or stop (STOP).	(When Pr. 128 = 10, 11, 30, 31)	
	FUP	Depending on Pr. 190 to 192, Pr. 195	Upper limit output	Output to indicate that the measured value signal exceeded the upper limit value.	When Pr. 128 = 30, 31	
	FDN		Lower limit output	Output to indicate that the measured value signal exceeded the lower limit value.		
	SE	SE	Output terminal common	Common terminal for terminal RL		Open collector output

- When entering the externally calculated deviation signal, enter it across terminals 1-5. At this time, set "10" or "11" in Pr. 128.
- The set point is given to across inverter terminals 2-5 or set in Pr.133. The measured value signal is input to across inverter terminals 1-5. At this time, set "30" or "31" in Pr.128.  
Analog input voltage range of the measured value differs according to the year and month when the inverter was manufactured
  - In and before June 2003 ... 0V to 10V (input of -10V to 0V are regarded as 0V)
  - In and after July 2003..... -10V to 10V
 Check the rating plate for the month when the inverter was manufactured. (Refer to page 220.)

Item	Entry Method	Description	
Deviation signal	Across terminals 1-5	Set -10V as -100% Set 0V as 0% and +10V as +100%.*	When 10 or 11 is set in Pr. 128, terminal 1 gives the deviation input signal independently of the Pr. 868 setting.
Set point	Across terminals 2-5	Set 0V as 0% and 10V as +100%.*	When 30 or 31 is set in Pr. 128, terminal 1 gives the measured value input signal independently of the Pr. 868 setting.
	Pr.133	Set the set point (%) in Pr. 133.	
Measured value	Across terminals 1-5	Set -10V as -100%, 0V as 0% and +10V as +100%.*	

\*: The value changes by calibration

(5) Parameter setting

Parameter Number	Setting	Name	Description		
128	10	PID action selection	For heating, pressure control, etc.	Deviation value signal input (terminal 1)	PID reverse action
	11		For cooling, etc.		PID forward action
	30		For heating, pressure control, etc.	measured value input (terminal 1)	PID reverse action
	31		For cooling, etc.		PID forward action
129	0.1 to 1000%	PID proportional band	If the proportional band is narrow (parameter setting is small), the manipulated variable varies greatly with a slight change of the measured value. Hence, as the proportional band narrows, the response sensitivity (gain) improves but the stability deteriorates, e.g. hunting occurs. Gain $K_p = 1/\text{proportional band}$		
	9999		No proportional control		
130	0.1 to 3600s	PID integral time	Time required for only the integral (I) action to provide the same manipulated variable as that for the proportional (P) action. As the integral time decreases, the set point is reached earlier but hunting occurs more easily.		
	9999		No integral control.		
131	0 to 100%	Upper limit	Set the upper limit value. If the feedback value exceeds the setting, the FUP signal is output. (measured value of 0V is equivalent to 0% and 10V to 100%.)*		
	9999		No function		
132	0 to 100%	Lower limit	Set the lower limit value. (If the measured value goes out of the setting range, an alarm can be output. In this case, the measured value of 0V is equivalent to 0% and 10V to 100%.)*		
	9999		No function		
133	0 to 100%	PID action set point for PU operation	Only valid for the PU command in the PU operation or PU/external combined mode. For external operation, the voltage across terminals 2-5 is the set point. (Pr. 902 value is equivalent to 0% and Pr. 903 value to 100%.)		
134	0.01 to 10.00s	PID differential time	Time required for only the differential (D) action to provide the same manipulated variable as that for the proportional (P) action. As the differential time increases, greater response is made to a deviation change.		
	9999		No differential control.		

\*: The value changes by calibration

(6) Adjustment procedure

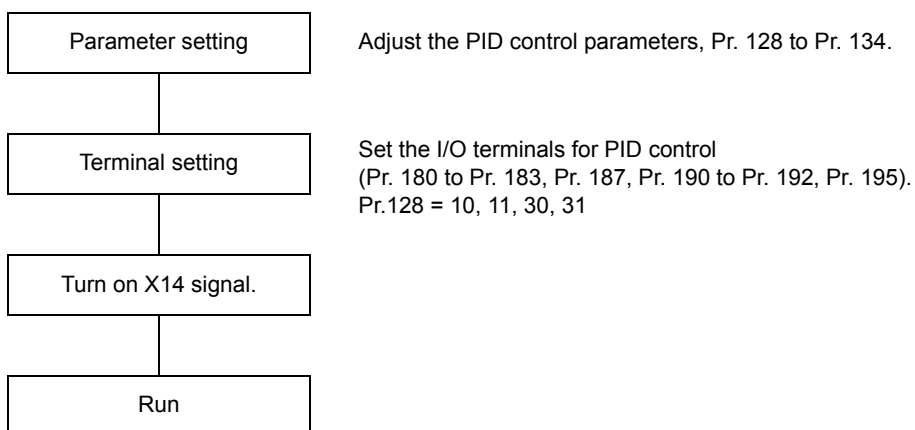



**(7) Adjustment example**

(A detector of 0V at 0°C and 10V at 50°C is used to adjust the room temperature to 25°C under PID control. The set point is given to across inverter terminals 2-5 (0 to 10V).)

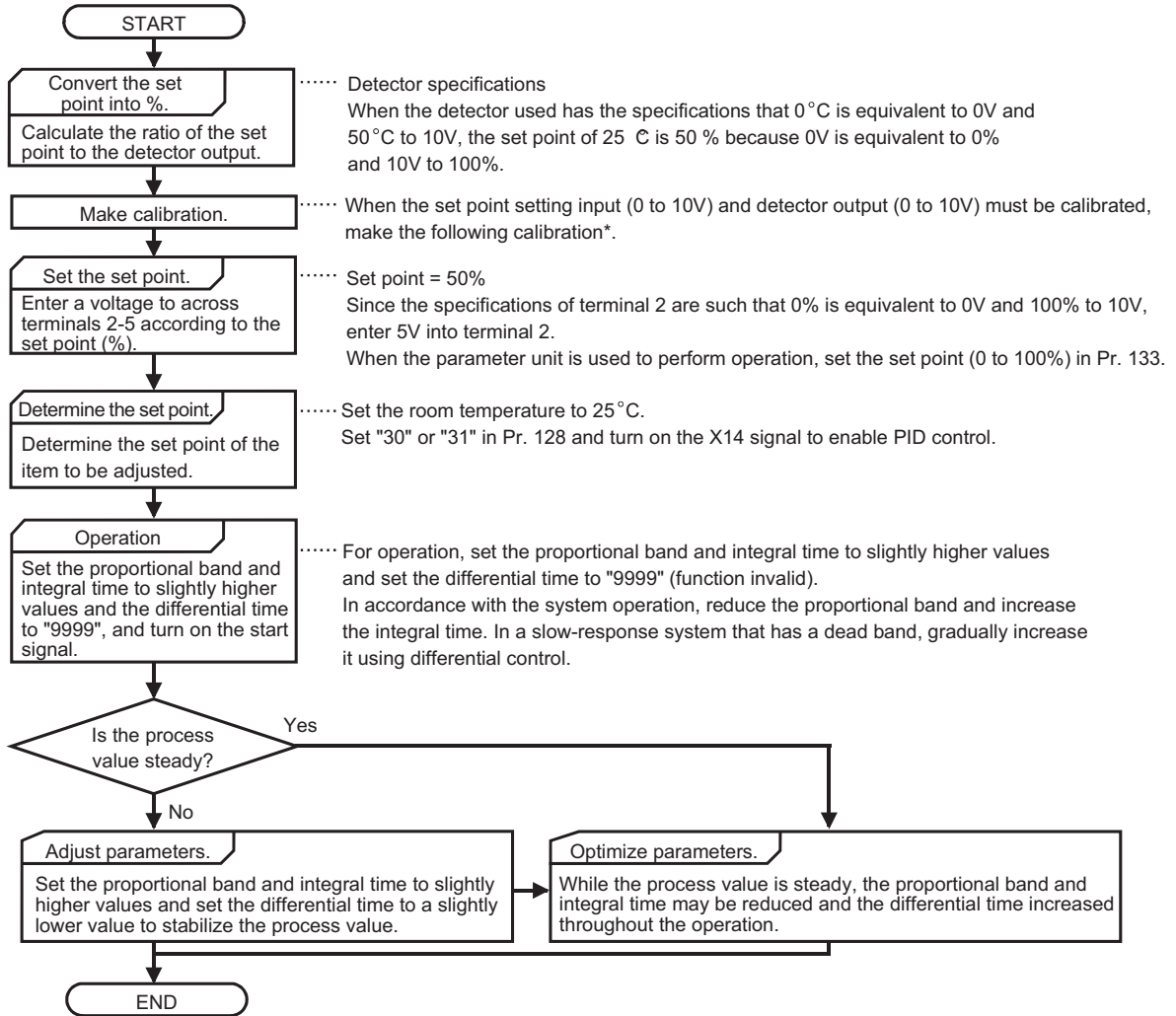

\* When calibration is required, use Pr. 902, Pr.903, Pr.917, Pr.918 to calibrate the set point setting input and detector output. Calibration is made in the PU mode during an inverter stop.

**(8) Calibration example**

**<Set point input calibration>**

1. Apply the input voltage of 0% set point setting (e.g. 0V) to across terminals 2-5.
2. Make calibration using Pr. 902. At this time, enter the speed output by the inverter at the deviation of 0% (e.g. 0r/min).
3. Apply the voltage of 100% set point setting (e.g. 10V) to across terminals 2-5.
4. Make calibration using Pr. 903. At this time, enter the speed output by the inverter at the deviation of 100% (e.g. 1500r/min).

**<Detector output calibration>**

1. Apply the output current of 0% detector setting (e.g. 0V) to across terminals 1-5.
2. Make calibration using Pr. 917.
3. Apply the output current of 100% detector setting (e.g. 5V) to across terminals 1-5.
4. Make calibration using Pr. 918.

**CAUTION**

The frequencies set in Pr. 917 and Pr. 918 should be the same as set in Pr. 902 and Pr. 903.

The results of the above calibration are as shown below:

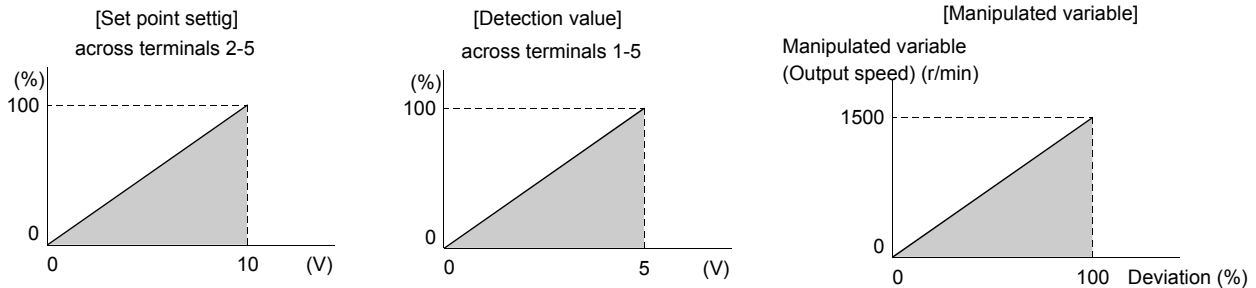

**CAUTION**

1. If the multi-speed (RH, RM, RL signal) or jog operation (jog) signal is entered with the X14 signal on, PID control is stopped and multi-speed or jog operation is started.
2. When "6" (switchover mode) is selected for Pr. 79, PID is made invalid.
3. When "1" (online auto tuning) is selected for Pr. 95, PID control is made invalid.
4. Changing the terminal function using any of Pr. 180 to 183 and Pr. 187 and Pr. 190 to 192 and Pr. 195 may affect the other functions. Confirm the functions of the corresponding terminals before making setting.
5. When PID control is selected, the minimum speed is as set in Pr. 902 and the maximum speed is as set in Pr. 903.  
(Pr. 1 "maximum speed" and Pr. 2 "minimum speed" settings are also valid.)

**Related parameters**

- Pr. 73 "speed setting signal" (Refer to page 113.)
- Pr. 79 "operation mode selection" (Refer to page 117.)
- Pr. 180 to Pr. 183, Pr. 187 (input terminal function selection) (Refer to page 150.)
- Pr. 191 to Pr. 192, Pr. 195 (output terminal function selection) (Refer to page 152.)
- Pr. 902, Pr. 903, Pr. 917, Pr. 918 (Speed setting terminal bias/gain) (Refer to page 190.)

Pr. 140 to Pr. 143 ➡ Refer to Pr. 29 (page 89)

Pr. 144 ➡ Refer to Pr. 37 (page 93)

### 3.16 Current detection (Pr. 150 to Pr. 153)

#### 3.16.1 Output current detection function (Pr. 150, Pr. 151 speed torque position)

- If the output current remains higher than the Pr. 150 setting during inverter operation for longer than the period set in Pr. 151, the output current detection signal (Y12) is output from the inverter's open collector output terminal.

(Use any of Pr. 190 to Pr. 192 and Pr. 195 to assign the terminal used for Y12 signal output.)

Parameter	Name	Factory Setting	Setting Range
150	Output current detection level	150%	0 to 200.0%
151	Output current detection period	0	0 to 10s

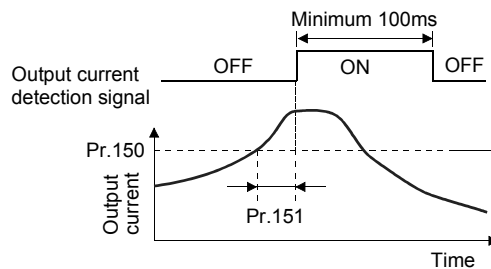

#### <Setting>

Refer to the following table and set the parameters.

Parameter	Description
150	Set the output current detection level. 100% is the rated inverter current.
151	Set the output current detection period. Set the period from when the output current has risen above the setting until the output current detection signal (Y12) is output.

#### CAUTION

1. Once turned on, the output current detection signal is held on for at least 100ms.
2. This function is also valid during execution of the online or offline auto tuning.
3. Changing the terminal function using any of Pr. 190 to 192 and Pr. 195 may affect the other functions. Confirm the functions of the corresponding terminals before making setting.
4. When "0" is set in Pr. 151, the output current detection period is about 50ms.

#### Related parameters

- Y12 signal terminal assignment ⇒ Pr. 190 to Pr. 192, Pr. 195 (output terminal function selection) (Refer to page 152.)

3.16.2 Zero current detection (Pr. 152, Pr. 153) speed torque position

When the inverter's output current falls to "0", torque will not be generated. This may cause a gravity drop to occur when the inverter is used in vertical lift application.

To prevent this, the output current "zero" signal can be output from the inverter to close the mechanical brake when the output current has fallen to "zero".

- If the output current remains lower than the Pr. 152 setting during inverter operation for longer than the period set in Pr. 153, the zero current detection (Y13) signal is output from the inverter's open collector output terminal.

(Use any of Pr. 190 to Pr. 192 and Pr. 195 to assign the terminal used for Y13 signal output.)

Parameter	Name	Factory Setting	Setting Range
152	Zero current detection level	5.0%	0 to 200.0%
153	Zero current detection period	0.5s	0 to 1s

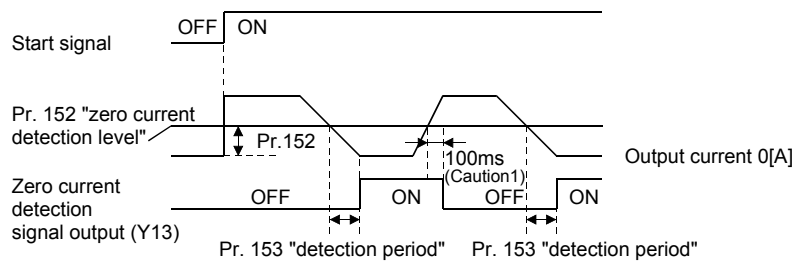

<Setting>

Refer to the following table and set the parameters.

Parameter	Description
152	Set the zero current detection level. Set this parameter to define the percentage of the rated current at which the zero current will be detected.
153	Set the zero current detection period. Set this parameter to define the period from when the output current drops below the Pr. 152 value until the zero current detection signal (Y13) is output.

**CAUTION**

1. If the current rises above the preset detection level and the condition is not satisfied, the zero current detection signal is held on for about 100ms.
2. This function is also valid during execution of the online auto tuning.
3. Changing the terminal function using any of Pr. 190 to 192 and Pr. 195 may affect the other functions. Confirm the functions of the corresponding terminals before making setting.
4. When "0 to 0.04" is set in Pr. 153, the zero current detection period is about 50ms.

**⚠ CAUTION**

- ⚠ The zero current detection level setting should not be too high, and the zero current detection period setting not too long. Otherwise, the detection signal may not be output when torque is not generated at a low output current.
- ⚠ To prevent the machine and equipment from resulting in hazardous conditions by use of the zero current detection signal, install a safety backup such as an emergency brake.

**Related parameters**

- Y13 signal terminal assignment ⇒ Pr. 190 to Pr. 192, Pr. 195 (output terminal function selection) (Refer to page 152.)

### 3.17 Auxiliary functions (Pr. 156, Pr. 157)

#### 3.17.1 Stall prevention operation selection (Pr. 156 speed torque position)

Make setting to disable stall prevention activated by overcurrent and/or to prevent the inverter from resulting in an overcurrent trip if an excessive current flows due to sudden load fluctuation or running inverter output side ON-OFF (to disable fast response current limit that limits the current). An OL signal output delay can be set in Pr. 157.

- Stall prevention (only during V/F control)  
Automatically change the output frequency of the inverter to reduce the amount of current when the current flow exceeds the current limit value.
- Fast response current limit  
Shut off the output of the inverter to prevent overcurrent when the current flows exceeds the current limit value.

Parameter	Name	Factory Setting	Setting Range	Remarks
156	Stall prevention operation selection	1	0 to 31, 100, 101	Extended mode

Setting	Fast Response Current Limit ○ : Activated ● : Not activated	Stall Prevention ○ : Activated			OL Signal Output ○ : Operation continued ● : Operation not continued *1
		Acceleration	Constant speed	Deceleration	
0	○	○	○	○	○
1	●	○	○	○	○
2	○	●	○	○	○
3	●	●	○	○	○
4	○	○	●	○	○
5	●	○	●	○	○
6	○	●	●	○	○
7	●	●	●	○	○
8	○	○	○	●	○
9	●	○	○	●	○
10	○	●	○	●	○
11	●	●	○	●	○
12	○	○	●	●	○
13	●	○	●	●	○
14	○	●	●	●	○
15	●	●	●	●	—*2

Setting	Fast Response Current Limit ○ : Activated ● : Not activated	Stall Prevention ○ : Activated			OL Signal Output ○ : Operation continued ● : Operation not continued *1
		Acceleration	Constant speed	Deceleration	
16	○	○	○	○	●
17	●	○	○	○	●
18	○	●	○	○	●
19	●	●	○	○	●
20	○	○	●	○	●
21	●	○	●	○	●
22	○	●	●	○	●
23	●	●	●	○	●
24	○	○	○	○	●
25	●	○	○	●	●
26	○	●	○	●	●
27	●	●	○	●	●
28	○	○	●	●	●
29	●	○	●	●	●
30	○	●	●	●	●
31	●	●	●	●	—*2

100 *3	Driving	○	○	○	○	○
	Regeneration	●	●	●	●	—*2

101 *3	Driving	●	○	○	○	○
	Regeneration	●	●	●	●	—*2

\*1 When "Operation not continued for OL signal output" is selected, the "E.O.L.T" alarm code (stopped by stall prevention) is displayed and operation stopped.

\*2 Since both fast response current limit and stall prevention are not activated, OL signal and E.O.L.T are not output.

\*3 The settings "100" and "101" allow operations to be performed in the driving and regeneration modes, respectively. The setting "101" disables the fast response current limit in the driving mode.

**CAUTION**

- When torque limit (stall prevention) activates, acceleration/deceleration may not be made according to the preset acceleration/deceleration time. Set Pr. 156 and stall prevention operation level to the optimum values.
- In vertical lift applications, make setting so that the fast response current limit is not activated. Torque may not be produced, causing a drop due to gravity.

**⚠ CAUTION**

- ⚠ Always perform test operation.
- Stall prevention operation performed during acceleration may increase the acceleration time.
  - Stall prevention operation performed during constant speed may cause sudden speed changes.
  - Stall prevention operation performed during deceleration may increase the deceleration time, increasing the deceleration distance.

**3.17.2 OL signal output timer (Pr. 157 (speed torque position))**

Use this parameter to set whether the overload alarm signal (OL signal) is output immediately or a preset period of time after occurrence of an overload status.

Parameter	Name	Factory Setting	Setting Range	Remarks
157	OL signal output timer	0s	0 to 25s, 9999	9999: No signal output

- V/F control ..... On when stall prevention operation level is exceeded.
- Speed control ..... On when torque limit is activated.
- Torque control ..... On when speed limit is activated.
- Position control ... On when torque limit is activated.

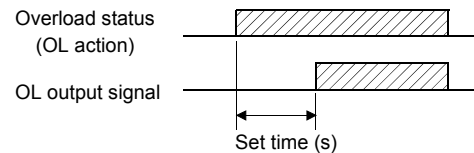

**<Setting>**

Refer to the following table and set the parameter.

Pr. 157 Setting	Description
0	Output immediately.
0.1 to 25	Output after the set time (s) has elapsed.
9999	Overload alarm signal is not output.

**Related parameters**

- OL signal terminal assignment ⇒ Set 3 in any of Pr. 190 to Pr. 192, Pr. 195 (output terminal function selection). (Refer to page 152.)

**Pr.158** ➡ Refer to Pr. 54 (page 97).

## 3.18 Display function 3 (Pr. 160)

### 3.18.1 Extended function display selection (Pr. 160 speed torque position)

Used to display the extended function parameters.

- Refer to page 66 for the extended function parameter list.

Parameter	Name	Factory Setting	Setting Range	Remarks
160	Extended function selection	0	0	Only the simple mode parameters are accessible.
			1	All parameters are accessible.

Pr. 162 to Pr. 165 → Refer to Pr. 57 (page 101).

## 3.19 Initial monitor (Pr. 171)

### 3.19.1 Actual operation hour meter clear (Pr. 171 speed torque position)

You can clear the actual operation hour of the monitoring function.

Parameter	Name	Factory Setting	Setting Range
171	Actual operation hour meter clear	0	0

#### <Setting>

Write "0" in the corresponding parameter to clear the actual operation hour.

#### REMARKS

The actual operation time is the value monitored by setting "23" in Pr. 52.

#### Related parameters

- Pr. 52 "DU/PU main display data selection" (Refer to page 97.)

## 3.20 Terminal assignment functions (Pr. 180 to Pr. 195)

### 3.20.1 Input terminal function selection

(Pr. 180 to Pr. 183, Pr. 187 speed torque position)

Use these parameters to select/change the input terminal functions.

Parameter	Name	Terminal Symbol	Factory-Set Value	Factory-Set Terminal Function	Setting Range	Remarks	
180	DI1 terminal function selection	DI1	0	Low speed operation command (RL)	0 to 3, 5, 8 to 12, 14 to 16, 20, 22 to 28, 42 to 44, 9999	9999: No function	Extended mode
181	DI2 terminal function selection	DI2	1	Middle speed operation command (RM)			
182	DI3 terminal function selection	DI3	2	High speed operation command (RH)			
183	DI4 terminal function selection	DI4	3	Second function/ second motor switchover (RT)			
187	STR terminal function selection	STR	9999	Reverse rotation command (STR)	9999: STR		

**<Setting>**

Refer to the following table and set the parameters.

Setting	Signal Name	Functions		Related Parameters	Response Time
0	RL	Pr. 59 = 0	Low speed operation command	Pr. 4 to Pr. 6, Pr. 24 to Pr. 27, Pr. 232 to Pr. 239	Within 20ms
		Pr. 59 = 1, 2 *	Remote setting (setting clear)		
1	RM	Pr. 59 = 0	Middle speed operation command	Pr. 4 to Pr. 6, Pr. 24 to Pr. 27, Pr. 232 to Pr. 239	
		Pr. 59 = 1, 2, 3 *	Remote setting (deceleration)		
2	RH	Pr. 59 = 0	High speed operation command	Pr. 4 to Pr. 6, Pr. 24 to Pr. 27, Pr. 232 to Pr. 239	
		Pr. 59 = 1, 2, 3*	Remote setting (acceleration)		
3	RT	Second function selection		Pr. 44 to Pr. 50, Pr. 450 to Pr. 457, Pr. 463	
5	JOG	Jog operation selection		Pr. 15, Pr. 16	
8	REX	15-speed selection (combination with three speeds RL, RM, RH)		Pr. 4 to Pr. 6, Pr. 24 to Pr. 27, Pr. 232 to Pr. 239	
9	X9	Third function		Pr. 110, Pr. 111, Pr. 116	
10	X10	FR-HC connection, FR-CV connection (inverter operation enable)		Pr. 30, Pr. 70	Within 2ms
11	X11	FR-HC connection (instantaneous power failure detection) (only when FR-A5NR option is fitted)		Pr. 30, Pr. 70	Within 20ms
12	X12	PU operation external interlock signal		Pr. 79	
14	X14	PID control enable terminal		Pr. 128 to Pr. 134	
15	BRI	Brake sequence opening completion signal		Pr. 278 to Pr. 285	
16	X16	PU/external operation switchover		Pr. 79	
20	X20	S-pattern acceleration/deceleration C switchover		Pr. 29, Pr. 380 to Pr. 383	
22	X22	Orientation command (Caution 4)		Pr. 350 to Pr. 369	
23	LX	Pre-excitation/servo on (Caution 5)		Pr. 802	
24	MRS	Output stop		Pr. 17	
25	STOP	Start self-holding selection		—	
26	MC	Control mode changing		—	
27	TL	Torque limit selection		Pr. 815	
28	X28	Start time tuning		—	
42	X42	Torque bias selection 1		—	
43	X43	Torque bias selection 2		—	
44	X44	P control selection (P/PI control switchover)		—	
9999	STR	Reverse rotation start		STR terminal (Pr. 187) only (Note) DI1 to DI4 functions are made invalid.	—

\* When Pr. 59 = "1, 2, or 3", the functions of the RL, RM, RH and RT signals change as listed above.

**CAUTION**

1. One signal can be assigned to two or more terminals. In this case, turning on any one of the terminals make the signal valid.
2. The speed command priorities are higher in order of jog, multi-speed setting (RH, RM, RL, REX) and PID (X14).
3. Use common terminals to assign multi-speeds (7 speeds) and remote setting. They cannot be set individually.
4. The FR-A5AX (12-bit digital input) is needed to externally input a stop position under orientation control.
5. Made valid under vector control.



**3.20.2 Output terminal function selection**

(Pr. 190 to Pr. 192, Pr. 195 **speed** **torque** **position** )

You can change the functions of the open collector output terminal and contact output terminal.

Parameter	Name	Factory-Set Value	Factory-Set Signal Function	Setting Range	Remarks
190	DO1 terminal function selection	0	RUN (Inverter running)	0 to 8, 10 to 16, 20, 25 to 27, 30 to 37, 39, 40 to 44, 96 to 99, 100 to 108, 110 to 116, 120, 125 to 127, 130 to 137, 139, 140 to 144, 196 to 199, 9999	Extended mode
191	DO2 terminal function selection	1	SU (Up to speed)		
192	DO3 terminal function selection	2	IPF (Instantaneous power failure/ undervoltage)		
195	ABC terminal function selection	99	A, B, C (Alarm output)		

**<Setting>**

Refer to the following table and set the parameters.

Setting		Signal Name	Function	Operation	Related Parameters	Response Time
Positive logic	Negative logic					
0	100	RUN	Inverter running	This signal is output during operation when the inverter output speed rises to or above the starting speed. During DC injection brake, 0 speed control or servo lock, this signal is not output. However, LX is output as ON under position control.	—	Within 20ms
1	101	SU	Up to speed	Refer to Pr. 41 "up-to-speed sensitivity" (page 95). (Caution 1)	—	—
2	102	IPF	Instantaneous power failure or undervoltage	Output at occurrence of an instantaneous power failure or undervoltage.	—	—
3	103	OL	Overload alarm	Output when torque or speed limit is activated. For V/F control, this signal is output while the stall prevention function is activated.	Pr. 22, Pr. 806, Pr. 807, Pr. 812 to Pr. 817	—
4	104	FU	Output speed detection	Refer to Pr. 42, Pr. 43, Pr. 50 and Pr. 116 (speed detection) (page 95).	—	Within 20ms
5	105	FU2	Second output speed detection			
6	106	FU3	Third output speed detection			
7	107	RBP	Regenerative brake prealarm	Output when 85% of the regenerative brake duty set in Pr. 70 is reached.	Pr. 70	—
8	108	THP	Electronic thermal relay function prealarm	Output when the electronic thermal relay function cumulative value reaches 85% of the preset level.	Pr. 9	—
10	110	PU	PU operation mode	Output when the PU operation mode is selected.	—	Within 20ms
11	111	RY	Inverter operation ready	Output when the inverter can be started by switching the start signal on or while it is running.		
12	112	Y12	Output current detection	Refer to Pr. 150 and Pr. 151 (output current detection).	Pr. 150, Pr. 151	—
13	113	Y13	Zero current detection	Refer to Pr. 152 and Pr. 153 (zero current detection).	Pr. 152, Pr. 153	—
14	114	FDN	PID lower limit	Refer to Pr. 128 to Pr. 134 (PID control).	Pr. 128 to Pr. 134	Within 20ms
15	115	FUP	PID upper limit			
16	116	RL	PID forward-reverse rotation output			
20	120	BOF	Brake opening request	Refer to Pr. 278 to Pr. 285 (brake sequence function).	Pr. 278 to Pr. 285	—
25	125	FAN	Fan fault output	Output at the time of a fan fault.	Pr. 244	—
26	126	FIN	Fin overheat prealarm	Output when the heatsink temperature reaches about 85% of the fin overheat protection activating temperature.	—	—
27	127	ORA	Orientation in-position	When orientation is valid (Refer to page 159)	—	—

Setting		Signal Name	Function	Operation	Related Parameters	Response Time
Positive logic	Negative logic					
30	130	Y30	Forward rotation output	Under vector control ON: forward rotation OFF: others	—	Within 20ms
31	131	Y31	Reverse rotation output	Under vector control ON: reverse rotation OFF: others		
32	132	Y32	Regenerative status output	Under vector control ON: regeneration OFF: others (including stop and pre-excitation)		
33	133	RY2	Operation ready 2	Output on completion of pre-excitation. Turned on at an output start when pre-excitation is not made.	Pr. 802	—
34	134	LS	Low speed output	Output when the speed falls to or below any preset low speed.	Pr. 865	
35	135	TU	Torque detection	Output when the motor torque rises above the predetermined value.	Pr. 864	
36	136	Y36	In-position	Output when positioning is completed under position control.	—	Within 20ms
37	137	MT	Maintenance timer output	When Pr. 891 ≥ Pr. 890, the MT output signal turns on and the warning indication MT appears.	Pr. 890, Pr. 891	—
39	139	Y39	Start time tuning completion	Output on completion of start time tuning.		
40	140	Y40	Trace status	Refer to the instruction manual of the trace option.	—	
41	141	FB	Speed detection	Output when the inverter output speed rises to or above the preset speed. Refer to Pr. 42, Pr.43, Pr. 50, and Pr. 116 (speed detection) (page 95).	—	Within 20ms
42	142	FB2	Second speed detection			
43	143	FB3	Third speed detection			
44	144	RUN2	Inverter running 2	<ul style="list-style-type: none"> <li>• Output during forward rotation or the reverse rotation signal is on.</li> <li>• Output at deceleration even during forward rotation or the reverse rotation signal is off. (Does not output during pre-excitation LX is on.)</li> <li>• Output during the orientation command signal (X22) is on.</li> <li>• Switched on when the servo is on (LX-on) under position control. (Switched off when the servo is off. (LX-off))</li> </ul>	—	—
96	196	REM	Remote output	You can use the on/off of signals instead of the remote output function of the PLC.	Pr. 495, Pr. 496, Pr. 497	
97	197	ER	Minor fault output 2	Output when the inverter protective function is activated to stop the output (major fault) if "0" is set in Pr. 875 (factory setting). Output when the inverter's protective function is activated to start deceleration if "1" is set in Pr. 875 and an OHT/THM/PTC error occurs. Output when the inverter stops the output if the other protective functions are activated.	Pr. 875	Within 20ms
98	198	LF	Minor fault output	Output when a minor fault (fan fault or communication error alarm) occurs.	Pr. 121, Pr. 244	
99	199	ABC	Alarm output	Output when the inverter's protective function is activated to stop the output (major fault).	—	
9999		—	No function	—	—	—

0 to 99: Positive logic

100 to 199: Negative logic

**CAUTION**

1. Note that when the speed setting is varied using an analog signal or / of the control panel, the output of the SU (up to speed) signal may alternate on and off depending on that varying speed and the timing of the varying speed due to acceleration/deceleration time setting.  
(The output will not alternate on and off when the acceleration/deceleration time setting is "0s".)
2. The same function may be set to more than one terminal.
3. Pr. 190 to Pr. 192 and Pr. 195 do not function if the values set are other than the above.

**Pr.232 to Pr.239** ➡ Refer to Pr. 4 (page 77).

**Pr.240** ➡ Refer to Pr. 72 (page 112).

## 3.21 Auxiliary function (Pr. 244)

### 3.21.1 Cooling fan operation selection (Pr. 244 speed torque position)

You can control the operation of the cooling fan built in the inverter.

Parameter	Name	Factory Setting	Setting Range	Remarks
244	Cooling fan operation selection	0	0, 1	Extended mode

#### <Setting>

Setting	Description
0	Operated with power on (independently of whether the inverter is running or at a stop).
1	Cooling fan on-off control valid (The cooling fan is always on while the inverter is running. During a stop, the inverter status is monitored and the fan switches on-off according to temperature.)

#### REMARKS

In either of the following cases, fan operation is regarded as faulty, [FN] is shown on the control panel, and the fan fault (FAN) and minor fault (LF) signals are output. Use Pr. 190 to Pr. 192, Pr. 195 (output terminal function selection) to allocate the terminals used to output the FAN and LF signals.

- Pr. 244 = "0"  
When the fan comes to a stop with power on.
- Pr. 244 = "1"  
When the fan comes to a stop during the fan ON command while the inverter is running.

#### CAUTION

Changing the terminal function using any of Pr. 190 to 192 and Pr. 195 may affect the other functions. Confirm the functions of the corresponding terminals before making setting.

## 3.22 Stop selection function (Pr. 250)

### 3.22.1 Stop selection (Pr. 250 speed torque)

Used to select the stopping method (deceleration to a stop or coasting) when the start signal (STF/STR) turns off.

Parameter	Name	Factory Setting	Setting Range	Remarks
250	Stop selection	9999	0 to 100s, 9999	Extended mode

**(1) Pr. 250 = "9999"**

When the start signal turns off, the motor is decelerated to a stop.

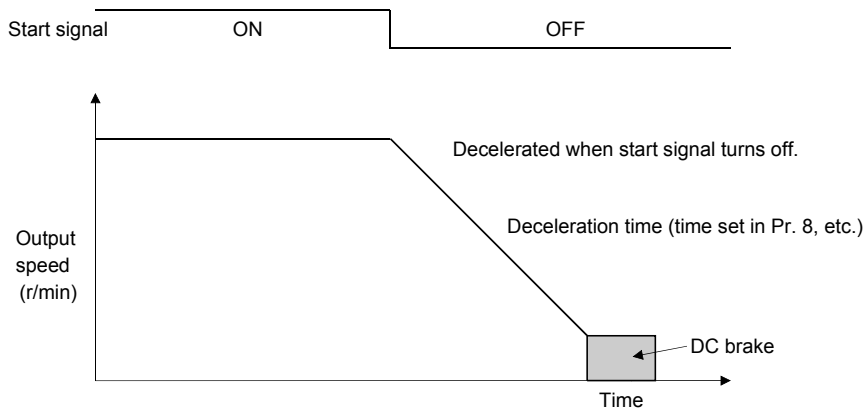

**(2) Pr. 250 = other than "9999" (Output is shut off after preset time)**

The output is shut off when the time set in Pr. 250 has elapsed after the start signal had turned off. The motor coasts to a stop.

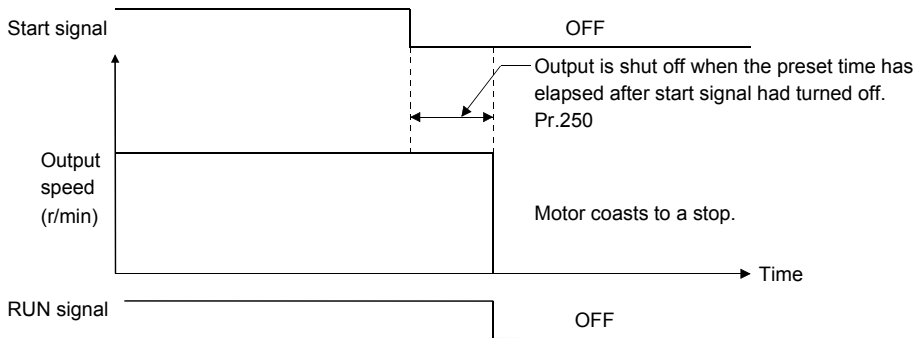

**CAUTION**

1. The RUN signal turns off when the output stops.
2. When the start signal is turned on again during motor coasting, the motor starts at 0Hz.
3. The output speed becomes the speed limit value during torque control.

**3.23 Operation selection function (Pr. 251)**

**3.23.1 Output phase failure protection selection (Pr. 251 speed torque position )**

You can disable the output phase failure protection (E.LF) function that will stop the inverter output if any of the three phases (U, V, W) on the inverter output side (load side) opens.

Parameter	Name	Setting Range	Minimum Setting Increments	Factory Setting	Description	Remarks
251	Output phase failure protection selection	0, 1	1	1	0: Without output phase failure protection 1: With output phase failure protection	Extended mode

### 3.24 Additional function 2 (Pr. 252, Pr. 253)

#### 3.24.1 Override bias, gain (Pr. 252, Pr. 253 speed torque )

When override is selected in Pr. 73 "speed setting signal", the override range can be extended from 50%-150% to 0%-200% and set as desired.

Parameter	Name	Setting Range	Minimum Setting Increments	Factory Setting	Remarks
252	Override bias	0 to 200%	0.1%	50%	Extended mode
253	Override gain	0 to 200%	0.1%	150%	

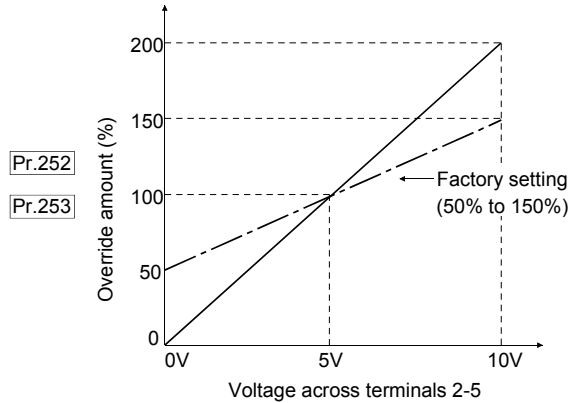

#### Related parameters

- ⇒ Pr. 73 "speed setting signal" (Refer to page 113.)

### 3.25 Power failure stop functions (Pr. 261 to Pr. 266)

#### 3.25.1 Power-failure deceleration stop function (Pr. 261 to Pr. 266 speed torque )

When a power failure or undervoltage occurs, the inverter can be decelerated to a stop.

- Remove the jumpers from across terminals R-R1 and S-S1, and connect terminal R1 to terminal P and terminal S1 to terminal N.

Parameter	Name	Factory Setting	Setting Range	Remarks
261	Power failure stop selection	0	0, 1	Extended mode
262	Subtracted speed at deceleration start	90r/min	0 to 600r/min	
263	Subtraction starting speed	1500r/min	0 to 3600r/min, 9999	
264	Power-failure deceleration time 1	5s	0 to 3600/0 to 360s	
265	Power-failure deceleration time 2	9999	0 to 3600/0 to 360s, 9999	
266	Power-failure deceleration time switchover speed	1500r/min	0 to 3600r/min	

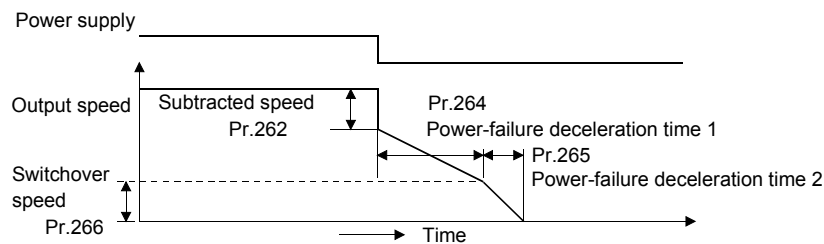

**<Setting>**

Parameter	Setting	Description
261	0	Coasting to stop When undervoltage or power failure occurs, the inverter output is shut off.
	1	When undervoltage or power failure occurs, the inverter is decelerated to a stop.
262	0 to 600r/min	Normally, operation can be performed with the factory setting unchanged, but the speed can be adjusted within the range 0 to 600r/min according to the load specifications (moment of inertia, torque).
263	0 to 3600r/min	If the output speed at occurrence of undervoltage or power failure is equal to or greater than the speed set in Pr. 263, deceleration starts at the value found by subtracting the speed set in Pr. 262 from the output speed at that time. If the output speed at occurrence of undervoltage or power failure is less than the speed set in Pr. 263, the inverter is decelerated to a stop, starting at the output speed at that time.
	9999	The inverter is decelerated to a stop, starting at the value found by subtracting the speed set in Pr. 262 from the output speed at occurrence of undervoltage or power failure.
264	Pr. 21 = 0	Set a deceleration slope down to the speed set in Pr. 266. Set the slope in terms of time required for deceleration from the speed set in Pr. 20 to 0r/min.
	Pr. 21 = 1	
265	Pr. 21 = 0	Set a deceleration slope below the speed set in Pr. 266. Set the slope in terms of time required for deceleration from the speed set in Pr. 20 to 0r/min.
	Pr. 21 = 1	
	9999	Same slope as in Pr. 264.
266	0 to 3600r/min	Set the speed at which the deceleration slope is switched from the Pr. 264 setting to the Pr. 265 setting.

**CAUTION**

1. This function is invalid when the automatic restart after instantaneous power failure function is activated.
2. If the calculation result of the output speed - set speed of Pr. 262 is negative at occurrence of undervoltage or power failure, it is regarded as 0r/min.
3. The power failure stop function is not activated if a power failure occurs during a stop or error.
4. If power is restored during deceleration, the inverter is kept decelerated to a stop. To restart, turn off the start signal once, then turn it on again.
5. This function is not activated when the high power factor converter or power regeneration common converter is used (Pr. 30 = 2).

**⚠ CAUTION**

⚠ If power-failure deceleration operation is set, some loads may cause the inverter to trip and the motor to coast.  
The motor will coast if enough regenerative energy is not given from the motor.

**Related parameters**

- Pr. 12 "DC injection brake voltage" (Refer to page 82.)
- Pr. 20 "acceleration/deceleration reference speed", Pr. 21 "acceleration/deceleration time increments" (Refer to page 78.)

**Pr.278 to Pr.285 ➡ Refer to Pr.60 (page 106).**

### 3.26 Droop (Pr. 286 to Pr. 288)

#### 3.26.1 Droop control (Pr. 286 to Pr. 288 speed )

This function is designed to balance the load in proportion to the load torque to provide the speed drooping characteristic.

This function is effective for balancing the load when using multiple inverters

- The speed command is varied according to the magnitude of the motor load (load meter of the inverter). The drooping amount at the rated torque is set by the droop gain as a percentage using the rated speed as a reference.

$$\text{Droop compensation speed} = \frac{\text{Amount of torque current after filtering}}{100\% \text{ torque amount current}} \times \frac{\text{Rated speed} \times \text{droop gain}}{100}$$

- Droop control is made valid when Pr. 286 is other than "0".

Parameter	Name	Factory Setting	Setting Range	Remarks
286	Droop gain	0%	0 to 100%	The drooping amount at the rated torque is set by the droop gain as a percentage using the rated speed as a reference. When the setting value is "0", the function will be invalid.
287	Droop filter time constant	0.3s	0.00 to 1.00s	Set the time constant of the primary delay filter applied to the torque current.
288	Droop function activation selection	0	0	Droop control is not exercised during acceleration/deceleration.
			1	Droop control is always exercised during operation. (with zero limit)
			2	Droop control is always exercised during operation (without zero limit)

#### ● Speed limiter after droop compensation

Pr. 288 setting	Description
0	Droop control is not exercised during acceleration/deceleration. Note that the speed command after droop is stopped at 0r/min if the speed command after droop is negative.
1	Droop control is always exercised during operation. Note that, during vector control with encoder, the speed command after droop is stopped at 0r/min if the speed command after droop is negative.
2	Droop control is always exercised during operation. Note that the speed command after droop is not stopped at 0r/min even if the speed command after droop is negative.

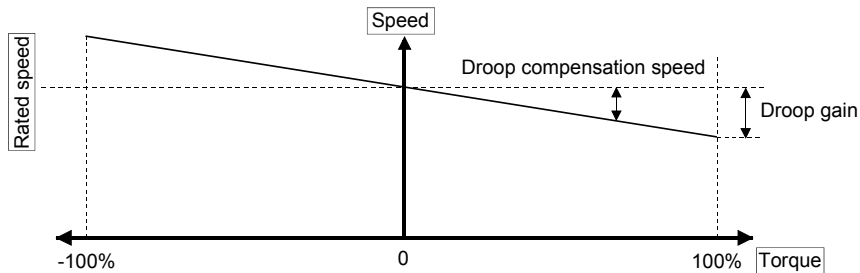

Pr. 342 Refer to Pr. 117 (page 128).

### 3.27 Orientation (Pr. 350 to Pr. 362, Pr. 393 to Pr. 399)

#### 3.27.1 Orientation control (Pr. 350, Pr. 351, Pr. 356, Pr. 357, Pr. 360 to Pr. 362, Pr. 393, Pr. 396 to Pr. 399 speed )

Orientation is a function that stops a motor shaft at a position set by parameter using the motor built-in position detector (encoder). Install the option (FR-V5AM or FR-A5AP) on the inverter to perform stop position command control with a position detector (encoder) fitted to the machine. Refer to the instruction manual of the option for details.

Pr. 350 "stop position command selection" is factory-set to "9999" to make the orientation control function invalid.

Parameter No.	Name	Setting Range	Factory Setting	Remarks
350	Stop position command selection	0, 1, 2, 3, 9999	9999	Extended mode
351	Orientation switchover speed	0 to 1000r/min	200r/min	
356	Internal stop position command	0 to 16383	0	
357	Orientation in-position zone	0 to 8192	11	
360	External position command selection	0, 1, 2 to 127	0	
361	Position shift	0 to 16383	0	
362	Orientation position loop gain	0.1 to 100	10	
393	Orientation selection	1, 2, 10, 11, 12	0	
396	Orientation speed gain (P term)	0 to 1000%	60%	
397	Orientation speed integral time	0 to 20.0s	0.333s	
398	Orientation speed gain (D term)	0 to 100.0%	1%	
399	Orientation deceleration ratio	0 to 1000	20	

#### REMARKS

Check the Pr. 851 and Pr. 852 settings. (Refer to the Instruction Manual (basic).)

<Settings>

If the orientation command signal (X22) is turned on during operation after the various parameters have been set, the speed will decelerate to the "orientation switchover speed". After the "orientation stop distance" is calculated, the speed will further decelerate, and the "orientation state" (servo lock) will be entered. The "orientation complete signal" (ORA) will be output when the "orientation complete width" is entered.

#### (1) Setting I/O signals

Input	Orientation command	X22 signal	Orientation control is valid with the signal on. Set "22" in any of Pr. 180 to Pr.183 or Pr. 187 (input terminal function selection). (Refer to page 150.)
Output	Orientation complete signal	ORA signal	Switched low if the orientation has stopped within the in-position zone while the start and orientation signals are input. Open collector output Permissible load 24VDC, 0.1A Set 27 in any of Pr.190 to Pr. 192 or Pr. 195 (output terminal function selection). (Refer to page 152.)



**(2) Selecting stop position command (Pr. 350 "stop position command selection")**

Select either the internal stop position command (Pr. 356) or the external stop position command (6/12/16-bit data).

Pr. 350 Setting	Type of Command
0	Internal stop position command (Pr. 356:0 to 16383)
1	External stop position command (FR-V5AX) 6-bit data
2	External stop position command (FR-A5AX) 12-bit data
3	External stop position command (FR-V5AH) 16-bit data
9999 (factory setting)	Orientation control invalid

**(1) Internal stop position command (Pr. 350 = "0")**

The value set in Pr. 356 is the stop position.

When the number of encoder pulses is 1024p/r, one revolution of the encoder (360°) is divided into 4096 positions, i.e. 360°/4096 pulses = 0.0879°/pulses per address, as shown on the right. The stop positions (addresses) are indicated in parentheses.

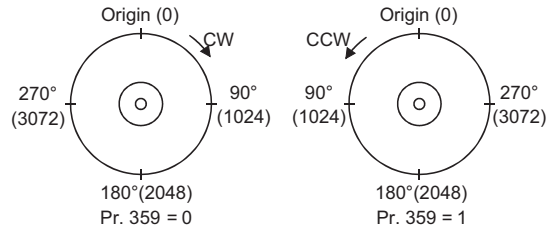

**(2)-1 External stop position command (Pr. 350 = "1")**

(Pr. 360 "external position command selection" (factory setting: 0))

Mount the option FR-V5AX and set a stop position using 6-bit data (binary input).

- The value set in Pr. 360 "external position command selection" should be the number of stop positions less 1.

Pr. 360 Setting	Description
0	External position command is made invalid (multi-function input with the FR-V5AX)
1	Set 64 stop positions at regular intervals
2 to 127	Set the stop position command dividing up to 128 stop positions at regular intervals. If the external stop command entered is greater than the setting, the stop positions are the same as those in the maximum external stop command value. Note that the stop command greater than the 64 stop positions can not be entered if the number of stop positions are 65 to 128. <Example> When the number of stop positions is 20 (divided at intervals of 18°), 20 - 1 = 19. Hence, set "19".

<p><b>[Example 1]</b> 4 stop positions</p> <p>Pr. 360 = "3"</p>	<p><b>[Example 2]</b> 8 stop positions</p> <p>Pr. 360 = "7"</p>	<p><b>[Example 3]</b> 120 stop positions</p> <p>The external stop command can not be entered.</p> <p>Pr. 360 = "119"</p>
---	---	--

**(2)-2 External stop position command (Pr. 350 = "2")**

Mount the option FR-A5AX and set a stop position using 12-bit data (binary input).

- The value set in Pr. 360 "external position command selection" should be the number of stop positions less 1.

Pr. 360 Setting	Description
0	External position command is made invalid (speed command with the FR-A5AX)
1	Set 4096 stop positions at regular intervals
2 to 127	Set the stop position command dividing up to 128 stop positions at regular intervals. If the external stop command entered is greater than the setting, the stop positions are the same as those in the maximum external stop command value. <Example> When the number of stop positions is 90 (divided at intervals of 4°), 90 - 1 = 89. Hence, set "89".

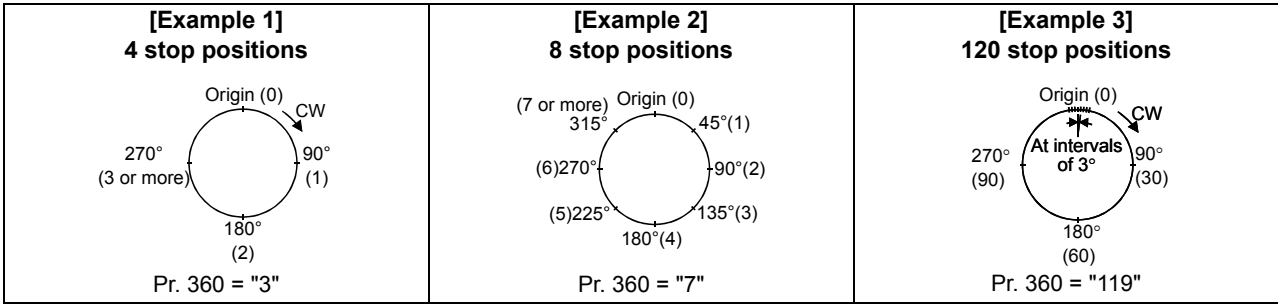

**CAUTION**

- Values in parentheses indicate binary data entered from the terminals. If the position pulse monitoring (Pr. 52 "DU/PU main display screen data selection" = 19) is selected, the data monitored is not the number of stop positions but is 0 to 4095 pulses.
- When any of "1 to 127" is set in Pr. 360, parameters (Pr. 300 to Pr. 305) of the FR-A5AX are made invalid. (Parameters are valid when Pr. 360 = "0".)
- Terminal DY (Data read timing input signal) is made invalid. (The position data is downloaded at the start of orientation.)
- When the option is not fitted or Pr. 360 = "0", the stop position is 0 even if the external stop position command is selected with the Pr. 350 setting.

(2)-3 External stop position command (Pr. 350 = "3")

Mount the option FR-V5AH and set a stop position using 16-bit data (binary input).

- The value set in Pr. 360 "external position command selection" should be the number of stop positions less 1.

Pr. 360 Setting	Description
0	External position command is made invalid (speed command or torque command with the FR-V5AH)
1	Set 65536 stop positions at regular intervals
2 to 127	Set the stop position command dividing up to 128 stop positions at regular intervals. If the external stop command entered is greater than the setting, the stop positions are the same as those in the maximum external stop command value. <Example> When the number of stop positions is 90 (divided at intervals of 4°), 90 - 1 = 89. Hence, set "89".

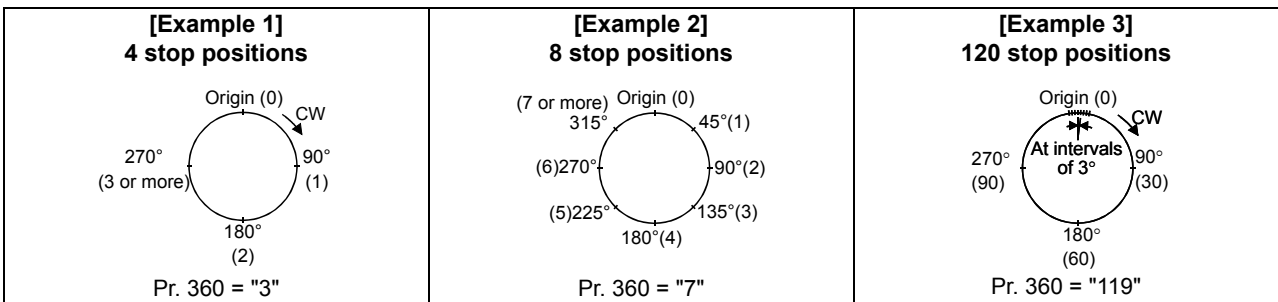

**CAUTION**

- Values in parentheses indicate binary data entered from the input terminals. If the position pulse monitoring (Pr. 52 "DU/PU main display screen data selection" = 19) is selected, the data monitored is not the number of stop positions but is 0 to 65535 pulses.
- When any of "1 to 127" is set in Pr. 360, parameters (Pr. 300 to Pr. 305) of the FR-V5AH are made invalid. (Parameters are valid when Pr. 360 = "0".)
- Terminal DY (Data read timing input signal) is made invalid. (The position data is downloaded at the start of orientation.)
- When the option is not fitted or Pr. 360 = "0", the stop position is 0 even if the external stop position command is selected with the Pr. 350 setting.

**(3) Setting the rotation direction (Pr. 393 "orientation selection")**

Pr. 393 setting	Rotation Direction	Type	Remarks
0 (factory setting)	Pre-orientation	Motor end orientation	Orientation is executed from the current rotation direction.
1	Forward rotation orientation		Orientation is executed from the forward rotation direction. (If the motor is running in reverse, orientation is executed from the forward rotation direction after deceleration.)
2	Reverse rotation orientation		Orientation is executed from the reverse rotation direction. (If the motor is running in forward, orientation is executed from the reverse rotation direction after deceleration.)
10	Pre-orientation	Machine end orientation (when the FR-V5AM or FR-A5AP is used)	Refer to the instruction manual of the option for details.
11	Forward rotation orientation		
12	Reverse rotation orientation		

(1) Orientation from the current rotation direction

- When the orientation command (terminal X22) is input, the motor speed will decelerate from the running speed to Pr. 351 "orientation switchover speed". At the same time, the orientation stop position command will be read in. (The stop position command is determined by the settings of Pr. 350 and Pr. 360. Refer to the diagram on the right.)
- When the orientation switchover speed is reached, the encoder Z phase pulse will be confirmed, and the mode will change from speed control to position control (orientation position loop gain parameter (Pr. 362)).
- When the control is changed, the distance to the orientation stop position will be calculated. The motor will decelerate and stop with a set deceleration pattern (Pr. 399), and the orientation (servo lock) state will be entered.
- When entered in the Pr. 357 orientation in-position zone, the orientation complete signal (terminal ORA) will be output.
- The zero point position (origin) can be moved using position shift (Pr. 361).

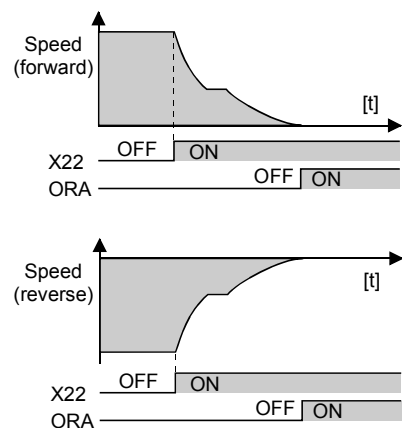

<b>⚠ WARNING</b>	
⚠	<b>If the orientation command (terminal X22) is turned off while the start signal is input, the motor will accelerate toward the speed of the current speed command. Thus, to stop, turn the forward rotation (reverse rotation) signal off.</b>

(2) Orientation from the forward rotation direction

This method is used to improve the stopping precision and maintain the mechanical precision when the backlash is large. If the motor is running in the forward rotation direction, it will orientation stop with the same method as "orientation from the current rotation direction". If the motor is running in reverse, it will decelerate, the rotation direction will be changed to forward run, and then orientation stop will be executed.

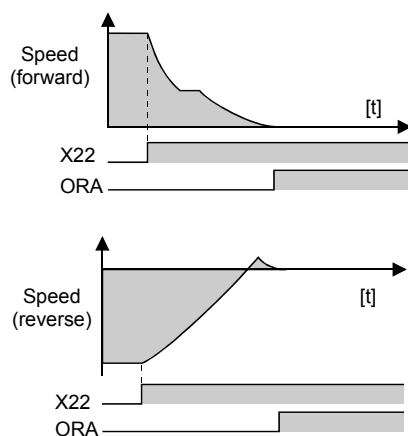

(3) Orientation from the reverse rotation direction

If the motor is running in the reverse rotation direction, it will orientation stop with the same method as "orientation from the current rotation direction".  
 If the motor is running in forward, it will decelerate, the rotation direction will be changed to reverse run, and then orientation stop will be executed.

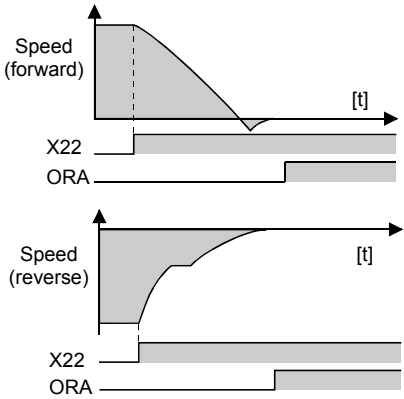

**CAUTION**

1. The encoder should be coupled with the motor shaft or the spindle oriented with a speed ratio of 1 to 1 without any mechanical looseness.
2. To ensure correct positioning, the encoder must be set in the proper rotation direction and the A and B phases connected correctly.
3. The orientation may not be completed if the pulse signals are not received from the encoder during orientation due to a break in the cable or the like.
4. To terminate orientation, the start signal (STF or STR) must be first switched off and the orientation signal (X22) must be switched off. As soon as this orientation signal is switched off, orientation control ends.
5. For orientation control, set correct values in Pr. 350 "stop position command selection" and Pr. 360 "external position command selection"  
 If the values set are incorrect, proper orientation control will not be performed.
6. When orientation control is exercised, PID control is invalid.

**REMARKS**

If "E.ECT" (no encoder signal) is displayed causing the inverter to trip when the orient signal (X22) is ON, check for the encoder signal loss of the Z phase of the encoder.

- Pr. 357 "orientation in-position zone" (factory setting:11)
- The positioning width for orientation stop can be set.  
 The factory setting of Pr. 357 is "11". To change the  $\Delta\theta$  value, finely adjust with  $\pm 10$  increments, and make fine adjustment.
- If the position detection value from the encoder enters  $\pm\Delta\theta$  during orientation stop, the orientation complete signal (ORA) will be output.

Example of operation

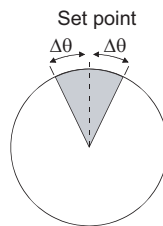

$$\Delta\theta = \frac{360^\circ}{\text{Pr. 851 number of encoder pulses} \times 4} \times \text{Pr. 357}$$

**CAUTION**

This setting is used to judge the ON/OFF of the orientation complete signal, and does not determine the orientation stop precision.

**(4) Fine adjustment of the orientation stop position (Pr. 361 "position shift" (factory setting: 0))**

The orientation stop position will deviate by the value set x 360° / Pr. 851 "number of encoder pulses" x4.  
 Finely adjust the position by changing this setting value in 10 increments.  
 The orientation stop position will differ according to the direction that the encoder is installed in.  
 (Refer to the drawings below.)

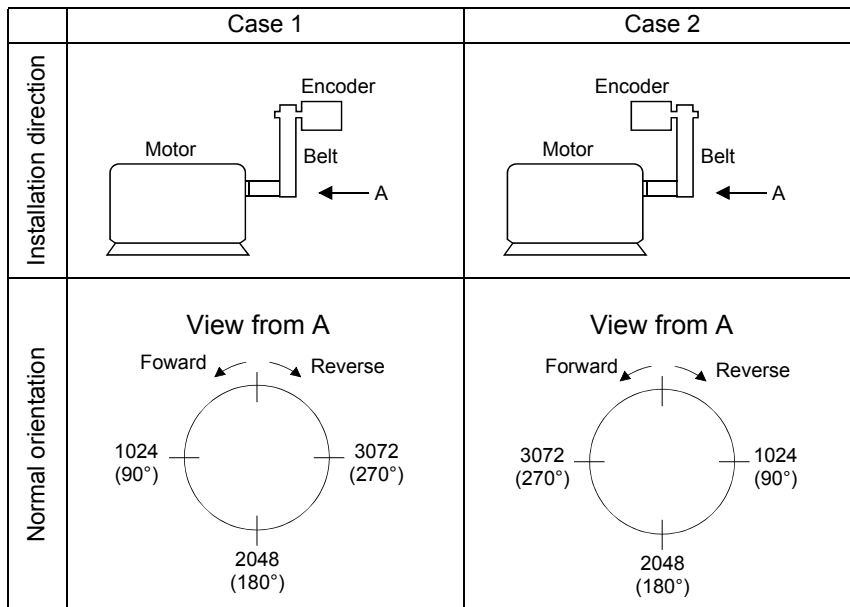

**(5) Adjustment of the servo rigidity**

- Pr. 396 "orientation speed gain (P term)" (factory setting: 60)
  - Pr. 397 "orientation speed integral time" (factory setting: 0.333)
  - Pr. 398 "orientation speed gain (D term)" (factory setting: 1)
  - Pr. 362 "orientation position loop gain" (factory setting: 10)
- To increase the servo rigidity\*1 during orientation stop in Pr. 396 or Pr. 397, adjust with the following procedures.
- 1) Increase the Pr. 362 "orientation position loop gain" value to the extent that rocking does not occur during orientation stop.
  - 2) Increase Pr. 396 and Pr. 397 at the same rate.  
 Generally adjust Pr. 396 in the range from 10 to 100, and Pr. 397 from 0.1 to 1.0s.  
 (Note that these do not need to be set to the same rate.)  
 <Example>  
 When the Pr. 396 value is multiplied by 1.2, divide the Pr. 397 value by 1.2.  
 If vibration occurs during orientation stop, the scale cannot be raised any higher.
  - 3) Pr. 398 is the lag/advance compensation gain.\*2  
 The limit cycle can be prevented by increasing the value, and the running can be stopped stably. However, the torque in regard to the position deviation will drop, and the motor will stop with deviation.

**POINT**

Application of lag/advance control and PI control  
 PI control can be applied by setting Pr. 398 to 0. Normally, the lag/advance control is selected. Use PI control in the following cases.  
 When using a machine with a high spindle stationary friction torque and requires a stopping position precision.

**REMARKS**

\*1. Servo rigidity: This is the response when a position control loop is configured.  
 When the servo rigidity is raised, the holding force will increase, the running will stabilize, but vibration will occur easily.  
 When the servo rigidity is lowered, the holding force will drop, and the setting time will increase.  
 \*2. Limit cycle\*: This is a phenomenon that generates ± continuous vibration centering on the target position.  
 \*3. Rocking: Movement in which return occurs if the stopping position is exceeded.

- Pr. 399 "orientation deceleration ratio" (factory setting: 20)
- Make adjustments as shown below according to the orientation status.  
(Refer to the Pr. 396 and Pr. 397 details also.)  
Generally adjust Pr. 362 in the range from 5 to 20 and Pr. 399 from 5 to 50.

Phenomenon	Adjustment Procedure			
	Pr. 396	Pr. 397	Pr. 362	Pr. 399
Rocking occurs during stopping	3) ↗	3) ↗	2) ↘	1) ↘
The orientation time is long	→	→	2) ↗	1) ↗
Hunting occurs when stopping	2) ↘	2) ↗	1) ↘	→
The servo rigidity during stopping is low	1) ↗	1) ↘	2) ↗	→

**REMARKS**

- ↗ :Increase the parameter setting value.  
→ :Do not change the parameter setting value.  
↘ :Decrease the parameter setting value.
- The numbers 1) 2) and 3) in the table show the order of priority for changing the parameters setting value.

**CAUTION**

If orientation stop is not possible and the excessive position error alarm occurs, or if the motor does forward/reverse reciprocation operation , the parameter setting value for the orientation detector installation direction may be incorrect. Review Pr. 393 "orientation selection" (Refer to page 162.) and Pr. 852 "encoder rotation direction" (Refer to the Instruction Manual (basic).).

- Pr. 351 "orientation switchover speed" (factory setting: 200)
- Set the speed when switching between the speed control mode and the position control mode under orientation operation. Decreasing the set speed enables stable orientation stop. Note that the orientation time will increase.

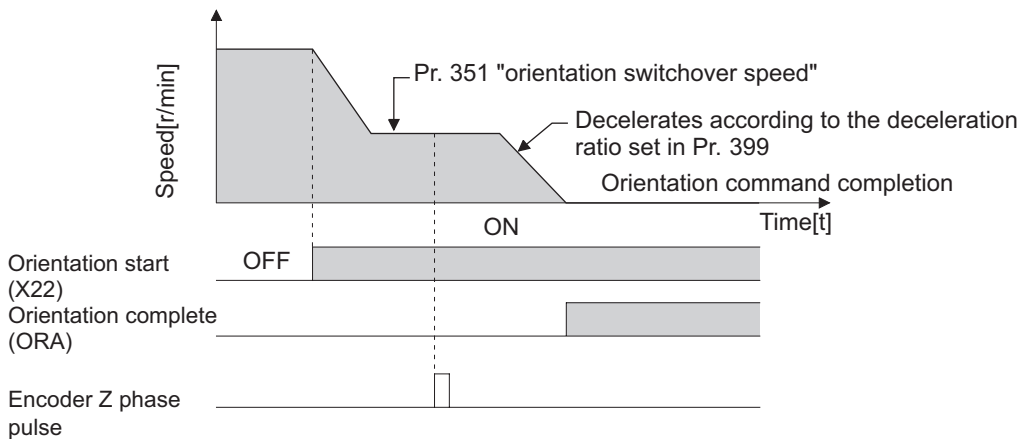

**REMARKS**

When " 19" is set in Pr. 52 "DU/PU main display data selection", position pulse monitor is displayed instead of PU output voltage monitor.

### 3.28 Control system function (Pr. 374)

#### 3.28.1 Overspeed detection (Pr. 374 speed torque position)

- Excess of the motor speed over the overspeed detection level results in E.OS, stopping the output. This function is enabled only during speed control, torque control or position control.

Parameter	Name	Setting Range	Factory Setting	Remarks
374	Overspeed detection level	0 to 4200r/min	3450r/min	Extended mode

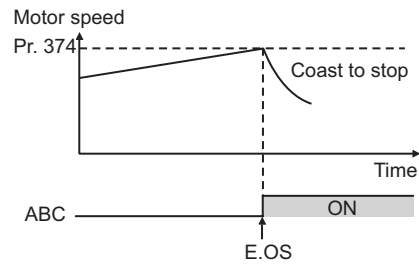

Pr. 380 to Pr. 383 ➡ Refer to Pr. 29 (page 89).

Pr. 393, Pr. 396 to Pr. 399 ➡ Refer to Pr. 350 (page 159).

### 3.29 Position control (Pr. 419 to Pr. 430, Pr. 464 to Pr. 494)

#### 3.29.1 Position control (Pr. 419 to Pr. 430, Pr. 464 to Pr. 494 position )

Parameter	Name	Setting Range	Factory Setting	Remarks
419	Position command source selection	0, 1	0	Refer to page 55 for details of position control.
420	Command pulse scaling factor numerator	0 to 32767	1	
421	Command pulse scaling factor denominator	0 to 32767	1	
422	Position loop gain	0 to 150s <sup>-1</sup>	25s <sup>-1</sup>	
423	Position feed forward gain	0 to 100%	0%	
424	Position command acceleration/deceleration time constant	0 to 50s	0s	
425	Position feed forward command filter	0 to 5s	0s	
426	In-position width	0 to 32767 pulses	100 pulses	
427	Excessive level error	0 to 400K, 9999	40K	
430	Pulse monitor selection	0 to 5, 9999	9999	
464	Digital position control sudden stop deceleration time	0 to 360.0s	0	

Parameter	Name	Setting Range	Factory Setting	Selection Method				Positioning Speed
				REX	RH	RM	RL	
465	First position feed amount lower 4 digits	0 to 9999	0	OFF	ON	OFF	OFF	High speed, Pr. 4
466	First position feed amount upper 4 digits			OFF	OFF	ON	OFF	Middle speed, Pr. 5
467	Second position feed amount lower 4 digits			OFF	OFF	OFF	ON	Low speed, Pr. 6
468	Second position feed amount upper 4 digits			OFF	OFF	ON	ON	Speed 4, Pr. 24
469	Third position feed amount lower 4 digits			OFF	ON	OFF	ON	Speed 5, Pr. 25
470	Third position feed amount upper 4 digits			OFF	ON	ON	OFF	Speed 6, Pr. 26
471	Fourth position feed amount lower 4 digits			OFF	ON	ON	ON	Speed 7, Pr. 27
472	Fourth position feed amount upper 4 digits			ON	OFF	OFF	OFF	Speed 8, Pr. 232
473	Fifth position feed amount lower 4 digits			ON	OFF	OFF	ON	Speed 9, Pr. 233
474	Fifth position feed amount upper 4 digits			ON	OFF	ON	OFF	Speed 10, Pr. 234
475	Sixth position feed amount lower 4 digits			ON	OFF	ON	ON	Speed 11, Pr. 235
476	Sixth position feed amount upper 4 digits			ON	ON	OFF	OFF	Speed 12, Pr. 236
477	Seventh position feed amount lower 4 digits			ON	ON	OFF	ON	Speed 13, Pr. 237
478	Seventh position feed amount upper 4 digits			ON	ON	ON	OFF	Speed 14, Pr. 238
479	Eighth position feed amount lower 4 digits			ON	ON	ON	ON	Speed 15, Pr. 239
480	Eighth position feed amount upper 4 digits							
481	Ninth position feed amount lower 4 digits							
482	Ninth position feed amount upper 4 digits							
483	Tenth position feed amount lower 4 digits							
484	Tenth position feed amount upper 4 digits							
485	Eleventh position feed amount lower 4 digits							
486	Eleventh position feed amount upper 4 digits							
487	Twelfth position feed amount lower 4 digits							
488	Twelfth position feed amount upper 4 digits							
489	Thirteenth position feed amount lower 4 digits							
490	Thirteenth position feed amount upper 4 digits							
491	Fourteenth position feed amount lower 4 digits							
492	Fourteenth position feed amount upper 4 digits							
493	Fifteenth position feed amount lower 4 digits							
494	Fifteenth position feed amount upper 4 digits							

Pr. 450 ➡ Refer to Pr. 71 (page 111).

Pr. 451 ➡ Refer to Pr. 800 (page 169).

Pr. 452 ➡ Refer to Pr. 9 (page 80).

Pr. 453, Pr. 454 ➡ Refer to page 38.

Pr. 464 to Pr. 494 ➡ Refer to page 55.



### 3.30 Remote output (Pr. 495 to Pr.497)

#### 3.30.1 Remote output function (Pr. 495 to Pr.497 speed torque position )

You can utilize the on/off of the inverter's output signals instead of the remote output function of the programmable controller. (Use Pr. 190 to Pr. 192 and Pr. 195 to set the output signals. Refer to page 152.)

Parameter	Name	Factory Setting	Setting Range	Description	Remarks
495	Remote output selection	0	0	Remote output data cleared at power failure	Extended mode
			1	Remote output data held at power failure	
496	Remote output data 1	0	0 to 4095	Refer to the following diagram.	
497	Remote output data 2	0	0 to 4095		

<Remote output data>  
Pr. 496

b11												b0
	DO13†	DO12†	DO11†	*	*	ABC	*	*	DO3	DO2	DO1	
	*											

\*: As desired  
\*\*.: DO11 to DO13 are available only when the extension output option (FR-V5AY) is fitted.

Pr. 497

b11												b0
	RA0	RA3	RA2	RA1	Y6	Y5	Y4	Y3	Y2	Y1	Y0	
	*	****	***	***	**	**	**	**	**	**	**	

\*: As desired  
\*\*.:Y0 to Y6 are available only when the extension output option (FR-A5AY) is fitted.  
\*\*\*.:RA1 to RA3 are available only when the extension output option (FR-A5AR) is fitted.  
\*\*\*\*.:RA0 is available only when the extension output option (FR-A5NR) is fitted.

#### (1) Operation

By setting 1 in the corresponding bit of Pr. 496, the output terminal that has been set to 96 (positive logic) or 196 (negative logic) in any of Pr. 190 to Pr. 192 and Pr. 195 turns on (off for negative logic). By setting 0, the output terminal turns off (on for negative logic).

If a power failure occurs at the Pr. 495 setting of 0, the output data are cleared to zero after power recovery and the output terminals turn on/off in accordance with the positive/negative logic settings of Pr. 190 to Pr. 192 and Pr. 195.

When the Pr. 495 setting is 1, the remote output data at occurrence of a power failure are stored into E<sup>2</sup>PROM to make the output data at power recovery the same as those at a power failure, and the on/off states of the output terminals are also made the same as those at a power failure. (They are not stored at an inverter reset.)

If the terminals of remote output and non-remote output are mixed using Pr. 190 to Pr. 192 and Pr. 195, the terminal to which remote output is not assigned will not turn on/off even if 0/1 is set in the corresponding bit of the remote output data (Pr. 496), and that terminal turns on/off with respect to the selected function.

#### (2) Others

Setting Pr. 496, Pr. 497 with the PU/DU, by computer link through the PU connector, or by communication through the communication option allows the on/off control of the remote output terminals.

Pr. 496, Pr. 497 is always accessible by making access to RAM only. When the inverter is reset, therefore, the Pr. 496, Pr. 497 setting changes to 0. When Pr. 495 = 1, however, that setting is the same as at a power failure.

If you change the Pr. 495 setting of 1 to 0 with the Pr. 496 and Pr. 497 value stored in E<sup>2</sup>PROM at occurrence of a power failure, the Pr. 496 and Pr. 497 value stored changes to 0.

#### CAUTION

**When Pr. 495 = 1, take such a step as to connect R1, S1 and P, N to ensure that control power will be retained to some degree. If you do not take such a step, the output signals provided after power on are not guaranteed.**

#### Related parameters

- Pr. 190 to Pr. 192, Pr. 195 (output terminal function selection) (Refer to page 152.)

### 3.31 Operation selection functions 4 (Pr. 800 to Pr. 809)

#### 3.31.1 Control selection (Pr. 800, Pr. 451 speed torque position )

Used to select the control method.

- Setting Pr. 800 (Pr. 451) control system selection enables the following combination using the MC signal (mode changing).

Use terminal RT to switch to the second motor control method selection.

Parameter	Name	Factory Setting	Setting Range
800	Control system selection	0	0 to 5, 9, 20
451	Second motor control method selection	9999	20, 9999

- Select the inverter control system such as speed control, torque control or position control.

Pr. 800 Setting	Control System	Control Method	Remarks
0	Vector control with encoder	Speed control	Factory setting
1		Torque control	—
2		Speed control-torque control switchover	MC ON: Torque control MC OFF: Speed control
3		Position control	—
4		Speed control-position control switchover	MC ON: Position control MC OFF: Speed control
5		Position control-torque control switchover	MC ON: Torque control MC OFF: Position control
9	Vector control test operation		
20	V/F control	Speed control	—

- When "9" is set in Pr. 800, speed control test operation can be performed even when the motor is not connected. The speed calculation value changes to track the speed command and the transition can be checked with the control panel and analog signal output at DA1 and DA2.

#### CAUTION

- When supplying power only across R1-S1, E.OC1 (overcurrent at acceleration) occurs when the start signal turns on.
- Since current is not detected and voltage is not output, monitors related to current and voltage such as output current and output voltage, etc. and output signals do not function.
- For speed calculation, speed is calculated in consideration of Pr. 880 "load inertia ratio".

#### Related parameters

MC signal terminal assignment ⇒ Set "26" in any of Pr. 180 to Pr. 183 and Pr. 187 (input terminal function selection). (Refer to page 150.)

#### 3.31.2 Torque characteristic selection (Pr. 801 speed torque position )

When using the motor with encoder, you can select the torque characteristic.

Parameter	Name	Factory Setting	Setting Range	
			Dedicated motor (SF-V5RU)	Motor with encoder (e.g. SF-JR)
801	Torque characteristic selection	1	0	Mitubishi dedicated motor
			1	torque characteristic
				Cyclic operation mode
				Continuous operation mode

#### CAUTION

- Whether the motor used is a Mitsubishi dedicated motor or motor with encoder is judged by the setting of Pr. 71 "applied motor". Refer to page 111.
- Usually, operate in the continuous operation mode (setting value: 1)  
Torque at a low speed is not sufficient in the cyclic operation mode (setting value: 0).  
Note this when changing the setting.

● Mitsubishi dedicated motor torque characteristic

Torque characteristic available when the inverter and motor of the same capacity are used and the rated voltage is input

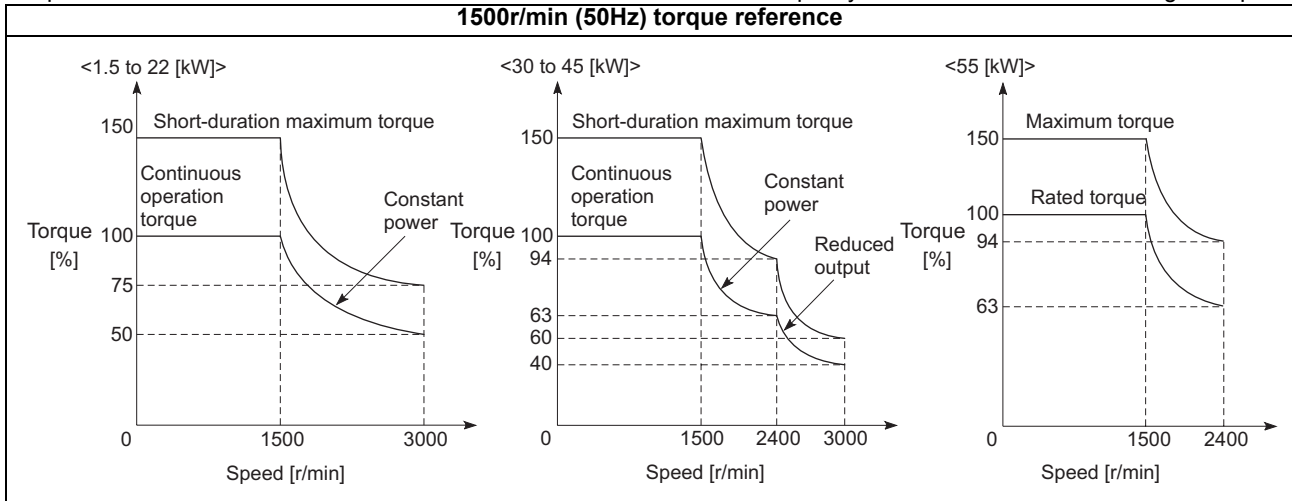

● Torque characteristic of motor with encoder (Example: SF-JR with encoder (4 poles))

Torque characteristic available when the inverter and motor of the same capacity are used and the rated voltage is input

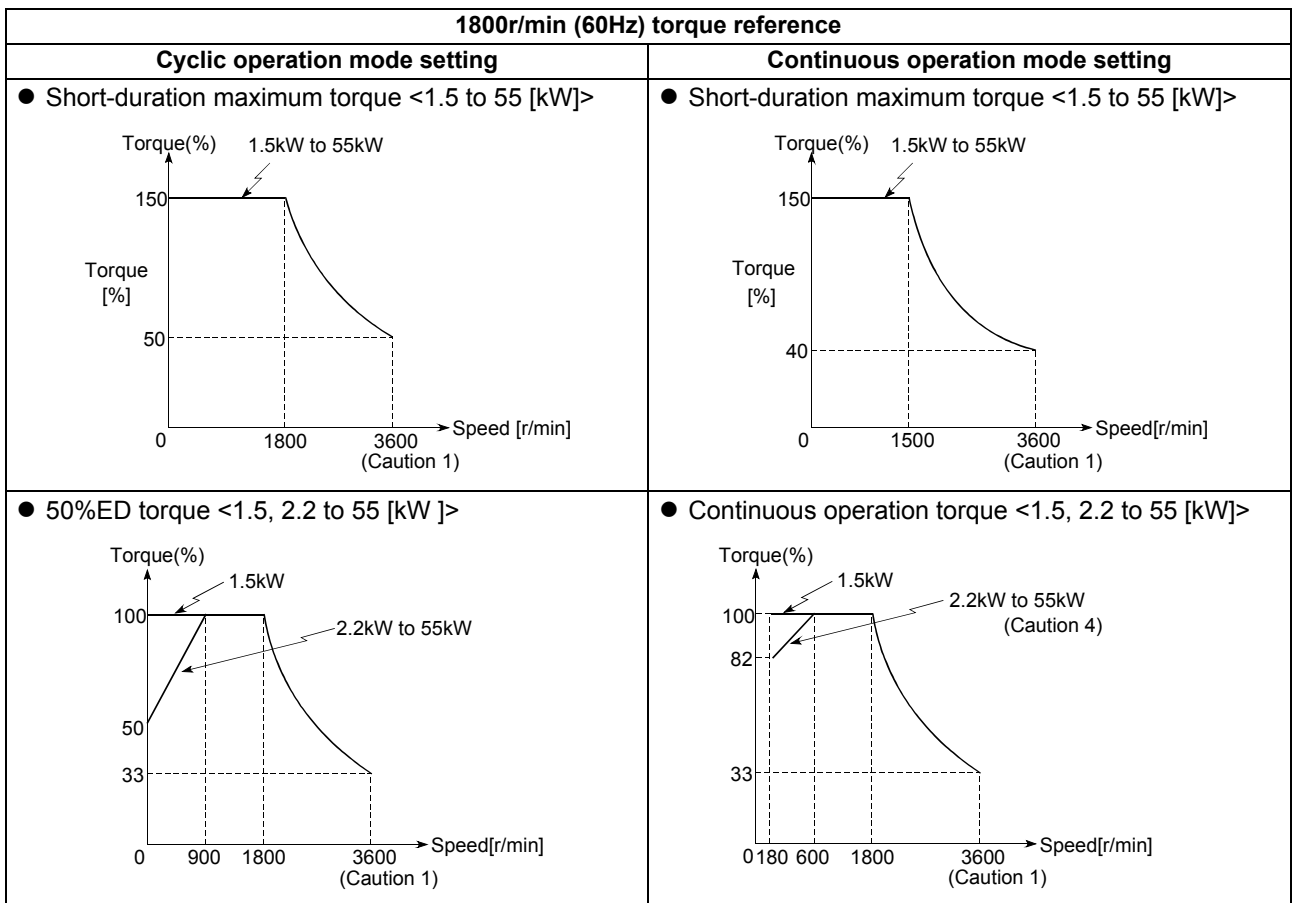

**CAUTION**

1. The maximum speeds are 1) 1.5kW to 7.5kW: 3600r/min, 2) 11kW to 30kW: 3000r/min, and 3) 37kW to 55kW: 1950r/min.
2. 50%ED continuously repeated operation can be performed at the cycle time of 10 minutes. Note that continuous operation can be performed for a maximum of 5 minutes.

Pr. 802 ➡ Refer to Pr. 10 to Pr. 12 (page 82).

Pr. 803 ➡ Refer to Pr. 22 (page 87).

### 3.31.3 Torque command source selection (Pr. 804 to Pr. 806 torque )

When you selected torque control, you can choose the torque command.

Parameter	Name	Factory Setting	Setting Range		
				Torque command input	Speed limit input method
804	Torque command source selection	0	0	Terminal 3 analog input	As set in Pr. 807.
			1	Digital input from parameter Pr. 805 or Pr. 806 setting (-400% to 400%)	
			2	Pulse train command input (FR-V5AP) Refer to the instruction manual of the option "FR-V5AP" for details.	
			3	Torque command RWw1(FR- A5NC) from the CC-Link, torque command can be set in the range of 600 to 1400% in the setting increments of 1%. Refer to the instruction manual of the option "FR-A5NC" for details.	The Pr. 808 and Pr. 809 settings are speed limit regardless of the Pr. 807 setting.
			4	Torque command from the option (digital) (FR-V5AH, FR-A5AX) Refer to the instruction manual of the option "FR-V5AH, FR-A5AX" for details.	As set in Pr. 807.
			5	Set in torque command RWw1 (FR-A5NC) from the CC-Link a value in two's complement in 0.01% increments.*1 Input in device RWw1 a two's complement value as a torque command value from the CC-Link.	The Pr. 808 and Pr. 809 settings are speed limit regardless of the Pr. 807 setting.
			6	A value is set in Pr. 805 or Pr. 806 in two's complement in 0.01% increments. Set a two's complement value as a torque command to be set in Pr. 805 or Pr. 806 from the CC-Link. The setting range is from 600 to 1400 in 1% increments setting if parameter is set from the PU04V and DU04.	As set in Pr. 807.
805	Torque command source (RAM)	1000%	600 to 1400%		
806	Torque command source (RAM, E <sup>2</sup> PROM)	1000%	600 to 1400%		

\*1 The speed limit value for Pr. 804 = "5" is the same as when Pr. 807 "speed limit selection" = "1"(speed limit using Pr. 808, Pr. 809) even if the setting is "0".

The command is speed setting command under speed/position control even when Pr. 804 = "5".

For RWw1, torque setting can be made only under torque control. During speed control, the value is input as speed command even when Pr. 804 = 5.

## Operation selection functions 4 (Pr. 800 to Pr. 809)

### (1) Terminal 3 calibration (Pr. 804 = 0)

The torque command value for the analog input of the terminal 3 varies with Pr. 904 and Pr. 905 as shown on the right.

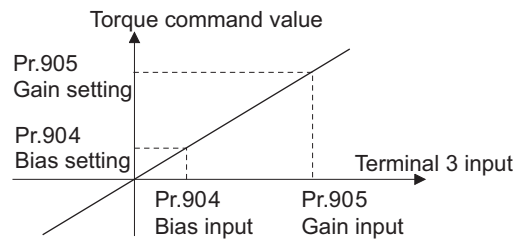

### (2) Digital input from parameter (Pr. 804 = 1)

Digital setting of the torque command can be made by writing the torque command value to Pr. 805 or Pr. 806 by communication. The torque command can also be specified by parameter direct setting. In this case, set the speed limit value to an appropriate value to prevent overspeed.

The relationship between the Pr. 805 or Pr. 806 setting and actual torque command value at this time is shown on the right. On the assumption that 1000% is 0%, the torque command is indicated by an offset from 1000%.

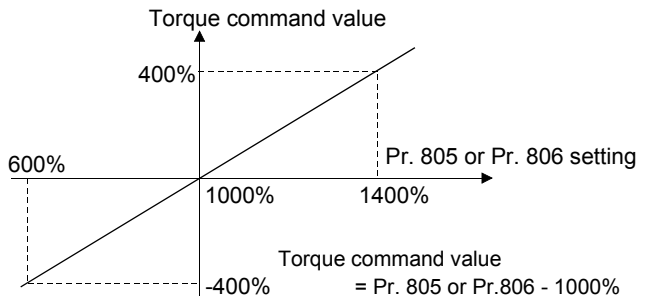

### CAUTION

When writing the torque command value by communication (Pr. 804 = 1, Pr. 804 = 3), there is a limit on the number of write times to E<sup>2</sup>PROM. When the value is changed often, write it to RAM. (When Pr. 804 = 1, set "1" in Pr. 342 "E<sup>2</sup>PROM write selection" to select write to RAM.)

### (3) Setting from the CC-Link (16bit two's complement)

Torque command	-327.68%	-100%	-50%	-25%	0%	25%	50%	100%	327.67%
	-32768	-10000	-5000	-2500	0000	2500	5000	10000	32767
Hexadecimal	8000H	D8F0H	EC78H	F63CH	0	09C4H	1388H	2710H	7FFFH
Decimal	32768	55536	60536	63036	0	2500	5000	10000	32767

### CAUTION

- The internal resolution of the torque command is 0.024% ( $100/2^{12}$ ) and the fraction less than the resolution is rounded off.
- The range of torque setting is from -327.68% to 327.67%. (-400% to 400% when shipped from the factory)
- A negative value can not be input from the control panel DU04-1 and parameter unit PU04V, a value can not be set in 0.01% increments. The setting range is from 600 to 1400% and setting increments is 1% increments. When the value set from the CC-Link is read from the PU04V or DU04-1, the value is also converted to 600 to 1400 for display.

### 3.31.4 Speed limit (Pr. 807 to Pr. 809 torque)

When you selected torque control, set the speed limit value to prevent the load torque from becoming less than the torque command value, resulting in motor overspeed.

Parameter	Name	Factory Setting	Setting Range
807	Speed limit selection	0	0, 1, 2
808	Forward rotation speed limit	1500r/min	0 to 3600r/min
809	Reverse rotation speed limit	9999	0 to 3600r/min, 9999

#### <Settings>

Set the speed limit value to prevent the load torque from becoming less than the torque command value, resulting in motor overspeed. Select the speed limit input method using Pr. 807.

Pr. 807 Setting	Speed Limit Input Method	Operation
0 (factory setting)	Same method as in speed setting for speed control	<ul style="list-style-type: none"> <li>Speed setting from the control panel</li> <li>External analog command (terminal 1, 2)</li> <li>Multi-speed command</li> <li>Option (FR-V5AX etc.)</li> <li>For both PU and external operations, speed limit changes according to the acceleration/deceleration time.</li> </ul>
1	Pr. 808 Forward rotation speed limit Pr. 809 Reverse rotation speed limit	According to the rotation direction, set the speed limits in forward and reverse rotation directions individually. When the reverse rotation speed limit is 9999, the setting is the same as that of the speed limit in the forward rotation direction.
2	Forward/reverse rotation speed limit (analog polarity switchover speed limit) (terminal 1 analog input)	The analog voltage of the terminal 1 input is used to make speed limit. For 0 to 10V input, set the forward rotation speed limit. (The reverse rotation speed limit is Pr. 1 "maximum speed" .) For -10 to 0V input, set the reverse rotation speed limit. (The forward rotation speed limit is Pr. 1 "maximum speed".) The maximum speed of both the forward and reverse rotation is Pr. 1 "maximum speed". When terminal 1 input is selected, set "5" in Pr. 868 "terminal 1 function assignment". (Refer to page 183.)

#### (1) When Pr. 807 = 0

 Refer to the Instruction Manual (basic).

#### (2) When Pr. 807 = 1

Parameter	Name	Factory Setting	Setting Range
808	Forward rotation speed limit	1500r/min	0 to 3600r/min
809	Reverse rotation speed limit	9999	0 to 3600r/min, 9999

Using the parameters, set the forward rotation and reverse rotation speed limit levels individually.

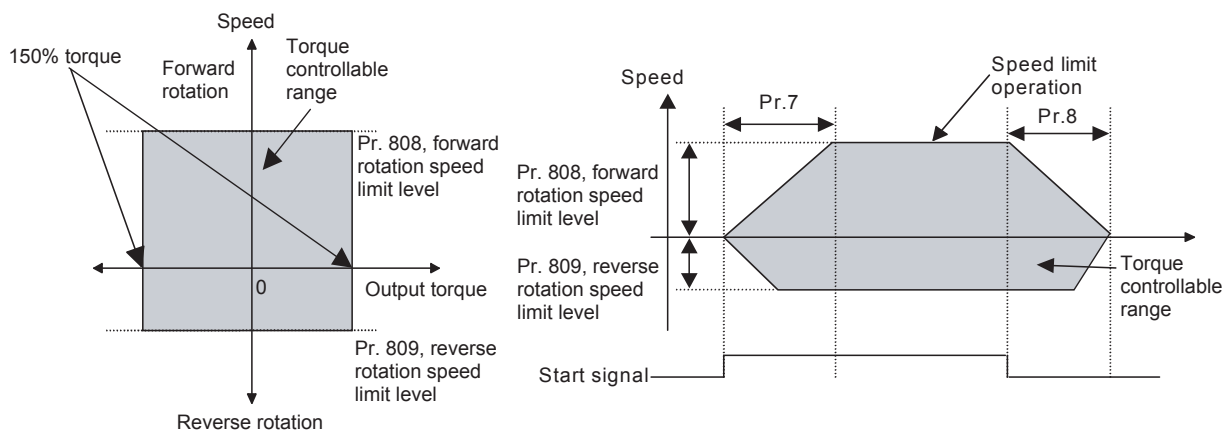

**(3) When Pr. 807 = 2**

Using the analog input of the terminal 1, set the forward rotation and reverse rotation speed limit levels. At this time, the speed limit made on the analog input is as shown below.

1) When terminal 1 input is -10 to 0V  
Reverse rotation speed limit

2) When terminal 1 input is 0V to 10V  
Forward rotation speed limit

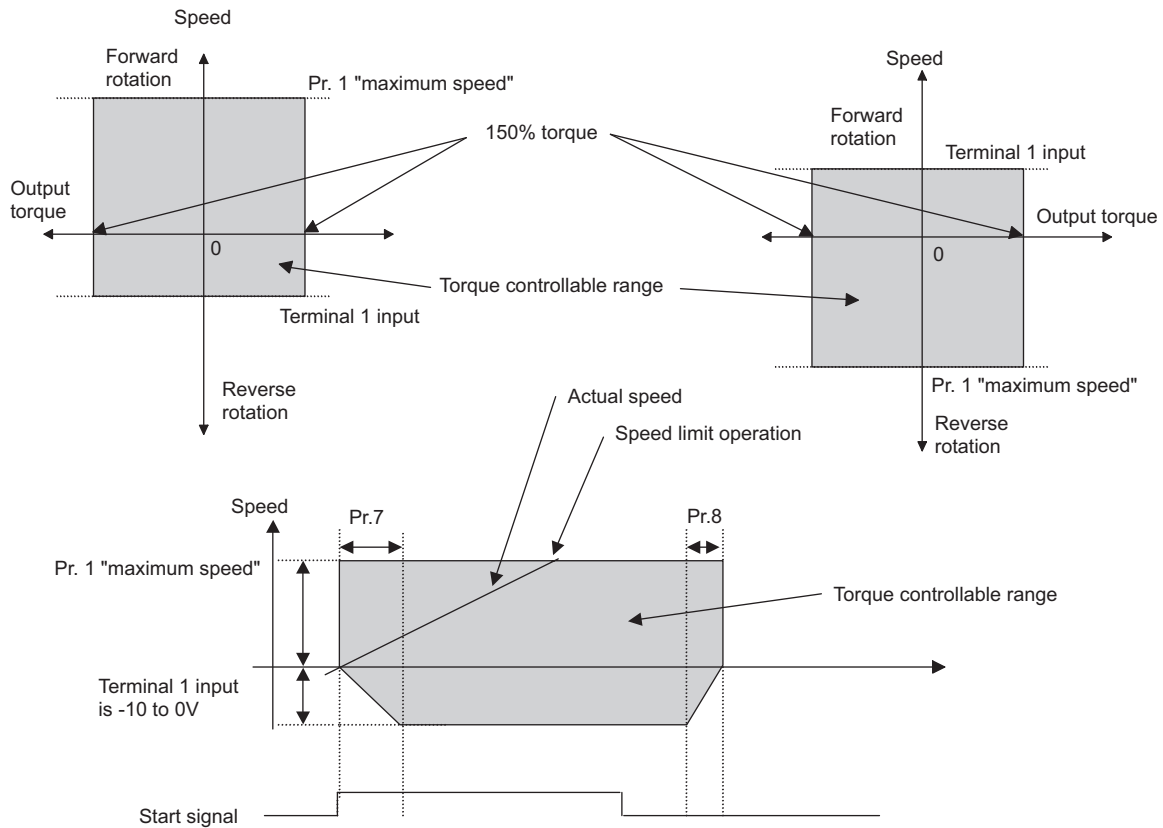

**Related parameters**

- Selection of terminal 1 function ⇒ Pr. 868 "terminal 1 function assignment" (Refer to page 183.)
- Speed limit during acceleration/deceleration ⇒ Pr. 7 "acceleration time", Pr. 8 "deceleration time" (Refer to page 78.)
- DC injection brake operation level ⇒ Pr. 10 "DC injection brake operation speed" (Refer to page 82.)
- Speed limit level maximum setting ⇒ Pr. 1 "maximum speed" (Refer to page 76.)

**CAUTION**

**When speed ≥ speed limit, torque control is switched to speed control.**

**Pr. 810, Pr. 812 to Pr. 817 → Refer to Pr. 22 (page 87)**

## 3.32 Control system functions (Pr. 818 to Pr. 837)

### 3.32.1 Easy gain tuning selection (Pr. 818, Pr. 819 speed position)

The ratio of load inertia to motor inertia (load inertia moment ratio) is estimated in real time from the torque command and speed during motor operation, and this value is used to automatically set the optimum gain for speed/position control, reducing the time and effort of making gain adjustment.

Parameter	Name	Factory Setting	Setting Range	
818	Easy gain tuning response level setting	2	1 to 15	
819	Easy gain tuning selection	0	0	No tuning
			1	With load estimation
			2	Manual load input

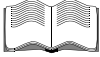

Refer to the Instruction Manual (basic) for details.

#### Related parameters

- Adjusted gains ⇒ Pr. 820 "speed control P gain 1", Pr. 821 "speed control integral time 1", Pr. 828 "model speed control gain", Pr. 422 "position loop gain"
- Adjusted load inertia ratio ⇒ Pr. 880 "load inertia ratio"

### 3.32.2 Speed loop proportional gain setting (Pr. 820, Pr. 830 speed position)

Parameter	Name	Factory Setting	Setting Range	Remarks
820	Speed control P gain 1 (when RT signal is off)	60%	0 to 1000%	Extended mode
830	Speed control P gain 2 (when RT signal is on)	9999	0 to 1000%, 9999	

- Set the proportional gain of the speed loop.  
Increasing the gain enhances the speed response level and decreases the speed fluctuation relative to disturbance, but a too large gain will produce vibration and/or sound.
- The setting range of Pr. 820 "speed control P gain 1" and Pr. 830 "speed control P gain 2" is 0 to 1000% and the factory setting is 60%. For general adjustment, set them within the range of 20 to 200%.

#### REMARKS

- The response level will be worse when the coupling is loose.
- When performing positioning, increase the setting to enhance accuracy.
- Decrease the setting when there is gear backlash, etc.

### 3.32.3 Speed control integral time setting (Pr. 821, Pr. 831 speed position)

Parameter	Name	Factory Setting	Setting Range	Remarks
821	Speed control integral time 1 (when RT signal is off)	0.333s	0 to 20s	Extended mode
831	Speed control integral time 2 (when RT signal is on)	9999	0 to 20s, 9999	

- Set the integral compensation time of the speed loop.  
If speed fluctuation occurs relative to disturbance, decreasing the value shortens the recovery time, but a too small value will cause a speed overshoot.  
A large value improves stability but increases the recovery time (response time) and may cause an undershoot.

#### REMARKS

You can switch between PI control and P control under speed control using the X44 signal. (Refer to page 34.)

### 3.32.4 Speed setting circuit filter function (Pr. 822, Pr. 832 speed position)

Set the time constant of the primary delay filter relative to the external speed command (analog input command).  
Set a large time constant when you want to delay the tracking of the speed command, when the analog input voltage fluctuates, etc.

Parameter	Name	Factory Setting	Setting Range	Remarks
822	Speed setting filter 1 (when RT signal is off)	0s (without filter)	0 to 5s	Extended mode
832	Speed setting filter 2 (when RT signal is on)	9999	0 to 5s, 9999	



**3.32.5 Speed detection filter function (Pr. 823, Pr. 833 speed torque position )**

- Set the time constant of the primary delay filter relative to the speed feedback signal. Since this function reduces the speed loop response, use it with the factory setting. Set the time constant when speed ripples occur due to harmonic disturbance. Note that a too large value will run the motor unstably.

Parameter	Name	Factory Setting	Setting Range	Remarks
823	Speed detection filter 1 (when RT signal is off)	0.001s	0 to 0.1s	0: without filter
833	Speed detection filter 2 (when RT signal is on)	9999	0 to 0.1s, 9999	9999: same as the Pr. 823 setting

Extended mode

**REMARKS**

When speed ripples are large, setting this parameter Pr. 823 or Pr. 833 ensures stability.

**3.32.6 Current loop proportional gain setting for vector control (Pr. 824, Pr. 834 speed torque position )**

- Set the current loop proportional gain for vector control. Increasing the gain enhances the torque response level, but a too large gain will cause instability, generating harmonic torque pulsation.
- Pr. 824 "torque control P gain 1" and Pr. 834 "torque control P gain 2" are 0 to 200% in the setting range and 100% in the factory setting. For general adjustment, set them within the range 50 to 200%.

Parameter	Name	Factory Setting	Setting Range	Remarks
824	Torque control P gain 1 (when RT signal is off)	100%	0 to 200%	Extended mode
834	Torque control P gain 2 (when RT signal is on)	9999	0 to 200%, 9999	

**REMARKS**

The factory setting ensures fully stable operation. For general adjustment, make setting within the range 50 to 200% as a guideline.

**3.32.7 Current control integral time setting for vector control (Pr. 825, Pr. 835 speed torque position )**

- Set the current loop integral compensation time for vector control.
- A small value enhances the torque response level, but a too small value will cause current fluctuation.

Parameter	Name	Factory Setting	Setting Range	Remarks
825	Torque control integral time 1 (when RT signal is off)	5ms	0 to 500ms	Extended mode
835	Torque control integral time 2 (when RT signal is on)	9999	0 to 500ms, 9999	

**REMARKS**

The factory setting ensures fully stable operation.

**3.32.8 Torque setting filter function (Pr. 826, Pr. 836 speed torque position )**

- Set the time constant of the primary delay filter relative to the external torque command (analog input command). Set a large time constant value when you want to delay the tracking of the torque command, the analog input voltage fluctuates, etc.

Parameter	Name	Factory Setting	Setting Range	Remarks
826	Torque setting filter 1 (when RT signal is off)	0s (without filter)	0 to 5s	Extended mode
836	Torque setting filter 2 (when RT signal is on)	9999	0 to 5s, 9999	

**3.32.9 Torque detection filter function (Pr. 827, Pr. 837 speed torque position )**

- Set the time constant of the primary delay filter relative to the torque feedback signal. Since the current loop response declines, use it with the factory setting.

Parameter	Name	Factory Setting	Setting Range	Remarks
827	Torque detection filter 1 (when RT signal is off)	0s	0 to 0.1s	Extended mode
837	Torque detection filter 2 (when RT signal is on)	9999	0 to 0.1s, 9999	

**3.32.10 Model speed control gain (Pr. 828 speed position )**

Parameter	Name	Factory Setting	Setting Range	Remarks
828	Model speed control gain	60%	0 to 1000%	Extended mode

For details, refer to page 49.

**3.33 Torque biases (Pr. 840 to Pr. 848)**

**3.33.1 Torque bias function (Pr. 840 to Pr. 848 speed )**

- This function accelerates the rise of the torque at a start. Adjust the torque at a motor start using the contact signals or analog signals .

Parameter	Name	Factory Setting	Setting Range	Remarks
840	Torque bias selection	9999	0 to 3, 9999	Extended mode
841	Torque bias 1	9999	600 to 1400%, 9999	
842	Torque bias 2	9999	600 to 1400%, 9999	
843	Torque bias 3	9999	600 to 1400%, 9999	
844	Torque bias filter	9999	0 to 5s, 9999	
845	Torque bias operation time	9999	0 to 5s, 9999	
846	Torque bias balance compensation	9999	0 to 10V, 9999	
847	Fall-time torque bias terminal 3 bias	9999	0 to 400%, 9999	
848	Fall-time torque bias terminal 3 gain	9999	0 to 400%, 9999	

Block diagram

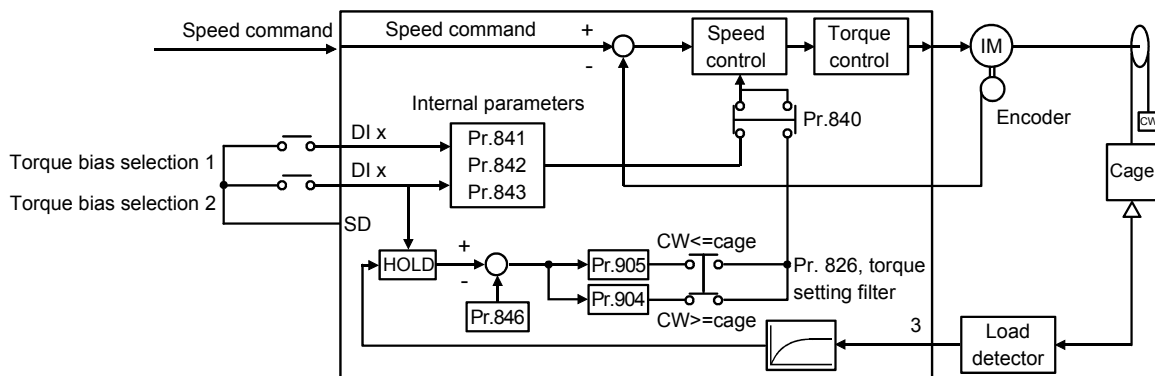

**(1) Parameter details**

1) Pr. 840 "torque bias selection"

Select the setting method of the torque bias amount.

Pr. 840 Setting	Description
0	Set the torque bias amount based on the contact signals (DI1 to DI4) in Pr. 841 to Pr. 843.
1	To raise the cage when the motor runs in forward rotation direction. Set the terminal 3-based torque bias amount as desired in Pr. 904 and Pr. 905.
2	To raise the cage when the motor runs in reverse rotation direction. Set the terminal 3-based torque bias amount as desired in Pr. 904 and Pr. 905.
3	The terminal 3-based torque bias amount can be set automatically in Pr. 904, Pr. 905 and Pr. 846 according to the load.
9999	No torque bias

**<Operation diagrams>**

- When Pr. 840 = 0

Set the torque bias values (Pr. 841 to Pr. 843) in the following table according to the combination of the contact signals (DI1 to DI4).

Torque Bias Selection 1 (X42 Terminal)	Torque Bias Selection 2 (X43 Terminal)	Torque Bias (Pr. 841 to Pr. 843)
OFF	OFF	No selection
ON	OFF	Pr.841 1000 to 1400%: Positive value 600 to 999%: Negative value
OFF	ON	Pr.842 1000 to 1400%: Positive value 600 to 999%: Negative value
ON	ON	Pr.843 1000 to 1400%: Positive value 600 to 999%: Negative value

(Example) 25% when Pr. 841 = 1025, -25% when Pr. 842 = 975, -75% when Pr. 843 = 925

- When Pr. 840 = 1

Calculate the torque bias from the analog input value of the terminal 3 as shown below and set the gain and bias (Pr. 904, Pr. 905) of the torque command.

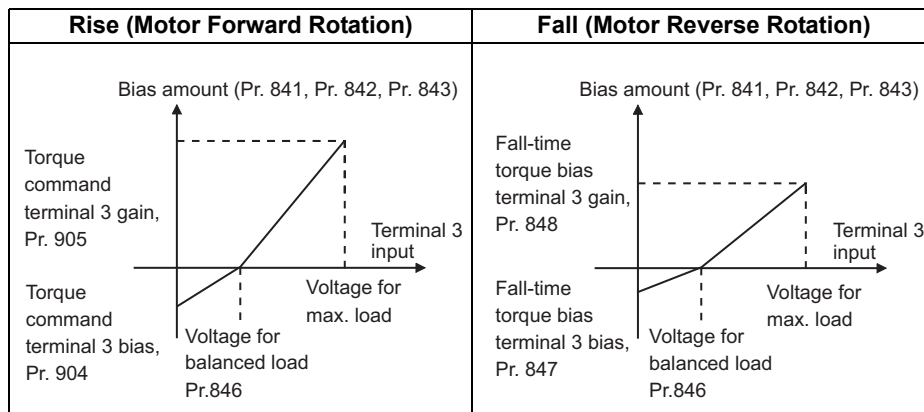

- When Pr. 840 = 2

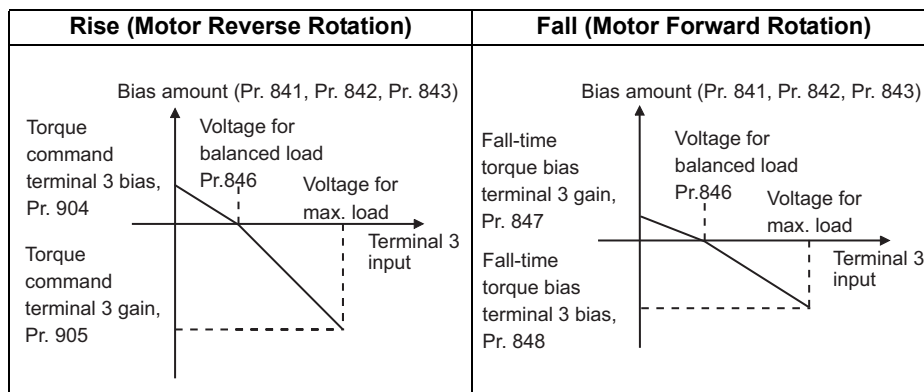

- When Pr. 840 = 3

Pr. 904 "torque command terminal 3 bias", Pr. 905 "torque command terminal 3 gain" and Pr. 846 "torque bias balance compensation" can be set automatically according to the load.

Pr. 904, Pr. 905 settings

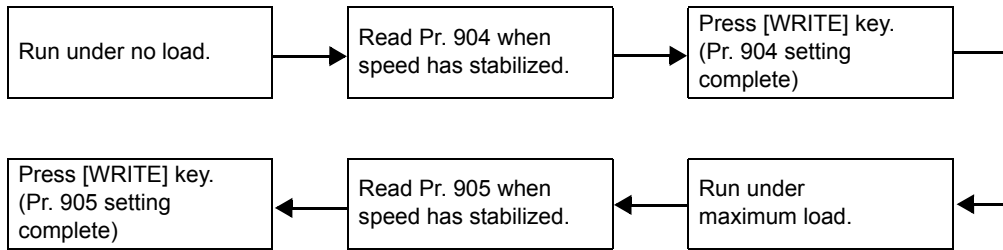

Pr. 846 setting

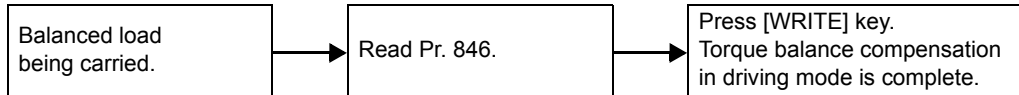

**CAUTION**

When starting torque bias operation after completion of automatic setting, set "1 or 2" in Pr. 840.

- 2) Pr. 841 "torque bias 1", Pr. 842 "torque bias 2", Pr. 843 "torque bias 3"

On the assumption that the rated torque is 100%, the torque bias setting of 1000% is the center value of torque and the bias value is "0".

Setting	Description
600 to 999%	Negative torque bias amount (-400% to -1%)
1000 to 1400%	Positive torque bias amount (0% to 400%)
9999	Without torque bias setting

- 3) Pr. 844 "torque bias filter"

You can make a torque rise gentler. At this time, the torque rises according to the time constant of the primary delay filter.

Setting	Description
0 to 5s	Time until torque rises.
9999	Same operation as when 0s is set.

- 4) Pr. 845 "torque bias operation time"

Set the time for output torque be maintained with the torque bias command value alone.

Setting	Description
0 to 5s	Time for maintaining torque equivalent to the torque bias amount.
9999	Same operation as when 0s is set.

- 5) Pr. 846 "torque bias balance compensation"

Set the voltage of the torque bias analog input value input to the terminal 3 to compensate for the balance of the torque bias amount.

Setting	Description
0 to 10V	Set the voltage under balanced load.
9999	Same operation as when 0V is set.

- 6) Pr. 847 "fall-time torque bias terminal 3 bias"

Set the torque bias amount at a fall time (when the motor runs in the reverse rotation direction).

Setting	Description
0 to 400%	Set the bias value of the torque command.
9999	Same as at a rise time (Pr. 904).

- 7) Pr. 848 "fall-time torque bias terminal 3 gain"

Set the torque bias amount at a fall time.

Setting	Description
0 to 400%	Set the gain value of the torque command.
9999	Same as at a rise time (Pr. 905).

**(2) Torque bias operation**

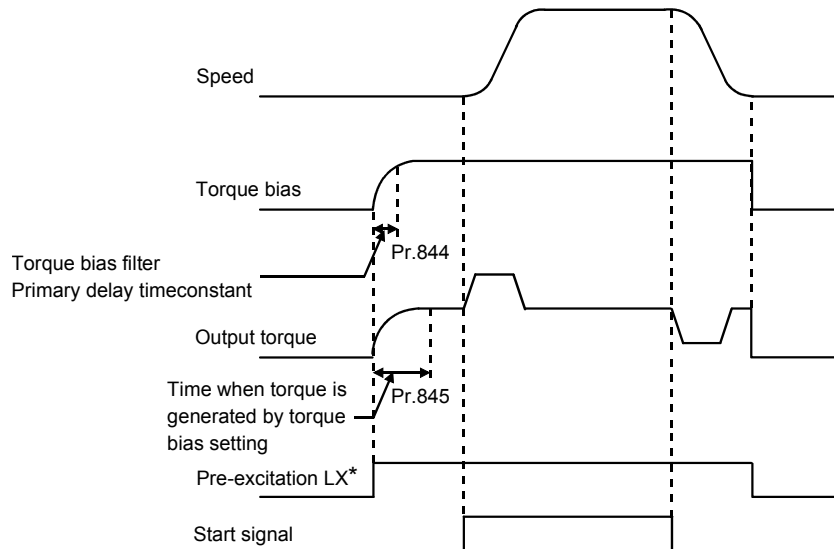

\*When pre-excitation is not made, the torque bias functions simultaneously with the start signal.

**Pr. 849** Refer to Pr. 902, Pr.903 (page 193)

**3.34 Additional functions (Pr. 851 to Pr. 865)**

**3.34.1 Selection of number of encoder pulses (Pr. 851 speed torque position )**

Set the number of pulses of the encoder fitted to the motor. (number of pulses before multiplied by 4)

Parameter	Name	Factory Setting	Setting Range
851	Number of encoder pulses	2048	0 to 4096

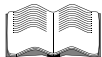

Refer to the Instruction Manual (basic) for details.

**3.34.2 Selection of encoder rotation direction (Pr. 852 speed torque position )**

You can set the rotation direction of the encoder.

Parameter	Name	Factory Setting	Setting Range	Remarks
852	Encoder rotation direction	1	0, 1	Extended mode

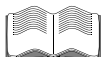

Refer to the Instruction Manual (basic) for details.

**3.34.3 Excitation ratio (Pr. 854 speed torque position )**

- Decrease the excitation ratio when you want to improve efficiency under light load. (motor magnetic noise decreases) Note that the rise of output torque becomes slow if excitation ratio is decreased. This function is appropriate for applications as machine tools which repeat rapid acceleration/deceleration up to high speed.

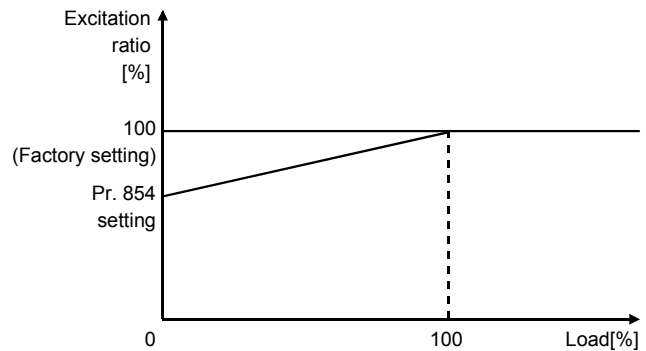

Parameter	Name	Factory Setting	Setting Range	Remarks
854	Excitation ratio	100%	0 to 100%	Extended mode

**REMARKS**

When "1" (magnetic flux command from the terminal 1) is set in Pr. 868 "terminal 1 function assignment", this Pr. 854 setting is made invalid.

Pr. 859 ➔ Refer to page 123

**3.34.4 Notch filter (Pr. 862, Pr. 863 speed position )**

You can reduce the response level of speed control in the resonance frequency band of the mechanical system to avoid mechanical resonance.

Parameter	Name	Setting Range	Increments	Factory Setting	Remarks
862	Notch filter frequency	0 to 31	1	0	0: Function invalid Extended mode
863	Notch filter depth	0 to 3	1	0	

●Pr. 862 "notch filter frequency"

Pr. 862 Setting	Frequency	Pr. 862 Setting	Frequency	Pr. 862 Setting	Frequency	Pr. 862 Setting	Frequency
0	invalid	8	140.6	16	70.3	24	46.9
1	1125.0	9	125.0	17	66.2	25	45.0
2	562.5	10	112.5	18	62.5	26	43.3
3	375.0	11	102.3	19	59.2	27	41.7
4	281.3	12	93.8	20	56.3	28	40.2
5	225.0	13	86.5	21	53.6	29	38.8
6	187.5	14	80.4	22	51.1	30	37.5
7	160.7	15	75.0	23	48.9	31	36.3

●Pr. 863 "notch filter depth"

Pr. 863 Setting	Depth (Gain)
0	deep (-40dB)
1	↑ (-14dB)
2	↓ (-8dB)
3	sharow (-4dB)

**CAUTION**

- If you do not know the mechanical resonance frequency, decrease notch frequency gradually from the highest value. The point at which the smallest vibration is generated is the notch frequency setting.
- The notch filter with deeper depth has an effect on minimizing mechanical resonance. However, large vibration may be generated adversely due to substantial phase delay.
- Machine characteristic can be obtained beforehand with machine analyzer by setup software. Necessary notch frequency can be determined from this.

**3.34.5 Torque detection (Pr. 864 speed torque position )**

This function outputs a signal if the motor torque rises to or above the Pr. 864 setting. The signal is used as operation and open signal for an electromagnetic brake.

Parameter	Name	Factory Setting	Setting Range	Remarks
864	Torque detection	150%	0 to 400%	Extended mode

The signal turns on when the output torque rises to or above the detection torque value set in Pr. 864. It turns off when the torque falls below the detection torque value.

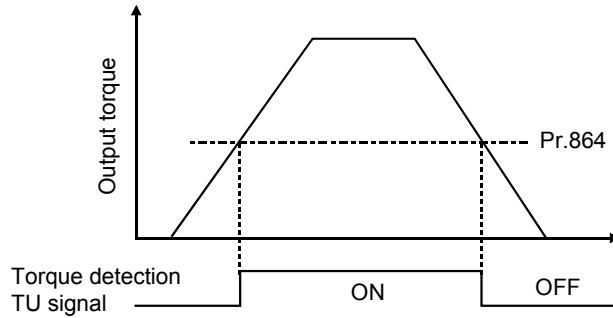

**Related parameters**

TU signal terminal assignment ⇒ Set "35" in any of Pr. 190 to Pr. 192 and Pr. 195 (output terminal function selection). (Refer to page 152.)

**3.34.6 Low speed detection (Pr. 865 speed torque position )**

This function outputs a signal if the speed falls to or below the Pr. 865 setting.

Parameter	Name	Factory Setting	Setting Range	Remarks
865	Low speed detection	45r/min	0 to 3600r/min	Extended mode

**<Operation>**

The signal is output during inverter operation under the following conditions.

- (1) Vector control  
 Motor speed ≤ Pr. 865 ... ON  
 Motor speed > Pr. 865 ... OFF
- (2) V/F control  
 Output speed ≤ Pr. 865 speed equivalent ... ON  
 Output speed > Pr. 865 speed equivalent ... OFF

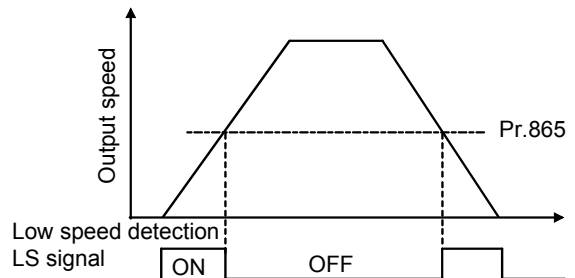

**REMARKS**

When "0" is set, low speed detection (LS signal) is output under position control only.

**Related parameters**

LS signal terminal assignment ⇒ Set "34" in any of Pr. 190 to Pr. 192 and Pr. 195 (output terminal function selection). (Refer to page 152.)

**Pr. 866** ➔ Refer to Pr. 55 (page 100)

### 3.35 Display function (Pr. 867)

#### 3.35.1 DA1 output response level adjustment (Pr. 867 speed torque position)

You can adjust the response level of the output voltage of the output signal DA1.

Parameter	Name	Factory Setting	Setting Range	Remarks
867	DA1 output filter	0.05s	0 to 5s	Extended mode

### 3.36 Terminal function assignment (Pr. 868)

#### 3.36.1 Terminal 1 function assignment (Pr. 868 speed torque position)

The terminal 1 can be multi-functioned.

Parameter	Name	Factory Setting	Setting Range	Remarks
868	Terminal 1 function assignment	0	0, 1, 2, 5, 9999	Extended mode

<Terminal 1 function according to control>

Pr. 868 Setting	Terminal 1 Function under Speed Control	Terminal 1 Function under Torque Control	Terminal 1 Function under Position Control	Bias/Gain Setting	Remarks
0 (factory setting)	Speed setting auxiliary *	Speed limit auxiliary	No function	Pr. 902 "speed setting terminal 2 bias" Pr. 903 "speed setting terminal 2 gain"	
1	Magnetic flux command	Magnetic flux command	Magnetic flux command	Pr. 919 "terminal 1 bias (torque/magnetic flux)" Pr. 920 "terminal 1 gain (torque/magnetic flux)"	
2	Regenerative torque limit	No function	Regenerative torque limit	Pr. 919 "terminal 1 bias (torque/magnetic flux)" Pr. 920 "terminal 1 gain (torque/magnetic flux)"	Setting can be made when Pr. 810 = 1.
5	No function	Forward/reverse rotation speed limit (analog polarity switchover speed limit)	No function	Pr. 917 "terminal 1 bias (speed)" Pr. 918 "terminal 1 gain (speed)"	
9999	No function	No function	No function	No function	No function

\* The function is changed to main speed according to the Pr.73 setting with which override, polarity reversible function, etc. can be selected. (Refer to page 113.)

#### REMARKS

Refer to page 190 for bias/gain settings.



## Protective functions (Pr. 870 to Pr. 874)

### <Detailed operation>

The following table indicates the functional combinations of terminals 1, 2 and 3.

Basically, the analog multiple functions are assigned to the terminal 1 alone and only one function may be selected for the multi-function analog input.

Control Method	Terminal 2 Speed Command/ Speed Limit/ PID Set Point	Terminal 3 Torque Limit/Torque Command/Torque Bias	Terminal 1 Multi-function	Remarks
Speed control	Speed command	No function (Pr. 810 = 0, Pr. 840 = 9999)	Speed auxiliary setting (Reversible operation also possible) Magnetic flux command	Factory-set status
		Torque limit (Pr. 810 = 1)	Speed auxiliary setting (Reversible operation also possible) Magnetic flux command	
		Torque bias (Pr. 810 = 0, Pr. 840 = 1,2,3)	Regenerative torque limit	Setting can be made when Pr. 810 = 1.
			Speed setting auxiliary Magnetic flux command	
PID control (Speed control)	PID set point	No function (Pr. 810 = 0)	PID measured value PID deviation signal	
		Torque limit (Pr. 810 = 1)	PID measured value PID deviation signal	
Torque control	Speed limit	Torque command	Speed limit auxiliary input Magnetic flux command	
	No function		Forward/reverse rotation speed limit (analog polarity switchover speed limit)	Setting can be made when Pr. 807 = 2.
Position control	No function	No function (Pr. 810 = 0)	No function Magnetic flux command	
		Torque limit (Pr. 810 = 1)	No function Magnetic flux command	
			Regenerative torque limit	Setting can be made when Pr. 810 = 1.

When the PID control function is selected, the terminal 2 is used for the PID set point. For PID control, refer to page 139.

When the torque bias function is selected, the terminal 3 is used for the torque bias input.

#### REMARKS

Magnetic flux command is a function used to command magnetic flux (strength of magnetic flux) from the external analog terminal (1). In addition to torque command "terminal 3", the inverter can control torque using magnetic flux as a command. For example, the characteristic of motor torque is that output torque is constant independently of the output speed when exercising line feed/tension constant control on a winder, unwinder, etc. Constant power control by variable magnetic flux, equivalent to field excitation control of the DC shunt motor, can be exercised.

## 3.37 Protective functions (Pr. 870 to Pr. 874)

### 3.37.1 Speed deviation excessive (Pr. 870, Pr. 871 speed )

- If the difference (absolute value) between the speed command value and actual speed exceeds the Pr. 870 "speed deviation level" setting for longer than the time set in Pr. 871 "speed deviation time", speed deviation excessive occurs and error "E. OSD" appears, resulting in a stop.

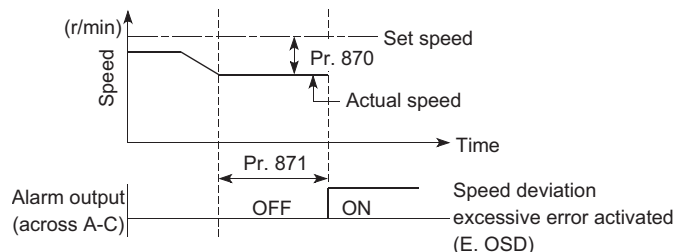

Parameter	Name	Factory Setting	Setting Range	Remarks
870	Speed deviation level	9999	0 to 1500r/min, 9999	9999:Invalid
871	Speed deviation time	12s	0 to 100s	---

#### REMARKS

1. Set these parameters when a speed difference will pose a problem.
2. This function is activated only under vector control.
3. When the motor with encoder is driven, setting the Pr. 851 "number of encoder pulses" value that is different from the actual number of encoder pulses may make control unstable, resulting in "E. OSD" (even if Pr. 870 = 9999).

### 3.37.2 Speed limit (Pr. 873 speed )

This function prevents the motor from overrunning when the setting of number of encoder pulses and the actual number differ. When the setting of number of encoder pulses is smaller than the actual number, the motor may increase its speed. To prevent this, restrict the output speed with the synchronous speed obtained by adding the set speed and Pr. 873 setting. (\*)

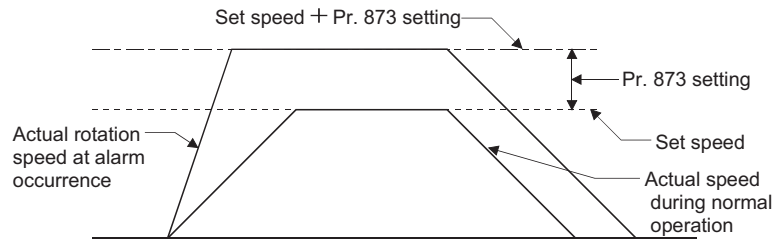

Parameter	Name	Factory Setting	Setting Range	Remarks
873	Speed limit	600r/min	0 to 3600r/min	Extended mode

#### CAUTION

\* When the setting of number of the encoder pulses is smaller than the actual number, selecting automatic restart after instantaneous power failure function (set a value other than "9999" in Pr. 57) restrict the output speed with the synchronous speed obtained by adding the maximum speed (Pr. 1) and Pr. 873 setting.

### 3.37.3 Stop by OLT level prevention (Pr. 874 speed position )

This function can make an alarm stop if the torque limit is activated to stall the motor.

Parameter	Name	Factory Setting	Setting Range	Remarks
874	OLT level setting	150%	0 to 200%	Extended mode

- (1) Speed control, position control  
 The motor stalls if the torque limit is activated under a high load applied during speed control or position control. At this time, if the motor speed is lower than the speed set in Pr. 865 (low speed detection) and also the output torque exceeds the level set in Pr. 874 for 3s, it is regarded as a stop effected by stall prevention and E. OLT is output, resulting in an alarm stop.

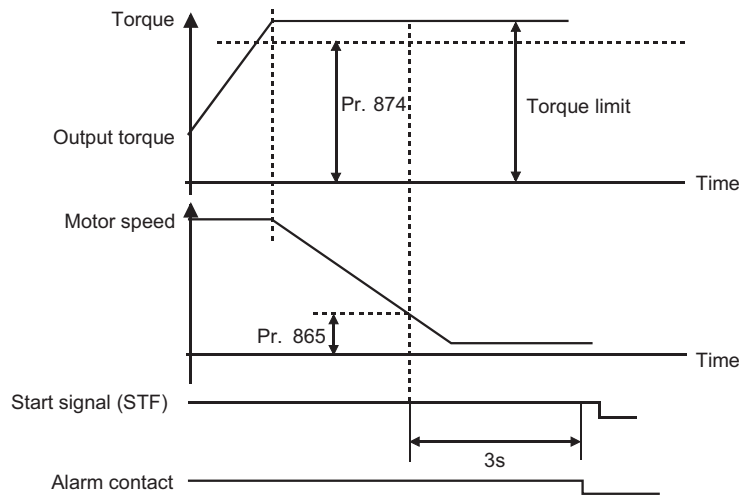

If torque limit is activated and speed falls below Pr. 865 setting, OLT alarm does not occur when output torque at this time is lower than Pr. 874.

- (2) V/F control  
 If the stall prevention function is activated and the output frequency is kept reduced to 0Hz for 3s, OLT will cause an alarm stop.  
 In this case, this function is activated regardless of Pr. 874.
- (3) Torque control  
 This alarm is not activated.

#### Related parameters

- Low speed detection ⇒ Pr. 865 "low speed detection" (Refer to page 182.)

### 3.38 Operation selection functions 5 (Pr. 875)

#### 3.38.1 Fault definition (Pr. 875 **speed** **torque** )

With the alarm definitions classified into major and minor faults, the base circuit is shut off immediately at occurrence of a major fault, or after deceleration to a stop at occurrence of a minor fault.

Parameter	Name	Factory Setting	Setting Range	Remarks
875	Fault definition	0	0, 1	Extended mode

- 1) Pr. 875 = 0: Normal operation  
At occurrence of any alarm, the base circuit is shut off immediately. At this time, the alarm output also turns on.
- 2) Pr. 875 = 1: Fault definition  
At occurrence of OHT or THM alarm, the motor is decelerated to a stop. At this time, minor fault output 2 (ER) signal turns on and the base circuit is shut off when the DC brake operation starts after deceleration.  
When the ER signal turns on, the electronic thermal relay function is activated and the inverter decelerates to a stop. Decrease load, etc. to allow the inverter to decelerate.  
At occurrence of an alarm other than OHT or THM, the base circuit is shut off immediately.

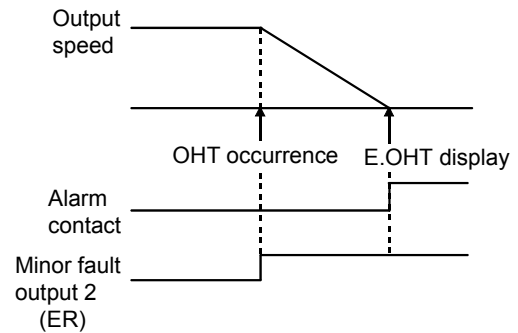

#### CAUTION

This function is invalid during position control.  
The value "0" is recommended for the system in which the motor continues running without deceleration due to a large torque on the load side.

Pr.876 ➡ Refer to Pr.9 (page 80).

### 3.39 Control system function 2 (Pr. 877 to Pr. 881)

#### 3.39.1 Speed feed forward control, model adaptive speed control

(Pr. 877 to Pr. 881 **speed** **position** )

By making parameter setting, select the speed feed forward control or model adaptive speed control. The speed feed forward control enhances the trackability of the motor in response to a speed command change. The model adaptive speed control enables individual adjustment of speed trackability and motor disturbance torque response.

Parameter	Name	Factory Setting	Setting Range
877	Speed feed forward control/model adaptive speed control selection	0	0, 1, 2
878	Speed feed forward filter	0s	0 to 1s
879	Speed feed forward torque limit	150%	0 to 400%
880	Load inertia ratio	7	0, 1 to 200 times
881	Speed feed forward gain	0%	0 to 1000%

Refer to page 49 for details.

### 3.40 Maintenance function (Pr. 890 to Pr. 892)

#### 3.40.1 Maintenance output function (Pr. 890 to Pr. 892 speed torque position )

When the cumulative energization time (Pr. 891 "maintenance output timer") of the inverter has elapsed the time set in Pr. 890 "maintenance output setting time", the maintenance output (MT) signal is output and an alarm is displayed on the PU (FR-DU04-1/FR-PU04V). A repetition signal output and alarm display at specified intervals can be set using Pr. 890 "maintenance output setting time". (usable for a capacitor life alarm, etc.)

Parameter	Name	Factory Setting	Setting Range	Remarks
890	Maintenance output setting time	9999	0 to 9998, 9999	9999: Function invalid
891	Maintenance output timer	0	0 to 9998	Extended mode
892	Maintenance output signal clear	0	0	

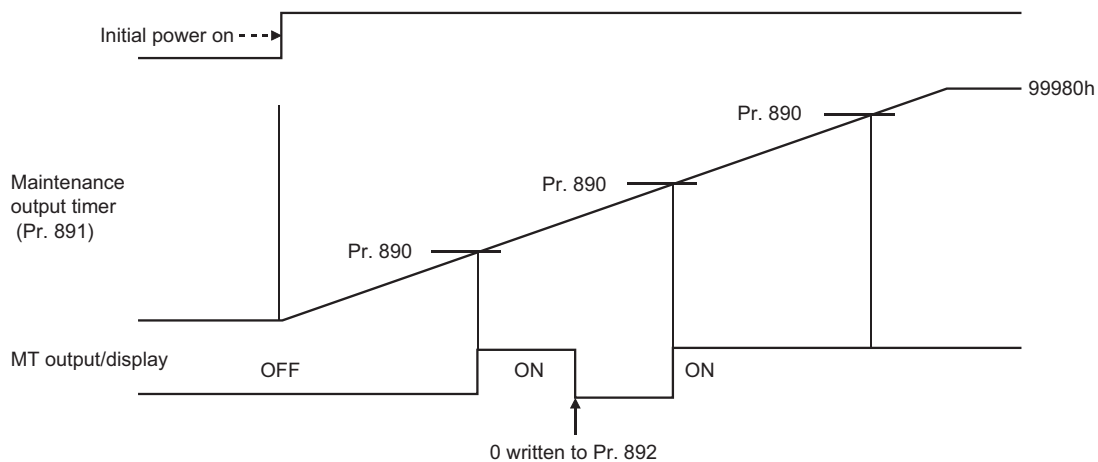

- The maintenance output timer count displayed on the FR-DU04-1 is clamped at 9998 (99980h).
- Writing 0 to Pr. 892 enables the maintenance (MT) output/display to be turned off. (This is designed to turn it off only when the user intends to turn it off.)
- When the Pr. 891 setting is less than the Pr. 890 value, the maintenance output turns off.

##### 1) Pr. 891 "Maintenance output timer"

The cumulative energization time of the inverter is counted every 1hr and the stored time in E<sup>2</sup>PROM is output in 10hrs increment.

##### REMARKS

- The time is counted regardless of the Pr. 890 "maintenance output setting time" value.
- The timer can be cleared by setting "0" in Pr. 891 when Pr. 77 = "801". Make sure that the Pr. 77 value is reset to the original value.

##### 2) Setting the MT signal

Set "37" (maintenance output signal) in Pr. 190 to Pr. 192 or Pr. 195 (output terminal function selection) to set the MT signal. (Refer to page 152)

## 3.41 Calibration functions (Pr. 900 to Pr. 920)

### 3.41.1 DA1/DA2 terminal calibration (Pr. 900, Pr. 901 speed torque position)

Pr. 900 "DA1 terminal calibration"

Pr. 901 "DA2 terminal calibration"

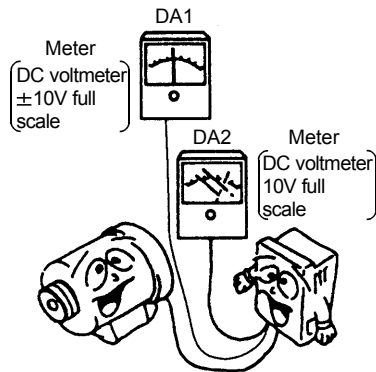

- When the item to be monitored is selected and set in Pr. 54 "DA1 terminal function selection" or Pr. 158 "DA2 terminal function selection", the inverter is factory-set to provide a 10VDC output in the full-scale status of the corresponding monitor item as described in the section of Pr. 54 and Pr. 158. These parameters allow the output voltage ratios (gains) to be adjusted according to the meter scale. Note that the maximum output voltage is 10VDC. (Terminal DA1 can also provide a -10VDC output.) (Refer to page 97 for Pr. 54 and Pr. 158.)

**CAUTION**  
**DA1 and DA2 output voltage even at an alarm stop.**

#### (1) Calibration of DA1 terminal

- 1) Connect a meter (speed meter) across inverter terminals DA1-5. (Note the polarity. DA1 is positive.)
- 2) When a calibration resistor has already been connected, adjust the resistance to "0" or remove the resistor.
- 3) Set any of "1 to 3, 5 to 12, 17, 18, 21, 32 to 34 and 36" in Pr. 54.  
When the speed, inverter output current etc. has been selected as the output signal, preset in Pr. 55, Pr. 56 or Pr. 866 the speed, current value or torque at which the output signal is 1500r/min.  
At this 1500r/min or rated current, the meter is normally deflected to full scale.
- 4) When outputting the item that cannot achieve a 100% value easily by operation, e.g. output current, set "21" (reference voltage output) in Pr. 158 and perform the following operation. After that, set "2" (output current, for example) in Pr. 158.

#### (2) Calibration of terminal DA2

- 1) Connect a 0-10VDC meter (speed meter) to across inverter terminals DA2-5. (Note the polarity. DA2 is positive.)
- 2) Set any of "1 to 3, 5 to 12, 17, 18, 21, 32 to 34, 36" in Pr. 158.  
When the speed, inverter output current or the like has been selected as the output signal, preset in Pr. 55, Pr. 56 or Pr. 866 the speed, current value or torque at which the output signal is 10V.
- 3) When outputting the item that cannot achieve a 100% value easily by operation, e.g. output current, set "21" (reference voltage output) in Pr. 158 and perform the following operation. After that, set "2" (output current, for example) in Pr. 158.

<Operating procedure>

- When control panel (FR-DU04-1) is used

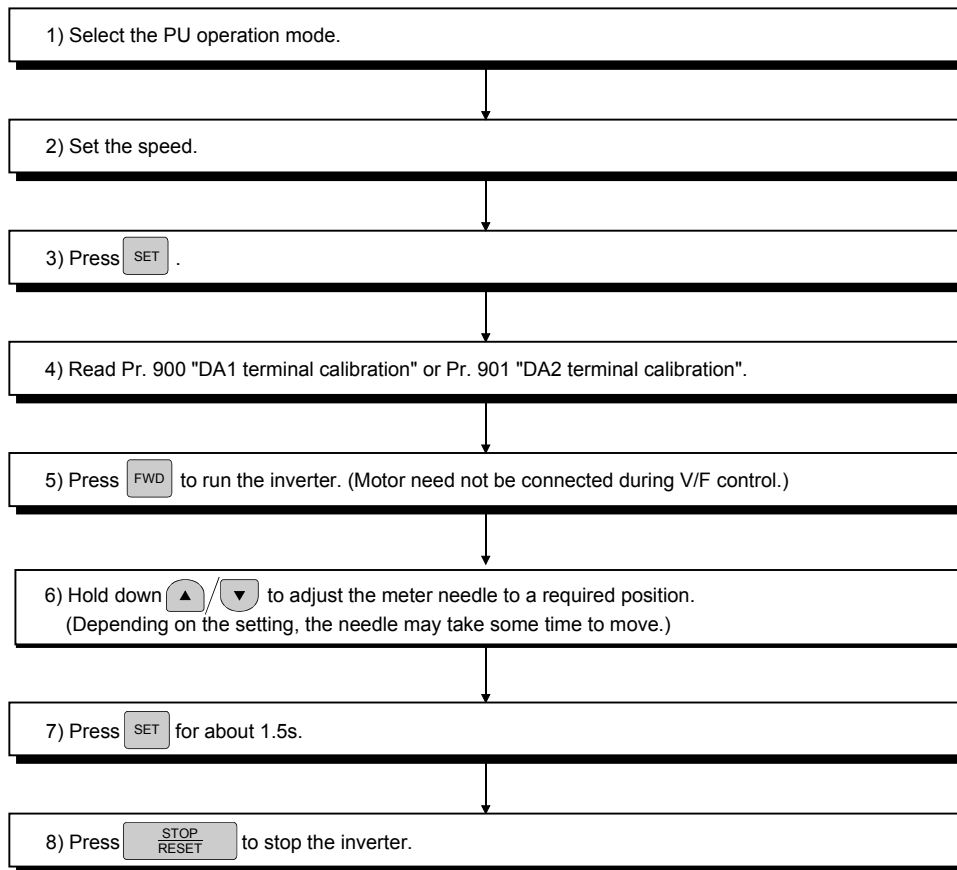

**REMARKS**

Calibration can also be made for external operation. Set the speed in the external operation mode and make calibration as in steps 4) to 8).

**CAUTION**

1. Calibration can be made even during operation.
2. Refer to the FR-PU04V instruction manual for the operating procedure using the parameter unit (FR-PU04V).

**Related parameters**

- Pr. 54 "DA1 terminal function selection" (Refer to page 97.)
- Pr. 55 "speed monitoring reference" (Refer to page 100.)
- Pr. 56 "current monitoring reference" (Refer to page 100.)
- Pr. 158 "DA2 terminal function selection" (Refer to page 97.)

**3.41.2 Biases and gains of speed setting terminals**  
 (speed setting terminal 2, torque command terminal 3, multi function terminal 1)  
 (Pr. 902 to Pr. 905, Pr. 917 to Pr. 920 speed torque position )

Adjust the biases and gains of the speed setting terminal 2, torque command terminal 3 and multi-function terminal 1.  
 The "bias" and "gain" functions are designed to adjust the relationship between the 0 to 10V input signal, which is externally input for the setting of output speed, torque or magnetic flux.

Parameter	Name	Factory Setting (*2)		Setting Range		Remarks
902	Speed setting terminal 2 bias	0V	0r/min	0 to 10V	0 to 3600r/min	Extended mode
903	Speed setting terminal 2 gain	10V	1500r/min	0 to 10V	0 to 3600r/min	
904	Torque command terminal 3 bias	0V	0%	0 to 10V	0 to 400%	
905	Torque command terminal 3 gain	10V	150%	0 to 10V	0 to 400%	
917	Terminal 1 bias (speed *1)	0V	0r/min	0 to 10V	0 to 3600r/min	
918	Terminal 1 gain (speed *1)	10V	1500r/min	0 to 10V	0 to 3600r/min	
919	Terminal 1 bias (torque/magnetic flux)	0V	0%	0 to 10V	0 to 400%	
920	Terminal 1 gain (torque/magnetic flux)	10V	150%	0 to 10V	0 to 400%	

\*1 For calibration of forward/reverse rotation limit, PID control deviation and measured value.

\*2 Factory settings may differ because of calibration parameters.

Parameter	Calibration Terminal	Speed Command/Speed Limit (Pr. 807, Pr. 868, Pr. 73)			Forward/Reverse Rotation Speed Limit	Torque			Magnetic Flux	PID Control (Pr. 128 to Pr. 134)		
		Speed (main speed+ auxiliary)	Compensation input	Override		Magnetic flux command	Torque limit (Pr. 810)	Torque command (Pr. 804)		Torque bias (Pr. 840)	Deviation	Set point
902	terminal 2 (+terminal 1)	●	●	● (terminal 1)						●		
903												
904	terminal 3 only					●	●	●				
905												
917	terminal 1 only				● (Pr. 868)					●	●	
918												
919						● (regenerative torque limit (Pr. 868))			● (Pr. 868)			
920												

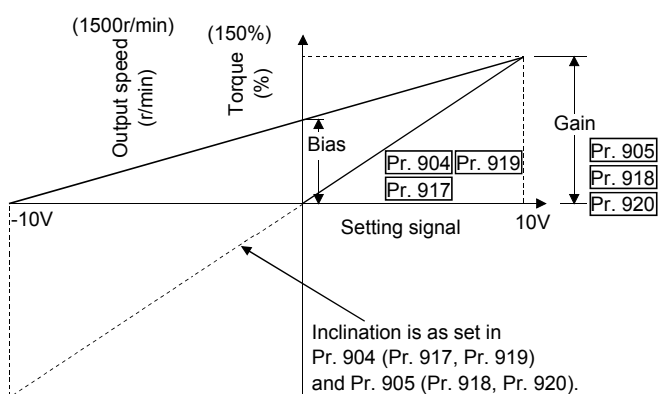
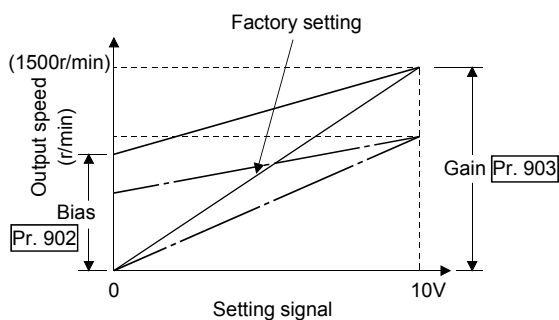

**CAUTION**

Torque command bias and gain can not be set by applying an external negative setting signal to the torque command terminal 3 or 1.

<Setting>



There are the following three methods to adjust the speed setting voltage bias and gain.

- 1) Method to adjust any point by application of a voltage to across terminals 2(1)(3) - 5
- 2) Method to adjust any point without application of a voltage to across terminals 2(1)(3) - 5
- 3) Method that does not adjust the bias voltage

**(Example) Pr. 903 "speed setting terminal 2 gain"**

(Pr. 902 to Pr. 920 can be adjusted in the similar manner.)

<Adjustment procedure> Using the speed setting signal from the control panel (FR-DU04-1) to make speed setting

<p>(1) Power on (monitoring mode)</p>  <p><b>REMARKS</b> ON of the LED is indicated by ○, and OFF by ●.</p>	<p>(2) Choose the PU operation mode.</p> <p>1) Press <b>MODE</b> to make sure that the inverter is in the PU operation mode. (LED of PU is lit.) (Refer to the Instruction Manual (basic) for monitor transition.)</p> <p>● Operation mode (PU operation mode)</p> 
--	---

- 2) Set 1 (PU operation mode) in Pr. 79 "operation mode selection". (Refer to page 117.)  
 Example: To change the external operation mode (Pr. 79 = 2) to the PU operation mode (Pr. 79 = 1)

Press **MODE** to choose the "parameter setting mode".

● Parameter setting mode

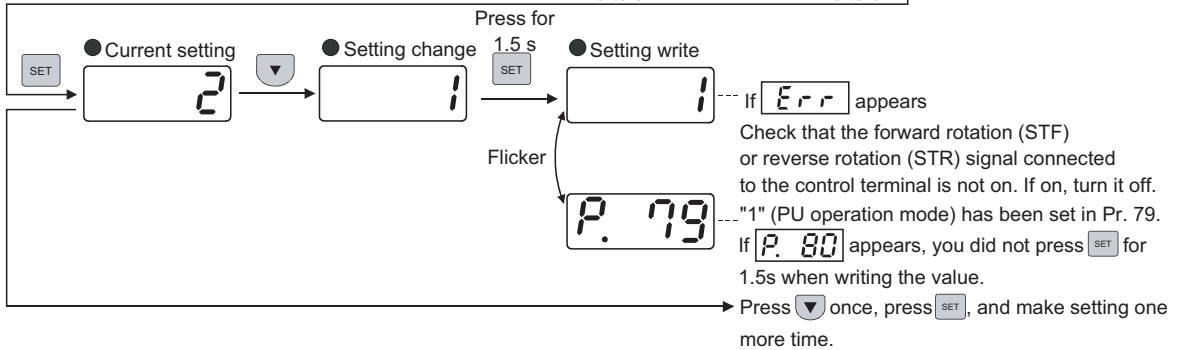
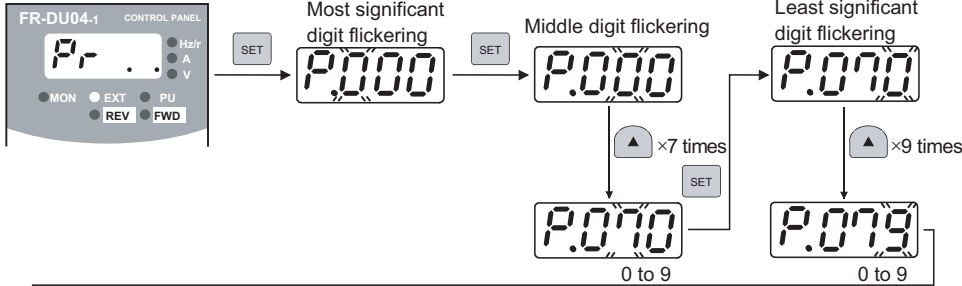

- (3) Read Pr. 903 to display the currently set gain speed.

● Parameter setting mode

Press **MODE** to choose the "parameter setting mode".

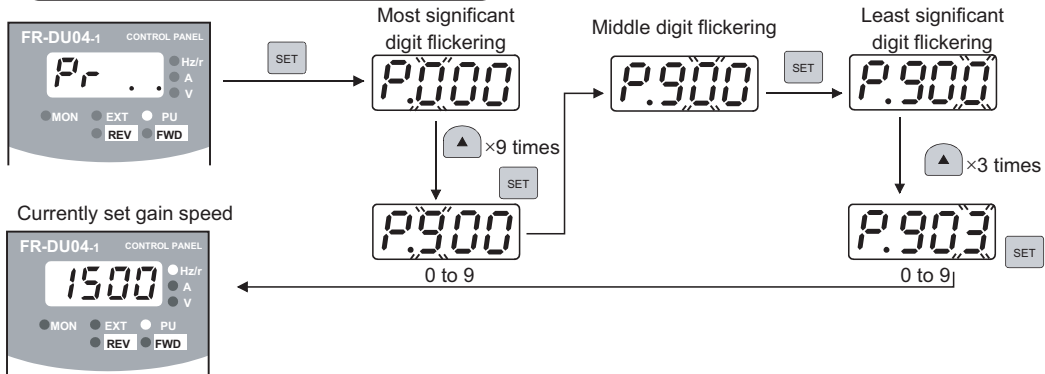



(4) Set the gain speed in Pr. 903 and display the analog voltage value across terminals 2-5 in %.  
(To change to 1000r/min)

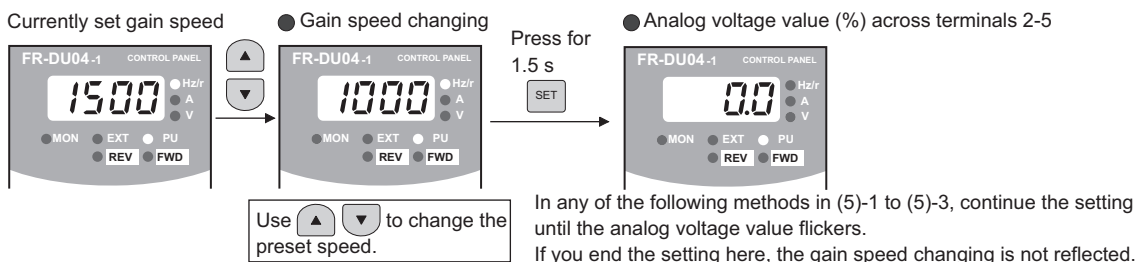

- When not adjusting the gain voltage → To (5)-1
- When adjusting any point by application of voltage → To (5)-2
- When adjusting any point without application of voltage → To (5)-3

(5)-1 Method to adjust only the gain speed and not to adjust the voltage

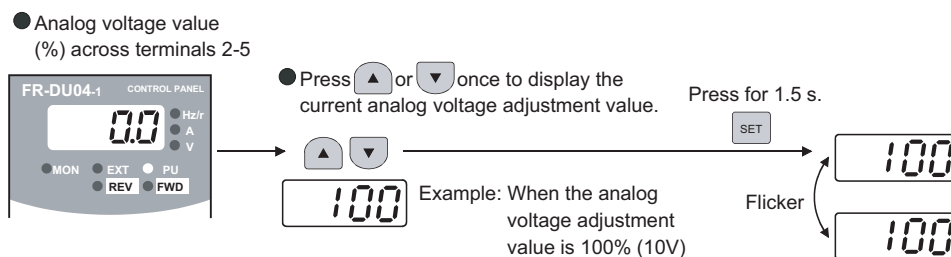

(5)-2 Method to adjust any point by application of voltage to across terminals 2-5 (e.g. applied from external potentiometer)

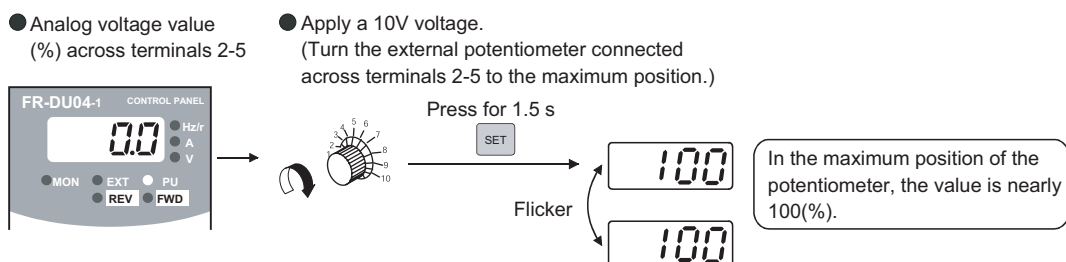

(5)-3 Method to adjust any point without application of voltage to across terminals 2-5 (To change from 80% to 100%)

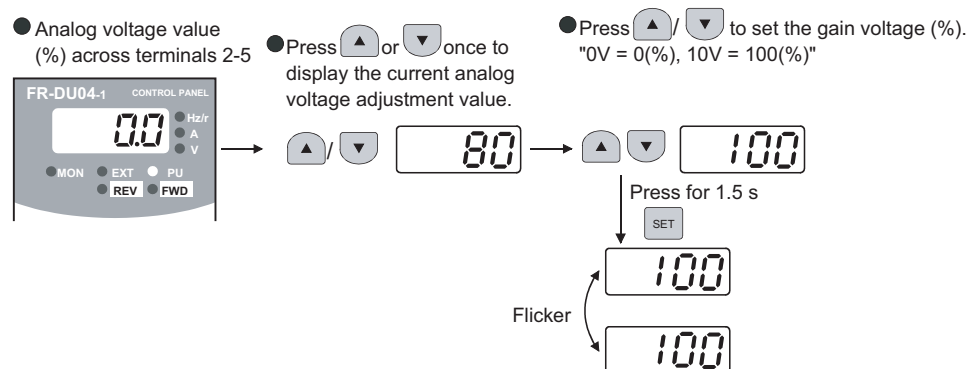

(6) Pressing **SET** shifts to the next parameter.

(7) Re-set the Pr. 79 "operation mode selection" value according to the operation mode being used.

**CAUTION**

1. Changing the Pr. 903 or Pr. 905 (gain adjustment) value will not change the Pr. 20 "acceleration/ deceleration reference speed" value. (Refer to page 78 for Pr. 20.) The input of terminal 1 (speed setting auxiliary input) is added to the speed setting signal.
2. For the operating procedure using the parameter unit (FR-PU04V), refer to the FR-PU04V instruction manual.
3. When applying voltage for calibration, the difference of the set input voltage of bias and gain should be 5% or more. If the difference is 5% or less, a setting error will occur.

**⚠ CAUTION**

⚠ Take care when setting any value other than "0" as the bias speed at 0V. Even if a speed command is not given, merely turning on the start signal will start the motor at the preset speed.

**Related parameters**

- Pr. 20 "acceleration/deceleration reference speed" (Refer to page 78.)
- Pr. 79 "operation mode selection" (Refer to page 117.)

● **Analog input offset adjustment**

When speed command by analog input is set, the range where the motor remains stop is created to prevent malfunction at very slow speed.

Parameter	Name	Factory setting	Setting Range	Remarks
849	Analog input offset adjustment	100%	0 to 200%	Pr. 77 = 801

Setting Pr. 849 provides speed command by analog input (terminal 2 or terminal 6 (FR-V5AX)) with offset and avoids speed command to be given due to noise under 0 speed command.

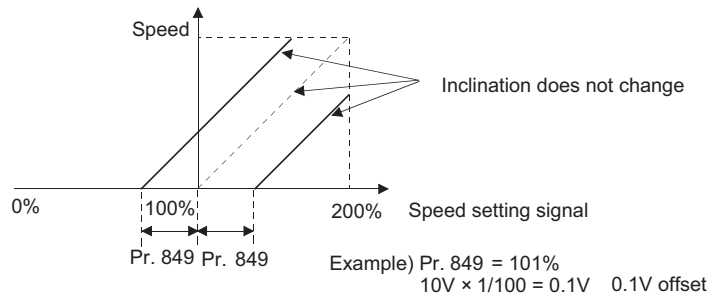

**3.42 Additional function (Pr. 990)**

**3.42.1 PU buzzer control (Pr. 990 speed torque position )**

You can make the buzzer "beep" when you press any key of the control panel or parameter unit.

Parameter	Name	Factory Setting	Setting Range	Remarks
990	PU buzzer control	1	0, 1	0: Without beep, 1: With beep   Extended mode

# MEMO

# 4

# SPECIFICATIONS

---

This chapter explains the "specifications" for use of this product. Always read this instructions before use.

---

<b>4.1</b>	<b>Model specifications .....</b>	<b>196</b>
<b>4.2</b>	<b>Common specifications.....</b>	<b>199</b>
<b>4.3</b>	<b>Outline dimension drawings .....</b>	<b>200</b>

1

2

3

4

## 4.1 Model specifications

### ● 200V class (for use with the Mitsubishi dedicated motor [SF-V5RU (1500r/min series)])

Type FR-V520-□□K	1.5	2.2	3.7	5.5	7.5	11	15	18.5	22	30	37	45	55	
Applied motor capacity (kW)	1.5	2.2	3.7	5.5	7.5	11	15	18.5	22	30	37	45	55	
Output	Rated capacity (kVA) (Caution 1)	3.1	4.5	6.9	9.8	13.0	18.7	25.2	30.4	35.8	43.8	58.1	68.5	91.0
	Rated current (A)	9.0	13.0	20.0	28.5	37.5	54	72.8	88	103.5	126.5	168	198	264
	Overload current rating (Caution 2)	150% 60s, 200% 0.5s (inverse-time characteristics)												
	Regenerative braking torque	100% torque/3%ED (Caution 3) (Caution 7)			100% torque/2%ED (Caution 3) (Caution 7)		20% torque/continuous (Caution 7)							
	Max. value/permissible duty													
Power supply	Rated input AC voltage, frequency	Three-phase, 200V to 220V 50Hz, 200 to 240V 60Hz						Three-phase, 200 to 220V 50Hz, 200 to 230V 60Hz						
	Permissible AC voltage fluctuation	170 to 242V 50Hz, 170 to 264V 60Hz						170 to 242V 50Hz, 170 to 253V 60Hz						
	Permissible frequency fluctuation	±5%												
	Instantaneous voltage drop immunity	Operation continues at 165V or higher voltage. If the rated voltage drops to lower than 165V, 15ms operation continues.												
	Power supply capacity (kVA) (Caution 4)	5.0	6.5	10	14	19	23	33	39	48	57	77	90	123
Protective structure (JEM 1030)	Enclosed type (IP20) (Caution 5)						Open type (IP00)							
Cooling system	Forced air cooling													
Approx. mass (kg)	3.5	3.5	6.0	6.0	6.0	14.0	14.0	21.0	30.0	40.0	40.0	55.0	58.0	
Dedicated motor	Motor type (Caution 8)	SF-V5RU 1K	SF-V5RU 2K	SF-V5RU 3K	SF-V5RU 5K	SF-V5RU 7K	SF-V5RU 11K	SF-V5RU 15K	SF-V5RU 18K	SF-V5RU 22K	SF-V5RU 30K	SF-V5RU 37K	SF-V5RU 45K	SF-V5RU 55K
	Rated output (kW)	1.5	2.2	3.7	5.5	7.5	11	15	18.5	22	30	37	45	55
	Rated torque (N·m)	9.55	14.1	23.6	35.0	47.7	70.0	95.5	118	140	191	235	286	350
	Maximum torque 150% 60s (N·m)	14.3	21.1	35.4	52.4	71.6	105	143	176	211	287	353	429	525
	Rated speed (r/min)	1500												
	Maximum speed (r/min)	3000 (Caution 6)												2400
	Frame No.	90L	100L	112M	132S	132M	160M	160L	180M	180M	200L	200L	200L	225S
	Moment of inertia J (X10 <sup>-4</sup> kg·m <sup>2</sup> )	67.5	105	175	275	400	750	875	1725	1875	3250	3625	3625	6850
	Noise (Caution 11)	75dB or less									80dB or less			85dB or less
	Cooling fan (with thermal protector)	Voltage	Single-phase 200V/50Hz Single-phase 200 to 230V/60Hz						Three-phase 200V/50Hz Three-phase 200 to 230V/60Hz					
		Input (50Hz/60Hz) (Caution 9)	36/55W (0.26/0.32A)			22/28W (0.11/0.13A)		55/71W (0.37/0.39A)			100/156W (0.47/0.53A)			85/ 130W (0.46/ 0.52A)
	Ambient temperature, humidity	-10 to +40°C (non-freezing), 90%RH or less (non-condensing)												
	Structure (Protective structure)	Totally enclosed forced draft system (Motor: IP44, cooling fan: IP23S) (Caution 10)												
	Detector	Encoder 2048P/R, A phase, B phase, Z phase +12VDC power supply												
	Equipment	Encoder, thermal relay protector, fan												
Heat resistance class	F													
Vibration rank	V10													
Approx. weight (kg)	24	33	41	52	62	99	113	138	160	238	255	255	320	
Dedicated Encoder cable	Resolution	2048 pulse/rev												
	Power supply voltage	12VDC±10%												
	Current consumption	90mA												
	Output signal form	A, B phases (90° phase shift) Z phase: 1 pulse/rev												
	Output circuit	Complimentary (constant voltage output matched by emitter follow)												
Output voltage	"H" level: Power supply voltage 9V or more (I <sub>OH</sub> : -20mA), "L" level: Power supply voltage 3V or less (I <sub>OL</sub> : 20mA)													

### CAUTION

- The rated output capacity indicated assumes that the output voltage is 200V.
- The % value of the overload current rating indicated is the ratio of the overload current to the inverter's rated output current. For repeated duty, allow time for the inverter and motor to return to or below the temperatures under 100% load.
- The short-time rating is 5s.
- The power supply capacity varies with the value of the power supply side inverter impedance (including those of the input reactor and cables).
- Open type (IP00) when the plug-in option is fitted after removal of the option wiring port cover.
- You can run the 3.7kW or less dedicated motor at the maximum speed of 3600r/min, consult us when you want to run the motor at higher than 3000r/min.
- With the dedicated external brake resistor FR-ABR (option), the 1.5K to 7.5K and 11K to 15K will achieve the performance of 100% torque/10%ED and 100% torque/6%ED respectively.
- If the motor is one rank lower in capacity than the inverter, it can be used by setting Pr. 80 "motor capacity" and Pr. 81 "number of motor poles". Other manufacturers' motors and special motors can be used by performing online auto tuning.
- Power (current) at 50Hz/60Hz.
- Since a motor with brake has a window for gap check, the protective structure of both the cooling fan section and brake section is IP20. S of IP23S is an additional code indicating the condition that protection from water intrusion is established only when a cooling fan is not operating.
- The value when high carrier frequency is set (Pr. 72 = 6, Pr. 240 = 0).

● 400V class (for use with the dedicated motor [SF-V5RUH (1500r/min series)])

Type FR-V540-[]K	1.5	2.2	3.7	5.5	7.5	11	15	18.5	22	30	37	45	55	
<b>Inverter</b>														
Applied motor capacity (kW)	1.5	2.2	3.7	5.5	7.5	11	15	18.5	22	30	37	45	55	
Output	Rated capacity (kVA) (Caution 1)	3.1	4.5	6.9	10.0	12.8	19.0	24.6	30.4	35.8	46.3	59.5	68.5	91.0
	Rated current (A)	4.5	6.5	10.0	14.5	18.5	27.5	35.5	44	51.8	67	86	99	132
	Overload current rating (Caution 2)	150% 60s, 200% 0.5s (inverse-time characteristics)												
	Regenerative braking Max. value/ permissible torque	100% torque/2%ED (Caution 3) (Caution 7)						20% torque/continuous (Caution 7)						
Power supply	Rated input AC voltage, frequency	Three-phase, 380V to 480V 50Hz/60Hz												
	Permissible AC voltage fluctuation	323 to 528V 50Hz/60Hz												
	Permissible frequency fluctuation	±5%												
	Instantaneous voltage drop immunity	Operation continues at 330V or higher voltage. If the rated voltage drops to lower than 330V, 15ms operation continues.												
	Power supply capacity (kVA)(Caution 4)	5.0	6.5	10	14	19	23	33	39	48	57	77	90	123
Protective structure (JEM 1030)	Enclosed type (IP20) (Caution 5)								Open type (IP00)					
Cooling system	Forced air cooling													
Approx. mass (kg)	3.5	3.5	6.0	6.0	14.0	14.0	14.0	14.0	24.0	35.0	35.0	50.0	52.0	
<b>Dedicated motor</b>														
Motor type (Caution 8)	SF-V5RU H1K	SSF-V5RU H2K	SF-V5RU H3K	SF-V5RU H5K	SF-V5RU H7K	SF-V5RU H11K	SF-V5RU H15K	SF-V5RU H18K	SF-V5RU H22K	SF-V5RU H30K	SF-V5RU H37K	SF-V5RU H45K	SF-V5RU H55K	
Rated output (kW)	1.5	2.2	3.7	5.5	7.5	11	15	18.5	22	30	37	45	55	
Rated torque (N·m)	9.55	14.1	23.6	35.0	47.7	70.0	95.5	118	140	191	235	286	350	
Maximum torque 150% 60s (N·m)	14.3	21.1	35.4	52.4	71.6	105	143	176	211	287	353	429	525	
Rated speed (r/min)	1500													
Maximum speed (r/min)	3000 (Caution 6)												2400	
Frame No.	90L	100L	112M	132S	132M	160M	160L	180M	180M	200L	200L	200L	225S	
Moment of inertia J (X10 <sup>-4</sup> kg·m <sup>2</sup> )	67.5	105	175	275	400	750	875	1725	1875	3250	3625	3625	6850	
Noise (Caution 11)	75dB or less									80dB or less			85dB or less	
Cooling fan (With thermal protector)	Voltage	Single-phase 200V/50Hz Single-phase 200 to 230V/60Hz					Three-phase 380 to 400V/50Hz Three-phase 400 to 460V/60Hz							
	Input (Caution 9)	36/55W (0.26/0.32A)			22/28W (0.11/0.13A)		55/71W (0.19/0.19A)			100/156W (0.27/0.3A)			85/ 130W (0.23/ 0.26A)	
Ambient temperature, humidity	-10 to +40°C (non-freezing), 90%RH or less (non-condensing)													
Structure (Protective structure)	Totally enclosed forced draft system (Motor: IP44, cooling fan: IP23S) (Caution 10)													
Detector	Encoder 2048P/R, A phase, B phase, Z phase +12VDC power supply													
Equipment	Encoder, thermal relay protector, fan													
Heat resistance class	F													
Vibration rank	V10													
Approx. weight (kg)	24	33	41	52	62	99	113	138	160	238	255	255	320	
<b>Dedicated encoder cable</b>														
Resolution	2048 pulse/rev													
Power supply voltage	12VDC±10%													
Current consumption	90mA													
Output signal form	A, B phases (90° phase shift) Z phase: 1 pulse/rev													
Output circuit	Complimentary (constant voltage output matched by emitter follow)													
Output voltage	"H" level: Power supply voltage 9V or more (I <sub>OH</sub> : -20mA), "L" level: Power supply voltage 3V or less (I <sub>OL</sub> : 20mA)													

CAUTION

- The rated output capacity indicated assumes that the output voltage is 400V.
- The % value of the overload current rating indicated is the ratio of the overload current to the inverter's rated output current. For repeated duty, allow time for the inverter and motor to return to or below the temperatures under 100% load.
- The short-time rating is 5s.
- The power supply capacity varies with the value of the power supply side inverter impedance (including those of the input reactor and cables).
- Open type (IP00) when the plug-in option is fitted after removal of the option wiring port cover.
- You can run the 3.7kW or less dedicated motor at the maximum speed of 3600r/min, consult us when you want to run the motor at higher than 3000r/min.
- With the dedicated external brake resistor FR-ABR-H (option), the 1.5K to 7.5K and 11K to 15K will achieve the performance of 100% torque/10%ED and 100% torque/6%ED respectively.
- If the motor is one rank lower in capacity than the inverter, it can be used by setting Pr. 80 "motor capacity" and Pr. 81 "number of motor poles". Other manufacturers' motors and special motors can be used by performing online auto tuning.
- Power (current) at 50Hz/60Hz.
- Since a motor with brake has a window for gap check, the protective structure of both the cooling fan section and brake section is IP20. S of IP23S is an additional code indicating the condition that protection from water intrusion is established only when a cooling fan is not operating.
- The value when high carrier frequency is set (Pr. 72 = 6, Pr. 240 = 0).

## Model specifications

### ● Combination with a vector control dedicated motor

Refer to the table below when using with a vector control dedicated motor.

#### • Combination with the SF-V5RU

Voltage		200V class			400V class		
Rated speed		1500r/min					
Base frequency		50Hz					
Maximum speed		3000r/min					
Motor capacity	Motor frame number	Motor type	Inverter type	Motor frame number	Motor type	Inverter type	
1.5kW	90L	SF-V5RU1K	FR-V520-1.5K	90L	SF-V5RUH1K	FR-V540-1.5K	
2.2kW	100L	SF-V5RU2K	FR-V520-2.2K	100L	SF-V5RUH2K	FR-V540-2.2K	
3.7kW	112M	SF-V5RU3K	FR-V520-3.7K	112M	SF-V5RUH3K	FR-V540-3.7K	
5.5kW	132S	SF-V5RU5K	FR-V520-5.5K	132S	SF-V5RUH5K	FR-V540-5.5K	
7.5kW	132M	SF-V5RU7K	FR-V520-7.5K	132M	SF-V5RUH7K	FR-V540-7.5K	
11kW	160M	SF-V5RU11K	FR-V520-11K	160M	SF-V5RUH11K	FR-V540-11K	
15kW	160L	SF-V5RU15K	FR-V520-15K	160L	SF-V5RUH15K	FR-V540-15K	
18.5kW	180M	SF-V5RU18K	FR-V520-18.5K	180M	SF-V5RUH18K	FR-V540-18.5K	
22kW	180M	SF-V5RU22K	FR-V520-22K	180M	SF-V5RUH22K	FR-V540-22K	
30kW	200L*2	SF-V5RU30K	FR-V520-30K	200L*2	SF-V5RUH30K	FR-V540-30K	
37kW	200L*2	SF-V5RU37K	FR-V520-37K	200L*2	SF-V5RUH37K	FR-V540-37K	
45kW	200L*2	SF-V5RU45K	FR-V520-45K	200L*2	SF-V5RUH45K	FR-V540-45K	
55kW	225S*1	SF-V5RU55K	FR-V520-55K	225S*1	SF-V5RUH55K	FR-V540-55K	

#### • Combination with the SF-V5RU1, 3, 4 and SF-THY

		SF-V5RU□1 (1:2)			SF-V5RU□3 (1:3)			SF-V5RU□4 (1:4)		
Voltage		200V class								
Rated speed		1000r/min			1000r/min			500r/min		
Base frequency		33.33Hz			33.33Hz			16.6Hz		
Maximum speed		2000r/min			3000r/min			2000r/min		
Motor capacity	Motor frame number	Motor type	Inverter type	Motor frame number	Motor type	Inverter type	Motor frame number	Motor type	Inverter type	
1.5kW	100L	SF-V5RU1K1	FR-V520-1.5K	112M	SF-V5RU1K3	FR-V520-2.2K	132M	SF-V5RU1K4	FR-V520-2.2K	
2.2kW	112M	SF-V5RU2K1	FR-V520-2.2K	132S	SF-V5RU2K3	FR-V520-2.2K	160M	SF-V5RU2K4	FR-V520-3.7K	
3.7kW	132S	SF-V5RU3K1	FR-V520-3.7K	132M	SF-V5RU3K3	FR-V520-3.7K	160L	SF-V5RU3K4	FR-V520-5.5K	
5.5kW	132M	SF-V5RU5K1	FR-V520-5.5K	160M	SF-V5RU5K3	FR-V520-5.5K	180L	SF-V5RU5K4	FR-V520-7.5K	
7.5kW	160M	SF-V5RU7K1	FR-V520-7.5K	160L	SF-V5RU7K3	FR-V520-11K	200L	SF-V5RU7K4	FR-V520-11K	
11kW	160L	SF-V5RU11K1	FR-V520-11K	180M	SF-V5RU11K3	FR-V520-15K	225S	SF-V5RU11K4	FR-V520-15K	
15kW	180M	SF-V5RU15K1	FR-V520-15K	180L	SF-V5RU15K3	FR-V520-15K	225S	SF-V5RU15K4	FR-V520-18.5K	
18.5kW	180L	SF-V5RU18K1	FR-V520-18.5K	200L	SF-V5RU18K3	FR-V520-22K	—	—	—	
22kW	200L	SF-V5RU22K1	FR-V520-22K	200L	SF-V5RU22K3	FR-V520-22K	—	—	—	
30kW	200L*3	SF-V5RU30K1	FR-V520-30K	225S*1	SF-V5RU30K3	FR-V520-37K	—	—	—	
37kW	225S	SF-V5RU37K1	FR-V520-37K	—	—	—	—	—	—	
45kW	—	—	—	—	—	—	—	—	—	
55kW	—	—	—	—	—	—	—	—	—	

400V class of SF-V5RU1, 3, 4 are developed upon receipt of order.

\*1 The maximum speed is 2400r/min.

\*2 80% output in the high-speed range. (The output is reduced when the speed is 2400r/min or more.)

\*3 90% output in the high-speed range. (The output is reduced when the speed is 1000r/min or more.)

## 4.2 Common specifications

Control specifications	Control method		Soft-PWM control or high carrier frequency sine-wave PWM control can be selected. Vector control or V/F control can be selected.		
	Control mode		Speed control torque control, position control		
	Speed setting resolution	Analog input	0.03% of the maximum set speed		
		Digital input	0.003% to the maximum setting (minimum setting 0.1r/min)		
	Acceleration/deceleration time		0 to 3600s (0.1s increments)		
	Acceleration/deceleration pattern		Linear, S pattern (3 types) or backlash measures acceleration/deceleration can be selected.		
Torque limit level		Torque limit value can be set (0 to 400% variable)			
Input signals	Analog setting signal	Terminal No.	Setting Range	Speed Control	Torque Control
		2	0 to 10V (resolution 0.03%)	Main speed setting	Speed limit
		1	0 to ±10V (resolution 0.05%)	Auxiliary speed setting/magnetic flux command/regenerative torque limit	Speed limit compensation/magnetic flux command/forward/reverse rotation speed limit (analog polarity switchover speed limit)
	Option (FR-V5AX)	6	0 to ±10V (resolution 0.003%)	Main speed setting (at this time, terminal 2 is invalid)/torque limit	Speed limit (at this time, terminal 2 is invalid)/Torque command (at this time, terminal 3 is invalid)
	Contact signal	3 fixed function terminals		Forward rotation command, alarm reset, external thermal relay	
		5 function terminals		Selection can be made from reverse rotation command, multi-speed setting (max. 15 speeds), remote setting, jog operation (Caution 1), second function selection, third function selection, output stop, start signal self-holding, pre-excitation, control mode switchover, torque limit selection, start time tuning, S pattern switchover, PID control terminal, orientation command, break opening completion signal, PU operation/external operation switchover, torque bias selection 1, torque bias selection 2, P control selection, servo on, HC connection, and PU/external interlock.	
Output signals	Contact signal	1 changeover contact (230VAC 0.3A, 30VDC 0.3A)		Selection can be made from inverter running, inverter running 2, up to speed, instantaneous power failure (undervoltage), speed detection, second speed detection, third speed detection, PU operation mode, overload warning, regenerative brake prealarm, electronic thermal relay function prealarm, output current detection, zero current detection, PID lower limit, PID upper limit, PID forward/reverse rotation output, operation ready, operation ready 2, brake opening request, fan fault output, heatsink overheat prealarm, orientation in-position, forward rotation output, reverse rotation output, low speed output, torque detection, regenerative status output, minor fault output, minor fault output 2, alarm output, maintenance timer output, start time tuning completion, remote output, output speed detection, second (third) output speed detection, in-position and trace status.	
		Open collector signal		3 multi-function terminals	
	Option (FR-V5AY)		3 multi-function terminals		Selection can be made from speed, output current, output voltage, preset speed, output frequency, motor torque, converter output voltage, regenerative brake duty, electronic thermal relay function load factor, output current peak value, converter output voltage peak value, load meter, motor excitation current, motor output, reference voltage output, torque command, torque current command and torque monitoring.
	Option (FR-V5AM)		1 multi-function terminal		
	Option (FR-A5AY)		7 multi-function terminals		
	Analog output		0 to ±10V 12 bits ×1CH 0 to 10V 12 bits ×1CH		Selection can be made from speed, output current, output voltage, preset speed, output frequency, motor torque, converter output voltage, regenerative brake duty, electronic thermal relay function load factor, output current peak value, converter output voltage peak value, load meter, motor excitation current, motor output, reference voltage output, torque command, torque current command and torque monitoring.
Option (FR-A5AY)		0 to 10V 10 bits × 1CH 0 to 20mA 10 bits × 1CH			
Encoder pulse output option (FR-V5AY)		A phase, B phase, Z phase (A and B phases can be divided) Open collector/differential line driver.			
Operational functions					
Maximum/minimum speed setting, speed jump, external thermal relay input selection, polarity reversible operation, override function, automatic restart after instantaneous power failure operation, forward/reverse rotation prevention, operation mode selection, offline auto tuning function, online auto tuning function, easy gain tuning, computer link operation, remote setting, brake sequence, second function, third function, multi-speed operation, coasting to stop, power failure stop, PID control, speed feed forward, model adaptive speed control, master/slave, torque bias, 12-bit digital command (FR-A5AX option), 16-bit digital command (FR-A5AH option), pulse train input (FR-A5AP option), motor thermistor interface (FR-V5AX option)					
Display	Parameter unit (FR-DU04-1/FR-PU04V)		Selection can be made from speed, output current, output voltage, preset speed, output frequency, motor torque, converter output voltage, regenerative brake duty, electronic thermal relay function load factor, output current peak value, converter output voltage peak value, input terminal status (Caution 4), output terminal status (Caution 4), load meter, motor excitation current, position pulse, cumulative energization time, actual operation time, motor load factor, torque command, torque current command, feedback pulse, motor output, trace status.		
	Alarm definition		Alarm definition is displayed when protective function is activated. 8 past alarm definitions are stored. (Only 4 alarm definitions are displayed on the control panel.)		
Protective functions					
Overcurrent shut-off (during acceleration, deceleration, constant speed), regenerative overvoltage shut-off (acceleration, deceleration, constant speed), undervoltage, instantaneous power failure, overload shut-off (electronic thermal relay function), brake transistor alarm (Caution 2), earth (ground) fault current, power output short circuit (12/24VDC/control panel), stall prevention, external thermal relay, heatsink overheat, fan fault, option alarm, parameter error, PU disconnection, encoder no-signal, speed deviation large, overspeed, position error large, CPU error, encoder phase error, output phase failure, retry count excess, brake sequence error					
Environment	Ambient temperature		-10°C to +50°C(non-freezing)		
	Ambient humidity		90%RH or less (non-condensing)		
	Storage temperature (Caution 3)		-20°C to +65°C		
	Atmosphere		Indoor use. (No corrosive gas, flammable gas, oil mist, dust and dirt)		
Altitude, vibration		Maximum 1,000m above sea level, 5.9m/s <sup>2</sup> or less			

### CAUTION

- Jog operation may also be performed from the control panel (FR-DU04-1) or the parameter unit (FR-PU04V).
- Not provided for the FR-V520-18.5K to 55K, FR-V540-18.5K to 55K that do not have a built-in brake circuit.
- Temperature applicable for a short period in transit, etc.
- Not provided for the control panel (FR-DU04-1).



### 4.3 Outline dimension drawings

#### 4.3.1 Inverter outline dimension drawings

- FR-V520-1.5K, 2.2K
- FR-V540-1.5K, 2.2K

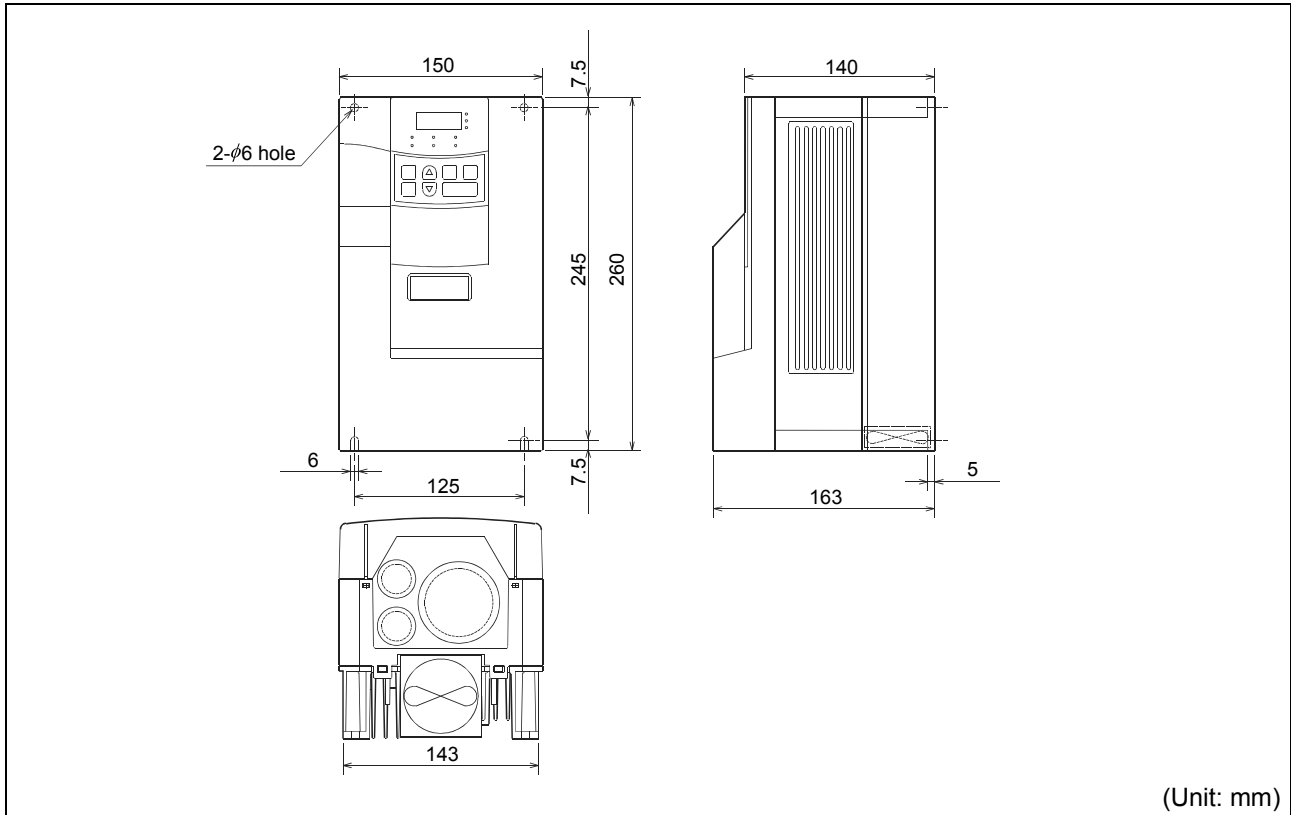

- FR-V520-3.7K, 5.5K, 7.5K
- FR-V540-3.7K, 5.5K

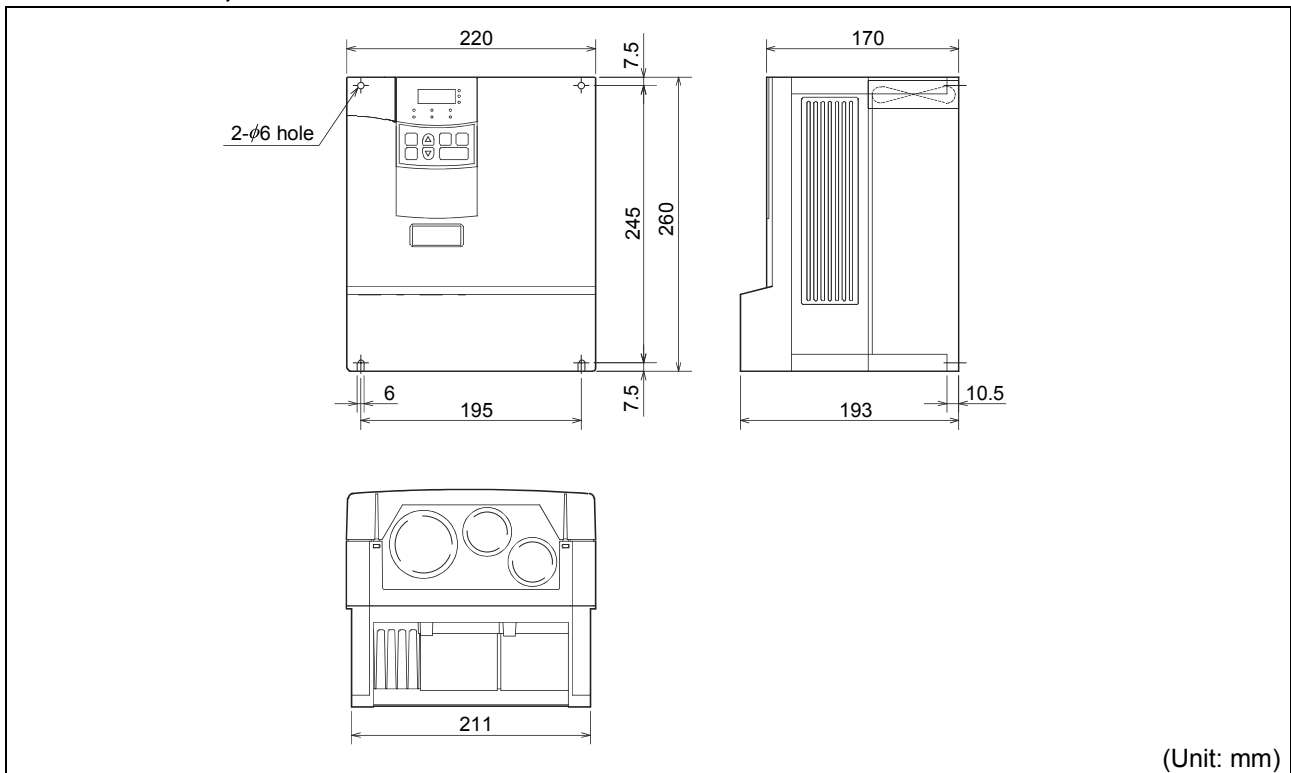

- FR-V520-11K, 15K
- FR-V540-7.5K, 11K, 15K, 18.5K

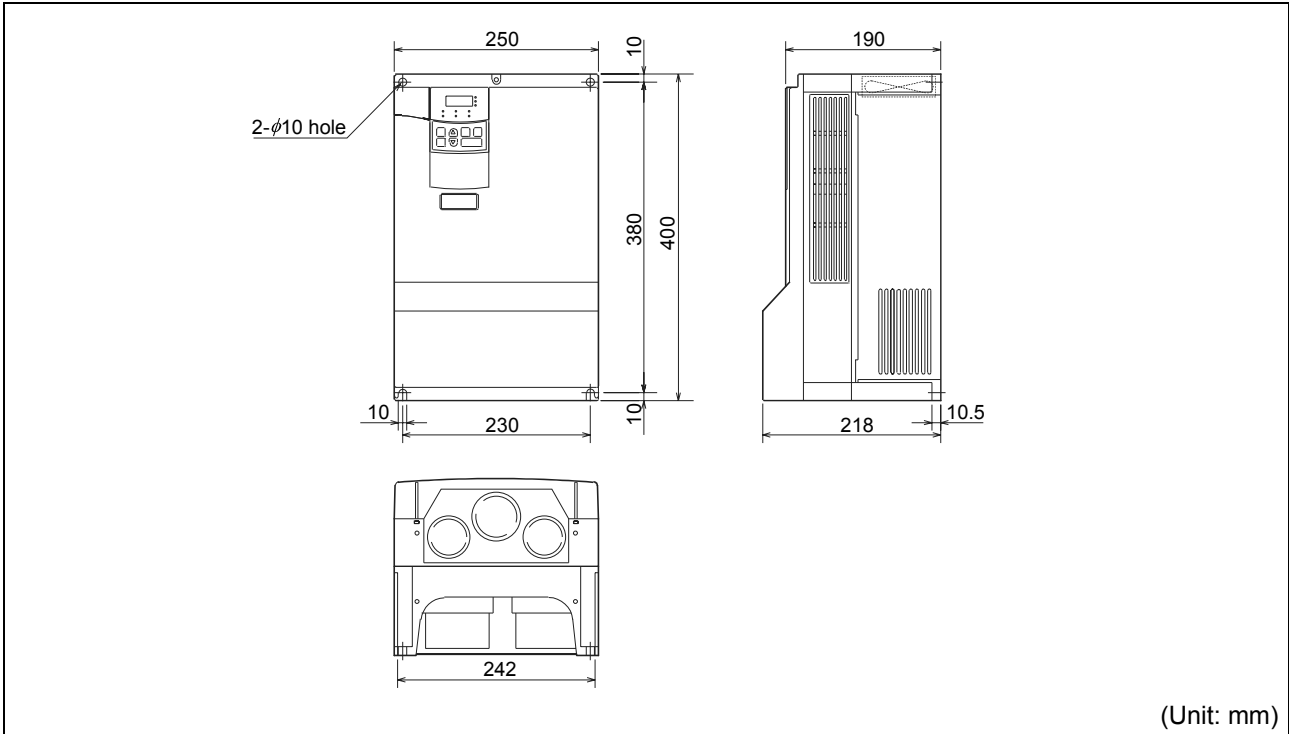

- FR-V520-18.5K

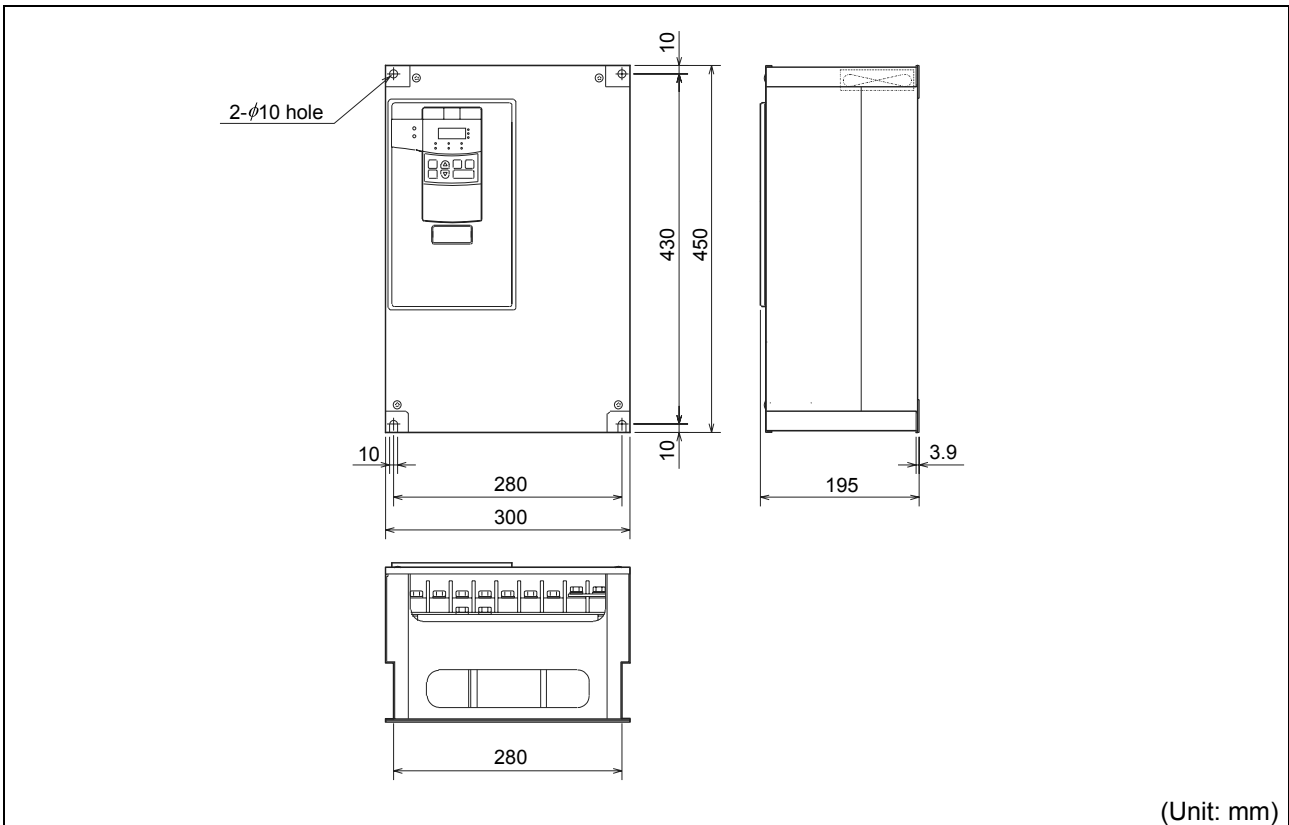

## Outline dimension drawings

- FR-V520-22K, 30K, 37K
- FR-V540-22K, 30K, 37K

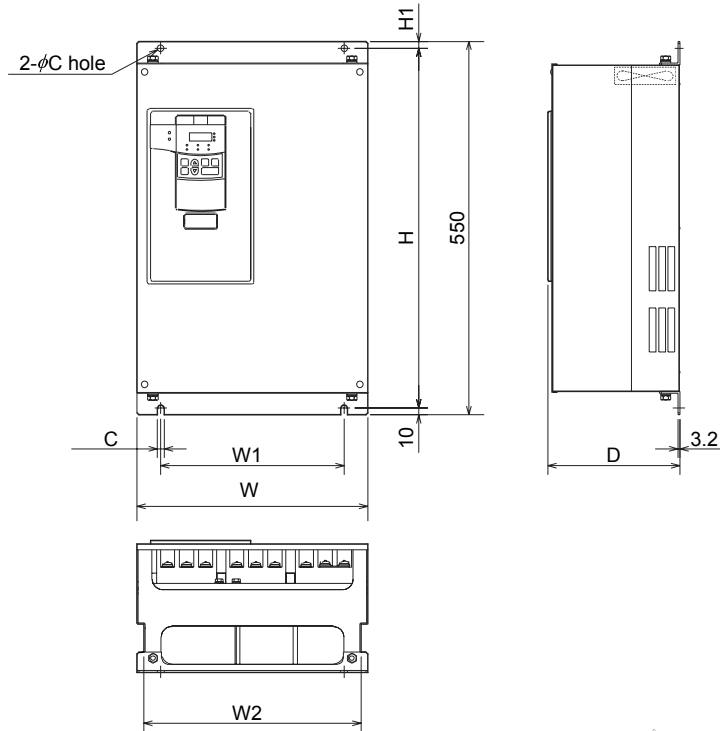

### ●200V class

Inverter Type	W	W1	W2	H	H1	D	C
FR-V520-22K	340	270	320	530	10	195	10
FR-V520-30K,37K	450	380	430	525	15	250	12

### ●400V class

Inverter Type	W	W1	W2	H	H1	D	C
FR-V540-22K	340	270	320	530	10	195	10
FR-V540-30K,37K	450	380	430	525	15	250	12

(Unit: mm)

- FR-V520-45K, 55K
- FR-V540-45K, 55K

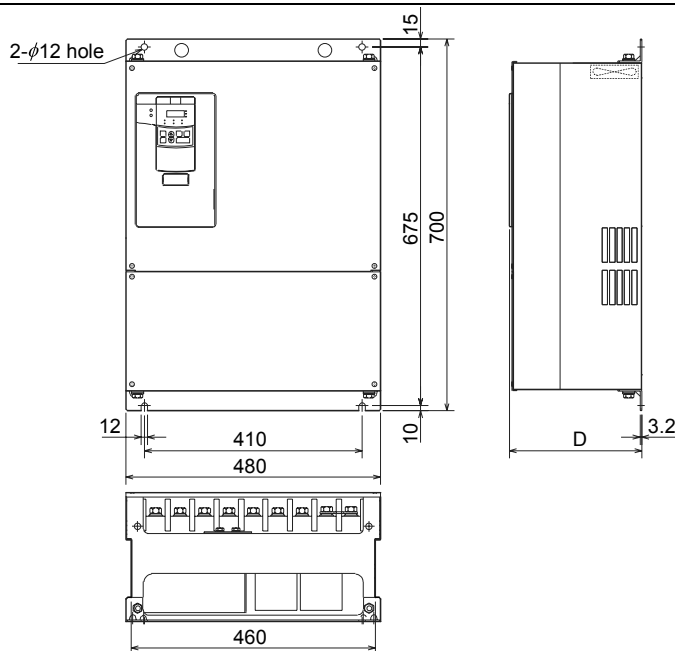

### ●200V class

Inverter Type	D
FR-V520-45K	250
FR-V520-55K	270

### ●400V class

Inverter Type	D
FR-V540-45K	250
FR-V540-55K	270

(Unit: mm)

**4.3.2 Control panel (FR-DU04-1) outline dimension drawings**

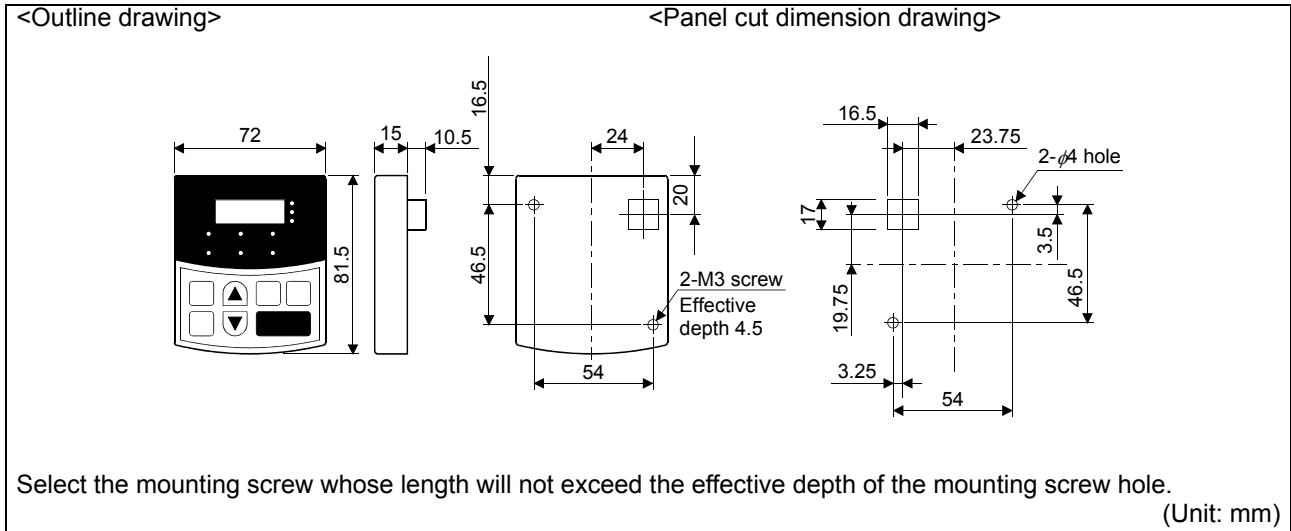

**4.3.3 Parameter unit (FR-PU04V) outline dimension drawings**

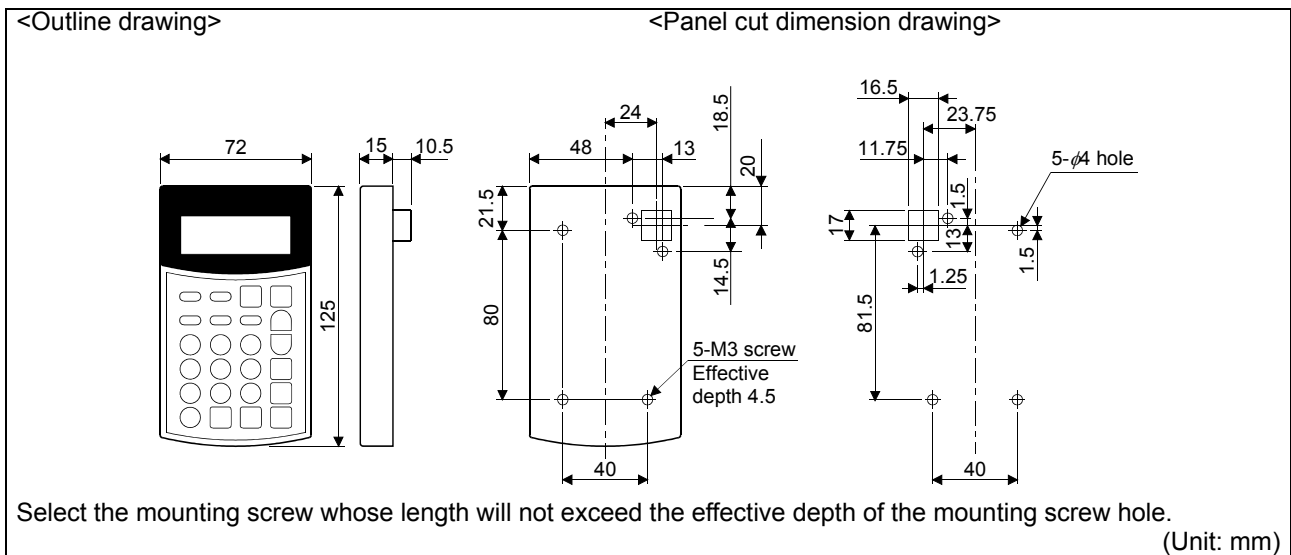

## Outline dimension drawings

### 4.3.4 Dedicated encoder cable outline dimension drawings

#### (FR-V5CBL)

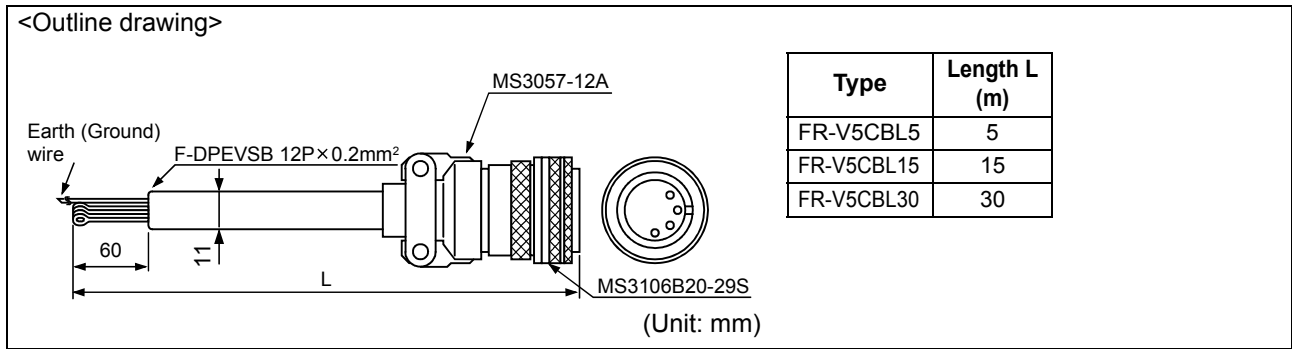

#### (FR-VCBL,FR-JCBL)

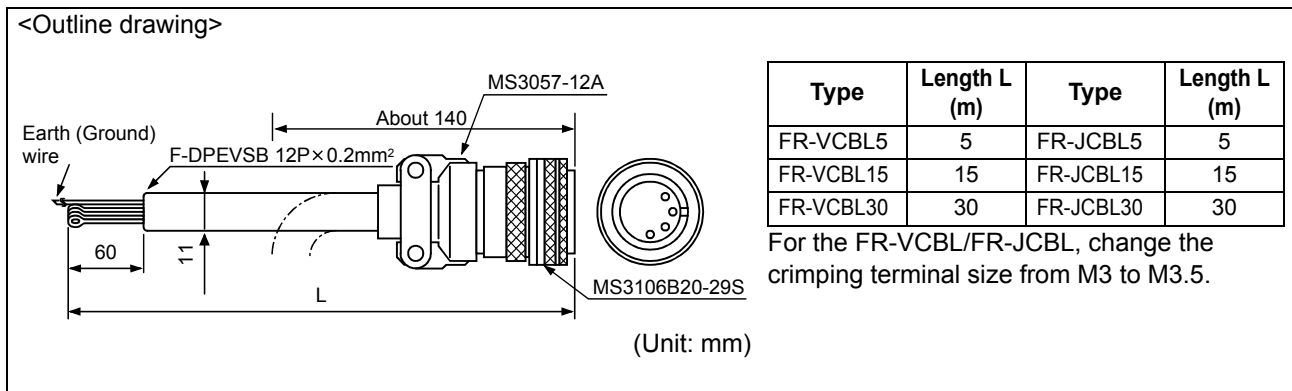

#### (1) Cable selection specifications

Wiring Distance	Dedicated Encoder Cable for Options	Cable Specification	
		Wiring 0.2mm <sup>2</sup> Cables	Using larger gauge cable
5m or less	FR-V5CBL5	2 parallels or more	0.4mm <sup>2</sup> or more
10m or less	FR-V5CBL15	2 parallels or more	
15m or less		4 parallels or more	0.75mm <sup>2</sup> or more
20m or less	FR-V5CBL30	4 parallels or more	
30m or less		6 parallels or more	
50m or less	Available on request, please consult us.	6 parallels or more	1.25mm <sup>2</sup> or more
100m or less			

If connection cables are not available, make cables according to the table above.

For the pin arrangement for the FR-VCBL/FR-JCBL, refer to page 39.

(2) Encoder connector (Manufactured by Japan Aviation Electronics Industries) for reference

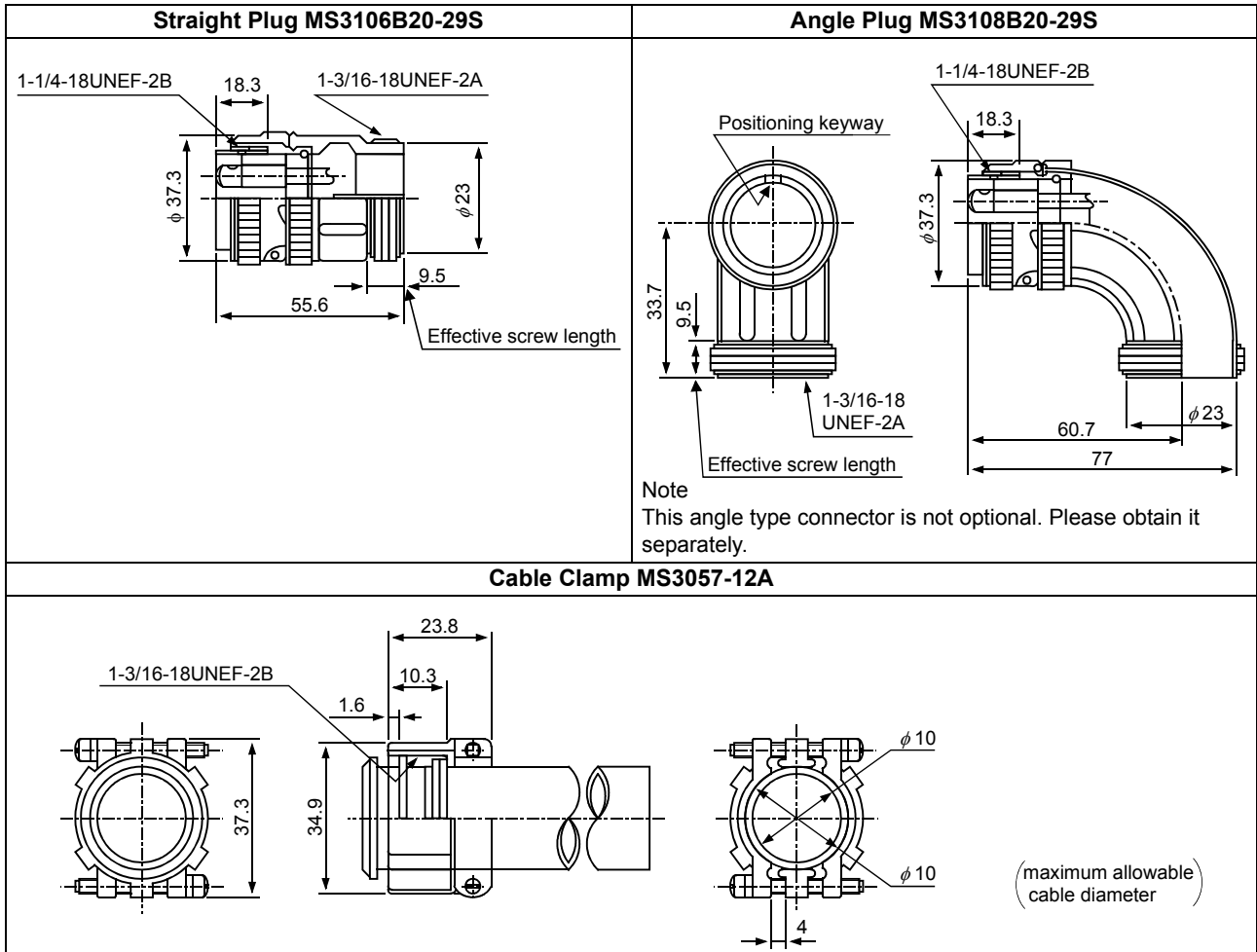

(3) Cable stresses

- (1) The way of clamping the cable must be fully considered so that flexing stress and cable's own weight stress are not applied to the cable connection.
- (2) In any application where the motor moves, do not subject the cable to excessive stress.
- (3) Avoid any probability that the cable sheath might be cut by sharp chips, rubbed by a machine corner or trampled over by workers or vehicles.
- (4) The reference value of dedicated encoder cable flexing life is shown on the right.  
When mounting the encoder on a machine where the motor will move, the flexing radius should be as large as possible.

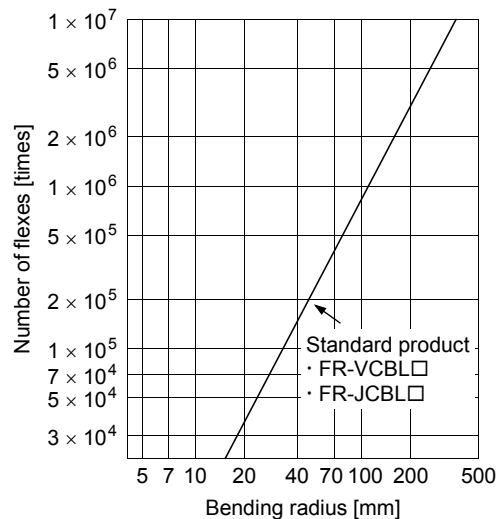

**CAUTION**  
This graph shows calculated values and not guaranteed values.

# Outline dimension drawings

## 4.3.5 Dedicated motor outline dimension drawings

### Dedicated motor outline dimension drawings (standard horizontal type)

**Frame Number 90L**  
**SF-V5RU(H) 1K**

**Frame Number 100L, 112M, 132S, 132M**  
**SF-V5RU(H) 2K, 3K, 5K, 7K**

**Frame Number 160M, 160L, 180M, 180L**  
**SF-V5RU(H) 11K, 15K, 18K, 22K**

**Frame Number 200L, 225S**  
**SF-V5RU(H) 30K, 37K, 45K, 55K**

Make sure to earth the earth terminal of the frame installation foot as well as the earth terminal in the terminal box.

### Dimensions table

(Unit: mm)

SF-V5RU K (kW)	SF-V5RU K1 (kW)	SF-V5RU K3 (kW)	SF-V5RU K4 (kW)	Frame No.	Mass (kg)	Motor																			Terminal Screw Size							
						A	B	C	D	E	F	H	I	KA	KG	KL(KP)	L	M	ML	N	XB	Q	QK	R	S	T	U	W	U,V,W	A,B,C	G1,G2	
1	—	—	—	90L	24	256.5	114	90	183.6	70	62.5	198	—	53	65	220(210)	425	175	—	150	56	—	—	188.5	24j6	7	4	8	M6	M4	M4	
2	1	—	—	100L	33	284	128	100	207	80	70	203.5	230	65	78	231	477	200	212	180	63	60	45	193	28j6	7	4	8	M6	M4	M4	
3	2	1	—	112M	41	278	135	112	228	95	70	226	253	69	93	242	478	230	242	180	70	60	45	200	28j6	7	4	8	M6	M4	M4	
5	3	2	—	132S	52	303	152	132	266	108	70	265	288	75	117	256	542	256	268	180	89	80	63	239	38k6	8	5	10	M6	M4	M4	
7	5	3	1	132M	62	322	171	132	266	108	89	265	288	94	117	256	580	256	268	218	89	80	63	258	38k6	8	5	10	M6	M4	M4	
11	7	5	2	160M	99	412	198	160	318	127	105	316	367	105	115	330	735	310	—	254	108	—	—	323	42k6	8	5	12	M8	M4	M4	
15	11	7	3	160L	113	434	220	160	318	127	127	316	367	127	115	330	779	310	—	298	108	—	—	345	42k6	8	5	12	M8	M4	M4	
18	—	—	—	180M	138	438.5	225.5	180	363	139.5	120.5	359	410	127	139	352	790	335	—	285	121	—	—	351.5	48k6	9	5.5	14	M8	M4	M4	
22	15	11	—	180L	160	457.5	242.5	180	363	139.5	139.5	359	410	146	139	352	828	335	—	323	121	—	—	370.5	55m6	10	6	16	M8	M4	M4	
30	—	—	7	200L	238	483.5	267.5	200	406	159	152.5	401	—	145	487	(546)	909	390	—	361	133	—	—	425.5	60m6	—	—	—	M10	M4	M4	
30, 45	22, 30	18, 22	—	200L	255	483.5	267.5	200	406	159	152.5	401	—	145	487	(592)	932	428	—	342	149	—	—	—	432	65m6	—	—	—	M10	M4	M4
55	37	30	11, 15	225S	320	500	277	225	446	178	143	446	—	145	533	(592)	932	428	—	342	149	—	—	—	432	65m6	—	—	—	M10	M4	M4

- Note) 1. Install the motor on the floor and use it with the shaft horizontal.  
 2. Leave an enough clearance between the fan suction port and wall to ensure adequate cooling. Also, check that the ventilation direction of a fan is from the opposite load side to the load side.  
 3. The size difference of top and bottom of the shaft center height is 0.5.  
 4. The 400V class motor has -H at the end of its type name.

Dedicated motor outline dimension drawings (standard horizontal type with brake)

### Frame Number 90L

SF-V5RU(H) 1KB

### Frame Number 100L, 112M, 132S, 132M

SF-V5RU(H) 2KB, 3KB, 5KB, 7KB

### Frame Number 160M, 160L, 180M, 180L

SF-V5RU(H) 11KB, 15KB, 18KB, 22KB

### Frame Number 200L, 225S

SF-V5RU(H) 30KB, 37KB, 45KB, 55KB

☆ indicates an inserting position of a bolt with hex head holes for manual opening.  
Make sure to earth the earth terminal of the frame installation foot as well as the earth terminal in the terminal box.

Dimensions table

(Unit: mm)

SF-V5RU KB (kW)	SF-V5RU KB1 (kW)	SF-V5RU KB3 (kW)	SF-V5RU KB4 (kW)	Frame No.	Mass (kg)	Motor																			Shaft End										Terminal Screw Size			
						A	B	C	D	E	F	G	H	I	J	KA	KD	KG	KL	KP	L	M	ML	N	X	XB	Z	Q	QK	R	S	T	U	W	U/VW	A8,G	G1,G2	B1,B2
1	—	—	—	90L	29	296.5	114	90	183.6	70	62.5	4	—	—	53	27	65	220	245	465	175	—	150	15	56	9	50	40	168.5	246	7	4	8	M6	M4	M4	M4	
2	1	—	—	100L	46	333.5	128	100	207	80	70	6.5	—	—	40	65	27	78	231	265	526.5	200	212	180	4	63	12	60	45	193	286	7	4	8	M6	M4	M4	M4
3	2	1	—	112M	53	355	135	112	228	95	70	6.5	—	—	40	69	27	93	242	290	555	230	242	180	4	70	12	60	45	200	286	7	4	8	M6	M4	M4	M4
5	3	2	—	132S	70	416	152	132	266	108	70	6.5	—	—	40	75	27	117	256	329	655	256	268	180	4	89	12	80	63	239	386	8	5	10	M6	M4	M4	M4
7	5	3	1	132M	80	435	171	132	266	108	89	6.5	—	—	40	94	27	117	256	329	693	256	268	218	4	89	12	80	63	258	386	8	5	10	M6	M4	M4	M4
11	7	5	2	160M	140	522.5	198	160	318	127	105	8	—	—	50	105	56	115	330	391	845.5	310	—	254	4	108	14.5	110	90	323	426	8	5	12	M8	M4	M4	M4
15	11	7	3	160L	155	544.5	220	160	318	127	127	8	—	—	50	127	56	115	330	391	889.5	310	—	298	4	108	14.5	110	90	345	426	8	5	12	M8	M4	M4	M4
18	—	—	—	180M	185	588.5	225.5	180	363	139.5	120.5	8	—	—	50	127	56	139	352	428	920	335	—	285	4	121	14.5	110	90	351.5	486	9	5.5	14	M8	M4	M4	M4
22	15	11	—	180M	215	588.5	225.5	180	363	139.5	139.5	8	—	—	50	146	56	139	352	428	958	335	—	323	4	121	14.5	110	90	370.5	556	10	6	16	M8	M4	M4	M4
—	18	15	5	180L	255	587.5	242.5	180	363	139.5	139.5	8	—	—	50	146	56	139	352	428	958	335	—	323	4	121	14.5	110	90	370.5	556	10	6	16	M8	M4	M4	M4
30	—	—	7	200L	305	644.5	267.5	200	406	159	152.5	11	—	—	70	145	90	487	—	546	1070	390	—	361	4	133	18.5	140	110	425.5	606	11	7	18	M10	M4	M4	M4
30, 45	22, 30	18, 22	—	200L	330	644.5	267.5	200	406	159	152.5	11	—	—	70	145	90	487	—	546	1070	390	—	361	4	133	18.5	140	110	425.5	606	11	7	18	M10	M4	M4	M4
55	37	30	11, 15	225S	395	659	277	225	446	178	143	11	—	—	70	145	90	533	—	592	1091	428	—	342	4	149	18.5	140	110	432	656	11	7	18	M10	M4	M4	M4

- Note) 1. Install the motor on the floor and use it with the shaft horizontal.  
 2. Leave an enough clearance between the fan suction port and wall to ensure adequate cooling.  
 Also, check that the ventilation direction of a fan is from the opposite load side to the load side.  
 3. The size difference of top and bottom of the shaft center height is  $\pm 0.5$ .  
 4. The 400V class motor has -H at the end of its type name.  
 5. Since a brake power device is a stand-alone, install it inside the enclosure.  
 (This device should be arranged at the customer side.)

SPECIFICATIONS



# Outline dimension drawings

## Dedicated motor outline dimension drawings (flange type)

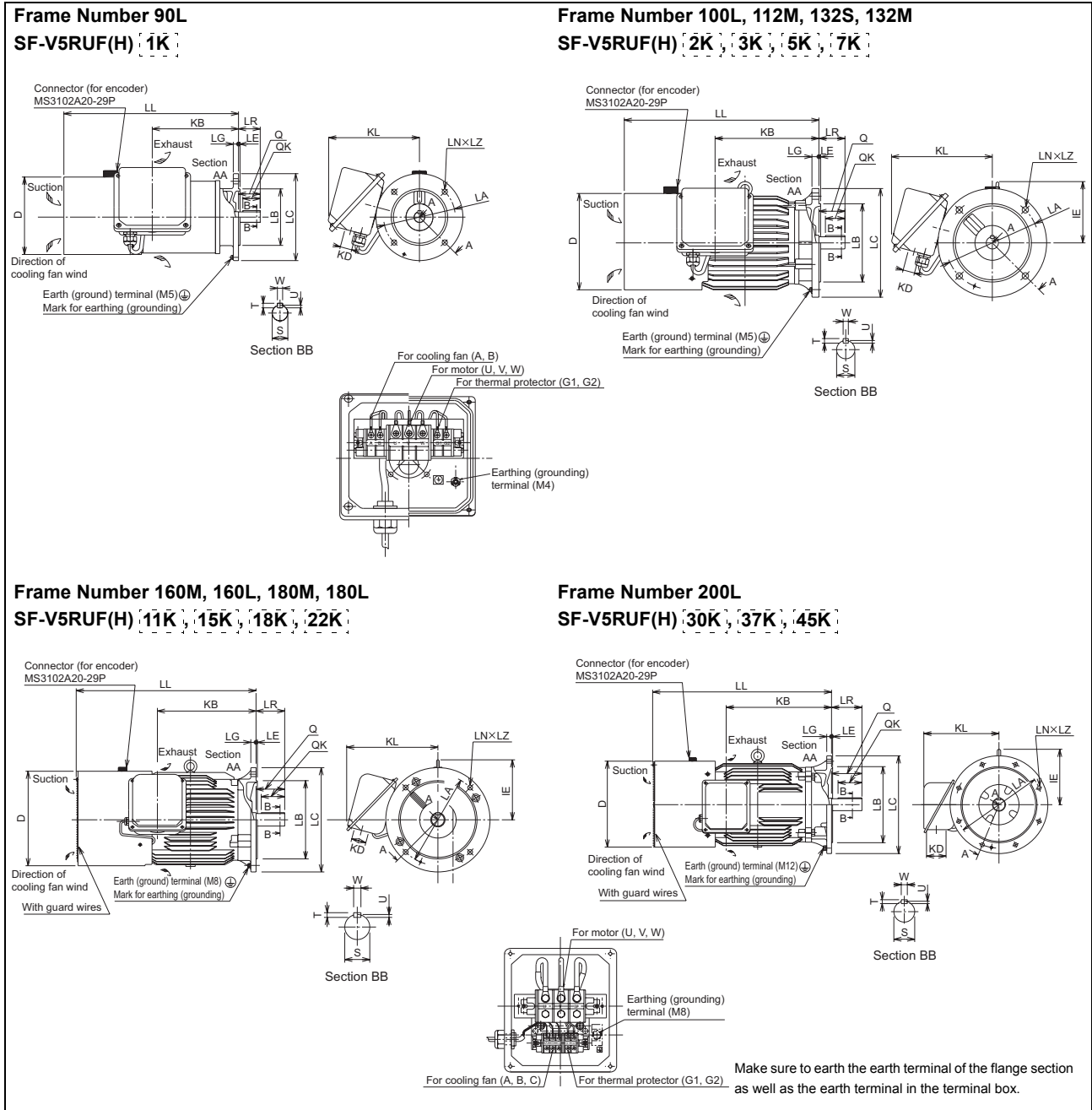

### Dimensions table

(Unit: mm)

SF-V5RU KF (kW)	SF-V5RU KF1 (kW)	SF-V5RU KF3 (kW)	SF-V5RU KF4 (kW)	Flange Number	Frame No.	Mass (kg)	Motor																Shaft End					Terminal Screw Size		
							D	IE	KB	KD	KL	LA	LB	LC	LE	LG	LL	LN	LZ	LR	Q	QK	S	T	U	W	U,V,W	A,B,C	G1,G2	
1	—	—	—	FF165	90L	26.5	183.6	—	198.5	27	220	165	130j6	200	3.5	12	402	4	12	50	50	40	24j6	7	4	8	M6	M4	M4	
2	1	—	—	FF215	100L	37	207	130	213	27	231	215	180j6	250	4	16	432	4	14.5	60	60	45	28j6	7	4	8	M6	M4	M4	
3	2	1	—	FF215	112M	46	228	141	239	27	242	215	180j6	250	4	16	448	4	14.5	60	60	45	28j6	7	4	8	M6	M4	M4	
5	3	2	—	FF265	132S	65	266	156	256	27	256	265	230j6	300	4	20	484	4	14.5	80	80	63	38k6	8	5	10	M6	M4	M4	
7	5	3	1	FF265	132M	70	266	156	294	27	256	265	230j6	300	4	20	522	4	14.5	80	80	63	38k6	8	5	10	M6	M4	M4	
11	7	5	2	FF300	160M	110	318	207	318	56	330	300	250j6	350	5	20	625	4	18.5	110	110	90	42k6	8	5	12	M8	M4	M4	
15	11	7	3	FF300	160L	125	318	207	362	56	330	300	250j6	350	5	20	669	4	18.5	110	110	90	42k6	8	5	12	M8	M4	M4	
18	—	—	—	FF350	180M	160	363	230	378.5	56	352	350	300j6	400	5	20	690	4	18.5	110	110	90	48k6	9	5.5	14	M8	M4	M4	
22	15	11	—	FF350	180L	185	363	230	416.5	56	352	350	300j6	400	5	20	728	4	18.5	110	110	90	55m6	10	6	16	M8	M4	M4	
30	—	—	7	FF400	200L	270	406	255	485	90	346	400	350j6	450	5	22	823.5	8	18.5	140	140	110	60m6	11	7	18	M10	M4	M4	
37, 45	22, 30	18, 22	—	—	—	290	—	—	—	—	—	—	—	—	—	—	—	—	—	—	—	—	—	—	—	—	—	—	—	

- Note) 1. Install the motor on the floor and use it with the shaft horizontal.  
 For use under the shaft, the protection structure of the cooling fan is IP20.  
 2. Leave an enough clearance between the fan suction port and wall to ensure adequate cooling.  
 Also, check that the ventilation direction of a fan is from the opposite load side to the load side.  
 3. The size difference of top and bottom of the shaft center height is  $\pm 0.5$ .  
 4. The 400V class motor has -H at the end of its type name.

Dedicated motor outline dimension drawings (flange type with brake)

**Frame Number 90L**  
**SF-V5RUF(H) 1KB**

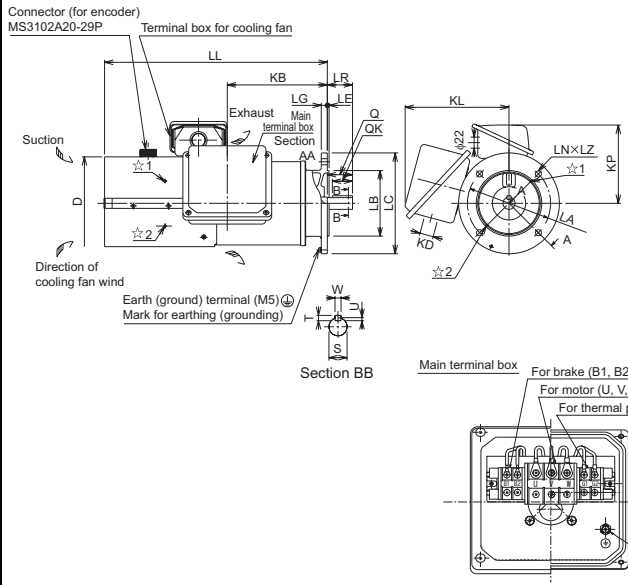

**Frame Number 100L, 112M, 132S, 132M**  
**SF-V5RUF(H) 2KB, 3KB, 5KB, 7KB**

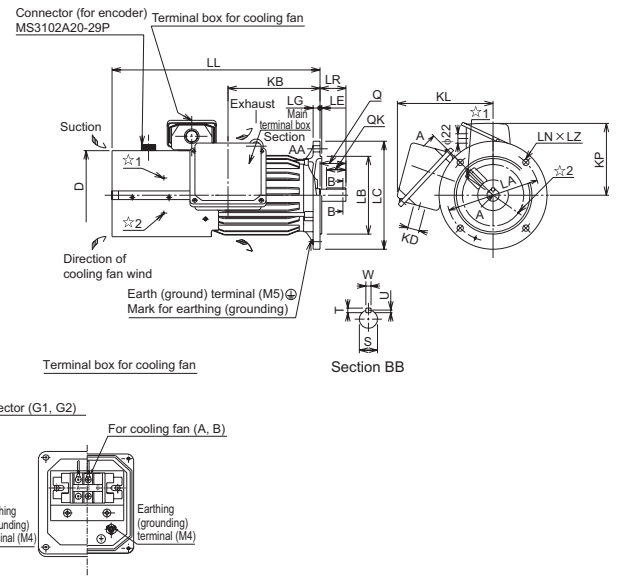

**Frame Number 160M, 160L**  
**SF-V5RUF(H) 11KB, 15KB**

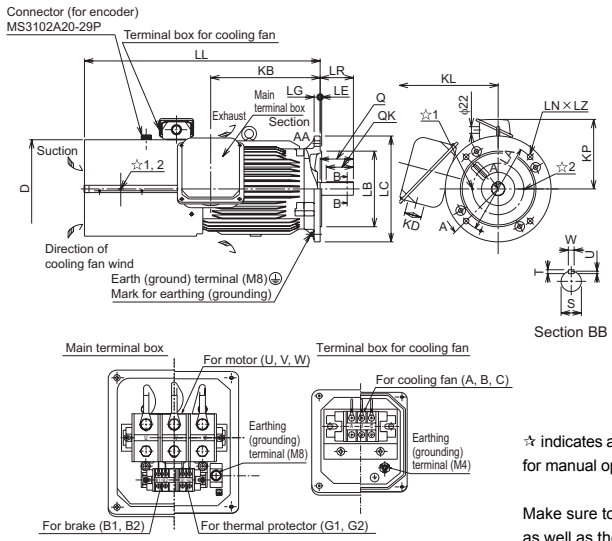

☆ indicates an inserting position of a bolt with hex head holes for manual opening.

Make sure to earth the earth terminal of the flange section as well as the earth terminal in the terminal box.

Dimensions table

(Unit: mm)

SF-V5RU KFB Output (kW)	SF-V5RU KFB1 Output (kW)	SF-V5RU KFB3 Output (kW)	SF-V5RU KFB4 Output (kW)	Flange Number	Frame No.	Mass (kg)	Motor													Shaft End					Terminal Screw Size					
							D	KB	KD	KL	KP	LA	LB	LC	LE	LG	LL	LN	LZ	LR	Q	QK	S	T	U	W	U,V,W	A,B,C	B1,B2	G1,G2
1	—	—	—	FF165	90L	31.5	183.6	198.5	27	220	155	165	130j6	200	3.5	12	442	4	12	50	50	40	24j6	7	4	8	M6	M4	M4	M4
2	1	—	—	FF215	100L	50	207	213	27	231	165	215	180j6	250	4	16	481.5	4	14.5	60	60	45	28j6	7	4	8	M6	M4	M4	M4
3	2	1	—	FF215	112M	58	228	239	27	242	178	215	180j6	250	4	16	525	4	14.5	60	60	45	28j6	7	4	8	M6	M4	M4	M4
5	3	2	—	FF265	132S	83	266	256	27	256	197	265	230j6	300	4	20	597	4	14.5	80	80	63	38k6	8	5	10	M6	M4	M4	M4
7	5	3	1	FF265	132M	88	266	294	27	256	197	265	230j6	300	4	20	635	4	14.5	80	80	63	38k6	8	5	10	M6	M4	M4	M4
11	7	5	2	FF300	160M	151	318	318	56	330	231	300	250j6	350	5	20	735.5	4	18.5	110	110	90	42k6	8	5	12	M8	M4	M4	M4
15	11	7	3	FF300	160L	167	318	362	56	330	231	300	250j6	350	5	20	779.5	4	18.5	110	110	90	42k6	8	5	12	M8	M4	M4	M4

- Note) 1. Install the motor on the floor and use it with the shaft horizontal.  
 For use under the shaft, the protection structure of the cooling fan is IP20.  
 2. Leave an enough clearance between the fan suction port and wall to ensure adequate cooling.  
 Also, check that the ventilation direction of a fan is from the opposite load side to the load side.  
 3. The size difference of top and bottom of the shaft center height is  $\pm 0.5$ .  
 4. The 400V class motor has -H at the end of its type name.  
 5. Since a brake power device is a stand-alone, install it inside the enclosure.  
 (This device should be arranged at the customer side.)

# MEMO



# APPENDICES

---

This chapter provides the "appendix" for use of this product. Always read this instructions before use.

---

<b>Appendix1</b>	<b>Setting a thermistor of a dedicated motor (SF-V5RU****T) (when used with the FR-V5AX) .....</b>	<b>212</b>
<b>Appendix2</b>	<b>Parameter Instruction Code List.....</b>	<b>213</b>
<b>Appendix3</b>	<b>SERIAL number check.....</b>	<b>220</b>

## **Appendix1 Setting a thermistor of a dedicated motor (SF-V5RU\*\*\*\*T) (when used with the FR-V5AX)**

---

When using a thermistor interface with the FR-V5AX connected, use Pr. 408 to select a motor type. It is factory set to "0" (SF-V5RU□□□□□T). Set this parameter according to the motor used.

<b>Parameter</b>	<b>Name</b>	<b>Factory setting Setting</b>	<b>Minimum Setting Increments</b>	<b>Setting Range</b>	<b>Definition</b>
408	Motor thermistor selection	0	1	0	SF-V5RU□□□□□T
				1	SF-V5RU□□□□□A

## Appendix2 Parameter Instruction Code List

Function	Parameter No.	Name	Instruction Code		Link Parameter Expansion Setting (Instruction code 7F/FF)
			Read	Write	
Basic functions	0	Torque boost (manual)	00	80	0
	1	Maximum speed (simple mode)	01	81	0
	2	Minimum speed (simple mode)	02	82	0
	3	Base frequency	03	83	0
	4	Multi-speed setting (high speed) (simple mode)	04	84	0
	5	Multi-speed setting (middle speed) (simple mode)	05	85	0
	6	Multi-speed setting (low speed) (simple mode)	06	86	0
	7	Acceleration time (simple mode)	07	87	0
	8	Deceleration time (simple mode)	08	88	0
Standard operation functions	9	Electronic thermal O/L relay	09	89	0
	10	DC injection brake operation speed	0A	8A	0
	11	DC injection brake operation time	0B	8B	0
	12	DC injection brake voltage	0C	8C	0
	13	Starting speed	0D	8D	0
	15	Jog speed setting	0F	8F	0
Operation selection functions	16	Jog acceleration/deceleration time	10	90	0
	17	MRS input selection	11	91	0
	19	Base frequency voltage	13	93	0
	20	Acceleration/deceleration reference speed	14	94	0
	21	Acceleration/deceleration time increments	15	95	0
	22	Torque limit level	16	96	0
	24	Multi-speed setting (speed 4)	18	98	0
	25	Multi-speed setting (speed 5)	19	99	0
	26	Multi-speed setting (speed 6)	1A	9A	0
	27	Multi-speed setting (speed 7)	1B	9B	0
	28	Multi-speed input compensation	1C	9C	0
	29	Acceleration/deceleration pattern	1D	9D	0
	30	Regenerative function selection	1E	9E	0
	31	Speed jump 1A	1F	9F	0
	32	Speed jump 1B	20	A0	0
	33	Speed jump 2A	21	A1	0
	34	Speed jump 2B	22	A2	0
35	Speed jump 3A	23	A3	0	
36	Speed jump 3B	24	A4	0	
Display function	37	Speed display	25	A5	0
Output terminal functions	41	Up-to-speed sensitivity	29	A9	0
	42	Speed detection	2A	AA	0
	43	Speed detection for reverse rotation	2B	AB	0
Second functions	44	Second acceleration/deceleration time	2C	AC	0
	45	Second deceleration time	2D	AD	0
Terminal assignment functions	50	Second speed detection	32	B2	0
Display functions	52	DU/PU main display data selection	34	B4	0
	53	PU level display data selection	35	B5	0
	54	DA1 terminal function selection	36	B6	0
	55	Speed monitoring reference	37	B7	0
	56	Current monitoring reference	38	B8	0
Automatic restart	57	Restart coasting time	39	B9	0
	58	Restart cushion time	3A	BA	0
Additional function	59	Remote setting function selection	3B	BB	0
Operation selection functions	60	Intelligent mode selection	3C	BC	0
	65	Retry selection	41	C1	0
	67	Number of retries at alarm occurrence	43	C3	0
	68	Retry waiting time	44	C4	0
	69	Retry count display erasure	45	C5	0
	70	Special regenerative brake duty	46	C6	0
	71	Applied motor	47	C7	0
	72	PWM frequency selection (simple mode)	48	C8	0
	73	Speed setting signal	49	C9	0
	75	Reset selection/disconnected PU detection/PU stop selection	4B	CB	0
	77	Parameter write disable selection (simple mode)	4D	CD (Caution)	0
	78	Reverse rotation prevention selection	4E	CE	0
	79	Operation mode selection (simple mode)	4F	CF (Caution)	0

## Parameter Instruction Code List

Function	Parameter No.	Name	Instruction Code		Link Parameter Expansion Setting (Instruction code 7F/FF)
			Read	Write	
Motor constants	80	Motor capacity	50	D0	0
	81	Number of motor poles	51	D1	0
	82	Motor excitation current (no load current)	52	D2	0
	83	Rated motor voltage	53	D3	0
	84	Rated motor frequency	54	D4	0
	90	Motor constant R1	5A	DA	0
	91	Motor constant R2	5B	DB	0
	92	Motor constant L1	5C	DC	0
	93	Motor constant L2	5D	DD	0
	94	Motor constant X	5E	DE	0
Third functions	95	Online auto tuning selection (simple mode)	5F	DF	0
	96	Auto tuning setting/status	60	E0	0
Third functions	110	Third acceleration/deceleration time	0A	8A	1
	111	Third deceleration time	0B	8B	1
Terminal assignment functions	116	Third speed detection	10	90	1
Communication functions	117	Communication station number	11	91	1
	118	Communication speed	12	92	1
	119	Stop bit length/data length	13	93	1
	120	Parity check presence/absence	14	94	1
	121	Number of communication retries	15	95	1
	122	Communication check time interval	16	96	1
	123	Waiting time setting	17	97	1
PID control	124	CR/LF selection	18	98	1
	128	PID action selection	1C	9C	1
	129	PID proportional band	1D	9D	1
	130	PID integral time	1E	9E	1
	131	Upper limit	1F	9F	1
	132	Lower limit	20	A0	1
Backlash	133	PID action set point for PU operation	21	A1	1
	134	PID differential time	22	A2	1
	140	Backlash acceleration stopping speed	28	A8	1
	141	Backlash acceleration stopping time	29	A9	1
Display functions	142	Backlash deceleration stopping speed	2A	AA	1
	143	Backlash deceleration stopping time	2B	AB	1
Display functions	144	Speed setting switchover	2C	AC	1
	145	PU display language selection	2D	AD	1
Current detection	150	Output current detection level	32	B2	1
	151	Output current detection period	33	B3	1
	152	Zero current detection level	34	B4	1
Sub functions	153	Zero current detection period	35	B5	1
	156	Stall prevention operation selection	38	B8	1
Display functions	157	OL signal output timer	39	B9	1
	158	DA2 terminal function selection	3A	BA	1
Automatic restart after instantaneous power failure	160	Extended function selection (simple mode)	00	80	2
	162	Automatic restart after instantaneous power failure selection	02	82	2
	163	First cushion time for restart	03	83	2
	164	First cushion voltage for restart	04	84	2
Initial monitor	165	Restart current limit level	05	85	2
	171	Actual operation hour meter clear	0B	8B	2
Terminal assignment functions	180	DI1 terminal function selection	14	94	2
	181	DI2 terminal function selection	15	95	2
	182	DI3 terminal function selection	16	96	2
	183	DI4 terminal function selection	17	97	2
	187	STR terminal function selection	1B	9B	2
	190	DO1 terminal function selection	1E	9E	2
	191	DO2 terminal function selection	1F	9F	2
Multi-speed operation	192	DO3 terminal function selection	20	A0	2
	195	A, B, C terminal function selection	23	A3	2
	232	Multi-speed setting (speed 8)	28	A8	2
	233	Multi-speed setting (speed 9)	29	A9	2
	234	Multi-speed setting (speed 10)	2A	AA	2
	235	Multi-speed setting (speed 11)	2B	AB	2
	236	Multi-speed setting (speed 12)	2C	AC	2
Sub functions	237	Multi-speed setting (speed 13)	2D	AD	2
	238	Multi-speed setting (speed 14)	2E	AE	2
	239	Multi-speed setting (speed 15)	2F	AF	2
Sub functions	240	Soft-PWM setting	30	B0	2
	244	Cooling fan operation selection	34	B4	2

Function	Parameter No.	Name	Instruction Code		Link Parameter Expansion Setting (Instruction code 7F/FF)
			Read	Write	
Stop selection function	250	Stop selection	3A	BA	2
Operation selection function	251	Output phase failure protection selection	3B	BB	2
Additional functions	252	Override bias	3C	BC	2
	253	Override gain	3D	BD	2
Power failure stop functions	261	Power failure stop selection	45	C5	2
	262	Subtracted speed at deceleration start	46	C6	2
	263	Subtraction starting speed	47	C7	2
	264	Power-failure deceleration time 1	48	C8	2
	265	Power-failure deceleration time 2	49	C9	2
	266	Power-failure deceleration time switchover speed	4A	CA	2
Brake sequence	278	Brake opening speed	56	D6	2
	279	Brake opening current	57	D7	2
	280	Brake opening current detection time	58	D8	2
	281	Brake operation time at start	59	D9	2
	282	Brake operation speed	5A	DA	2
	283	Brake operation time at stop	5B	DB	2
	284	Deceleration detection function selection	5C	DC	2
	285	Overspeed detection speed	5D	DD	2
Droop	286	Droop gain	5E	DE	2
	287	Droop filter time constant	5F	DF	2
	288	Droop function activation selection	60	E0	2
Digital input	300	BCD input bias	00	80	3
	301	BCD input gain	01	81	3
	302	Binary input bias	02	82	3
	303	Binary input gain	03	83	3
	304	Digital input and analog compensation input enable/disable selection	04	84	3
	305	Read timing operation selection	05	85	3
Analog output	306	Analog output signal selection	06	86	3
	307	Setting for zero analog output	07	87	3
	308	Setting for maximum analog output	08	88	3
	309	Analog output signal voltage/current switchover	09	89	3
	310	Analog meter voltage output selection	0A	8A	3
	311	Setting for zero analog meter voltage output	0B	8B	3
	312	Setting for maximum analog meter voltage output	0C	8C	3
Digital output	313	Y0 output selection	0D	8D	3
	314	Y1 output selection	0E	8E	3
	315	Y2 output selection	0F	8F	3
	316	Y3 output selection	10	90	3
	317	Y4 output selection	11	91	3
	318	Y5 output selection	12	92	3
	319	Y6 output selection	13	93	3
Relay output	320	RA1 output selection	14	94	3
	321	RA2 output selection	15	95	3
	322	RA3 output selection	16	96	3
Digital input	329	Digital input unit selection	1D	9D	3
Relay output	330	RA0 output selection	1E	9E	3
Communication	331	Communication station number	1F	9F	3
	332	Communication speed	20	A0	3
	333	Stop bit length	21	A1	3
	334	Parity check presence/absence	22	A2	3
	335	Number of communication retries	23	A3	3
	336	Communication check time interval	24	A4	3
	337	Waiting time setting	25	A5	3
	338	Operation command source	26	A6	3
	339	Speed command source	27	A7	3
	340	Link startup mode selection	28	A8	3
	341	CR/LF presence/absence selection	29	A9	3
	342	E <sup>2</sup> PROM write selection	2A	AA	3
	345	DeviceNet address (lower)	2D	AD	3
	346	DeviceNet baud rate (lower)	2E	AE	3
	347	DeviceNet address (higher)	2F	AF	3
	348	DeviceNet baud rate (higher)	30	B0	3



## Parameter Instruction Code List

Function	Parameter No.	Name	Instruction Code		Link Parameter Expansion Setting (Instruction code 7F/FF)
			Read	Write	
Orientation	350	Stop position command selection	32	B2	3
	351	Orientation switchover speed	33	B3	3
	356	Internal stop position command	38	B8	3
	357	In-position zone	39	B9	3
	359	Orientation encoder rotation direction	3B	BB	3
	360	External position command selection	3C	BC	3
	361	Position shift	3D	BD	3
	362	Orientation position loop gain	3E	BE	3
	369	Number of orientation encoder pulses	45	C5	3
Control system function	374	Overspeed detection level	4A	CA	3
S-pattern C	380	Acceleration S pattern 1	50	D0	3
	381	Deceleration S pattern 1	51	D1	3
	382	Acceleration S pattern 2	52	D2	3
	383	Deceleration S pattern 2	53	D3	3
Pulse train input	384	Input pulse division scaling factor	54	D4	3
	385	Speed for zero input pulse	55	D5	3
	386	Speed for maximum input pulse	56	D6	3
Orientation	393	Orientation selection	5D	DD	3
	394	Number of machine side gear teeth	5E	DE	3
	395	Number of motor side gear teeth	5F	DF	3
	396	Orientation speed gain (P term)	60	E0	3
	397	Orientation speed integral time	61	E1	3
	398	Orientation speed gain (D term)	62	E2	3
	399	Orientation deceleration ratio	63	E3	3
Extension inputs	400	DI11 terminal function selection	00	80	4
	401	DI12 terminal function selection	01	81	4
	402	DI13 terminal function selection	02	82	4
	403	DI14 terminal function selection	03	83	4
	404	DI15 terminal function selection	04	84	4
	405	DI16 terminal function selection	05	85	4
	406	High resolution analog input selection	06	86	4
	407	Motor temperature detection filter	07	87	4
Additional function	408	Motor thermistor selection	08	88	4
Extension outputs	410	DO11 terminal function selection	0A	8A	4
	411	DO12 terminal function selection	0B	8B	4
	412	DO13 terminal function selection	0C	8C	4
	413	Encoder pulse output division ratio	0D	8D	4
Position control	419	Position command source selection	13	93	4
	420	Command pulse scaling factor numerator	14	94	4
	421	Command pulse scaling factor denominator	15	95	4
	422	Position loop gain	16	96	4
	423	Position feed forward gain	17	97	4
	424	Position command acceleration/deceleration time constant	18	98	4
	425	Position feed forward command filter	19	99	4
	426	In-position width	1A	9A	4
	427	Excessive level error	1B	9B	4
	428	Command pulse selection	1C	9C	4
	429	Clear signal selection	1D	9D	4
	430	Pulse monitor selection	1E	9E	4
Torque command	432	Pulse train torque command bias	20	A0	4
	433	Pulse train torque command gain	21	A1	4
Position control	434	IP address 1	22	A2	4
	435	IP address 2	23	A3	4
	436	IP address 3	24	A4	4
	437	IP address 4	25	A5	4
	438	Sub-net mask 1	26	A6	4
	439	Sub-net mask 2	27	A7	4
	440	Sub-net mask 3	28	A8	4
	441	Sub-net mask 4	29	A9	4
	442	Gateway address 1	2A	AA	4
	443	Gateway address 2	2B	AB	4
	444	Gateway address 3	2C	AC	4
	445	Gateway address 4	2D	AD	4
	446	Password	2E	AE	4
Torque command	447	Digital torque command bias	2F	AF	4
	448	Digital torque command gain	30	B0	4

Function	Parameter No.	Name	Instruction Code		Link Parameter Expansion Setting (Instruction code 7F/FF)
			Read	Write	
Motor constants	450	Second applied motor	32	B2	4
	451	Second motor control method selection	33	B3	4
	452	Second electronic thermal O/L relay	34	B4	4
	453	Second motor capacity	35	B5	4
	454	Number of second motor poles	36	B6	4
Position control	464	Digital position control sudden stop deceleration time	40	C0	4
	465	First position feed amount lower 4 digits	41	C1	4
	466	First position feed amount upper 4 digits	42	C2	4
	467	Second position feed amount lower 4 digits	43	C3	4
	468	Second position feed amount upper 4 digits	44	C4	4
	469	Third position feed amount lower 4 digits	45	C5	4
	470	Third position feed amount upper 4 digits	46	C6	4
	471	Fourth position feed amount lower 4 digits	47	C7	4
	472	Fourth position feed amount upper 4 digits	48	C8	4
	473	Fifth position feed amount lower 4 digits	49	C9	4
	474	Fifth position feed amount upper 4 digits	4A	CA	4
	475	Sixth position feed amount lower 4 digits	4B	CB	4
	476	Sixth position feed amount upper 4 digits	4C	CC	4
	477	Seventh position feed amount lower 4 digits	4D	CD	4
	478	Seventh position feed amount upper 4 digits	4E	CE	4
	479	Eighth position feed amount lower 4 digits	4F	CF	4
	480	Eighth position feed amount upper 4 digits	50	D0	4
	481	Ninth position feed amount lower 4 digits	51	D1	4
	482	Ninth position feed amount upper 4 digits	52	D2	4
	483	Tenth position feed amount lower 4 digits	53	D3	4
	484	Tenth position feed amount upper 4 digits	54	D4	4
	485	Eleventh position feed amount lower 4 digits	55	D5	4
	486	Eleventh position feed amount upper 4 digits	56	D6	4
	487	Twelfth position feed amount lower 4 digits	57	D7	4
	488	Twelfth position feed amount upper 4 digits	58	D8	4
489	Thirteenth position feed amount lower 4 digits	59	D9	4	
490	Thirteenth position feed amount upper 4 digits	5A	DA	4	
491	Fourteenth position feed amount lower 4 digits	5B	DB	4	
492	Fourteenth position feed amount upper 4 digits	5C	DC	4	
493	Fifteenth position feed amount lower 4 digits	5D	DD	4	
494	Fifteenth position feed amount upper 4 digits	5E	DE	4	
Remote output	495	Remote output selection	5F	DF	4
	496	Remote output data 1	60	E0	4
	497	Remote output data 2	61	E1	4
Communication	499	Action selection at SSCNET communication interruption	63	E3	4
	500	Communication error recognition waiting time	00	80	5
	501	Communication error occurrence count display	01	81	5
	502	Stop mode selection at communication error	02	82	5
Display function	505	Speed setting reference	05	85	5
Operation selection functions	800	Control system selection (simple mode)	00	80	8
	801	Torque characteristic selection	01	81	8
	802	Pre-excitation selection	02	82	8
	803	Constant power range torque characteristic selection	03	83	8
	804	Torque command source selection	04	84	8
	805	Torque command source (RAM)	05	85	8
	806	Torque command source (RAM, E <sup>2</sup> PROM)	06	86	8
	807	Speed limit selection	07	87	8
	808	Forward rotation speed limit	08	88	8
809	Reverse rotation speed limit	09	89	8	

## Parameter Instruction Code List

Function	Parameter No.	Name	Instruction Code		Link Parameter Expansion Setting (Instruction code 7F/FF)	
			Read	Write		
Control system functions	810	Torque limit input method selection	0A	8A	8	
	811	Set resolution switchover	0B	8B	8	
	812	Torque limit level (regeneration)	0C	8C	8	
	813	Torque limit level (3rd quadrant)	0D	8D	8	
	814	Torque limit level (4th quadrant)	0E	8E	8	
	815	Torque limit level 2	0F	8F	8	
	816	Acceleration torque limit level	10	90	8	
	817	Deceleration torque limit level	11	91	8	
	818	Easy gain tuning response level setting (simple mode)	12	92	8	
	819	Easy gain tuning selection (simple mode)	13	93	8	
	820	Speed control P gain 1	14	94	8	
	821	Speed control integral time 1	15	95	8	
	822	Speed setting filter 1	16	96	8	
	823	Speed detection filter 1	17	97	8	
	824	Torque control P gain 1	18	98	8	
	825	Torque control integral time 1	19	99	8	
	826	Torque setting filter 1	1A	9A	8	
	827	Torque detection filter 1	1B	9B	8	
	828	Model speed control gain	1C	9C	8	
	830	Speed control P gain 2	1E	9E	8	
	831	Speed control integral time 2	1F	9F	8	
	832	Speed setting filter 2	20	A0	8	
	833	Speed detection filter 2	21	A1	8	
	834	Torque control P gain 2	22	A2	8	
	835	Torque control integral time 2	23	A3	8	
	836	Torque setting filter 2	24	A4	8	
	837	Torque detection filter 2	25	A5	8	
	Torque biases	840	Torque bias selection	28	A8	8
		841	Torque bias 1	29	A9	8
		842	Torque bias 2	2A	AA	8
		843	Torque bias 3	2B	AB	8
		844	Torque bias filter	2C	AC	8
		845	Torque bias operation time	2D	AD	8
		846	Torque bias balance compensation	2E	AE	8
		847	Fall-time torque bias terminal 3 bias	2F	AF	8
		848	Fall-time torque bias terminal 3 gain	30	B0	8
		849	Analog input offset adjustment	31	B1	8
Additional functions	851	Number of encoder pulses	33	B3	8	
	852	Encoder rotation direction	34	B4	8	
	854	Excitation ratio	36	B6	8	
	859	Torque current	3B	BB	8	
	862	Notch filter frequency	3E	BE	8	
	863	Notch filter depth	3F	BF	8	
	864	Torque detection	40	C0	8	
Display functions	865	Low speed detection	41	C1	8	
	866	Torque monitoring reference	42	C2	8	
Terminal assignment function	867	DA1 output filter	43	C3	8	
	868	Terminal 1 function assignment	44	C4	8	
Protective functions	870	Speed deviation level	46	C6	8	
	871	Speed deviation time	47	C7	8	
	873	Speed limit	49	C9	8	
	874	OLT level setting	4A	CA	8	
Operation selection functions	875	Fault definition	4B	CB	8	
	876	Thermal relay protector input	4C	CC	8	
Control system functions	877	Speed feed forward/model adaptive speed control selection	4D	CD	8	
	878	Speed feed forward filter	4E	CE	8	
	879	Speed feed forward torque limit	4F	CF	8	
	880	Load inertia ratio	50	D0	8	
	881	Speed feed forward gain	51	D1	8	
Maintenance functions	890	Maintenance output setting time	5A	DA	8	
	891	Maintenance output timer	5B	DB	8	
	892	Maintenance output signal clear	5C	DC	8	

Function	Parameter No.	Name	Instruction Code		Link Parameter Expansion Setting (Instruction code 7F/FF)
			Read	Write	
Calibration functions	900	DA1 terminal calibration	5C	DC	1
	901	DA2 terminal calibration	5D	DD	1
	902	Speed setting terminal 2 bias	5E	DE	1
	903	Speed setting terminal 2 gain	5F	DF	1
	904	Torque command terminal 3 bias	60	E0	1
	905	Torque command terminal 3 gain	61	E1	1
	917	Terminal 1 bias (speed)	11	91	9
	918	Terminal 1 gain (speed)	12	92	9
	919	Terminal 1 bias (torque/magnetic flux)	13	93	9
	920	Terminal 1 gain (torque/magnetic flux)	14	94	9
	925	Motor temperature detection calibration	19	99	9
	926	Terminal 6 bias (speed)	1A	9A	9
	927	Terminal 6 gain (speed)	1B	9B	9
	928	Terminal 6 bias (torque)	1C	9C	9
929	Terminal 6 gain (torque)	1D	9D	9	
Additional functions	990	PU buzzer control	5A	DA	9
	991	PU contrast adjustment	5B	DB	9

**CAUTION**

**Note that read and write of the Pr. 77 and Pr. 79 values are enabled for computer link operation that uses the PU connector, but write is disabled for computer link operation that uses the option (FR-A5NR).**

## SERIAL number check

### Appendix3 SERIAL number check

Check the SERIAL number indicated on the rating plate and package for the inverter SERIAL number.

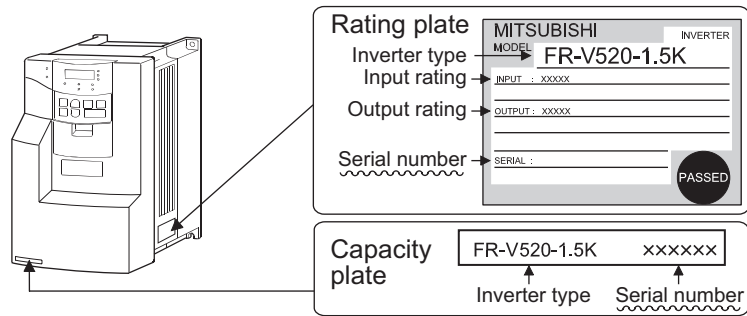

SERIAL is made up of 1 version symbol and 8 numeric characters indicating the year, month, and control number as shown below.

<u>R</u>	<u>1</u>	<u>8</u>	<u>000000</u>
Symbol	Year	Month	Control number
Serial number			

# MEMO

REVISIONS

\*The manual number is given on the bottom left of the back cover.

Print Date	*Manual Number	Revision
Oct., 2002	IB(NA)-0600131E-A	First edition
Nov., 2003	IB(NA)-0600131E-B	<div data-bbox="564 315 794 342" style="border: 1px solid black; padding: 2px;">Partial modifications</div> <ul style="list-style-type: none"> <li>•Setting range of the electronic gear (Pr.420, Pr.421)</li> <li>•Process value input range during PID control (terminal 1)</li> </ul> <div data-bbox="564 416 667 443" style="border: 1px solid black; padding: 2px;">Addition</div> <ul style="list-style-type: none"> <li>•SF-V5RU</li> </ul>
Nov.,2006	IB(NA)-0600131E-C	<div data-bbox="564 495 667 521" style="border: 1px solid black; padding: 2px;">Addition</div> <ul style="list-style-type: none"> <li>•Pr. 408 "motor thermistor selection"</li> <li>•Pr. 505 "speed setting reference"</li> <li>•Addition of "9" to the setting range of Pr. 800 "control system selection".</li> <li>•Addition of "5, 6" to the setting range of Pr. 804 "torque command source selection".</li> <li>•Pr. 811 "set resolution switchover"</li> </ul> <div data-bbox="564 696 794 723" style="border: 1px solid black; padding: 2px;">Partial modifications</div> <ul style="list-style-type: none"> <li>•Settings of Pr.3 "base frequency" and Pr. 84 "rated motor frequency" were changed to "10Hz to 200Hz"</li> </ul>

# FR-V500, A700, A701 Series

## Instruction Manual Supplement

When installing a thermal relay to the cooling fan of the vector-control dedicated motors (SF-V5RU), use the following recommended thermal relay settings.

- 200V class (Mitsubishi dedicated motor [SF-V5RU (1500r/min series)])

Motor type SF-V5RU□□K		1	2	3	5	7	11	15	18	22	30	37	45	55	
Cooling fan (with thermal protector)*2*3	Voltage	Single-phase 200V/50Hz Single-phase 200V to 230V/60Hz					Three-phase 200V/50Hz Three-phase 200 to 230V/60Hz								
	Input *1	36/55W (0.26/0.32A)		22/28W (0.11/0.13A)		55/71W (0.37/0.39A)			100/156W (0.47/0.53A)			85/130W (0.46/0.52A)			
	Thermal relay settings	0.36A		0.18A		0.51A			0.69A			0.68A			

- 400V class (Mitsubishi dedicated motor [SF-V5RUH (1500r/min series)])

Motor type SF-V5RUH□□K		1	2	3	5	7	11	15	18	22	30	37	45	55	
Cooling fan (with thermal protector)*2*3	Voltage	Single-phase 200V/50Hz Single-phase 200V to 230V/60Hz					Three-phase 380 to 400V/50Hz Three-phase 400 to 460V/60Hz								
	Input *1	36/55W (0.26/0.32A)		22/28W (0.11/0.13A)		55/71W (0.19/0.19A)			100/156W (0.27/0.30A)			85/130W (0.23/0.26A)			
	Thermal relay settings	0.36A		0.18A		0.25A			0.39A			0.34A			

\*1 Power (current) at 50Hz/60Hz.

- \*2 The cooling fan is equipped with a thermal protector. The cooling fan stops when the coil temperature exceeds the specified value in order to protect the fan motor. A restrained cooling fan or degraded fan motor insulation may cause the rise in coil temperature. The fan motor re-starts when the coil temperature drops to normal.
- \*3 The voltage and input values are the standard specifications of the cooling fan in free air. When the cooling fan is used with a motor, it requires more energy to perform its work, and thus the above input values become slightly larger. The cooling fan can, however, be used as it is without causing problems. When a thermal relay is to be prepared at the customer's side, use the recommended thermal relay settings.