

# MITSUBISHI

A950GOT/A951GOT/A953GOT/A956GOT

User's Manual

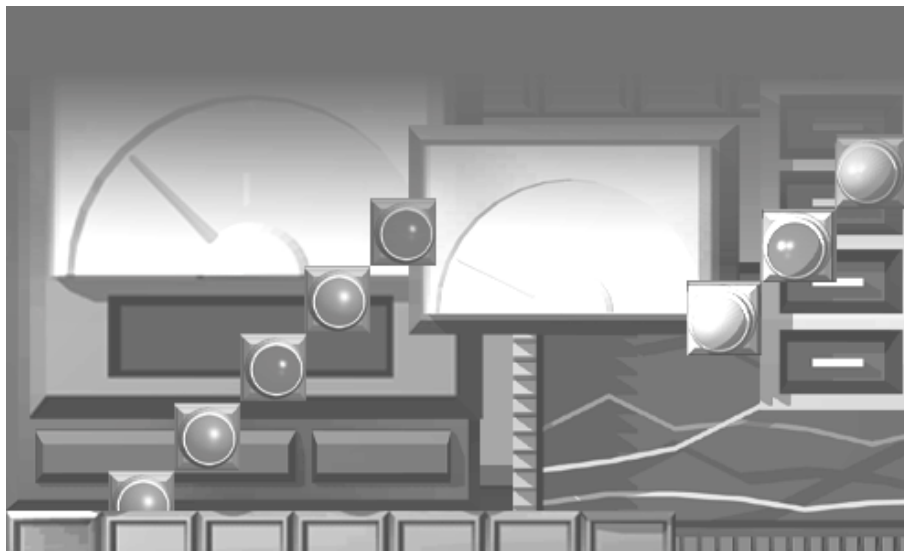

*Graphic Operation Terminal*  
**900**  
series



MITSUBISHI Graphic Operation Terminal

A950GOT-TBD(-M3)/SBD(-M3)/SBD(-M3)-B/LBD(-M3)  
A951GOT-QTBD(-M3)/QSBD(-M3)/QSBD(-M3)-B/QLBD(-M3)  
A951GOT-TBD(-M3)/SBD(-M3)/SBD(-M3)-B/LBD(-M3)  
A953GOT-TBD(-M3)/SBD(-M3)/SBD(-M3)-B/LBD(-M3)  
A956GOT-TBD(-M3)/SBD(-M3)/SBD(-M3)-B/LBD(-M3)  
A956WGOT-TBD



# ● SAFETY PRECAUTIONS ●

(Always read these instructions before using this equipment.)

Before using this product, please read this manual and the relevant manuals introduced in this manual carefully and pay full attention to safety to handle the product correctly.

The instructions given in this manual are concerned with this product. For the safety instructions of the programmable controller system, please read the CPU module user's manual.

In this manual, the safety instructions are ranked as "DANGER" and "CAUTION".



**DANGER**

Indicates that incorrect handling may cause hazardous conditions, resulting in death or severe injury.



**CAUTION**

Indicates that incorrect handling may cause hazardous conditions, resulting in medium or slight personal injury or physical damage.

Note that the  CAUTION level may lead to a serious consequence according to the circumstances. Always follow the instructions of both levels because they are important to personal safety.

Please save this manual to make it accessible when required and always forward it to the end user.

## [Design Precautions]

### **DANGER**

- Depending on the GOT main unit, communication board, communication module or cable fault, the output from the GOT interface module may remain ON or may remain OFF.  
An external monitoring circuit should be provided to check for output signals which may lead to a serious accident.  
Not doing so can cause an accident due to false output or malfunction.
- If a communication fault (including cable disconnection) occurs during monitoring on the GOT, communication between the GOT and PLC CPU is suspended and the GOT becomes inoperative.  
For bus connection : The CPU becomes faulty and the GOT inoperative.  
For other than bus connection : The GOT becomes inoperative.  
A system where the GOT is used should be configured to perform any significant operation to the system by using the switches of a device other than the GOT on the assumption that a GOT communication fault will occur.  
Not doing so can cause an accident due to false output or malfunction.
- Do not use the GOT as the warning device that may cause a serious accident.  
An independent and redundant hardware or mechanical interlock is required to configure the device that displays and outputs serious warning.  
Failure to observe this instruction may result in an accident due to incorrect output or malfunction.

## [Design Precautions]

### **DANGER**

- Incorrect operation of the touch switch(s) may lead to a serious accident if the GOT backlight is gone out.

When the GOT backlight goes out, the display section turns black and causes the monitor screen to appear blank, while the input of the touch switch(s) still remains active.

This may confuse an operator in thinking that the GOT is in “screensaver” mode, who then tries to release the GOT from this mode by touching the display section, which may cause a touch switch to operate.

Note that the following occurs on the GOT when the backlight goes out.

- The monitor screen disappears even when the screensaver is not set.
- The monitor screen will not come back on by touching the display section, even if the screensaver is set.

### **CAUTION**

- Do not bundle the control and communication cables with main-circuit, power or other wiring. Run the above cables separately from such wiring and keep them a minimum of 100mm apart. Not doing so noise can cause a malfunction.

## [Mounting Precautions]

### **DANGER**

- Before installing or removing the GOT main unit to or from an enclosure, always turn the GOT power OFF before installing or removing the GOT main unit to or from an enclosure. Not doing so can cause a module failure or malfunction.
- Before loading or unloading the communication board, communication module, external I/O interface module or memory card interface module to or from the GOT, always turn the GOT power OFF before loading or unloading the communication board, communication module, external I/O interface module or memory card interface module to or from the GOT. Not doing so can cause a module failure or malfunction.

### **CAUTION**

- The GOT should be used in the environment given in the general specifications of this user's manual. Not doing so can cause an electric shock, fire, malfunction or product damage or deterioration.
- When mounting the GOT main unit to an enclosure, tighten the mounting screws in the specified torque range. Undertightening can cause a drop, short circuit or malfunction. Overtightening can cause a drop, short circuit or malfunction due to the damage of the screws or module.

## [Mounting Precautions]

### CAUTION

- When loading the communication board, External I/O interface module or communication module to the GOT main unit, fit it to the connection interface of the GOT and tighten the mounting screws in the specified torque range.  
Undertightening can cause a drop, failure or malfunction.  
Overtightening can cause a drop, failure or malfunction due to the damage of the screws or module.
- When loading the communication board to the GOT main unit, take care not to become injured by the components that are installed or surrounding materials.
- When loading the communication board to the GOT main unit, remove any static electricity accumulated on your body before engaging in work.  
Otherwise, this may result in damage to the board.

## [Wiring Precautions]

### DANGER

- Before starting wiring, always turn the GOT power OFF before starting wiring.  
Not doing so may cause an electric shock, product damage or malfunction.

### CAUTION

- Please make sure to ground FG terminal of the GOT power supply unit by applying Class D Grounding (Class 3 Grounding Method) or higher which is used exclusively for the GOT.  
Not doing so may cause an electric shock or malfunction.
- Correctly wire the power supply module on the GOT after confirming the rated voltage and terminal arrangement of the product.  
Not doing so can cause a fire or failure.
- Tighten the terminal screws of the GOT power supply section in the specified torque range.  
Undertightening can cause a short circuit or malfunction.  
Overtightening can cause a short circuit or malfunction due to the damage of the screws or module.
- Exercise care to avoid foreign matter such as chips and wire offcuts entering the module.  
Not doing so can cause a fire, failure or malfunction.
- Plug the bus connection cable by inserting it into the connector of the connected module until it "clicks".  
After plugging, check that it has been inserted snugly.  
Not doing so can cause a malfunction due to a contact fault.
- Plug the communication cable into the connector of the connected module and tighten the mounting and terminal screws in the specified torque range.  
Undertightening can cause a short circuit or malfunction.  
Overtightening can cause a short circuit or malfunction due to the damage of the screws or module.

## [Test Operation Precautions]

### **DANGER**

- Before performing test operation (bit device on/off, word device's present value changing, timer/counter's set value and present value changing, buffer memory's present value changing) for a user-created monitor screen or system monitoring, read the manual carefully to fully understand how to operate the equipment.  
During test operation, never change the data of the devices which are used to perform significant operation for the system.  
False output or malfunction can cause an accident.

## [Startup/Maintenance Precautions]

### **DANGER**

- When opening the panel on which the GOT is installed, always power off the GOT.  
Not doing so can cause the GOT to fail or malfunction.
- When power is on, do not touch the terminals.  
Doing so can cause an electric shock or malfunction.
- Do not change the extension number setting switch and I/O slot setting switch setting during power-on.  
Doing so can cause a malfunction.
- Before starting cleaning or terminal screw retightening, always turn the power OFF before starting cleaning or terminal screw retightening.  
Not switching the power off in all phases can cause a module failure or malfunction.  
Undertightening can cause a short circuit or malfunction.  
Overtightening can cause a short circuit or malfunction due to the damage of the screws or module.
- When touching the GOT, communication unit, and/or option unit, or before touching the panel with the GOT installed, touch a grounded metal object to discharge the static electricity from the human body.  
Failure to do so may cause the unit to fail or malfunction.

### **CAUTION**

- Do not disassemble or modify the module.  
Doing so can cause a failure, malfunction, injury or fire.
- Do not touch the conductive and electronic parts of the module directly.  
Doing so can cause a module malfunction or failure.
- The cables connected to the module must be run in ducts or clamped.  
Not doing so can cause the module or cable to be damaged due to the dangling, motion or accidental pulling of the cables or can cause a malfunction due to a cable connection fault.
- When unplugging the cable connected to the module, do not hold and pull the cable portion.  
Doing so can cause the module or cable to be damaged or can cause a malfunction due to a cable connection fault.

## [Backlight Changing Precautions]

### **DANGER**

- Before changing the backlight, always turn the GOT power OFF (when using a GOT bus connection, also turn OFF the PLC CPU power), and remove the GOT main unit from the panel before changing the backlight.  
Not switching the power off in all phases may cause an electric shock.  
Not removing the unit from the enclosure can cause injury due to a drop.

### **CAUTION**

- When replacing the backlight, use the gloves.  
Otherwise, it may cause you to be injured.  
If you should directly touch the plated area of the main unit case with hand, be sure to wipe off the fingerprint and so on, and install the main unit case.  
Otherwise, it may cause a trouble or malfunction.
- Start changing the backlight more than 5 minutes after switching the GOT power off.  
Not doing so can cause a burn due to the heat of the backlight.

## [Disposal Precautions]

### **CAUTION**

- When disposing of the product, handle it as industrial waste.

## REVISIONS

\* The manual number is given on the bottom left of the back cover..

Print Date	* Manual Number	Revision
Jul., 1999	SH (NA)-080018-A	First edition
Mar., 2000	SH (NA)-080018-B	<p><b>Partial correction</b></p> <p>Section 1.1, Chapter 5, Section 6.2, Section 6.3, Section 6.5, Section 6.6, Section 6.7, Section 6.8</p> <p><b>Partial addition</b></p> <p>Section 2.1, Section 2.3, Section 3.1, Section 3.2, Section 3.3, Chapter 4, Section 6.1, Section 6.4, Section 7.4, Appendix 1, Appendix 2, Appendix 3, Index</p> <p><b>Addition</b></p> <p>Section 2.2, Section 2.4, Section 6.9, Section 8.4</p> <p><b>Addition model</b></p> <p>Descriptions of A951GOT-QTBD/QSBD/QLBD(-M3) are added.            Descriptions of A950/951/953/956GOT-TBD(-M3) are added.</p>
Feb., 2001	SH (NA)-080018-C	<p><b>Partial correction</b></p> <p>Section 1.1, Section 2.1, Section 2.2, Section 2.3, Section 2.4, Section 3.1, Section 3.3, Section 4.1, Section 6.1, Section 6.2, Section 6.4, Section 6.7, Section 6.8, Section 6.9, Section 6.10, Section 6.11, Section 6.12, Section 7.4, Section 8.2, Section 8.3, Appendix 1, Appendix 2</p> <p><b>Addition</b></p> <p>Section 6.3, Section 6.5, Section 6.6</p> <p>Additional model</p> <p>Descriptions of A956WGOT-TBD is added.</p>
May, 2001	SH (NA)-080018-D	<p><b>Partial correction</b></p> <p>Section 6.3.1</p> <p><b>Partial addition</b></p> <p>Section 1.1, Section 2.2, Section 2.3, Section 3.2, Section 6.7.1, Section 6.12.2, Section 9.2, Appendix 2</p> <p><b>Addition</b></p> <p>Chapter 8</p>
Feb., 2002	SH (NA)-080018-E	<p><b>Partial correction</b></p> <p>SAFETY PRECAUTIONS</p>
Apr., 2002	SH (NA)-080018-F	<p><b>Partial correction</b></p> <p>Section 8.2.2, Section 8.2.3, Section 8.2.5</p> <p><b>Partial addition</b></p> <p>Chapter 4, Section 8.2.1, Section 8.3.1, Section 8.3.2, Section 8.3.3, Section 9.2</p> <p><b>Addition</b></p> <p>Section 8.2.4</p>



Print Date	* Manual Number	Revision
Sep., 2004	SH (NA)-080018-G	<p><b>MODEL CODE change</b> Changed from 13JL92 to 1DM103.</p> <p><b>Partial correction</b> Chapter 1, Section 2.1, Section 2.2.2, Section 2.3, Section 2.4, Section 2.5, Section 3.1, Section 3.2, Chapter 4, Chapter 5, Section 6.1.3, Section 6.3.1, Section 6.4.2, Section 6.4.3, Section 6.4.4, Section 6.5, Section 6.8.2, Section 6.9.2, Section 6.10.1, Section 6.10.2, Section 6.12.2, Section 7.4, Section 8.1.1, Section 8.2.2, Section 8.2.4, Section 8.3.2, Section 8.3.3, Section 9.3, Appendix 1, WARRANTY</p> <p><b>Partial addition</b> Section 3.2, Section 6.7.1, Section 6.7.2, Appendix 2</p> <p><b>Addition</b> Section 6.2, Section 6.2.1, Section 6.2.2, Section 6.2.3, Section 6.2.4, Section 6.13</p> <p><b>Addition model</b> A95*GOT-SBD(-M3)-B, A95*GOT-QSBD(-M3)-B</p>
Dec., 2005	SH (NA)-080018-H	<p><b>Partial correction</b> Section 3.2, Section 9.3, Appendix 3</p> <p><b>Partial addition</b> Section 9.2</p>
Oct., 2006	SH (NA)-080018-I	<p><b>Partial correction</b> SAFETY PRECAUTIONS, Section 2.3, Section 3.2, Section 3.3, Section 8.1.1, Section 8.3.2</p> <p><b>Partial addition</b> Section 8.2.5, Section 8.3.1, Section 8.3.2, Section 8.3.3</p>
Nov., 2006	SH (NA)-080018-J	<p><b>Partial correction</b> Layouts were revised.</p>

Japanese Manual Version SH-080011-H

This manual confers no industrial property rights or any rights of any other kind, nor does it confer any patent licenses. Mitsubishi Electric Corporation cannot be held responsible for any problems involving industrial property rights which may occur as a result of using the contents noted in this manual.

# INTRODUCTION

Thank you for choosing the Mitsubishi Graphic Operation Terminal.

Before using the equipment, please read this manual carefully to use the equipment to its optimum.

A copy of this manual should be forwarded to the end user.

## CONTENTS

SAFETY PRECAUTIONS .....	A - 1
1. ABOUT THE MANUALS .....	A - 11
2. ABBREVIATIONS AND GENERIC TERMS IN THIS MANUAL .....	A - 12
3. PACKING LIST .....	A - 14
<b>1 OVERVIEW</b> .....	<b>1 - 1 to 1 - 4</b>
1.1 Features .....	1 - 3
<b>2 SYSTEM CONFIGURATION</b> .....	<b>2 - 1 to 2 - 12</b>
2.1 Overall Configuration .....	2 - 1
2.2 System Configuration of the GOT .....	2 - 3
2.3 Component List .....	2 - 3
2.4 Software Packages to be Used .....	2 - 9
2.5 Unusable Conventional Products .....	2 - 10
2.6 Notes on Q4ARCPU Duplex System .....	2 - 11
<b>3 PERFORMANCE</b> .....	<b>3 - 1 to 3 - 8</b>
3.1 General Specifications .....	3 - 1
3.2 Performance Specifications .....	3 - 2
3.3 Power Supply Specifications .....	3 - 8
<b>4 NAMES OF THE PARTS AND THEIR SETTINGS</b> .....	<b>4 - 1 to 4 - 2</b>
<b>5 ROUGH PRE-OPERATION PROCEDURE</b> .....	<b>5 - 1 to 5 - 2</b>
<b>6 HANDLING</b> .....	<b>6 - 1 to 6 - 29</b>
6.1 GOT Main Unit .....	6 - 1
6.1.1 Handling instructions .....	6 - 1
6.1.2 Installation method.....	6 - 3
6.1.3 Wiring method.....	6 - 5
6.1.4 Installation of handy type GOT .....	6 - 11
6.2 Protective Sheet .....	6 - 13
6.2.1 Protective sheet type .....	6 - 13
6.2.2 Mounting procedure.....	6 - 13
6.3 Memory board (A956WGOT only) .....	6 - 14
6.3.1 Memory board types .....	6 - 14
6.3.2 Mounting procedure.....	6 - 14

6.4	Memory Card Interface Module	6 - 15
6.4.1	Memory card interface module type .....	6 - 15
6.4.2	Mounting procedure.....	6 - 15
6.4.3	PC card types .....	6 - 16
6.4.4	Battery changing timing and method .....	6 - 16
6.4.5	Loading and unloading procedures .....	6 - 17
6.5	Compact flash PC card (A956WGOT only)	6 - 18
6.5.1	Compact flash PC card types .....	6 - 18
6.5.2	Loading and unloading procedures .....	6 - 19
6.6	Communication Board (A956WGOT only)	6 - 20
6.6.1	Communication board types .....	6 - 20
6.6.2	Mounting procedure.....	6 - 20
6.7	Communication Module (A956GOT, A956WGOT Only)	6 - 21
6.7.1	Connection module types .....	6 - 21
6.7.2	Mounting procedure.....	6 - 22
6.8	Printer Interface Module	6 - 24
6.8.1	Printer interface module type.....	6 - 24
6.8.2	How to connect the printer interface module .....	6 - 24
6.8.3	Printer types .....	6 - 25
6.8.4	Connecting procedure .....	6 - 25
6.9	External I/O Module	6 - 26
6.9.1	External I/O module type .....	6 - 26
6.9.2	Mounting procedure.....	6 - 26
6.10	Bar Code Reader	6 - 27
6.10.1	Bar code reader types .....	6 - 27
6.10.2	Connecting procedure .....	6 - 27
6.11	Debug Stand	6 - 28
6.11.1	Debug stand type .....	6 - 28
6.11.2	Mounting procedure.....	6 - 28
6.12	Attachment (A95*GOT only)	6 - 29
6.12.1	Attachment type.....	6 - 29
6.12.2	Mounting procedure.....	6 - 29

## 7 MAINTENANCE AND INSPECTION 7 - 1 to 7 - 4

7.1	Instructions for Maintenance and Inspection	7 - 1
7.2	Daily Inspection	7 - 2
7.3	Periodic Inspection	7 - 2
7.4	How to Change the Backlight for Liquid Crystal	7 - 3

## 8 EMC DIRECTIVE 8 - 1 to 8 - 19

8.1	Requirements for conformance to EMC Directive	8 - 1
8.1.1	Standards applicable to the EMC directive.....	8 - 2
8.1.2	Control cabinet .....	8 - 3
8.1.3	Grounding.....	8 - 4
8.2	System Configuration when EMC Directive is Applicable	8 - 5
8.2.1	Overall configuration.....	8 - 5
8.2.2	About modules applicable to the EMC directive .....	8 - 6

8.2.3	Connection format .....	8 - 7
8.2.4	When the communication/board module is used .....	8 - 7
8.2.5	About the cable used .....	8 - 8
8.3	Wiring Precautions the Part which Matches the EMC Directives .....	8 - 9
8.3.1	Method to connect the power wire and ground wire .....	8 - 9
8.3.2	Grounding the ground cable .....	8 - 11
8.3.3	Grounding the cable .....	8 - 19

<b>9 ERROR CODES AND ERROR MESSAGES</b>	<b>9 - 1 to 9 - 16</b>
---	------------------------

9.1	Definition of the Error Codes and Messages Displayed .....	9 - 1
9.2	Error Code and Error Message List .....	9 - 2
9.3	Precautions for Installation of ROM_BIOS .....	9 - 6
9.4	Troubleshooting in bus connection .....	9 - 9
9.4.1	Locating error positions .....	9 - 9
9.4.2	Further locating error positions .....	9 - 14
9.4.3	Specific example of troubleshooting .....	9 - 15
9.5	Troubleshooting for monitoring .....	9 - 16

<b>APPENDICES</b>	<b>App - 1 to App - 7</b>
-------------------	---------------------------

Appendix.1	Outline Dimension Drawings .....	App - 1
Appendix.2	Depth at the Time of Communication Module Loading (A956GOT/A956WGOT Only) .....	App - 3
Appendix.3	Outline Dimension Drawings of Bus Connection Cables .....	App - 7

<b>INDEX</b>	<b>Index - 1 to Index - 2</b>
--------------	-------------------------------

## **1. ABOUT THE MANUALS**

For details of the manuals relevant to this product, refer to the PDF manual stored within the drawing software used.

## 2. ABBREVIATIONS AND GENERIC TERMS IN THIS MANUAL



Abbreviations and generic terms used in this manual are described as follows:

Abbreviations and generic terms		Description
GOT	A950GOT	Generic term of A950GOT-TBD, A950GOT-SBD, A950GOT-SBD-B, A950GOT-LBD, A950GOT-TBD-M3, A950GOT-SBD-M3, A950GOT-SBD-M3-B and A950GOT-LBD-M3
	A951GOT	Generic term of A951GOT-TBD, A951GOT-SBD, A951GOT-SBD-B, A951GOT-LBD, A951GOT-TBD-M3, A951GOT-SBD-M3, A951GOT-SBD-M3-B and A951GOT-LBD-M3
	A951GOT-Q	Generic term of A951GOT-QTBD, A951GOT-QSBD, A951GOT-QSBD-B, A951GOT-QLBD, A951GOT-QTBD-M3, A951GOT-QSBD-M3, A951GOT-QSBD-M3-B and A951GOT-QLBD-M3
	A953GOT	Generic term of A953GOT-TBD, A953GOT-SBD, A953GOT-SBD-B, A953GOT-LBD, A953GOT-TBD-M3, A953GOT-SBD-M3, A953GOT-SBD-M3-B and A953GOT-LBD-M3
	A956GOT	Generic term of A956GOT-TBD, A956GOT-SBD, A956GOT-SBD-B, A956GOT-LBD, A956GOT-TBD-M3, A956GOT-SBD-M3, A956GOT-SBD-M3-B and A956GOT-LBD-M3
	A95* GOT	Generic term of A956GOT, A953GOT, A951GOT, A951GOT-Q and A950GOT
	A956WGOT	Abbreviation of A956WGOT-TBD
Communication board	Bus connection board	Generic term of A9GT-50WQBUISS and A9GT-50WBUSS
	Serial communication board	Generic term of A9GT-50WRS4 and A9GT-50WRS2
Communication unit	Bus connection unit	Generic term of A9GT-QBUS2SU, A9GT-BUSSU, A9GT-BUS2SU, A7GT-BUSS and A7GT-BUS2S
	Data link unit	Generic term of A7GT-J71AP23, A7GT-J71AR23 and A7GT-J71AT23B
	Network unit	Generic term of A9GT-QJ71LP23, A9GT-QJ71BR13, A7GT-J71LP23 and A7GT-J71BR13
	CC-Link communication unit	Generic term of A8GT-J61BT13 and A8GT-J61BT15
	Ethernet communication unit	Abbreviation of A9GT-J71E71-T
Option unit	External I/O unit	Abbreviation of A8GT-50KBF type external I/O interface unit
	Printer interface unit	Abbreviation of A9GT-50PRF type Printer interface unit
	Memory card interface unit	Abbreviation of A1SD59J-MIF type Memory card interface unit
Option	Backlight	Abbreviation of A9GT-50LT type backlight
	Debug stand	Abbreviation of A9GT-50STAND and A9GT-50WSTAND type debug stand
	Memory board	Abbreviation of A9GT-FNB, A9GT-FNB1M, A9GT-FNB2M, A9GT-FNB4M, A9GT-FNB8M, A9GT-QFNB, A9GT-QFNB4M, A9GT-QFNB8M type option function memory board
	Ten-key Panel	Abbreviation of A8GT-TK ten-key Panel
	A7GT-CNB	Abbreviation of A7GT-CNB bus connector conversion box
	A9GT-QCNB	Abbreviation of A9GT-QCNB bus connector conversion box
	Protection sheet	Abbreviation of A9GT-50PSC and A9GT-50WPSC type transparent protection sheets
	PC card (memory card)	Generic term of flash PC card, commercially available flash PC card and SRAM PC card
	Compact flash PC card	Abbreviation of commercially available compact flash PC card
	Attachment	Abbreviation of A85GT-95ATT attachment
Software	GT Works Version 5	Abbreviation of SW5D5C-GTWORKS-E(-V) software
	GT Designer Version 5	Abbreviation of SW5D5C-GOTR-PACKE(V) software
	GT Works2 Version1	Abbreviation of SW1D5C-GTWK2-E software
	GT Designer2 Version1	Abbreviation of SW1D5C-GTD2-E software
	GT Designer	Abbreviation of image creation software GT Designer for GOT900
	GT Designer2	Abbreviation of image creation software GT Designer2 for GOT900
	GT Simulator	Abbreviation of GT Simulator screen simulator GOT900
	GT Simulator2	Abbreviation of GT Simulator2 screen simulator GOT900
	GT Converter	Abbreviation of data conversion software GT Converter for GOT900
	GT Debugger	Abbreviation of debugging software GT Debugger
	GT Manager	Abbreviation of GT Manager data editing software for GOT900
	GT SoftGOT	Abbreviation of GT SoftGOT monitoring software
	GT SoftGOT2	Abbreviation of GT SoftGOT2 monitoring software
	GX Developer	Generic term of SW□D5C-GPPW-E/SW□D5F-GPPW-E software packages
	GX Simulator	Generic term of SW□D5C-LLT-E ladder logic test tool function software package (SW5D5C-LLT-E or later)
	Acrobat Reader	Abbreviation of Adobe Acrobat Reader

Abbreviations and generic terms		Description
CPU	QCPU (Q Mode)	Generic term of Q00JCPU, Q00CPU, Q01CPU, Q02CPU, Q02HCPU, Q06HCPU, Q12HCPU, Q25HCPU, Q12PHCPU and Q25PHCPU CPU
	QCPU (A Mode)	Generic term of Q02CPU-A, Q02HCPU-A and Q06HCPU-A CPU
	Remote I/O station	Network module for MELSECNET/H network system remote I/O station (QJ72LP25-25, QJ72LP25G, QJ72BR15)
	QCPU	Generic term of QCPU (Q Mode) and QCPU (A Mode)
	QnACPU Type	Generic term of Q2ACPU, Q2ACPU-S1, Q2AHCPU, Q2AHCPU-S1, Q3ACPU, Q4ACPU and Q4ARCPU CPU
	QnASCPU Type	Generic term of Q2ASCPU, Q2ASCPU-S1, Q2ASHCPU and Q2ASHCPU-S1 CPU
	QnACPU	Generic term of QnACPU Type and QnASCPU Type
	AnUCPU	Generic term of A2UCPU, A2UCPU-S1, A3UCPU and A4UCPU CPU
	AnACPU	Generic term of A2ACPU, A2ACPU-S1 and A3ACPU CPU
	AnNCPUCPU	Generic term of A1NCPUCPU, A2NCPUCPU, A2NCPUCPU-S1 and A3NCPUCPU CPU
	AnCPU Type	Generic term of AnUCPU, AnACPU and AnNCPUCPU CPU
	AnUS(H)CPU	Generic term of A2USCPU, A2USCPU-S1 and A2USHCPU-S1 CPU
	AnS(H)CPU	Generic term of A1SCPU, A1SCPUC24-R2, A2SCPU, A2SCPU-S1, A1SHCPU, A2SHCPU and A2SHCPU-S1 CPU
	A1SJ(H)CPU	Generic term of A1SJCPU, A1SJCPU-S3 and A1SJHCPU CPU
	AnSCPU Type	Generic term of A2US(H)CPU, AnS(H)CPU and A1SJ(H)CPU CPU
	ACPU	Generic term of AnCPU Type, AnSCPU Type, A1FXCPU, A0J2HCPU, A2CCPU, A2CCPU24 and A2CJCPU CPU
	FXCPU	Generic term of FX0 series, FX0N series, FX0S series, FX1 series, FX1N series, FX1S series, FX2 series, FX2C series, FX2N series, FXINS series, FX2NC and FX3UC series CPU
Motion controller CPU	Generic term of A273UCPU, A273UHCPU, A273UHCPU-S3, A373CPU, A373UCPU, A373UCPU-S3, A171SCPU, A171SCPU-S3, A171SCPU-S3N, A171SHCPU, A171SHCPUN, A172SHCPU, A172SHCPUN, A173UHCPU, A173UHCPU-S1, Q172CPU, Q173CPU, Q172CPUN, Q173CPUN CPU	
FA controller	Generic term of LM610, LM7600, LM8000 CPU	
Peripheral connection module	G4	Abbreviation of AJ65BT-G4-S3
Ethernet module	E71	Generic term of AJ71E71-S3, A1SJ71E71-B2-S3, A1SJ71E71-B5-S3, AJ71E71N-B2, AJ71E71N-B5T, A1SJ71E71N-B2 and A1SJ71E71N-B5T
	QE71	Generic term of AJ71QE71, A1S1-B2, AJ71QE71-B5, A1SJ71QE71-B5, AJ71QE71N-B2, AJ71QE71N-B5T, A1SJ71QE71N-B2 and A1SJ71QE71N-B5T
	Q series-compatible E71	Generic term of QJ71E71, QJ71E71-B2 and QJ71E71-100
Other PLC	Omron PLC	Generic term of C200HS, C200H, C200H $\alpha$ series(C200HX, C200HG, C200HE), CQM1, C1000H, C2000H, CV500, CV1000, CV2000, CVM1-CPU11, CVM1-CPU21, CS1, CS1D, CJ1M, CPM1, CPM1A, CPM2A, CPM2C CPU, CQM1H
	Yaskawa PLC	Generic term of GL60S, GL60H, GL70H, GL120, GL130, CP-9200SH, CP-9300MS, MP-920, MP-930, MP-940, CP-9200(H) and PROGIC-8 CPU
	SLC500 Series	Generic term of SLC500-20, SLC500-30, SLC500-40, SLC5/01 SLC5/02, SLC5/03, SLC5/04 SLC5/05
	MicroLogix1000 Series	Generic term of 1761-L10BWA, 1761-L10BWB, 1761-L16AWA, 1761-L16BWA, 1761-L16BWB, 1761-L16BBB, 1761-L32AWA, 1761-L32BWA, 1761-L32BWB, 1761-L32BBB, 1761-L32AAA, 1761-L20AWA-5A, 1761-L20BWA-5A, 1761-L20BWB-5A
	MicroLogix1500 Series	Abbreviation of 1764-LSP
	Allen-Bradley PLC	Generic term of SLC 500 Series, MicroLogix1000 Series, MicroLogix1500 Series
	Sharp PLC	Generic term of JW-21CU, JW-22CU, JW-31CUH, JW-32CUH, JW-33CUH, JW-50CUH, JW-70CUH, JW-100CUH, JW-100CU, Z-512J CPU
	PROSEC T Series	Generic term of T2(PU224 type), T2E, T2N, T3, T3H CPU
	PROSEC V Series	Generic term of S2T, Model3000(S3) CPU
	Toshiba PLC	Generic term of PROSEC T Series and PROSEC V Series
	SIEMENS PLC	Generic term of SIMATIC S7-300 Series and SIMATIC S7-400 Series CPU
	Large type H series	Generic term of H-302(CPU2-03H), H-702(CPU2-07H), H-1002(CPU2-10H), H-2002(CPU2-20H), H-4010(CPU3-40H), J-300(CPU-03Ha), H-700(CPU-07Ha), H-2000(CPU-20Ha)
	H200 to 252 Series	Generic term of H-200(CPU-02H, CPE-02H), H-250(CPU21-02H), H-252(CPU22-02H), H-252B(CPU22-02HB), H-252C(CPU22-02HC, CPE22-02HC)
	H Series board type	Generic term of H-20DR, H-28DR, H-40DR, H-64DR, H-20DT, H-28DT, H-40DT, H-64DT, HL-40DR, HL-64DR
	EH-150 Series	Generic term of EH-CPU104, EH-CPU208, EH-CPU308, EH-CPU316
HITACHI PLC (HIDIC H Series)	Generic term of large type H series, H-200 to 252 Series H Series board type, EH-150 Series	
Matsushita Electric Works PLC	Generic term of FP0-C16CT, FP0-C32CT, FP1-C24C, FP1-C40C, FP2, FP2SH, FP3, FP5, FP10(S), FP10SH, FP-M(C20TC) and FP-M(C32TC)	
Others	Memory	abbreviation of memory (flash memory) in the GOT
	OS	Abbreviation of GOT system software
	Object	Setting data for dynamic image
	Personal Computer	Personal computer where the corresponding software package is installed
	Servo amplifier	Generic term of the MR-J2S-□A, MR-J2S-□CP and MR-J2M A series
	MELDAS C6/C64	Generic term of the FCA C6, FCA C64

### 3. PACKING LIST

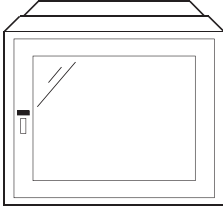
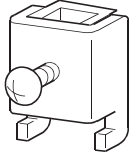
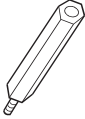
After unpacking, confirm that you have received the following products.

Product	Image	Quantity
GOT main unit		1
Mounting fixture		4
Communication module securing fixture (A956GOT, A956WGOT only)		3
Seal (A956WGOT only) * For use when closing the bus connection board setting switch confirmation hole.		1
A950GOT-TBD(-M3)/SBD(-M3)/SBD(-M3)-B/LBD(-M3), A951GOT-QTBD(-M3)/QSBD(-M3)/QSBD(-M3)-B/QLBD(-M3), A951GOT-TBD(-M3)/SBD(-M3)/SBD(-M3)-B/LBD(-M3), A953GOT-TBD(-M3)/SBD(-M3)/SBD(-M3)-B/LBD(-M3), A956GOT-TBD(-M3)/SBD(-M3)/SBD(-M3)-B/LBD(-M3) User's Manual (Hardware) * A956WGOT-TBD User's Manual (Hardware) *	1	

\* Changes with the GOT you purchased.



# 1 OVERVIEW

This user's manual explains the specifications, handling and other information of the A950GOT/A951GOT/A953GOT/A956GOT/A956WGOT graphic operation terminal module (abbreviated to the GOT).

The GOT can be used as an electronic operator panel which has achieved on its monitor screen the switch operation, lamp indication, data display, message display and other operations which were previously performed on an operator panel.

The following GOT types are available.

Type	Rough Specifications				
	Screen size [cm (inch)]	Interface built into main unit	Display section	Display color [color]	Power Supply type
A950GOT-TBD	15 (6)	Built-in RS-422 communication interface			24VDC
A950GOT-SBD					
A950GOT-SBD-B					
A950GOT-LBD					
A950GOT-TBD-M3					
A950GOT-SBD-M3					
A950GOT-SBD-M3-B					
A950GOT-LBD-M3					
A951GOT-QTBD					
A951GOT-QSBD					
A951GOT-QSBD-B					
A951GOT-QLBD					
A951GOT-QTBD-M3					
A951GOT-QSBD-M3					
A951GOT-QSBD-M3-B					
A951GOT-QLBD-M3					
A951GOT-TBD		Built-in bus communication interface (For A/QnA/Motion control- ler CPU)			
A951GOT-SBD					
A951GOT-SBD-B					
A951GOT-LBD					
A951GOT-TBD-M3					
A951GOT-SBD-M3					
A951GOT-SBD-M3-B					
A951GOT-LBD-M3					

1	OVERVIEW
2	SYSTEM CONFIGURATION
3	PERFORMANCE
4	NAMES OF THE PARTS AND THEIR SETTINGS
5	ROUGH PRE-OPERATION PROCEDURE
6	HANDLING
7	MAINTENANCE AND INSPECTION
8	EMC DIRECTIVE

The following GOT types are available.

Type	Rough Specifications				
	Screen size [cm (inch)]	Interface built into main unit	Display section	Display color [color]	Power Supply type
A953GOT-TBD	15 (6)	Built-in RS-232C communication interface	TBD(-M3): High-intensity TFT color liquid crystal	TBD(-M3): 256	24VDC
A953GOT-SBD					
A953GOT-SBD-B					
A953GOT-LBD					
A953GOT-TBD-M3					
A953GOT-SBD-M3					
A953GOT-SBD-M3-B					
A953GOT-LBD-M3		Built-in communication module interface	SBD(-M3)-B: High-intensity STN color liquid crystal SBD(-M3): STN color liquid crystal LBD(-M3): Monochrome liquid crystal	SBD(-M3), SBD(- M3)-B: 8 LBD(-M3): 2	
A956GOT-TBD					
A956GOT-SBD					
A956GOT-SBD-B					
A956GOT-LBD					
A956GOT-TBD-M3					
A956GOT-SBD-M3					
A956GOT-SBD-M3-B					
A956GOT-LBD-M3					
A956WGOT-TBD	18 (7)	Built-in communication board/module interface			

# 1.1 Features

(1) Medium-size display device occupying minimum installation area

The A95\*GOT/A956WGOT was made smaller in outline dimensions to greatly reduce the panel cut dimensions.

You can install the GOT according to your application.

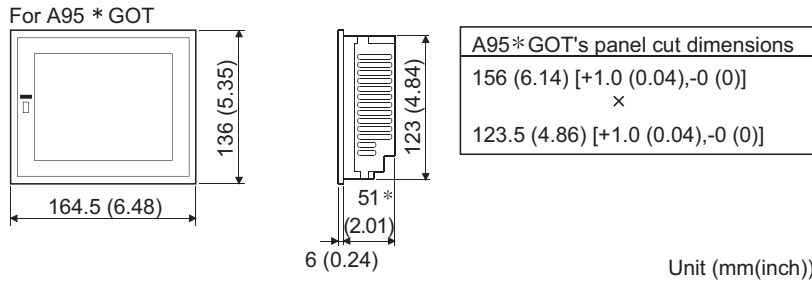

\*59 mm (2.32 in) for A95\*GOT-TBD, A95\*GOT-SBD(-M3)-B, A95\*GOT-QSBD(-M3)-B.

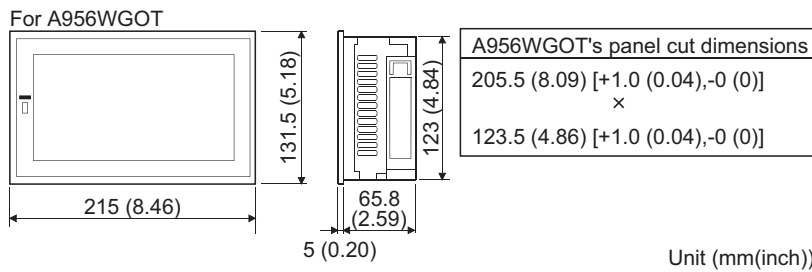

(2) Fast data transfer of OS and screen data by memory card

The PC card for OS and screen data can be created easily on a personal computer. By loading the created card into the memory card interface unit, you can exchange the OS and screen data rapidly. (RS-232C data transfer can also be made as conventionally.)

Also, a compact flash PC card can be used with the A956WGOT.

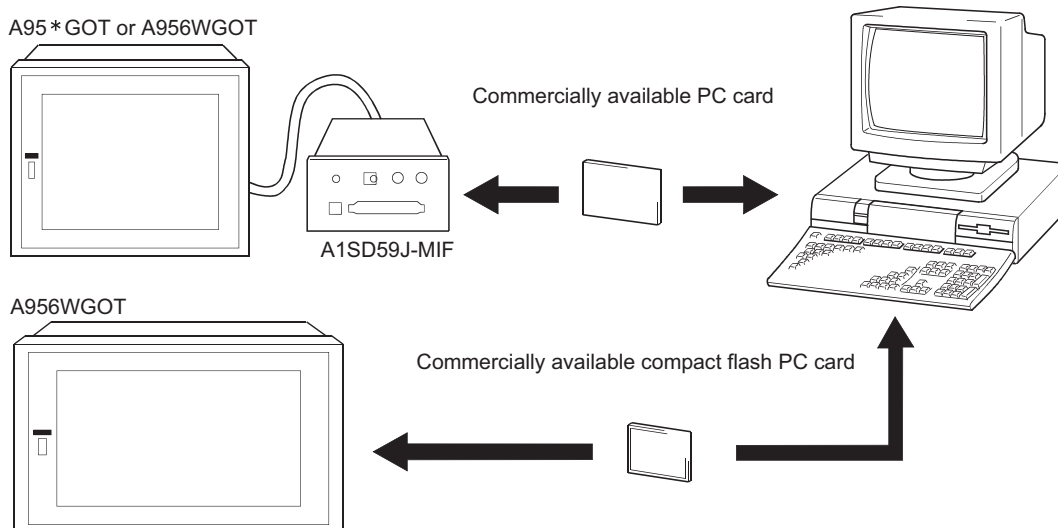

\* ROM\_BIOS cannot be installed with the compact flash PC card.

(3) Compatible with a wide variety of connection forms

The GOT models each contain their communication interfaces so that you can choose the connection form which meets your system.

The A951GOT-Q, A951GOT comes with a bus communication interface to make a bus connection for fast communication, the A953GOT has an RS-232C interface and A950GOT includes an RS-422 communication interface to make a CPU direct connection or computer link connection.

The A956GOT used with a communication module can make a bus connection, MELSECNET connection or CC-Link connection.

The A956WGOT used with a communication module or communication board can make a bus connection, Direct connection to CPU, computer link connection, MELSECNET connection, CC-Link connection or Ethernet connection.

(4) Heavy-duty body usable in rigorous environment and operation

The standard display section of the GOT complies with the IP67 and the NEMA4 Waterproof, Dustproof Standard and is usable in a wide range of environment.

(5) Maintenance function further enhanced in affinity with PLC

Upgraded alarm history function

The GOT can support the failure occurrence counting function, cumulative failure time totalizing function and history printing function, and start ladder monitoring with the corresponding device searched with a single keystroke at the failure detail display time.

(6) Improvement of safety by upgraded security function

- Supporting the operation protective function using up to 16 levels of passwords, the GOT can hide the display or disable input operation according to the password level. You can achieve hidden screens and hidden operations and easily change the display data per GOT used.
- You can specify the time delay function (ON delay/OFF delay) of the touch switches, double-pushing switches and interlock conditions to reduce malfunctions due to wrong key pushing.

(7) Wide, easy-to-see screen (A956WGOT only)

The A956WGOT can lay out more objects on the screen than it is possible with the A95\*GOT. By utilizing the monitor screen data of the A95\*GOT, the A956WGOT enables numeric value entry without hiding the monitor screen with a window for numeric value entry. This is achieved by arranging the ten keys for numeric value input next to the monitor screen data.

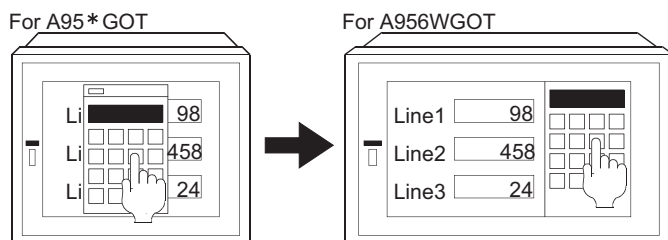

Numeric values can be entered without hiding the monitor screen with a window for numeric value entry.

# 2 SYSTEM CONFIGURATION

This chapter explains the system configuration of the GOT.

## 2.1 Overall Configuration

### (1) Overall configuration of the A95\*GOT

The overall configuration of the A95\*GOT is shown below.

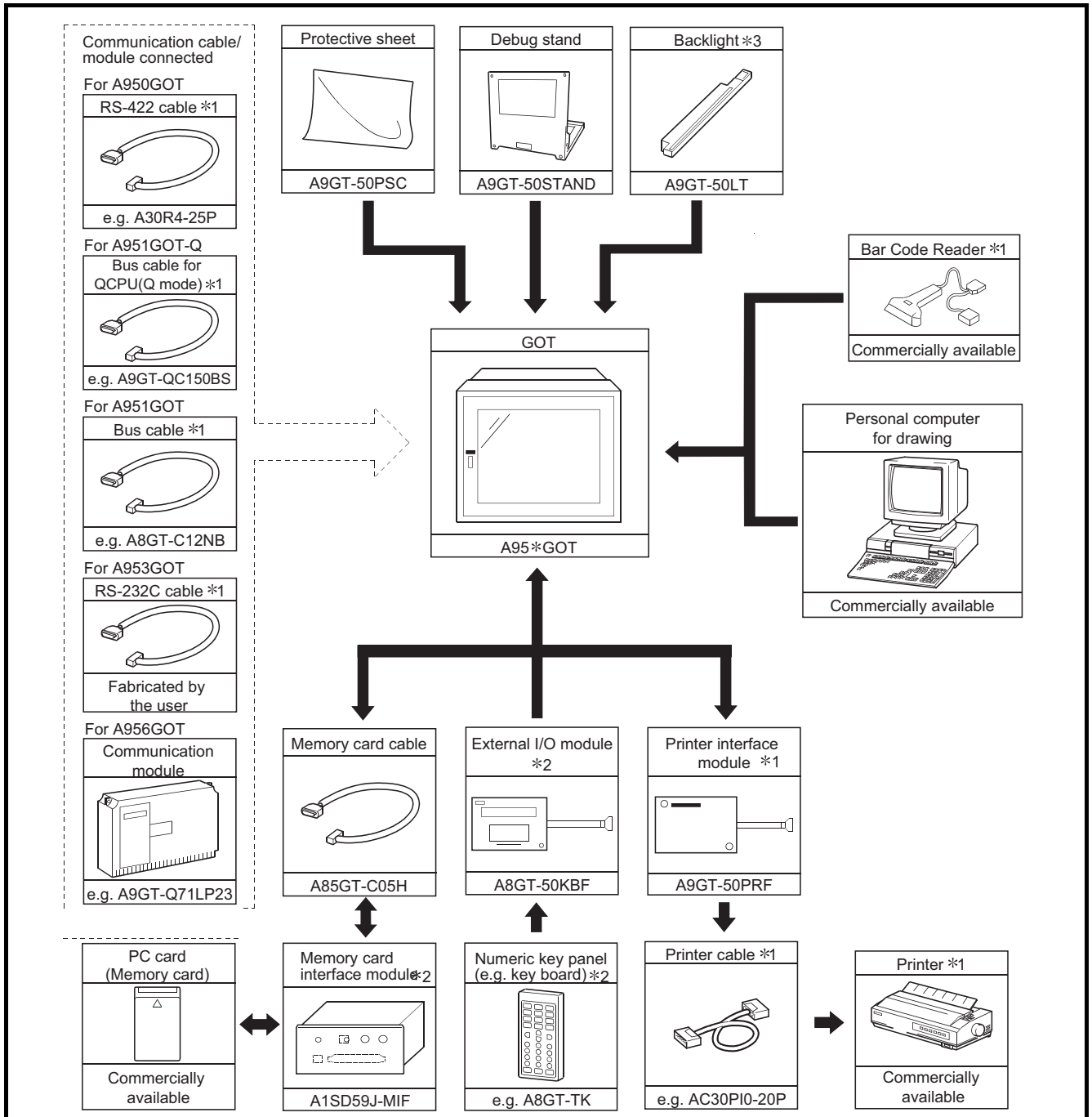

\*1 For details of the system configuration, refer to the [GOT-A900 Series User's Manual (Connection System Manual)].

\*2 For details on the system configuration, refer to the User's Manual of each module.

\*3 The A95\*GOT-SBD(-M3)-B, A95\*GOT-QSBD(-M3)-B and A95\*GOT-TBD(-M3) do not require their backlights to be replaced since they are installed with long-life backlights.

(2) Overall configuration of the A956WGOT

The overall configuration of the A956WGOT is shown below.

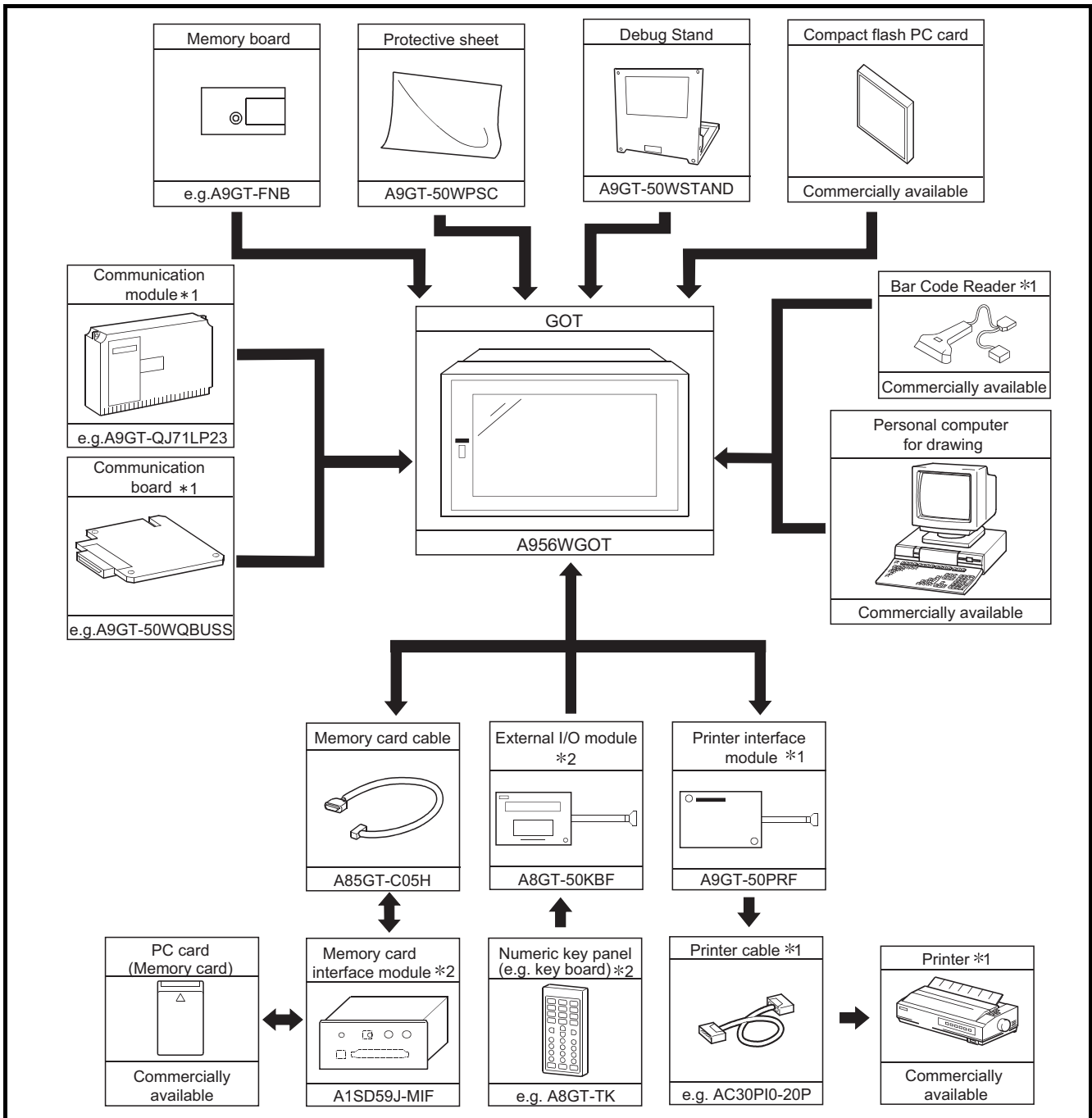

\*1 For details of the system configuration, refer to the [GOT-A900 Series User's Manual (Connection System Manual)].

\*2 For details on the system configuration, refer to the User's Manual of each module.

## 2.2 System Configuration of the GOT

Each GOT incorporates a different type of communication interface and, therefore, the connection mode differs from GOT to GOT used.

The connections modes allowed for each GOT are shown below.

Type	Bus connection		CPU direct Connection		MELSEC-NET connection	Computer link connection		CC-Link connection	Ethernet connection
	QCPU (Q mode)	A/QnA/ Motion controller CPU	RS-422 communication	RS-232C communication		RS-422 communication	RS-232C communication		
A950GOT	×	×	○	×	×	○	×	×	×
A951GOT-Q	○	×	×	×	×	×	×	×	×
A951GOT	×	○	×	×	×	×	×	×	×
A953GOT	×	×	×	○	×	×	○	×	×
A956GOT*1	○	○	×	×	○	×	×	○	○
A956WGO T*2	○	○	○	○	○	○	○	○	○

○: Connection possible ×: Connection not possible

\* 1 The A956GOT can be connected as shown above by the installation of the communication unit.

\* 2 The A956WGOT can be connected as shown above by the installation of the communication unit and the communication board.

\* 3 For details of each connection mode, refer to the GOT-A900 Series User's Manual (Connection System Manual).

## 2.3 Component List

### (1) List of Components Available for the A95\*GOT

Component	Type	Description
A950GOT (Built-in RS-422 communication interface)	A950GOT-TBD	High intensity TFT color liquid crystal, 256 colors, 1M byte built-in memory
	A950GOT-SBD	STN color liquid crystal, 8 colors, 1M byte built-in memory
	A950GOT-SBD-B	High intensity STN color liquid crystal, 8 colors, 1M built-in memory
	A950GOT-LBD	Monochrome liquid crystal, Monochrome, 1M byte built-in memory
	A950GOT-TBD-M3	High intensity TFT color liquid crystal, 256 colors, 3M byte built-in memory, compatible with optional OS
	A950GOT-SBD-M3	STN color liquid crystal, 8 colors, 3M byte built-in memory, compatible with optional OS
	A950GOT-SBD-M3-B	High intensity STN color liquid crystal, 8 colors, 3M built-in memory, compatible with optional OS
	A950GOT-LBD-M3	Monochrome liquid crystal, Monochrome, 3M byte built-in memory, compatible with optional OS

Component	Type	Description
A951GOT-Q (Built-in bus communication interface for QCPU (Q mode))	A951GOT-QTBD	High intensity TFT color liquid crystal, 256 colors,1M byte built-in memory
	A951GOT-QSBD	STN color liquid crystal, 8 colors,1M byte built-in memory
	A951GOT-QSBD-B	High intensity STN color liquid crystal, 8 colors, 1M built-in memory
	A951GOT-QLBD	Monochrome liquid crystal, Monochrome,1M byte built-in memory
	A951GOT-QTBD-M3	High intensity TFT color liquid crystal, 256 colors, 3M byte built-in memory, compatible with optional OS
	A951GOT-QSBD-M3	STN color liquid crystal, 8 colors, 3M byte built-in memory, compatible with optional OS
	A951GOT-QSBD-M3-B	High intensity STN color liquid crystal, 8 colors, 3M built-in memory, compatible with optional OS
	A951GOT-QLBD-M3	Monochrome liquid crystal, Monochrome, 3M byte built-in memory, compatible with optional OS
A951GOT (Built-in bus communication interface for A/QnA/Motion controller CPU)	A951GOT-TBD	High intensity TFT color liquid crystal, 256 colors,1M byte built-in memory
	A951GOT-SBD	STN color liquid crystal, 8 colors,1M byte built-in memory
	A951GOT-SBD-B	High intensity STN color liquid crystal, 8 colors, 1M built-in memory
	A951GOT-LBD	Monochrome liquid crystal, Monochrome,1M byte built-in memory
	A951GOT-TBD-M3	High intensity TFT color liquid crystal, 256 colors, 3M byte built-in memory, compatible with optional OS
	A951GOT-SBD-M3	STN color liquid crystal, 8 colors, 3M byte built-in memory, compatible with optional OS
	A951GOT-SBD-M3-B	High intensity STN color liquid crystal, 8 colors, 3M built-in memory, compatible with optional OS
	A951GOT-LBD-M3	Monochrome liquid crystal, Monochrome, 3M byte built-in memory, compatible with optional OS
A953GOT (Built-in RS-232C communication Interface)	A953GOT-TBD	High intensity TFT color liquid crystal, 256 colors,1M byte built-in memory
	A953GOT-SBD	STN color liquid crystal, 8 colors,1M byte built-in memory
	A953GOT-SBD-B	STN color liquid crystal, 8 colors, 1M built-in memory
	A953GOT-LBD	Monochrome liquid crystal, Monochrome,1M byte built-in memory
	A953GOT-TBD-M3	High intensity TFT color liquid crystal, 256 colors,3M byte built-in memory, compatible with optional OS
	A953GOT-SBD-M3	STN color liquid crystal, 8 colors,3M byte built-in memory, compatible with optional OS
	A953GOT-SBD-M3-B	High intensity STN color liquid crystal, 8 colors, 3M built-in memory, compatible with optional OS
	A953GOT-LBD-M3	Monochrome liquid crystal, Monochrome,3M byte built-in memory, compatible with optional OS
A956GOT (Built-in communication module Interface)	A956GOT-TBD	TFT color liquid crystal, 256 colors,1M byte built-in memory
	A956GOT-SBD	STN color liquid crystal, 8 colors,1M byte built-in memory
	A956GOT-SBD-B	High intensity STN color liquid crystal, 8 colors, 1M built-in memory
	A956GOT-LBD	Monochrome liquid crystal, Monochrome,1M byte built-in memory
	A956GOT-TBD-M3	High intensity TFT color liquid crystal, 256 colors,3M byte built-in memory, compatible with optional OS
	A956GOT-SBD-M3	STN color liquid crystal, 8 colors,3M byte built-in memory, compatible with optional OS
	A956GOT-SBD-M3-B	High intensity STN color liquid crystal, 8 colors, 3M built-in memory, compatible with optional OS
	A956GOT-LBD-M3	Monochrome liquid crystal, Monochrome,3M byte built-in memory, compatible with optional OS
Bus Connection module	A7GT-BUSS	For A956GOT, for bus connection, small connector type (For A/QnA/Motion controller CPU)
Multidrop bus connection module	A7GT-BUS2S	For A956GOT, for multidrop bus connection, small connector type (For A/QnA/Motion controller CPU)
Protective sheet	A9GT-50PSC	Transparent protective sheet for A95 * GOT
Backlight	A9GT-50LT	Backlight for A95 * GOT-SBD (-M3), A95 * GOT-LBD (-M3)



Component	Type	Description
Debug stand	A9GT-50STAND	Debug stand for A95 * GOT
Attachment	A85GT-95ATT	For replacement from A85 * GOT to A95 * GOT

1	OVERVIEW
2	SYSTEM CONFIGURATION
3	PERFORMANCE
4	NAMES OF THE PARTS AND THEIR SETTINGS
5	ROUGH PRE-OPERATION PROCEDURE
6	HANDLING
7	MAINTENANCE AND INSPECTION
8	EMC DIRECTIVE

(2) List of Components Available for the A956WGOT

Component	Type	Description
A956WGOT	A956WGOT-TBD	256color, 1M byte Built-in memory (Possible to expand to a maximum of 9M bytes by using a memory board), 24VDC
Bus connection board	A9GT-50QBUISS	For bus connection, small connector type (For Q (Q mode) CPU)
	A9GT-50WBUISS	For bus connection, small connector type (For A/QnA/Motion controller CPU)
Serial communication board	A9GT-50WRS2	For Direct connection to CPU/Computer link connection/Microcomputer connection and RS-232C connection
	A9GT-50WRS4	For Direct connection to CPU/Computer link connection/Microcomputer connection and RS-422 connection
Protective sheet	A9GT-50WPSC	Transparent protective sheet for A956WGOT
Debug stand	A9GT-50WSTAND	Debug stand for A956WGOT
Compact flash card	---	Commercially available Compact Flash PC card
Memory board	A9GT-FNB	Exclusively used for optional OS storage
	A9GT-FNB1M	For optional function OS storage + built-in memory extension, 1M byte
	A9GT-FNB2M	For optional function OS storage + built-in memory extension, 2M byte
	A9GT-FNB4M	For optional function OS storage + built-in memory extension, 4M byte
	A9GT-FNB8M	For optional function OS storage + built-in memory extension, 8M byte
	A9GT-QFNB	Exclusively used for optional OS storage (MELSEC-Q Ladder monitor compatible)
	A9GT-QFNB4M	For optional function OS storage + built-in memory extension, 4M byte (MELSEC-Q Ladder monitor compatible)
	A9GT-QFNB8M	For optional function OS storage + built-in memory extension, 8M byte (MELSEC-Q Ladder monitor compatible)

(3) List of Components Available for the A95\*GOT/A956WGOT

Component	Type	Description	
Bus Connection module	A9GT-BUSSU	For A956GOT/A956WGOT, for bus connection, small connector type (For A/QnA/Motion controller CPU)	
Multidrop bus connection module	A9GT-QBUS2SU	For A956GOT/A956WGOT, for multidrop bus connection, small connector type (For QCPU (Q mode))	
	A9GT-BUS2SU	For A956GOT/A956WGOT, for multidrop bus connection, small connector type (For A/QnA/Motion controller CPU)	
Data link module	A7GT-J71AP23	For A956GOT/A956WGOT, for MELSECNET(II) optical link connection, for use as local station	
	A7GT-J71AR23	For A956GOT/A956WGOT, for MELSECNET(II) coaxial link connection, for use as local station	
	A7GT-J71AT23B	For A956GOT/A956WGOT, for MELSECNET/B connection, for use as local station	
Network module	A9GT-QJ71LP23	For A956GOT/A956WGOT, for MELSECNET/10 optical loop network connection, for use as ordinary station *5	
	A9GT-QJ71BR13	For A956GOT/A956WGOT, for MELSECNET/10 coaxial bus network connection, for use as ordinary station *5	
	A7GT-J71LP23	For A956GOT/A956WGOT, for MELSECNET/10 optical loop network connection, for use as ordinary station *5	
	A7GT-J71BR13	For A956GOT/A956WGOT, for MELSECNET/10 coaxial bus network connection, for use as ordinary station *5	
CC-Link communication module	A8GT-J61BT13	For A956GOT/A956WGOT, for CC-Link connection, for use as intelligent device station	
	A8GT-J61BT15	For A956GOT/A956WGOT, for CC-Link connection, for use as remote device station	
Ethernet communication module	A9GT-J71E71-T	For A956GOT/A956WGOT, for Ethernet connection	
External I/O module	A8GT-50KBF	For external I/O equipment connection	
Numeric keypad panel	A8GT-TK	Data entry Numeric Keypad Panel	
Memory card interface module	A1SD59J-MIF	For PC card loading	
PC card	---	SRAM type PC card	*6 Refer to the relevant document
Printer interface module	A9GT-50PRF	For printer connection	
Printer	---	Printer compliant with ESC/P24-J84(ESC/P command compatible) *1 Hewlett Packard printers (PLC command compatible)	*6 Refer to the relevant document
Bar code reader	---	Commercially available bar-code reader	
Bus extension connector box	A9GT-QCNB	Used for connection of the QCPU (Q mode) long-distance bus.	
Bus connector conversion box	A7GT-CNB	For conversion from large type connector to small type connector (Used for connecting the CPU long-distance bus of the A/QnA Motion controller.)	

1 OVERVIEW  
2 SYSTEM CONFIGURATION  
3 PERFORMANCE  
4 NAMES OF THE PARTS AND THEIR SETTINGS  
5 ROUGH PRE-OPERATION PROCEDURE  
6 HANDLING  
7 MAINTENANCE AND INSPECTION  
8 EMC DIRECTIVE

Component	Type	Description
Bus connection cable for QCPU (Q mode)	QC06B	Cable length 0.6m
	QC12B	Cable length 1.2m
	QC30B	Cable length 3.0m
	QC50B	Cable length 5.0m
	QC100B	Cable length 10.0m
	A9GT-QC150BS	Cable length 15.0m
	A9GT-QC200BS	Cable length 20.0m
	A9GT-QC250BS	Cable length 25.0m
	A9GT-QC300BS	Cable length 30.0m
	A9GT-QC350BS	Cable length 35.0m
Bus connection cable	AC06B	Cable length 0.6m
	AC12B	Cable length 1.2m
	AC30B	Cable length 3.0m
	AC50B	Cable length 5.0m
	AC12B-R	Right angle, cable length 1.2m
	AC30B-R	Right angle, cable length 3.0m
	AC50B-R	Right angle, cable length 5.0m
	A1SC07B	Cable length 0.7m
	A1SC12B	Cable length 1.2m
	A1SC30B	Cable length 3.0m
	A1SC50B	Cable length 5.0m
	A8GT-C12NB	Cable length 1.2m
	A8GT-C30NB	Cable length 3.0m
	A8GT-C50NB	Cable length 5.0m
	A1SC-C05NB	Cable length 0.5m
	A1SC-C07NB	Cable length 0.7m
	A1SC-C30NB	Cable length 3.0m
	A1SC-C50NB	Cable length 5.0m
	A8GT-C100EXSS	Cable length 10.0m
	A8GT-C200EXSS	Cable length 20.0m
	A8GT-C300EXSS	Cable length 30.0m
	A8GT-C100EXSS-1	Cable length 10.0m
	A8GT-C200EXSS-1	Cable length 20.0m
	A8GT-C300EXSS-1	Cable length 30.0m
	A8GT-C100BS	Cable length 10.0m
	A8GT-C200BS	Cable length 20.0m
	A8GT-C300BS	Cable length 30.0m
	A370C12B-S1	Cable length 1.2m
	A370C25B-S1	Cable length 2.5m
	A370C12B	Cable length 1.2m
A370C25B	Cable length 2.5m	
A9GT-J2C10B	Cable length 1.0m	
		For connection between GOT and QCPU (Q mode)
		For connection between GOT and GOT
		For connection between GOT and QCPU (Q mode) (A9GT-QCNB required)
		For connection between GOT and GOT
		For connection between QnACPU Type/AnCPU Type/motion controller CPU and A7GT-CNB
		For connection between GOT and QnASCPU Type/AnSCPU Type/motion controller CPU
		For connection between GOT and GOT
		For connection between QnASCPU Type/AnSCPU Type/motion controller CPU and A7GT-CNB
		For connection between GOT and QnACPU Type/AnCPU Type/motion controller CPU
		For connection between GOT and QnASCPU Type/AnSCPU Type/motion controller CPU
		For connection between GOT and A7GT-CNB
		For connection between GOT and QnASCPU Type/AnSCPU Type/motion controller CPU
		For connection between GOT and A7GT-CNB *7
		For connection between GOT and GOT
		For connection between GOT and motion controller CPU
		For connection between motion controller CPU and A7GT-CNB
		For connection between GOT and A0J2HCPU

Component	Type	Description	
RS-422 cable	AC30R4-25P	Cable length 3m (D-sub 25-pin at both ends)	For connection between GOT and A/QnACPU
	AC100R4-25P	Cable length 10m (D-sub 25-pin at both ends)	
	AC300R4-25P	Cable length 30m (D-sub 25-pin at both ends)	For connection between GOT and FXCPU
	---	For connection between GOT and computer link module *2	
RS-232C cable *3	QC30R2	Cable length 3m	For connection between GOT and QCPU
	AC30R2-9P	Cable length 3m (D-sub 9-pin, D-sub 25-pin)	For connection between GOT and personal computer for data transfer
	AC30R2-9SS	Cable length 3m (D-sub 9-pin at both ends)	
	AC30R2	Cable length 3m (D-sub 25-pin at both ends)	For connection between GOT and personal computer for data transfer (9-pin conversion connector required)
	AC30N2A	Cable length 3m (D-sub 25-pin at both ends)	
	---	For connection between GOT and computer link module *2	
	---	For connecting the GOT with the power supply unit of the bar code reader *4	
Printer cable *4	AC30PIO-20P	Cable length 3m	For connection between GOT and printer
GT Designer	---	Screen creation software for GOT900 series	
GT Designer 2	---		

- \*1 The printer of ESC/P raster specifications such as the PM series cannot be connected and used with the GOT.
- \*2 The RS-422/RS-232C cable for use between GOT and computer link module should be fabricated on the user side by referring to the [GOT-A900 Series User's Manual (Connection System Manual)].
- \*3 The RS-232C cable may be fabricated by the user.  
The RS-232C cable can also be fabricated by the user.  
Refer to the following manual for details of the cable specifications.  
When GT Designer is used: GT Works Version □/GT Designer Version □ Reference Manual  
When GT Designer2 is used: GT Designer2 Version □ Operating Manual
- \*4 The printer cable may be fabricated by the user.  
Refer to [A9GT-50PRF type Printer interface module User's Manual] for full information on the specifications needed to fabricate the cable.
- \*5 For the A9GT-QJ71LP23 and A9GT-QJ71BR13, the device range (QCPU, QnACPU, ACPU) that can be monitored changes depending on the communication driver.  
When the A7GT-J71LP23 or A7GT-J71BR13 is mounted, only the device range of the AnA can be monitored.
- \*6 Relevant document Some devices have been concluded to be applicable for GOT900 series by Mitsubishi.  
For details of the devices, refer to the relevant document "List of valid devices applicable for GOT900 series" (Technical bulletin T10-0028).  
Please contact your local Mitsubishi representative for the document, if necessary.  
The GOT may not operate correctly if a device other than described in the document is used.
- \*7 The A8GT-C100EXSS-1, A8GT-C200EXSS-1, and A8GT-C300EXSS-1 are composed of the A8GT-EXCNB (0.5m) and the  
A8GT-C100BS (10m), A8GT-C200BS (20m), and A8GT-C300BS (30m) respectively.  
When calculating the cable length, the A8GT-EXCNB's cable length can be ignored.

## 2.4 Software Packages to be Used

When a GOT is used, a software package of the applicable version or later is required.  
The versions of the software packages required for each GOT are shown below.

Type	Compatible software package		
	GT Works 2 GT Designer 2	GT Works GT Designer	
A950GOT-TBD(-M3)	SW1D5C-GTWK2-E A or later SW1D5C-GTD2-E A or later	SW0D5C-GTWORKS-E Version A or later, SW4D5C-GOTR-PACKE Version A or later	
A950GOT-SBD(-M3)		SW0D5C-GTWORKS-E Version A or later, SW1D5C-GOTRE-PACK Version H or later	
A950GOT-LBD(-M3)		SW0D5C-GTWORKS-E Version A or later, SW4D5C-GOTR-PACKE Version A or later	
A951GOT-QTBD(-M3)		SW0D5C-GTWORKS-E Version A or later, SW3D5C-GOTRE-PACK Version C or later	
A951GOT-QSBD(-M3)		SW0D5C-GTWORKS-E Version A or later, SW4D5C-GOTR-PACKE Version A or later	
A951GOT-QLBD(-M3)		SW0D5C-GTWORKS-E Version A or later, SW1D5C-GOTRE-PACK Version H or later	
A951GOT-TBD(-M3)		SW0D5C-GTWORKS-E Version A or later, SW4D5C-GOTR-PACKE Version A or later	
A951GOT-SBD(-M3)		SW0D5C-GTWORKS-E Version A or later, SW1D5C-GOTRE-PACK Version H or later	
A951GOT-LBD(-M3)		SW0D5C-GTWORKS-E Version A or later, SW4D5C-GOTR-PACKE Version A or later	
A953GOT-TBD(-M3)		SW0D5C-GTWORKS-E Version A or later, SW1D5C-GOTRE-PACK Version H or later	
A953GOT-SBD(-M3)		SW0D5C-GTWORKS-E Version A or later, SW1D5C-GOTRE-PACK Version H or later	
A953GOT-LBD(-M3)		SW0D5C-GTWORKS-E Version A or later, SW4D5C-GOTR-PACKE Version A or later	
A956GOT-TBD(-M3)		SW0D5C-GTWORKS-E Version A or later, SW1D5C-GOTRE-PACK Version H or later	
A956GOT-SBD(-M3)		SW0D5C-GTWORKS-E Version A or later, SW1D5C-GOTRE-PACK Version H or later	
A956GOT-LBD(-M3)		SW5D5C-GTWORKS-E Version K or later, SW5D5C-GOTR-PACKE Version K or later	
A956WGOT-TBD			
A950GOT-SBD(-M3)-B		SW1D5C-GTWK2-E Version Q or later SW1D5C-GTD2-E Version Q or later	SW5D5C-GTWORKS-E Version Q or later SW5D5C-GOTRE-PACK Version Q or later
A951GOT-QSBD(-M3)-B			
A951GOT-SBD(-M3)-B			
A953GOT-SBD(-M3)-B			
A956GOT-SBD(-M3)-B			

## 2.5 Unusable Conventional Products

The following conventional products cannot be used with this GOT.

Component	Type
Bus connection board	A9GT-BUSS, A9GT-BUS2S
Bus connection module	A7GT-BUS, A9GT-BUS2
Serial communication board	A9GT-RS2, A9GT-RS4
Serial communication module	A8GT-RS2, A8GT-RS4
Backlight	A9GT-70LTT, A9GT-70LTS, A9GT-70LTTB, A9GT-80LTT, A8GT-70LTT, A8GT-70LTS, A8GT-50LT
Ladder monitoring cassette	A8GT-MCAM
Extension memory cassette	A8GT-MCA1MFDW, A8GT-MCA2MFDW, A8GT-MCA3MFDW
Extension memory board	A9GT-FNB, A9GT-FNB1M, A9GT-FNB2M, A9GT-FNB4M
Protective sheet	A9GT-80PSC, A9GT-80PSCL, A9GT-70PSC, A9GT-70PSCL, A9GT-60PSC, A9GT-60PSCL, A8GT-70PSCE, A8GT-70PSNE, A8GT-70PSCS, A8GT-70PSNS, A8GT-50PSC, A8GT-50PSN
Printer interface module	A8GT-70PRF, A8GT-50PRF
External I/O module	A9GT-70KBF, A8GT-70KBF
Debug stand	A9GT-80STAND, A9GT-70STAND, A8GT-70STAND, A8GT-50STAND
Option module mounting fixture	A8GT-50STE

## 2.6 Notes on Q4ARCPU Duplex System

This section describes the notes on the connecting of the Q4ARCPU with the GOT, as follows:

- (1) Notes on the additional base for duplex system at the final stage:  
To connect the duplex system with the GOT via the bus, connect the GOT with the additional base for duplex system (A68RB) that is provided at the final stage of the duplex system. To use the additional base for duplex system, please apply that of the Version B or after.
  - In the following configurations the GOT will not operate normally as specified.
    - (a) The configuration in which the GOT is connected with the fundamental base for the duplex system (A32RB, A33RB) is connected via the bus.
    - (b) The configuration in which the GOT is connected with the additional base (A68RB) for duplex system of Version A is connected via the bus.
  - To check and confirm the version of the additional base for duplex system, please refer to the DATE column on the rating plate that is adhered to the part as shown in the illustration below.

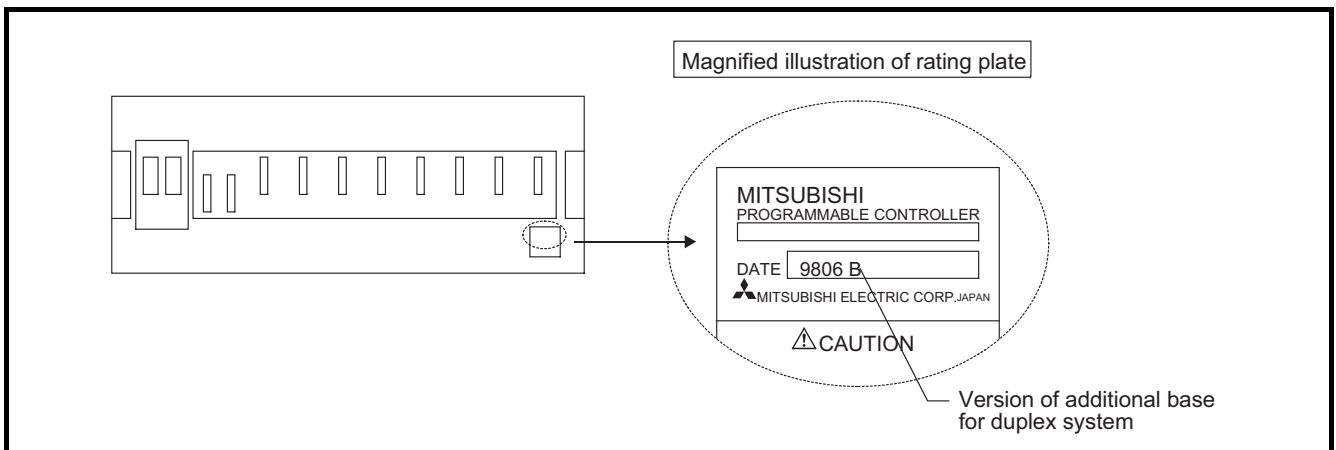

- (2) Notes on 5V DC supply for the additional base (A68RB) for duplex system at the final stage: 220mA of current to be consumed will be supplied from the additional base for duplex system at the final stage to the GOT bus interface, if the GOT power supply is off and the power supply for the power supply module mounted on the additional base for duplex system at the final stage is on. Therefore, please make sure that the 5V DC consumption (8A) of the power supply module will not be exceeded by the sum of the value of the current consumption of the input/output module and special function module that are mounted on the additional base for duplex system at the final stage and the value of the current consumption (220mA) of the GOT bus interface.



Power on the GOT-A900 series and Q4ARCPU duplex system in the following order.

- (1) Power on the GOT-A900 series.
- (2) 1 to 2 seconds after power-on of the GOT-A900 series, power on the Q4ARCPU duplex system.

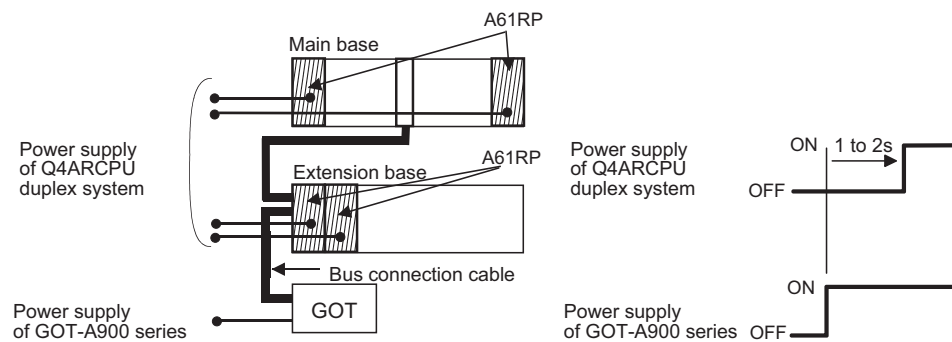

It is recommended to switch power on with an external circuit configured.

If power is not switched on in the order as specified in the restriction, the Q4ARCPU duplex system will not start up in system A but will start up in system B before it starts control.



# 3 PERFORMANCE

## 3.1 General Specifications

The general specifications of the GOT are indicated below.

Item	Specifications					
Operating ambient temperature	Display section	A95*GOT: 0 to 40 °C A956WGOT: 0 to 55 °C				
	Other than display section	0 to 55 °C				
Storage ambient temperature	-20 to 60 °C					
Operating ambient humidity	10 to 90 % RH, non-condensing					
Storage ambient humidity	10 to 90 % RH, non-condensing					
Vibration resistance	Conforms to JIS B3502 and IEC 61131-2	In case of intermittent vibration	Frequency	Acceleration	Amplitude	Sweep Count 10 times in each of X, Y and Z directions (for 80 minutes)
			10 to 57 Hz	---	0.075 mm	
		In case of continuous vibration	57 to 150 Hz	9.8 m/s <sup>2</sup>	---	
			10 to 57 Hz	---	0.035 mm	
57 to 150 Hz	4.9 m/s <sup>2</sup>	---				
Shock resistance	Conforms to JIS B3502, IEC 61131-2 (147 m/s <sup>2</sup> , 3 times in each of X, Y and Z directions)					
Operating atmosphere *3	No corrosive gas					
Operating altitude	2000 m(6562 ft) max.					
Installation site	Inside control box					
Overtoltage category *1	II or less					
Contamination level *2	2 or less					

\*1 Indicates the element in the distribution system between the public electricity grid and the mechanical equipment inside the premises that the relevant device is assumed to be connected to.

Category II applies to devices such as those that draw their power supply from fixed installations.

The surge voltage withstand capability of devices with ratings up to 300V is 2,500V.

\*2 This index gives a measure of the incidence of conductive materials in the environment in which the device is used.

A contamination level of 2 indicates an environment in which there is only contamination by non-conducting materials, but due to occasional condensation, conductivity may occur.

\*3 Please do not use or store GOT in an environment with atmospheric pressure greater than the atmospheric pressure at sea level (0m).

There is a possibility errors may occur if this point is not observed.

## 3.2 Performance Specifications

(1) The performance specifications of the A951GOT-Q are shown below.

Item		Specifications			
		A951GOT-QTBD (-M3)	A951GOT-QSBD (-M3)-B	A951GOT-QSBD (-M3)	A951GOT-QLBD (-M3)
Display section		For details of display specifications, refer to Section 3.2 (4)			
Touch panel	Number of touch keys	300 points (15 lines × 20 columns)			
	Key size	Minimum 16 × 16 dots (per key)			
	Repeat function	No			
Memory *1	Type	Flash ROM			
	Application	For monitor screen data storage, for OS storage			
	Capacity	1M byte built-in (user area) (-M3 has 3M bytes and is compatible with optional OS)			
Reference value for data transmission time (For RS-232C communication)		When installing OS: 640 to 760 seconds (For basic functions, BUS driver and system monitor (approx. 1.3Mbytes)) When downloading screen data: 330 to 570 seconds (For approx. 30 screens (approx. 600kbytes))			
Interface Built into main unit		Bus communication interface for QCPU (Q mode) 1 channel			
Option module interface		for option module loading, 1 channel			
RS-232C interface		For connection of personal computer, for bar-code reader connection, 1 channel			
Buzzer output		Single tone (tone length adjustable)			
Life *2	Touch key	1 million times or more (operating force 0.98N max.)			
	Built-in memory	Number of write times: 100,000 times			
Environmental protective structure *3		Front section: Equivalent to IP67/NEMA4 Panel inside: IP2X			
Outline dimensions		TBD(-M3)/SBD(-M3)-B: 164.5 (6.48) (W) × 136 (5.35) (H) × 65 (2.56) (D) mm (inch) SBD(-M3)/LBD(-M3) : 164.5 (6.48) (W) × 136 (5.35) (H) × 57 (2.24) (D) mm (inch)			
Panel cutting dimensions		156 (6.14) (W) × 123.5 (4.86) (H) mm (inch)			
Weight		0.71 (1.56) kg(lb)	0.75 (1.65) kg (lb)	0.67 (1.47) kg (lb)	
Compatible software package	GT Works2 GT Designer2	Supported from the first version (Version 1.00A)	Supported from the SW1D5C-GTWK2-E Version 1.17T or later/ SW1D5C-GTD2-E Version 1.17T or later Supported from the SW2D5C-GTWK2-E Version 2.04E or later/ SW2D5C-GTD2-E Version 2.04E or later	Supported from the first version (Version 1.00A)	
	GT Works GT Designer	Supported from the SW0D5C-GTWORKS-E Version A or later/ SW4D5C-GOTRE-PACK Version A or later	No support	Supported from the SW0D5C-GTWORKS-E Version A or later/SW3D5C-GOTRE-PACK Version C or later	

\*1 The built-in memory is ROM which allows old data to be overwritten by new data. (Data backup power supply is not needed.)

\*2 When parts must be changed, consult your sales representative.

\*3 The environmental protective structure (IP rating) differs depending on the hardware version of GOT.

Item		Specification		
		A951GOT-QTBD(-M3)	A951GOT-QSBD(-M3) A951GOT-QLBD(-M3)	A951GOT-QSBD(-M3)-B
Environmental protective structure	Front section: Equivalent to IP65 Panel inside: IP2X	Hardware version A or later		---
	Front section: Equivalent to IP67/NEMA4 Panel inside: IP2X	Hardware version B (Jul., 2001) or later	Hardware version H (Jul., 2001) or later	Hardware version A or later

1	OVERVIEW
2	SYSTEM CONFIGURATION
3	PERFORMANCE
4	NAMES OF THE PARTS AND THEIR SETTINGS
5	ROUGH PRE-OPERATION PROCEDURE
6	HANDLING
7	MAINTENANCE AND INSPECTION
8	EMC DIRECTIVE

(2) The performance specifications of the A950/951/953/956GOT are shown below

Item		Specifications			
		A950GOT-TBD(-M3) A950GOT-SBD(-M3)-B A950GOT-SBD(-M3) A950GOT-LBD(-M3)	A951GOT-TBD(-M3) A951GOT-SBD(-M3)-B A951GOT-SBD(-M3) A951GOT-LBD(-M3)	A953GOT-TBD(-M3) A953GOT-SBD(-M3)-B A953GOT-SBD(-M3) A953GOT-LBD(-M3)	A956GOT-TBD(-M3) A956GOT-SBD(-M3)-B A956GOT-SBD(-M3) A956GOT-LBD(-M3)
Display section		For details of display specifications, refer to Section 3.2 (4)			
Touch panel	Number of touch keys	300 points (15 lines × 20 columns)			
	Key size	Minimum 16 × 16 dots (per key)			
	Repeat function	No			
Memory *1	Type	Flash ROM			
	Application	For monitor screen data storage, for OS storage			
	Capacity	1M byte built-in (user area) (-M3 has 3M bytes and is compatible with optional OS)			
Reference value for data transmission time (For RS-232C communication)		When installing OS : 640 to 760 seconds (For basic functions, BUS driver and system monitor (approx. 1.3Mbytes)) When downloading screen data : 330 to 570 seconds (For approx. 30 screens (approx. 600kbytes))			
Interface Built into main unit		For RS-422 communication 1 channel	For bus communication 1 channel	For RS-232C communication 1 channel	For communication module mounting 1 channel
Option module interface		for option module loading, 1 channel			
RS-232C interface		For connection of personal computer, for bar-code reader connection, 1 channel			
Buzzer output		Single tone (tone length adjustable)			
Life *2	Touch key	1 million times or more (operating force 0.98N max.)			
	Built-in memory	Number of write times: 100,000 times			
Environmental protective structure *3		Front section: Equivalent to IP67/NEMA4 Panel inside: IP2X			
Outline dimensions		SBD(-M3)-B, TBD(-M3): 164.5 (6.48) (W) × 136 (5.35) (H) × 65 (2.56) (D) mm (inch) SBD(-M3)/LBD(-M3) : 164.5 (6.48) (W) × 136 (5.35) (H) × 57 (2.24) (D) mm (inch)			
Panel cutting dimensions		156 (6.14) (W) × 123.5 (4.86) (H) mm (inch)			
Weight		TBD: 0.71 (1.56) kg(lb) SBD/LBD: 0.67 (1.47) kg(lb) SBD(-M3)-B: 0.75 (1.65) kg(lb)			
Compatible software package	GT Works2 GT Designer2	TBD(-M3)/SBD(-M3)/LBD (M-3) : Supported from the first version (Version 1.00A) SBD (-M3)-B : Supported from the SW1D5C-GTWK2-E Version 1.17T or later/ SW1D5C-GTD2-E Version 1.17T or later Supported from the SW2D5C-GTWK2-E Version 2.04E or later/ SW2D5C-GTD2-E Version 2.04E or later			
	GT Works GT Designer	TBD(-M3) : Supported from the SW0D5C-GTWORKS-E Version A or later/SW4D5C-GOTRE - PACK Version A or later SBD (-M3)-B : No support SBD(-M3)/LBD (M-3) : Supported from the SW0D5C-GTWORKS-E Version A or later/SW1D5C-GOTRE - PACK Version H or later			

\*1 The ROM which allows old data to be overwritten by new data. (Data backup power supply is not needed.)

\*2 When parts must be changed, consult your sales representative.

\*3 The environmental protective structure (IP rating) differs depending on the hardware version of GOT.

		Specification				
		A950GOT-TBD (-M3)	A950GOT-SBD (-M3)		A956GOT-SBD (-M3)	A950GOT-SBD (-M3)-B
Item		A951GOT-TBD (-M3)	A950GOT-LBD (-M3)	A953GOT-SBD (-M3)	A956GOT-SBD (-M3)	A951GOT-SBD (-M3)-B
		A953GOT-TBD (-M3)	A951GOT-SBD (-M3)	A953GOT-LBD (-M3)	A956GOT-LBD (-M3)	A953GOT-SBD (-M3)-B
		A956GOT-TBD (-M3)	A951GOT-LBD (-M3)			A956GOT-SBD (-M3)-B
Environmental protective structure	Front section: Equivalent to IP65 Panel inside: IP2X	Hardware version A or later				---
	Front section: Equivalent to IP67/NEMA4 Panel inside: IP2X	Hardware version B (Jul., 2001) or later	Hardware version L (Jul., 2001) or later	Hardware version M (Jul., 2001) or later	Hardware version K (Jul., 2001) or later	Hardware version A or later

1	OVERVIEW
2	SYSTEM CONFIGURATION
3	PERFORMANCE
4	NAMES OF THE PARTS AND THEIR SETTINGS
5	ROUGH PRE-OPERATION PROCEDURE
6	HANDLING
7	MAINTENANCE AND INSPECTION
8	EMC DIRECTIVE

(3) The performance specifications of the A956WGOT are shown below.

Item		Specifications
		A956WGOT-TBD
Display section		For details of display specifications, refer to Section 3.2 (4)
Touch panel	Number of touch keys	450 points (15 lines × 30 columns)
	Key size	Minimum 16 × 16 dots (per key), (8 × 16 only for bottom line)
	Repeat function	No
Memory *1	Type	Flash ROM
	Application	For monitor screen data storage, for OS storage
	Capacity	1M byte built-in (user area), max. 8M bytes increasable
Reference value for data transmission time (For RS-232C communication)		When installing OS : 640 to 760 seconds (For basic functions, BUS driver and system monitor (approx. 1.3Mbytes)) When downloading screen data : 330 to 570 seconds (For approx. 30 screens (approx. 600kbytes))
Communication board slot *2		For communication board loading, 1 slot
Communication module interface*2		For communication module loading, 1 channel
Option module interface		For option module loading, 1 channel
Compact flash card interface		For Compact flash PC card loading, 1 channel
Memory board slot		For memory board loading, 1 slot
RS-232C interface		For connection of personal computer, for bar-code reader connection, 1 channel
Buzzer output		Single tone (tone length adjustable)
Life *3	Touch key	1 million times or more (operating force 0.98N max.)
	Built-in memory	Number of write times: 100,000 times
Environmental protective structure		Front section: Equivalent to IP67/NEMA4 Panel inside: IP2X
Outline dimensions		215 (8.46) (W) × 133 (5.24) (H) × 70.8 (2.79) (D) mm (inch)
Panel cutting dimensions		205.5 (8.09) (W) × 123.5 (4.86) (H) mm (inch)
Weight		1.05 (2.31) kg (lb)
Compatible software package *4		SW5D5C-GTWORKS-E Version K or later, SW5D5C-GOTR-PACKE Version K or later

\*1 The built-in FLASH ROM memory allows old data be overwritten by new data. (Data backup power supply is not needed.)

\*2 Note that either of the communication board slot and communication module interface may only be used.

\*3 When parts must be changed, consult your sales representative.

\*4 GT Works2 and GT Designer2 are compatible, starting with the initial products (Version 1.00A).

#### (4) Display specifications

Item	Specifications					
	A950GOT-TBD(-M3) A951GOT-QTBD(-M3) A951GOT-TBD(-M3) A953GOT-TBD(-M3) A956GOT-TBD(-M3)	A950GOT-SBD(-M3)-B A951GOT-QSBD(-M3)-B A951GOT-SBD(-M3)-B A953GOT-SBD(-M3)-B A956GOT-SBD(-M3)-B	A950GOT-SBD(-M3) A951GOT-QSBD(-M3) A951GOT-SBD(-M3) A953GOT-SBD(-M3) A956GOT-SBD(-M3)	A950GOT-LBD(-M3) A951GOT-QLBD(-M3) A951GOT-LBD(-M3) A953GOT-LBD(-M3) A956GOT-LBD(-M3)	A956WGOT-TBD *1, *2	
Display	Type	High intensity TFT color liquid crystal	High intensity STN color liquid crystal	STN color liquid crystal	Monochrome liquid crystal	High intensity TFT color liquid crystal
	Screen size	6 type				7 type
	Resolution	320 × 240 pixels				480 × 234 pixels
	Display size	115 (4.5) × 86 (3.4) mm (inch)				155.52 (6.12) × 87.75 (3.45) mm (inch)
	Display color	256 colors	8 colors		2 monochrome colors *7	256 colors
	Intensity	350cd/m <sup>2</sup>	350cd/m <sup>2</sup>	110cd/m <sup>2</sup>	200cd/m <sup>2</sup>	300cd/m <sup>2</sup>
	View angle	Left/Right: 65° Top: 65° Bottom: 40°	Left/Right: 50° Top: 50° Bottom: 60°	Left/Right: 50° Top: 45° Bottom: 60°	Left/Right: 30° Top: 20° Bottom: 30°	Left/Right: 65° Top: 40° Bottom: 65°
Backlight	Cold-cathode tube backlight (Backlight OFF/Screen saving time settings are available.)					
Life *4	Display *5 *6	50,000h (Operating ambient temperature: 25°)				
	Backlight *5	50,000h *3	75,000h *3	40,000h	50,000h *3	
Replacement backlight	---		A9GT-50LT		---	

\*1 If you run the monitor with A956WGOT, the screen may flicker depending on the type of object/shape fill pattern used when creating images.

This is due to the specifications of the LCD panel and is not a malfunction.

Be sure to check the combination of the type of pattern and color on the machine before using.

For patterns likely to flicker and countermeasures against flickers, refer to the PDF manual stored in the used drawing software.

\*2 Depending on the display color combination, the visibility of the screen may be lower from certain viewpoints.

Before using, check the color combination with the machine installed in the usage environment.

By designating bright colors for the basic color types, you can decrease the chances of this phenomenon occurring.

\*3 For A95\*GOT-(Q)TBD(-M3), A95\*GOT-(Q)SBD(-M3)-B and A956WGOT the backlight needs not be replaced, as they include a backlight of increased life.

\*4 When parts must be changed, consult your sales representative.

\*5 The screen saving/back light OFF function of GOT is extended, thus reducing burning prevention of the display panel and extending longevity of the back light.

\*6 Bright dots (always lit) and dark dots (unlit) may appear on a liquid crystal display panel. It is impossible to completely avoid this symptom, as the liquid crystal display comprises of a great number of display elements. Please note that these dots appear due to its characteristic and are not caused by product defect.

\*7 A screen created with GT Designer2 is displayed with reversing (white/black) on GOT.

The same display image as a screen created with GT Designer2 can be set for the display on GOT with [Setup] of the utility.

- When setting [Reverse display] to [Yes]: The display is the same as one created with GT Designer2.

- When setting [Reverse display] to [No]: The reversed (white/black) display of a screen created with GT Designer2 is displayed.

For how to operate the utility, refer to the GOT-A900 Series Operating Manual (Extended Option Functions Manual).

## 3.3 Power Supply Specifications

Item	Specifications		
	A950GOT, A951GOT-Q, A951GOT, A953GOT	A956GOT	A956WGOT
Input power supply voltage	24VDC (+10%, -15%)		
Input max. power	12W	16W	22W
Inrush current	40Ap, max. (26.4VDC, max. load)		
Permissible instantaneous power failure time	1 ms (19.2VDC or more)		
Noise immunity	By noise simulator of 500Vp-p noise voltage, 1_s noise width and 25 to 60Hz noise frequency		
Dielectric withstand voltage	500VAC for 1 minute across DC external terminals and earth		
Insulation resistance	10M $\Omega$ or larger by insulation resistance tester		
Applicable wire size	0.75 to 2 mm <sup>2</sup>		
Applicable solderless terminal	RAV1.25-3, V2-S3.3, V2-N3A, FV2-N3A		
Applicable tightening torque (Terminal block terminal screw)	59 to 88 N · cm <sup>2</sup>		

### **Remark**

When an instantaneous power failure occurs for the time exceeding the permissible instantaneous power failure time in the 24VDC power supply, the GOT may be reset. In such a case, the GOT will automatically return and start communicating.

As the communication between the GOT and PLC is stopped when an instantaneous power failure occurs, some object functions may not be performed normally.



# 4 NAMES OF THE PARTS AND THEIR SETTINGS

(1) Names of the Parts and Their Settings of the A95\*GOT are indicated below.

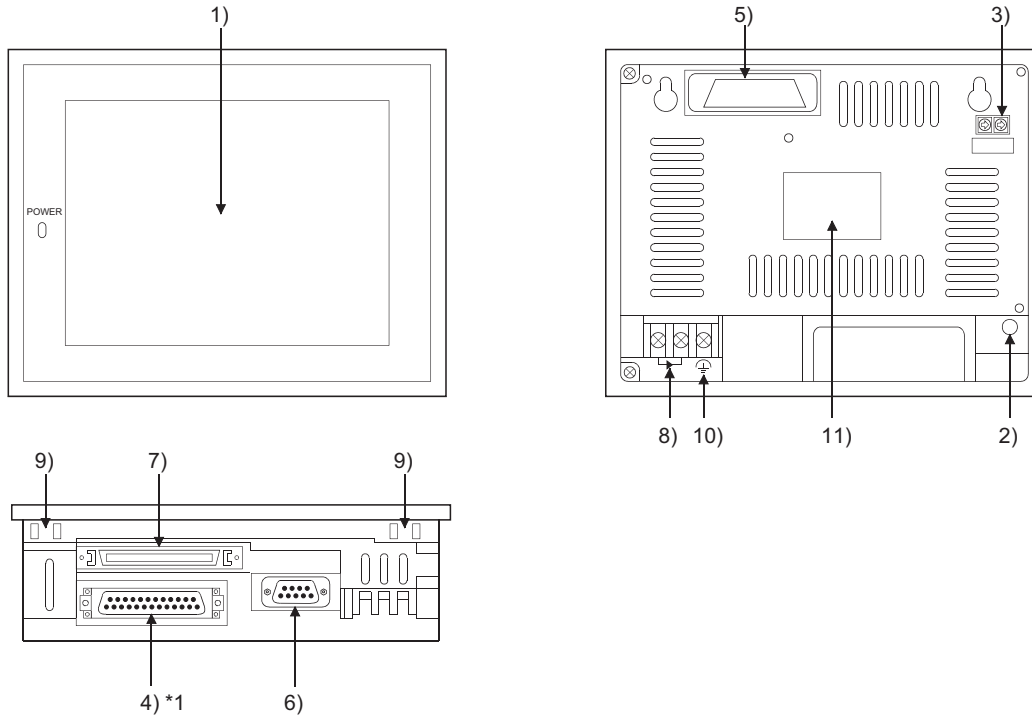

\*1: The shape of the interface section changes depending on the GOT.

No.	Name	Description
1)	Display section	Shows the screen
2)	Reset button	Used to reset the hardware of the GOT (invalid for bus connection)
3)	Extension number setting switch, (A951GOT only)	Used to set the extension number for GOT assignment 1 to 7 : Extension number 8, 9, 0 : Must not be used
	I/O slot setting switch (A951GOT only)	Used to set the I/O slot number for GOT assignment 0 to 7 : I/O slot number 8, 9 : Must not be used
4)	RS-422 communication interface (A950GOT only)	For RS-422 communication connection (D-sub 25-pin female metric screw type)
	Bus communication interface for QCPU (Q mode) (A951GOT only)	For bus connection cable connection (For QCPU (Q mode))
	Bus communication interface (A951GOT only)	For bus communication cable connection (For A/QnA/Motion controller CPU)
	RS-232C communication interface (A953GOT only)	For RS-232C communication cable connection (D-sub 9-pin male inch screw type)
5)	Communication module interface (A956GOT only)	Interface for loading the communication module
6)	RS-232C interface	For connection of personal computer For connecting the bar code reader (D-sub 9-pin male inch screw type)
7)	Option module interface	For connection Printer I/F module, Memory card I/F module, External I/O module
8)	Terminal block	For power input
9)	Mounting fixture fitting portion	For mounting fixture fitting
10)	Ground terminal	For earthing (For safety, please make sure to ground this terminal.)
11)	Rating plate	---

(2) Names of the Parts and Their Settings of the A956WGOT are indicated below.

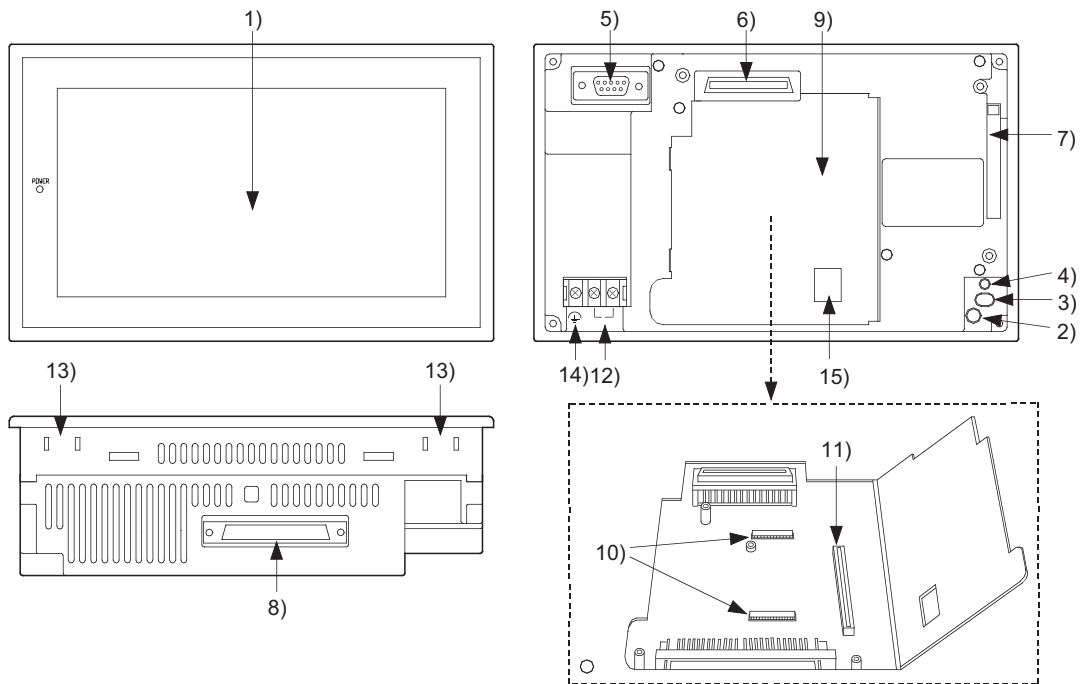

No.	Name	Description
1)	Display section	Shows the screen
2)	Reset button	Used to reset the hardware of the GOT (invalid for bus connection)
3)	Compact flash PC card access switch	Used to set the condition of access to the compact flash PC card when it is loaded during power-on (Factory-set to OFF) OFF :Access from GOT to compact flash PC card inhibited ON :Access from GOT to compact flash PC card enabled (When a memory card interface unit is used, a compact flash PC card cannot be used. Therefore, turn this switch OFF.)
4)	Compact flash PC card LED	Indicates whether the compact flash PC card may be loaded/unloaded or not OFF :Compact flash PC card may be loaded/unloaded (When switch 3 is OFF) ON :Compact flash PC card must not be loaded/unloaded (When switch 3 is ON)
5)	RS-232C interface	For connection of personal computer For connecting the bar code reader
6)	Communication module interface	Interface for communication module loading
7)	Compact flash card slot	Slot for Compact flash PC card loading
8)	Option module interface	For connection Printer I/F module, Memory card I/F module, External I/O module
9)	Slot cover	Cover of the memory board slot and the communication board slot
10)	Memory board slot	Slot for memory board loading
11)	Communication board slot	Slot for communication board loading
12)	Terminal block	For power input
13)	Mounting fixture fitting portion	For mounting fixture fitting
14)	Ground terminal	For earthing (For safety, please make sure to ground this terminal.)
15)	Bus connection board setting switch confirmation hole	For confirming the extension number of the I/O slot number set with the bus connection board (If you are not using the A9GT-50WBUS, it is possible to attach the seal included with the GOT main unit to cover the hole.)

# 5 ROUGH PRE-OPERATION PROCEDURE

This chapter gives a rough procedure to be performed before starting the operation of the GOT.

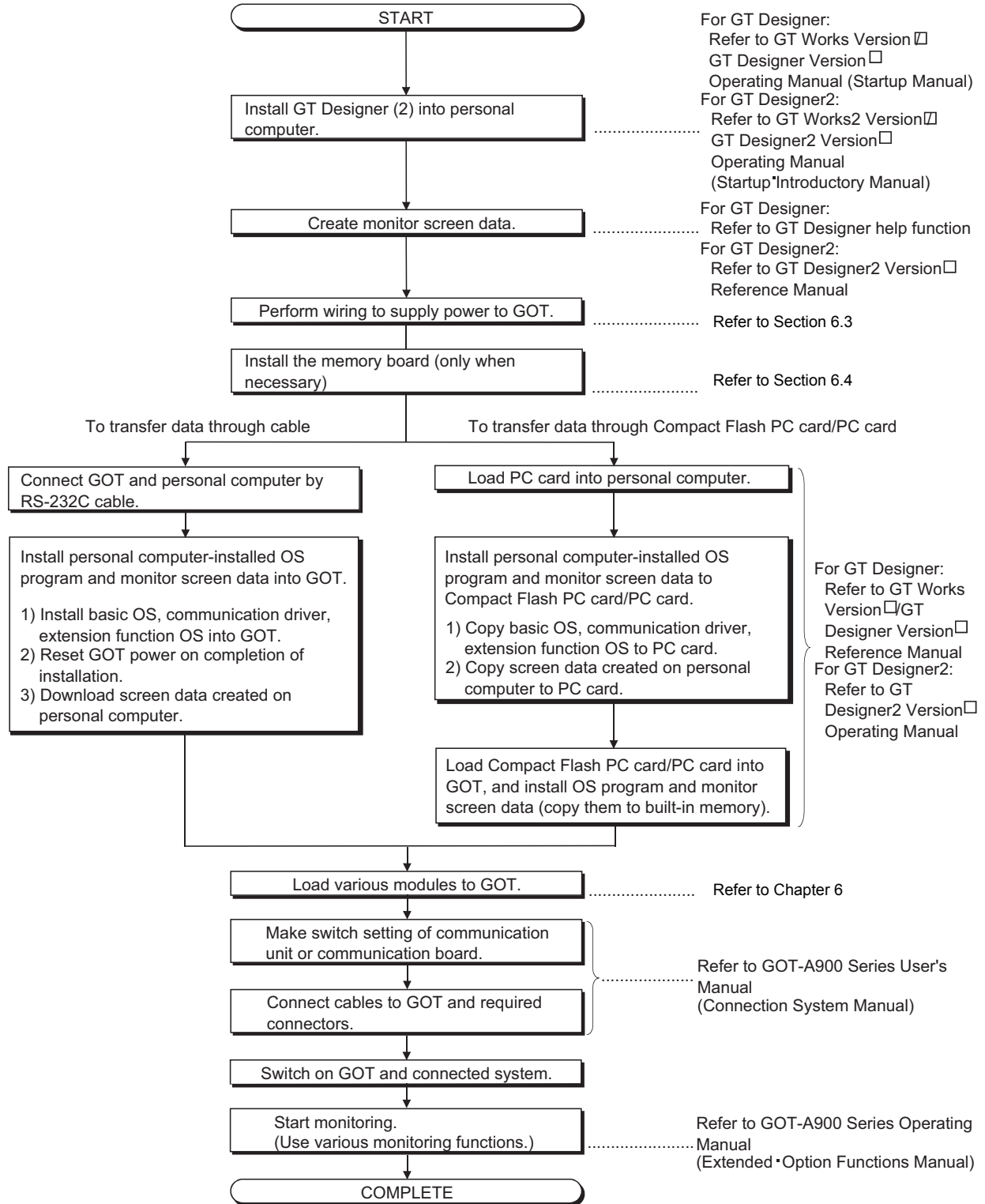

1	OVERVIEW
2	SYSTEM CONFIGURATION
3	PERFORMANCE
4	NAMES OF THE PARTS AND THEIR SETTINGS
5	ROUGH PRE-OPERATION PROCEDURE
6	HANDLING
7	MAINTENANCE AND INSPECTION
8	EMC DIRECTIVE



# 6 HANDLING

This chapter explains how to handle the GOT main unit and components.

## 6.1 GOT Main Unit

### 6.1.1 Handling instructions

This section describes the instructions for handling the GOT main unit and components.

#### DANGER

- Before installing or removing the GOT main unit to or from an enclosure, always turn the GOT power OFF before installing or removing the GOT main unit to or from an enclosure.  
Not doing so can cause a module failure or malfunction.
- Before loading or unloading the communication module, communication board, external I/O interface module or memory card interface module to or from the GOT, always turn the GOT power OFF before loading or unloading the communication module, external I/O interface module or memory card interface module to or from the GOT.  
Not doing so can cause a module failure or malfunction.
- Before starting wiring, always turn the GOT power OFF before starting wiring.  
Not doing so may cause an electric shock, product damage or malfunction.

#### CAUTION

- The GOT should be used in the environment given in the general specifications of this user's manual.  
Not doing so can cause an electric shock, fire, malfunction or product damage or deterioration.
- When mounting the GOT main unit to an enclosure, tighten the mounting screws in the specified torque range.  
Undertightening can cause a drop, short circuit or malfunction.  
Overtightening can cause a drop, short circuit or malfunction due to the damage of the screws or module.
- When loading the communication module to the GOT main unit, fit it to the connection interface of the GOT and tighten the mounting screws in the specified torque range.  
Undertightening can cause a drop, failure or malfunction.  
Overtightening can cause a drop, failure or malfunction due to the damage of the screws or module.
- Please make sure to ground FG terminal of the GOT power supply unit by applying Class D Grounding (Class 3 Grounding) Method or higher which is used exclusively for the GOT.
- Correctly wire the power supply module on the GOT after confirming the rated voltage and terminal arrangement of the product.  
Not doing so can cause a fire or failure.
- Exercise care to avoid foreign matter such as chips and wire offcuts entering the module.  
Not doing so can cause a fire, failure or malfunction.



## CAUTION

- Tighten the terminal screws of the GOT power supply section in the specified torque range.  
Undertightening can cause a short circuit or malfunction.  
Overtightening can cause a short circuit or malfunction due to the damage of the screws or module.
- Plug the bus connection cable by inserting it into the connector of the connected module until it "clicks".  
After plugging, check that it has been inserted snugly.  
Not doing so can cause a malfunction due to a contact fault.
- Plug the communication cable into the connector of the connected module and tighten the mounting and terminal screws in the specified torque range.  
Undertightening can cause a short circuit or malfunction.  
Overtightening can cause a short circuit or malfunction due to the damage of the screws or module.
- Do not touch the conductive and electronic parts of the module directly.  
Doing so can cause a module malfunction or failure.

- (1) Do not drop the module or give it strong impact.  
Doing so can cause a failure because the display device is made of glass.
- (2) Do not remove the printed circuit board of the module from the case.  
Doing so can cause a failure.
- (3) When mounting the main unit to a control box or the like, set the display section as shown below.
  - When the temperature inside the enclosure is 40 to 55°C or less, the mounting angle should be in the range 60 to 105 degrees.

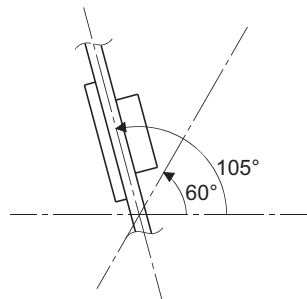
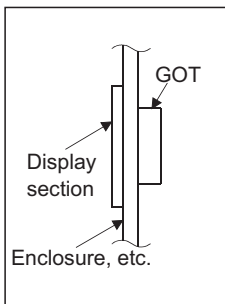

- The GOT will be deteriorated earlier if it is used at the mounting angle other than the above.  
Therefore, the temperature inside the enclosure should be within 40 °C .

- (4) Tighten the screws in the following specified range.

Screw Location	Tightening Torque Range
Ground terminal screw (M3 screw)	59 to 88N · cm
Terminal block terminal screw (M3 screw)	
Module mounting screw (M4 screw)	36 to 48N · cm
Communication board mounting screw (M3 screw)	
Communication module mounting screw (M3 screw)	
Option module mounting screw (M3 screw)	
Case fixing screw (M3 screw)	25 to 35N · cm
Memory board mounting screw (M2.6 screw)	
RS-232C connector mounting screw (#4-40 UNC (inch screw))	20 to 28N · cm
Bus connection cable connector mounting screw for QCPU (Q mode)	20N · cm

## 6.1.2 Installation method

This section provides how to install the GOT.

### (1) Mounting panel cutting dimensions

When mounting the GOT on a control box door, user-made mounting base or the like, the door or mounting base must be cut as indicated below.

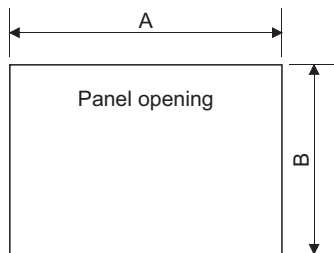

Type	A [mm](inch)	B [mm](inch)
A95*GOT	156 (6.14) [+1.0 (0.04), -0(0)]	123.5 (4.86) [+1.0 (0.04), -0(0)]
A956WGOT	205.5 (8.09) [+1.0 (0.04), -0(0)]	123.5 (4.86) [+1.0 (0.04), -0(0)]

### (2) Mounting position

When mounting the GOT, the following clearances must be left from the other device.

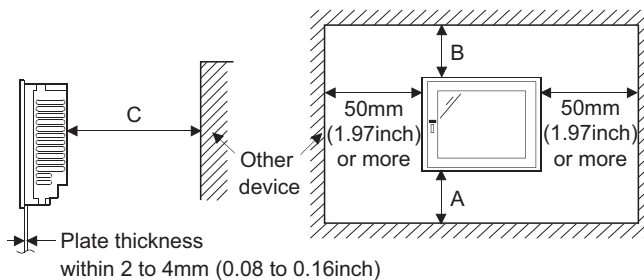

Part A size: Because the connection cable of the GOT is pulled downward, the following space is required according to its radius of curvature.

Item	A [mm (inch)]
A95GOT	130 (5.12) or more
A956WGOT	

Part B size: Please allow a gap 80mm (3.15inch) or more from the structure and other equipment in the upper part of the unit to often allow good ventilation.

Part C size: When installing devices that generate radiated noise (such as a contactor) or a device that generate heat near the GOT, always leave a clearance of 100mm (3.94inch) or more to the back and 50mm (1.97inch) or more to the left and right to avoid the effects of the noise and heat.



Depending on the type of the cable to be connected to the GOT main body, longer clearances than those specified above may be required.

When mounting a GOT, be sure to consider the dimensions of the connector and the cable bend radius.

(3) Mounting method

- (a) Put the GOT main unit into the panel opening, with its front face first.
- (b) Mount the GOT in the following four locations at its top and bottom.

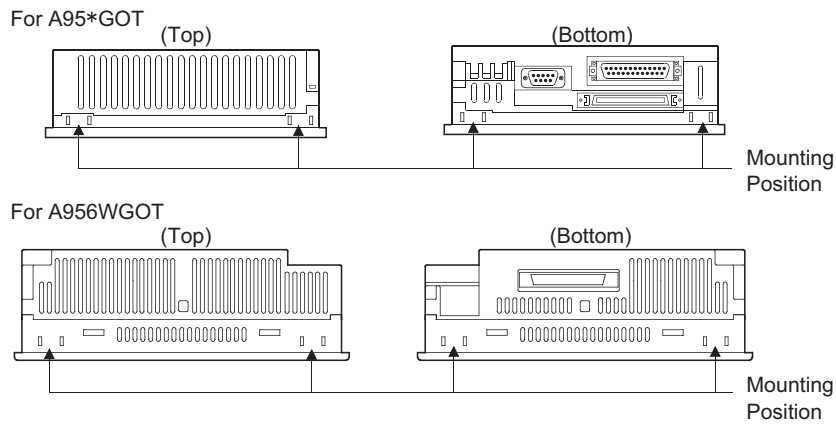

- (c) How to mount and fix the mounting fixture is given below.

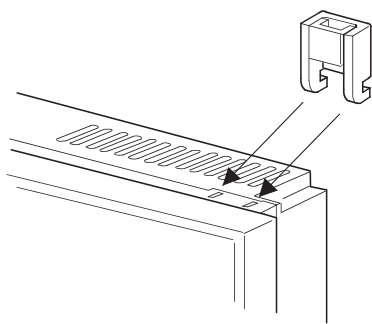

- 1) Insert the mounting fixture into the fixture fitting portion of the GOT main unit.
- 2) Tighten and fix the mounting screw in the specified torque range.



## 6.1.3 Wiring method

### DANGER

- Completely turn off the externally supplied power used in the system when installing or placing wiring. Not completely turning off all power could result in electric shock, damage to the product.

### CAUTION

- Be sure to ground the FG terminal and LG terminal of the GOT power supply section to the protective ground conductor. Not doing so could result in electric shock or erroneous operation.
- When wiring in the GOT power section, be sure that it is done correctly by checking the product's rated voltage and the terminal layout. Connecting a power supply that is different from the rating or incorrectly wiring the product could result in fire or erroneous operation.
- Tighten the terminal screws of the GOT power supply section within the specified torque range.  
If the terminal screws are loose, it could result in short circuits, erroneous operation or erroneous operation.  
Tightening the terminal screws too far may cause damages to the screws and/or the module, resulting in fallout, short circuits, or erroneous operation.
- Be sure there are no foreign substances such as sawdust or wiring debris inside the GOT main unit.

### Remark

#### General view of noise countermeasures

There are two types of noise: radiated noise, which is transmitted through the air, and conducted noise, which is transmitted through a connection wire. In noise countermeasures, the both two types of noise should be taken into account. As the noise countermeasures, there are the following three methods.

- (1) Block noise
  - (a) Keep signal wires away from a possible noise source as power wires or high-power driving circuits.
  - (b) Shield signal wires.
- (2) Reduce generated noise
  - (a) Reduce the noise generated from high-power motor drive circuits.
- (3) Ground noise without fail
  - (a) Earth the grounding wire to the ground without fail.
  - (b) Use a grounding wire as thick and short as possible to ensure low grounding impedance.
  - (c) Separate the grounding between power and control systems.

1) Power supply wiring

- Separate the GOT's power supply line from the lines for I/O devices and power devices as shown below.

When there is much noise, connect an insulation transformer.

Power supply wiring diagram

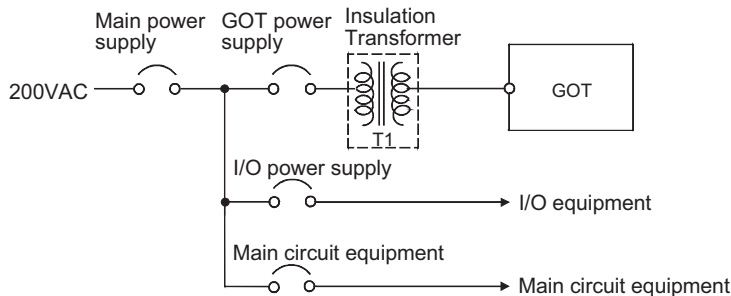

- 100VAC, 200VAC and 24VDC wires should be twisted as dense as possible.

Connect the modules with the shortest distance.

Also, to reduce the voltage drop to the minimum, use the thickest wires possible (0.75 to 2mm<sup>2</sup>). Use a solderless terminal for M3 screw. Also, be sure to tighten the M3 screw within tightening torque 0.55 to 0.88 N·m in order not to cause trouble.

- Do not bundle the 100VAC, 200VAC and 24VDC wires with, or run them close to, the main circuit (high voltage, large current) and I/O signal lines. Reserve a distance of at least 100 mm from adjacent wires.
- As a countermeasure to power surge due to lightning, connect a surge absorber for lightning as shown below.

Lightening surge absorber connection diagram

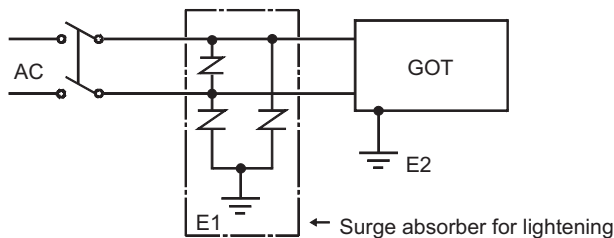

**Point**

- (1) Separate the ground of the surge absorber for lightning (E1) from that of the GOT (E2).
- (2) Select a surge absorber for lightning whose power supply voltage does not exceed the maximum allowable circuit voltage even at the time of maximum power supply voltage elevation.

## 2) Connection Cable Wiring

- Do not bind connection cables with the main circuit (high voltage, heavy current) or I/O signal cables, or lay them close to each other.
- When using A8GT-C□EXSS-1 or A8GT-C□BS, ground wires as below.

### (1) When using A8GT-C□EXSS-1 cable

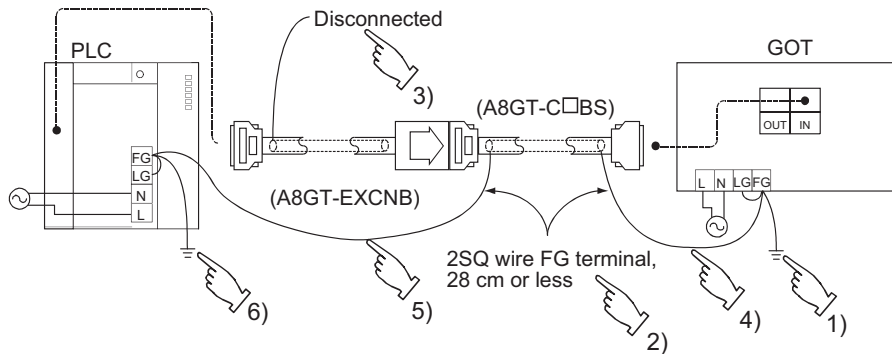

- 1) Connect the LG and FG terminals of GOT unit power to the ground through the terminal block with one wire.
- 2) Use FG wires of 28 cm or less for the A8GT-C□BS cable.
- 3) Do not connect the FG grounding wire of A8GT-EXCNCB cable.
- 4) Connect the A8GT-C□BS cable's FG wire to FG of the GOT unit power terminal block.
- 5) Connect the A8GT-C□BS cable's FG wire on the PLC side to FG of the PLC power supply module.
- 6) Connect the LG and FG terminals of the terminal block on the PLC to ground with one wire.

### (2) When using A8GT-C□BS cable

Connect the A8GT-C□BS cable's FG wires on the both sides to the FG terminals on the power terminal block of the both side GOTs.

### 3) Grounding

- For grounding, perform the following:

Use a dedicated grounding wire as far as possible. (Grounding resistance of 100 Ω or less.)

- When a dedicated grounding cannot be performed, use (2) Common Grounding shown below. Also, be sure to take noise countermeasures other than grounding.

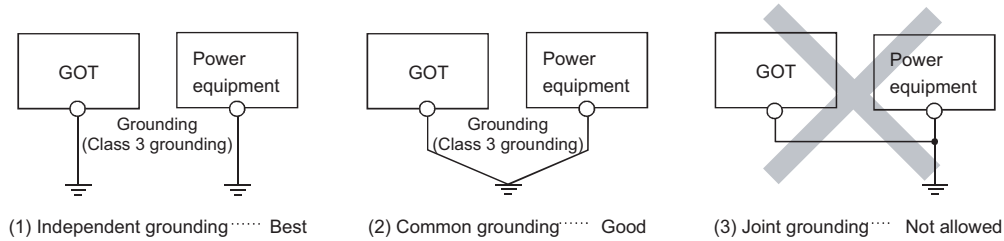

- For grounding a cable, use the cable of 2 mm<sup>2</sup> or more.

Position the ground-contact point as closely to the sequencer as possible, and reduce the length of the grounding cable as much as possible.

#### (a) An example of independent grounding

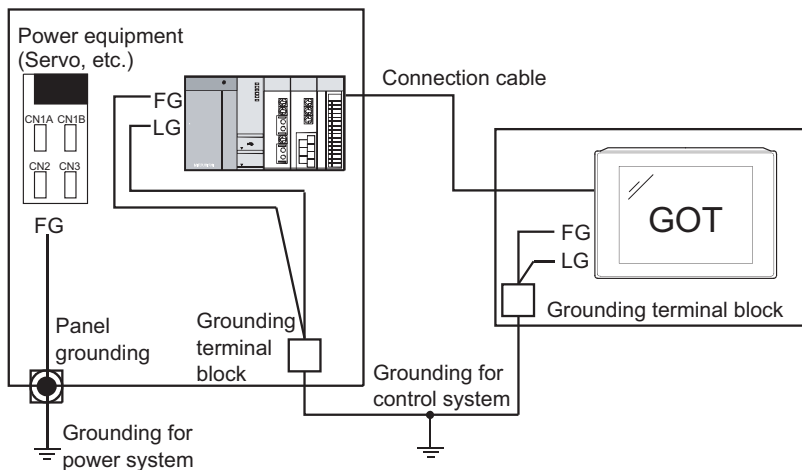

- \* For control system grounding, apply single-point grounding for one system.

Especially for the devices communicating each other, be sure to earth the grounding wire at one point.

#### (b) An example of common grounding

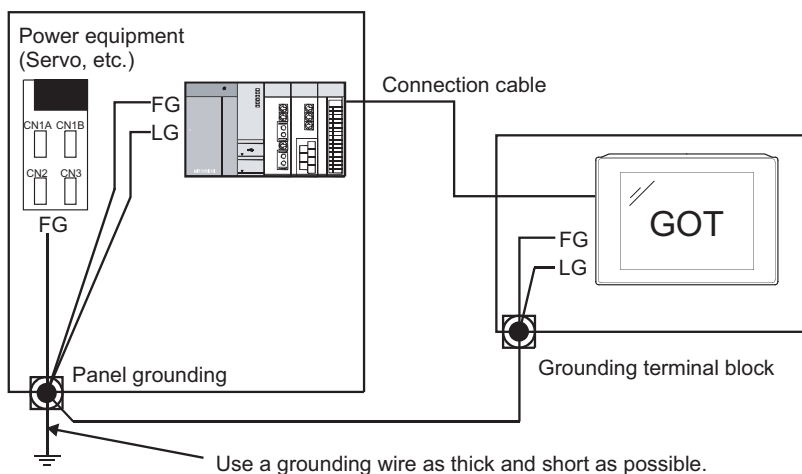

- \* Apply single-point grounding for one system.

(c) Recommended terminal shapes

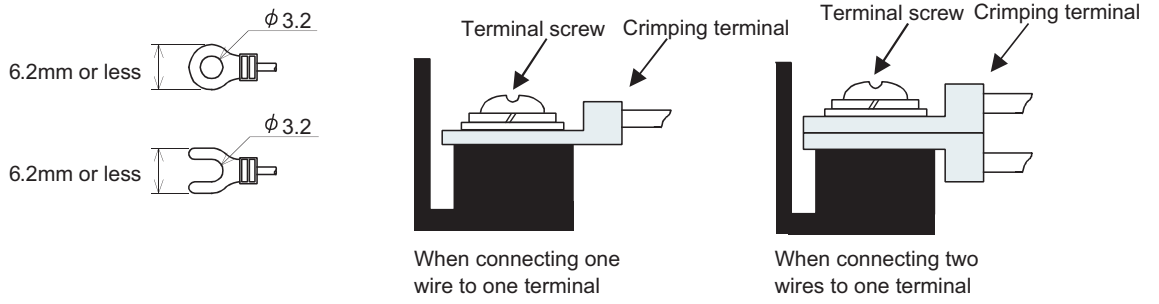

Applicable crimping terminal	RAV1.25-3, V2-S3.3, V2-N3A, FV2-N3A
------------------------------	-------------------------------------

1	OVERVIEW
2	SYSTEM CONFIGURATION
3	PERFORMANCE
4	NAMES OF THE PARTS AND THEIR SETTINGS
5	ROUGH PRE-OPERATION PROCEDURE
6	HANDLING
7	MAINTENANCE AND INSPECTION
8	EMC DIRECTIVE

#### 4) Connecting to the GOT Power Section

The following diagram shows the wiring example of power lines, grounding lines, etc. to the GOT power section.

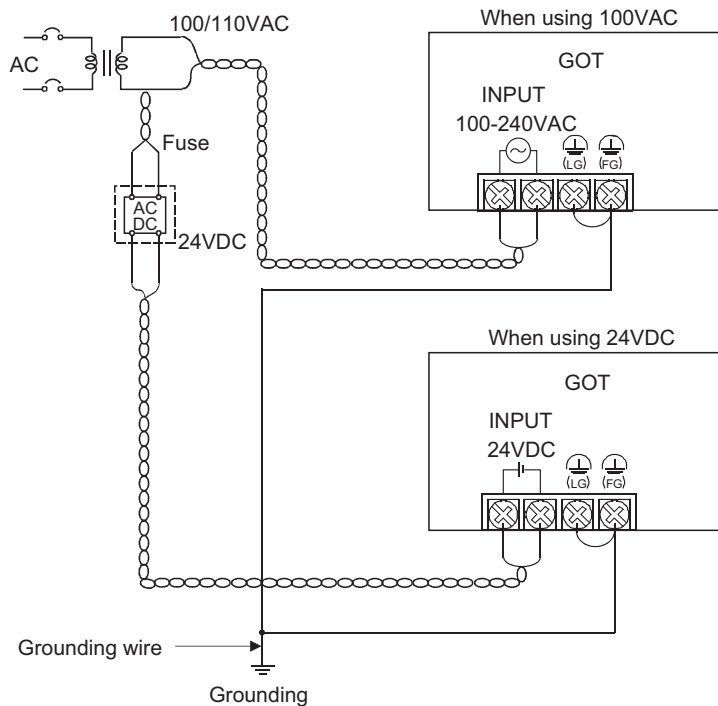

### Point

- (1) Use the thickest possible (max. 2 mm<sup>2</sup> (14 AWG)) wires for the 100/200 VAC and 24 VDC power cables. Be sure to twist these wires starting at the connection terminals. To prevent a short-circuit should any screws loosen, use solderless terminals with insulation sleeves.
- (2) When the LG terminals and FG terminals are connected, be sure to ground the wires. Do not connect the LG terminals and FG terminals to anything other than ground. If LG terminals and FG terminals are connected without grounding the wires, the PLC may be susceptible to noise. In addition, since the LG terminals have potential, the operator may receive an electric shock when touching metal parts.

How to wiring the GOT power supply section is explained below.

Wiring diagram of the A95\*GOT

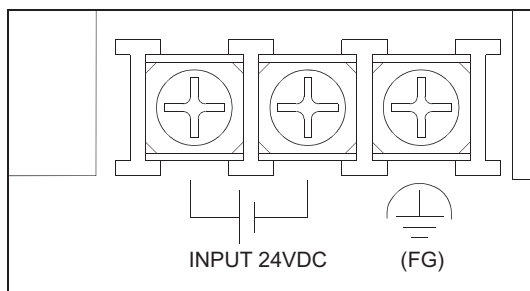

Wiring diagram of the A956WGOT

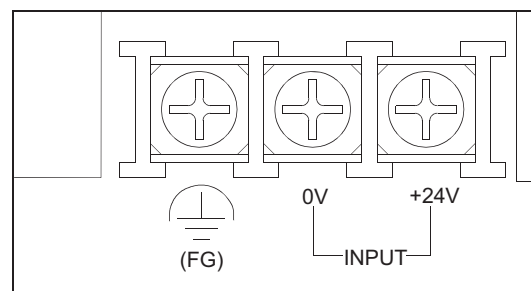

### Point

Note that the terminals of the A956WGOT are arranged in the reverse order of the terminals of the A95\*GOT.

## 6.1.4 Installation of handy type GOT

The A950GOT can be used as a handy type, in addition to the conventional installation method.

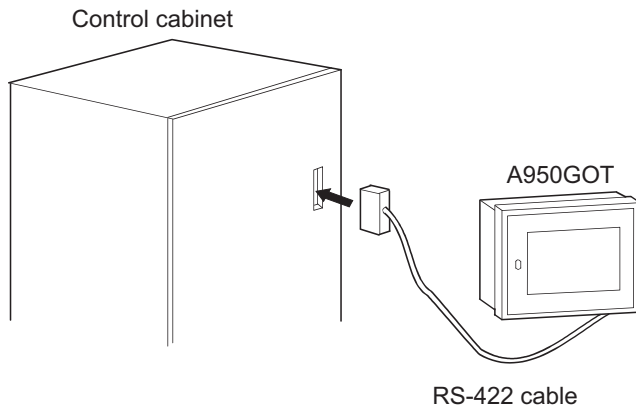

RS-422 cable to connect the GOT and the computer link unit must be prepared by the user.

### 1) Wiring diagram

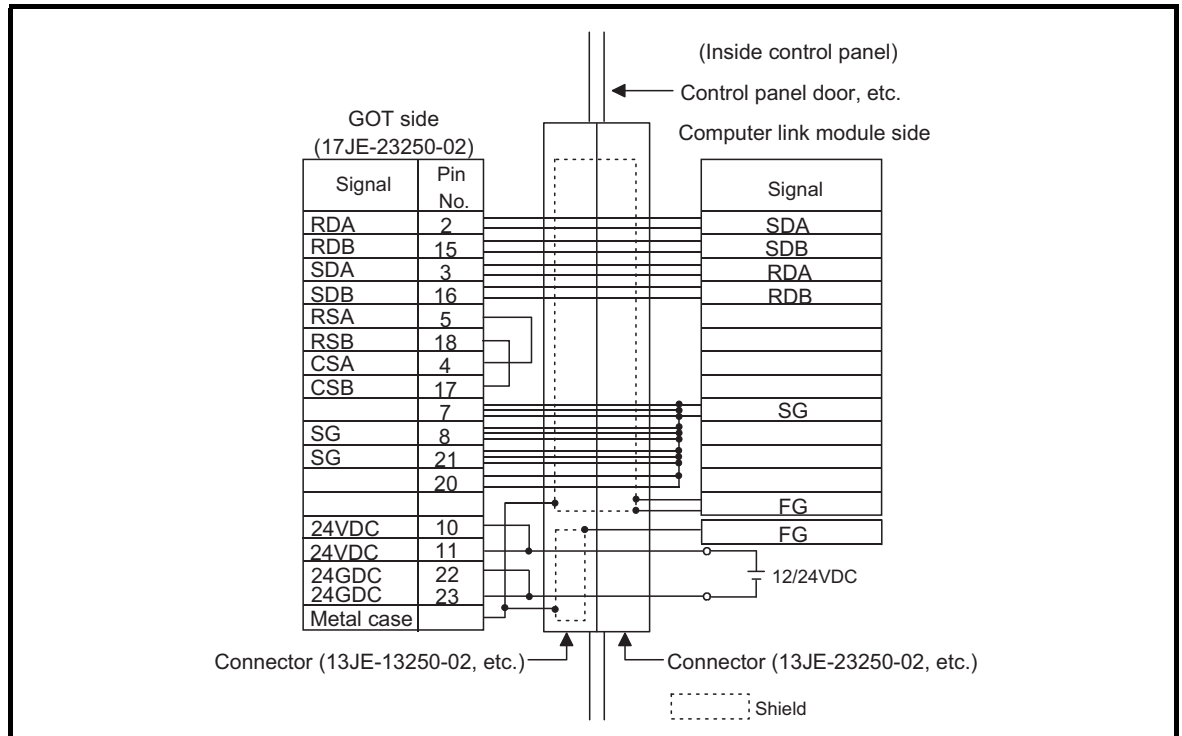

2) An internal diagram of the control panel is shown below.

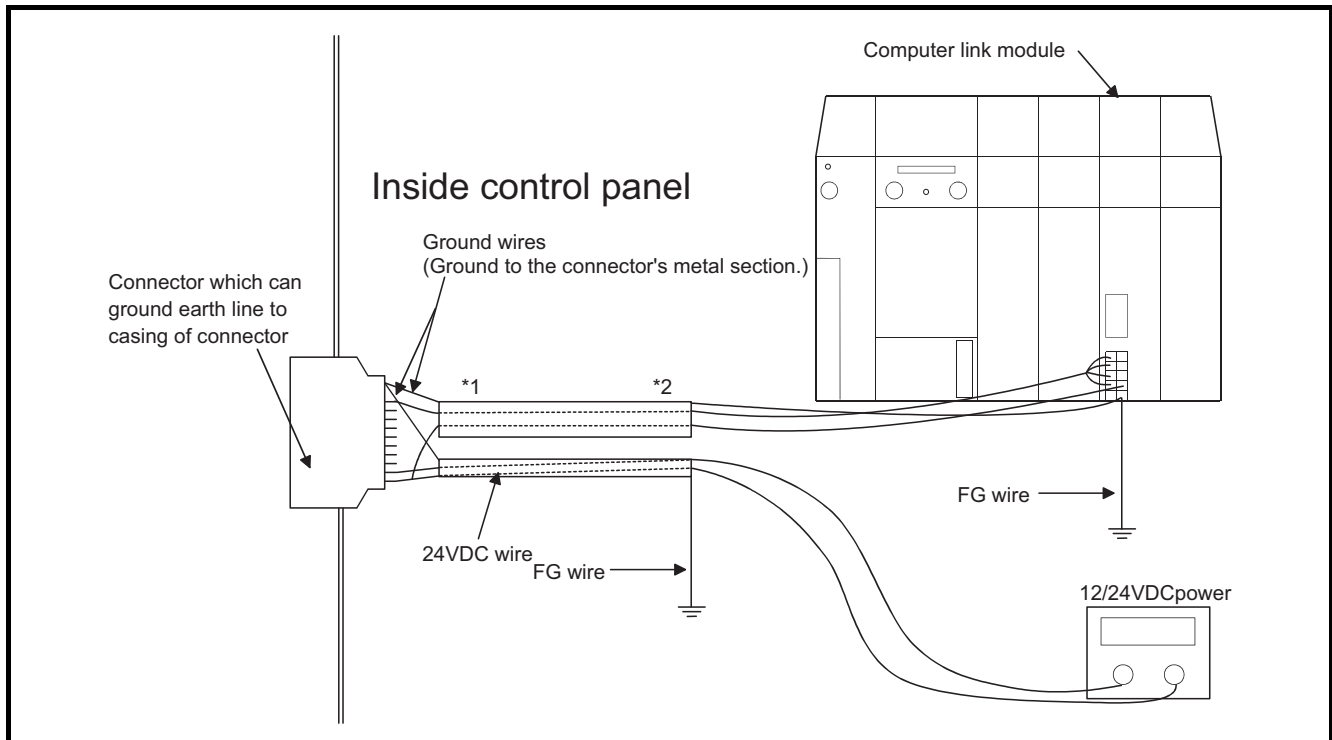

\*1: Separately ground the power wire and signal wire.

\*2: Power wire and the signal wire must be separated by a separate shield and ground to FG.

3) Notes when cable is made.

- The cable must be 200m or shorter.
- When branching inside and outside the control panel, use a connector in between.  
The connector used must be able to attach the earthing to the connector casing.
- When the cable is made, the terminal 24VDC of the connector on the GOT side is connected with the 24VDC power supply of the control board.  
Therefore, it should not be connected to the power supply terminal in the back of the main body of GOT.



## 6.2 Protective Sheet

The protective sheet is used to protect the operation surface from scratches and contamination which may take place when the touch keys of the GOT display section are operated.

### 6.2.1 Protective sheet type

The following protective sheet type is available.

Type	Description
A9GT-50PSC	Transparent protective sheet for A95*GOT
A9GT-50WPSC	Transparent protective sheet for A956WGOT

### 6.2.2 Mounting procedure

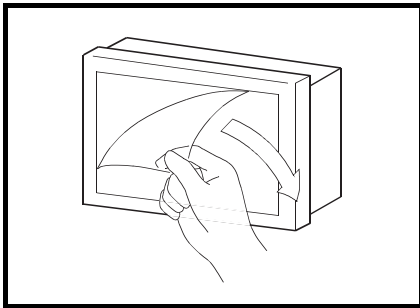

- 1) From the display section of the GOT, peel off the sheet applied before shipment from the factory or the old protective sheet.

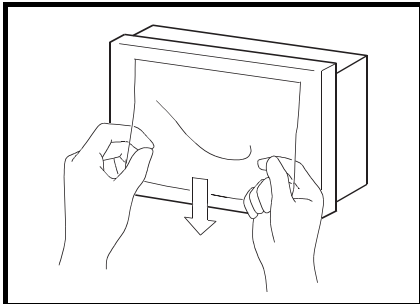

- 2) Peel off the release film of the new protective sheet and apply its adhesive surface to the display section of the GOT. When applying the protective sheet, exercise care not to make it loose and not to make gaps on the adhesive surface.

## 6.3 Memory board (A956WGOT only)

The memory board is used to store the optional function OS program (ladder monitoring function, recipe function, speech output function, etc.) and to increase the built-in memory capacity.

### 6.3.1 Memory board types

The following memory board types are available.

Type	Description
A9GT-FNB	Exclusively used for optional function OS storage
A9GT-FNB1M	For optional function OS storage + built-in memory extension, 1M byte
A9GT-FNB2M	For optional function OS storage + built-in memory extension, 2M byte
A9GT-FNB4M	For optional function OS storage + built-in memory extension, 4M byte
A9GT-FNB8M	For optional function OS storage + built-in memory extension, 8M byte
A9GT-QFNB	Exclusively used for optional function OS storage (MELSEC-Q Ladder monitor compatible)
A9GT-QFNB4M	For optional function OS storage + built-in memory extension, 4M byte (MELSEC-Q Ladder monitor compatible)
A9GT-QFNB8M	For optional function OS storage + built-in memory extension, 8M byte (MELSEC-Q Ladder monitor compatible)

\*1 When using the ladder monitor function, use the A9GT-QFNB (4/8M).

\*2 There are restrictions on the ROM\_BIOS version of the GOT depending on the hardware version of the memory board. However, the A956WGOT has no problems since it is installed with supported ROM\_BIOS, starting with the initial product.

### 6.3.2 Mounting procedure

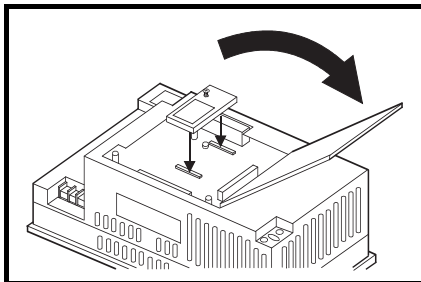

- 1) Open the slot cover on the back of the A956WGOT
- 2) Mount the memory board in the slot for mounting a memory board. Be careful not to touch the board inside the GOT main body by hand when mounting the memory board.

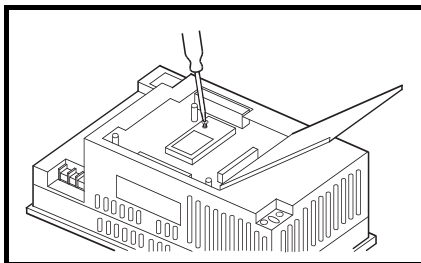

- 3) Fix by tightening the mounting screws of the memory board within the specified torque range.

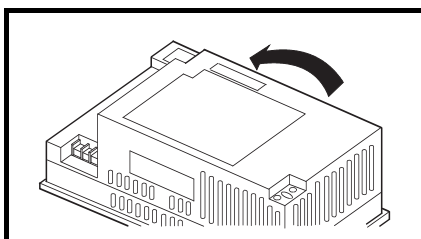

- 4) Close the slot cover.

## 6.4 Memory Card Interface Module

The memory card interface module is connected to the GOT when the PC card is used with the GOT. The PC card is used to transfer the OS or monitor screen data or to store data using the alarm history function, recipe function or other object function.

Refer to the following manual for details of OS or monitor screen data transfer.

- When GT Designer is used : GT Works Version □ /GT Designer Version □ Reference Manual
- When GT Designer2 is used : GT Designer2 Version □ Operating Manual

Refer to the following manual for details of the alarm history function and recipe function.

- When GT Designer is used : Help function of GT Designer
- When GT Designer2 is used : GT Designer2 Version □ Reference Manual

### 6.4.1 Memory card interface module type

The following memory card interface module type is available.

Type	Description
A1SD59J-MIF	Memory card interface module type

### 6.4.2 Mounting procedure

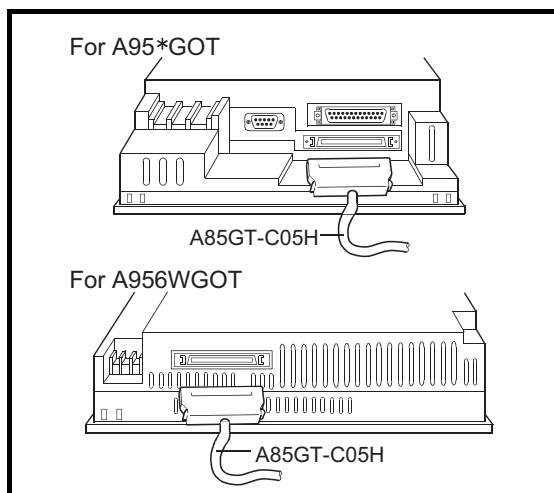

- 1) Install the A1SD59J-MIF to the control cabinet, etc.
- 2) Plug the GOT side connector to the option unit at the bottom of the GOT.

- For details of the A1SD59-MIF specifications, refer to the A1SD59J-MIF Memory Card Interface Module User's Manual (Hardware).
- When a memory card interface unit is used, a compact flash PC card cannot be used. When using a memory card interface module, turn off the memory card access switch on the A956WGOT main body.

### 6.4.3 PC card types

---

The PC card usable is any of the PC card having the following specifications (standard) whose operations have been checked by Mitsubishi.

- Commercial SRAM type PC card conforming to PCMCIA ver. 2.1

### 6.4.4 Battery changing timing and method

---

(1) How to check for battery low

The GOT checks for a battery low of the memory card loaded. (Only when the memory card access switch is ON)

The battery low checking methods are given below.

1) Using the self-diagnostic function to check

When a battery low occurs, the corresponding message appears on the self-diagnostic screen.

For the details, refer to the [GOT-A900 Series Operating Manual

(Extended - Option Functions Manual)].

2) Using the alarm list display (system alarm) function to check

When a battery low occurs, the error warning message and battery low error code appear on the monitor screen.

Refer to the following manual for details.

- When GT Designer is used: Help function of GT Designer
- When GT Designer2 is used: GT Designer2 Version  Reference Manual

(2) Battery life

For the PC card backup time, refer to the instruction manual attached to the memory card used.

(3) Battery changing

For the PC card battery changing method, refer to the instruction manual attached to the memory card used.

## 6.4.5 Loading and unloading procedures

The PC card can be loaded/unloaded while power is on. Note that the PC card should be loaded/unloaded after it has been made ready to be loaded/unloaded in the following procedures.

### (1) Mounting

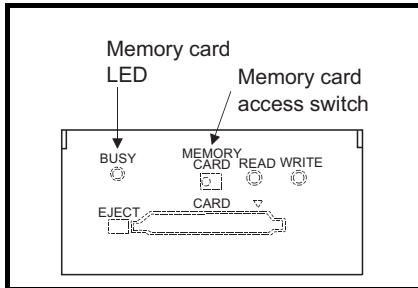

- 1) Set the memory card access switch of the A1SD59J-MIF to "OFF" and make sure that the memory card LED goes off. When the memory card LED goes off, the PC card can be loaded/unloaded while power is on.

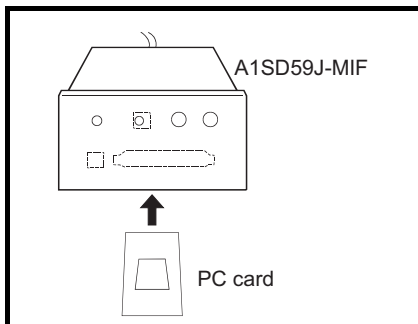

- 2) When loading the PC card into the A1SD59J-MIF, insert and load it into the PC card interface with its top face up.

### (2) Dismounting

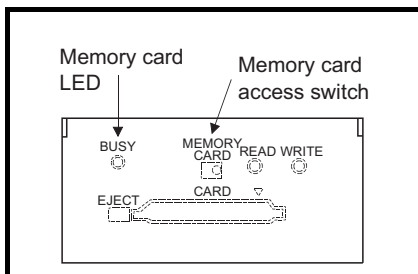

- 1) Set the memory card access switch of the A1SD59J-MIF to "OFF" and make sure that the memory card LED goes off. When the PC card LED goes off, the memory card can be loaded/unloaded while power is on.

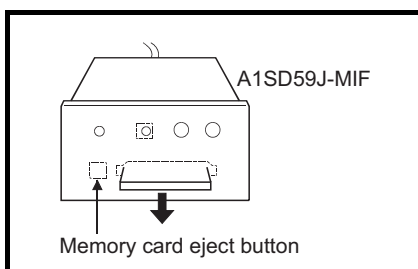

- 2) Remove the PC card after fully pushing the memory card eject button of the A1SD59J-MIF to eject the PC card.

## 6.5 Compact flash PC card (A956WGOT only)

---

The Compact flash PC card is used to transfer the OS and monitor screen data and to store the data of the alarm history and recipe functions.

Refer to the following manual for details of OS or monitor screen data transfer.

- When GT Designer is used : GT Works Version □ /GT Designer Version □ Reference Manual
- When GT Designer2 is used : GT Designer2 Version □ Operating Manual

Refer to the following manual for details of the alarm history function and recipe function.

- When GT Designer is used : Help function of GT Designer
- When GT Designer2 is used : GT Designer2 Version □ Reference Manual

### 6.5.1 Compact flash PC card types

---

The Compact flash PC card usable is any of the Compact flash PC card having the following specifications (standard) whose operations have been checked by Mitsubishi.

- Commercial Compact flash PC card conforming to Compact flash™.

For the operation-confirmed models, refer to the separately available document "List of operation-confirmed devices for GOT900 series" (Technical bulletin T10-0028).

When the document is necessary, please contact your local Mitsubishi representative.

If the model used is not given in the document, it may not operate properly.

The above document can be viewed on the Mitsubishi Electric FA Network Service On World Wide, MELFANSweb home page.

(MELFANSweb home page: <http://wwwf2.MitsubishiElectric.co.jp/melfansweb/english/>)

## 6.5.2 Loading and unloading procedures

The Compact flash PC card can be loaded/unloaded while power is on. Note that the Compact flash PC card should be loaded/unloaded after it has been made ready to be loaded/unloaded in the following procedures.

### (1) Mounting

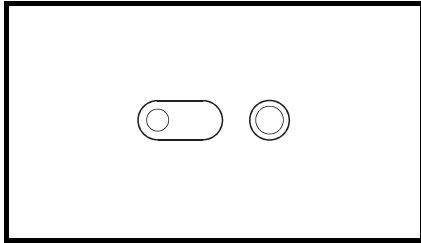

- 1) Set the compact flash card access switch of the GOT to "OFF" and make sure that the compact flash PC card LED goes off. When the compact flash PC card LED goes off, the compact flash PC card can be loaded/unloaded while power is on.

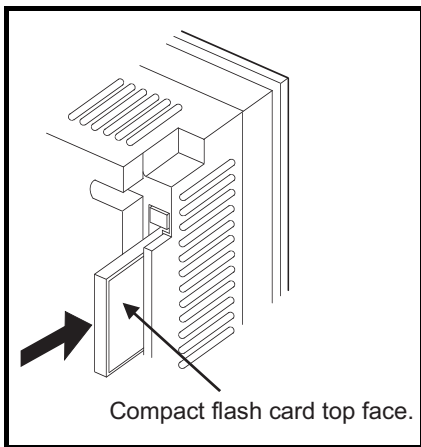

- 2) When loading the compact flash PC card into the GOT, insert and load it into the compact flash PC card interface with its top face up.

### (2) Dismounting

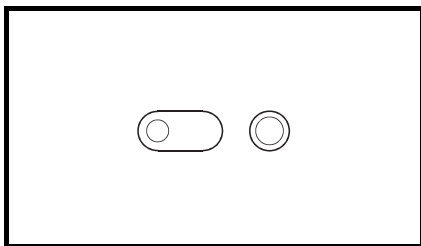

- 1) Set the compact flash PC card access switch of the GOT to "OFF" and make sure that the compact flash PC card LED goes off. When the compact flash PC card LED goes off, the compact flash PC card can be loaded/unloaded while power is on.

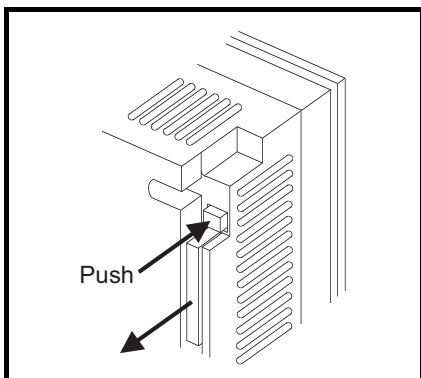

- 2) Remove the compact flash PC card after fully pushing the compact flash PC card ejection button of the GOT to eject the compact flash PC card.

- When a memory card interface unit is used, a compact flash PC card cannot be used. When using a memory card interface module, turn off the memory card access switch on the GOT main body.

## 6.6 Communication Board (A956WGOT only)

The communication board is used to make the A956WGOT interface compatible with the system to be connected to.

For the details of the connection form, refer to the [GOT-A900 Series User's Manual (Connection System Manual)].

### 6.6.1 Communication board types

The following connection board types are available.

Type	Description
A9GT-50WQBUISS	For bus connection, small connector type (For QCPU (Q mode))
A9GT-50WBUISS	For bus connection, small connector type (For A/QnA/Motion controller CPU)
A9GT-50WRS4	For Direct connection to CPU/Computer link connection/Microcomputer connection and RS-422 connection
A9GT-50WRS2	For Direct connection to CPU/Computer link connection/Microcomputer connection and RS-232C connection

### 6.6.2 Mounting procedure

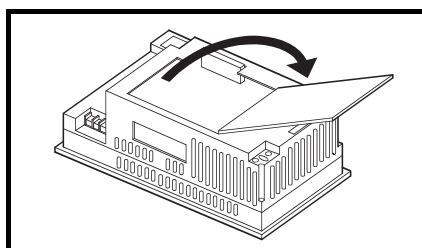

1) Open the slot cover on the back of the A956WGOT.

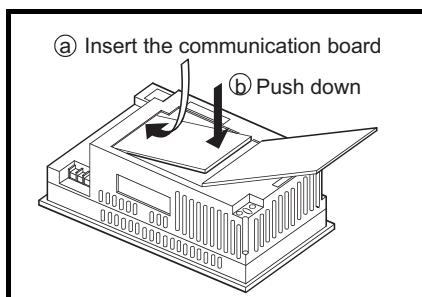

2) Mount the communication board in the slot for mounting a communication board.  
(Align the hole for the attachment screw on the transmission board with the hole for the attachment screw on the transmission board of the GOT main module, then attach.)

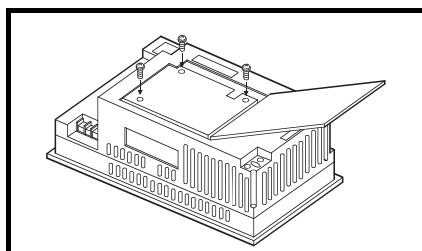

3) Fix by tightening the mounting screws of the communication board within the specified torque range.

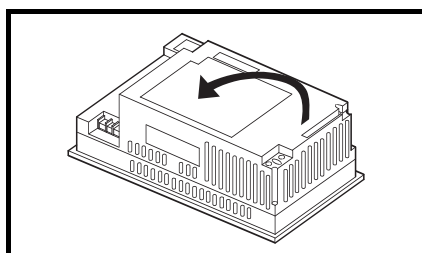

4) Close the slot cover.



## 6.7 Communication Module (A956GOT, A956WGOT Only)

The communication module is used to make the A956GOT, A956WGOT interface compatible with the system to be connected to.

For the details of the connection form, refer to the [GOT-A900 Series User's Manual (Connection System Manual)].

### 6.7.1 Connection module types

The following connection module types are available.

Type	Description
A9GT-QBUS2SU	For multidrop bus connection, small connector type (For QCPU (Q mode))
A9GT-BUSSU	For bus connection, small connector type (For A/QnA/Motion controller CPU)
A7GT-BUSS *1 *2	
A9GT-BUS2SU	For multidrop bus connection, small connector type (For A/QnA/Motion controller CPU)
A7GT-BUS2S *1 *2	
A7GT-J71AP23	For MELSECNET(II) optical link connection, for use as local station
A7GT-J71AR23	For MELSECNET(II) coaxial link connection, for use as local station
A7GT-J71AT23B	For MELSECNET/B connection, for use as local station
A9GT-QJ71LP23	For MELSECNET/10 optical loop network connection, for use as ordinary station *3
A9GT-QJ71BR13	For MELSECNET/10 coaxial bus network connection, for use as ordinary station *3
A7GT-J71LP23	For MELSECNET/10 optical loop network connection, for use as ordinary station *3
A7GT-J71BR13	For MELSECNET/10 coaxial bus network connection, for use as ordinary station *3
A8GT-J61BT13	For CC-Link connection, for use as intelligent device station
A8GT-J61BT15	For CC-Link connection, for use as remote device station
A9GT-J71E71-T	For Ethernet connection

\*1 The A956WGOT cannot be used.

\*2 When using the A7GT-BUSS or A7GT-BUS2S, the module hardware version must be version B or above.



Confirm the hardware version of the unit stamped on the rating plate of the product.

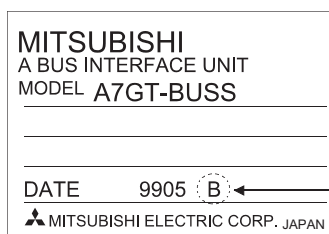

Rating plate

\*3 For the A9GT-QJ71LP23 and A9GT-QJ71BR13, the device range (QCPU, QnACPU, ACPU) that can be monitored changes depending on the communication driver.

When the A7GT-J71LP23 or A7GT-J71BR13 is mounted, only the device range of the AnA can be monitored.

For details, refer to the GOT-A900 Series User's Manual (Connection).

## 6.7.2 Mounting procedure

---

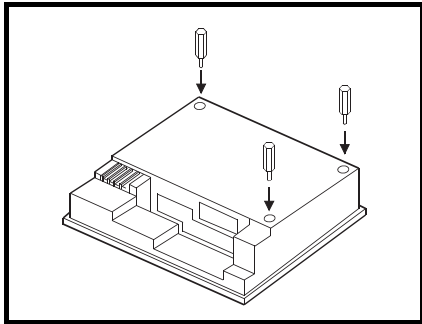

1) Fit the communication module securing fixtures in the GOT main unit.

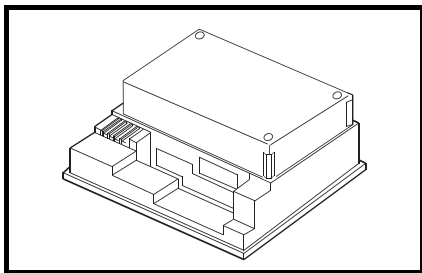

2) Mount the communication module on the GOT interface.

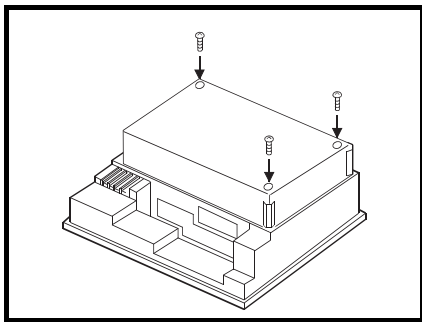

3) Tighten and fix the mounting screws (3 pcs.) of the communication module in the specified torque range.

The following software packages are required to use the communication module.

Model name	Compatible software packages	
	GT Works 2 GT Designer 2	GT Works GT Designer
A9GT-QBUS2SU	SW1D5C-GTWK2-E Version A or later SW1D5C-GTD2-E Version A or later	SW0D5C-GTWORKS-E Version A or later SW3D5C-GOTRE-PACK Version A or later
A7GT-BUSS		
A9GT-BUSSU		
A7GT-BUS2S		
A9GT-BUS2SU	SW1D5C-GTWK2-E Version A or later SW1D5C-GTD2-E Version A or later	SW0D5C-GTWORKS-E Version A or later *1 SW3D5C-GOTRE-PACK Version A or later *1
A7GT-J71AP23		
A7GT-J71AR23		
A7GT-J71AT23B		
A7GT-J71LP23		
A7GT-J71BR13	SW1D5C-GTWK2-E Version A or later *1 SW1D5C-GTD2-E Version A or later *1	SW0D5C-GTWORKS-E Version A or later *1 SW3D5C-GOTRE-PACK Version A or later *1
A9GT-QJ71LP23		
A9GT-QJ71BR13	SW1D5C-GTWK2-E Version K or later *2 SW1D5C-GTD2-E Version K or later *2	SW5D5C-GTWORKS-E Version P or later *3 SW5D5C-GOTRE-PACK Version P or later *3
A8GT-J61BT13	SW1D5C-GTWK2-E Version A or later SW1D5C-GTD2-E Version A or later	
A8GT-J61BT15		
A9GT-J71E71-T		

\*1 The device range of the AnA can be monitored.

\*2 The device ranges of the QCPU, QnACPU and ACPU can be monitored.

\*3 When using the A9GT-J71E71-T whose hardware version is Version E or later, use Version 26C or later. (Cannot be used for Version P to Version Y.)

1	OVERVIEW
2	SYSTEM CONFIGURATION
3	PERFORMANCE
4	NAMES OF THE PARTS AND THEIR SETTINGS
5	ROUGH PRE-OPERATION PROCEDURE
6	HANDLING
7	MAINTENANCE AND INSPECTION
8	EMC DIRECTIVE

## 6.8 Printer Interface Module

The printer interface module is connected to the GOT when the printer is used with the GOT. The printer is used to print the data and others of the alarm history and hard copy functions. Refer to the following manual for details of the corresponding functions.

- When GT Designer is used : Help function of GT Designer
- When GT Designer2 is used : GT Designer2 Version □ Reference Manual

### 6.8.1 Printer interface module type

The following printer interface module type is available.

Type	Description
A9GT-50PRF	Printer interface module

### 6.8.2 How to connect the printer interface module

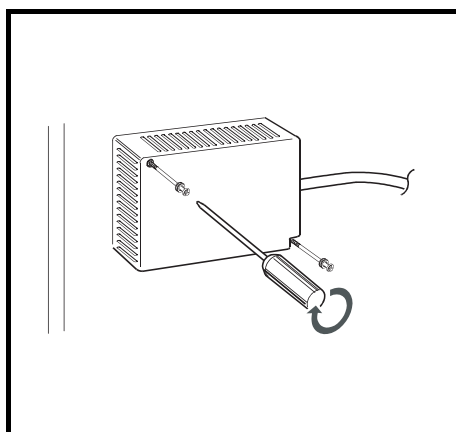

1) Thread A9GT-50PRF mounting screw holes in the control box or the like. (2-  $\phi$  3.5 mounting holes)

The A9GT-50PRF's GOT connection cable is 50cm long. Install the A9GT-50PRF within this distance so that the GOT-end connector of the cable may be fitted into the GOT's connector.

When mounting the A9GT-50PRF on the back of control box door, exercise care to avoid screw holes passing through the control box surface.

2) Tighten the mounting screw to the specified torque range 39 to 59N · cm.

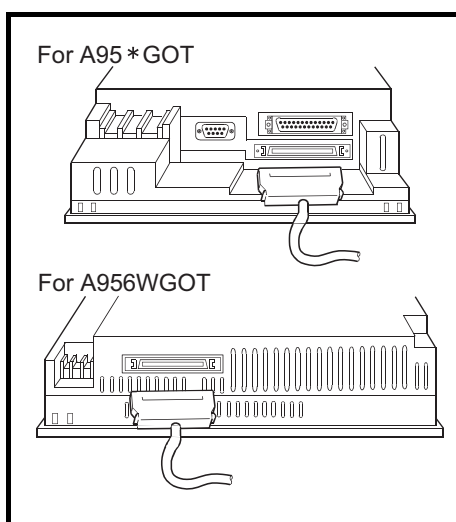

3) Plug the GOT side connector of the A9GT-50PRF to the option unit at the bottom of the GOT.

- For details of the printer interface module specifications, refer to the A9GT-50PRF type printer interface module User's Manual.

## 6.8.3 Printer types

The printer usable is any of the printers having the following specifications (standard) whose operations have been checked by Mitsubishi.

- ESC/P24-J84-compliant printer (ESC/P command-compatible, color-compatible)
- Hewlett Packard printers (PLC command compatible)

For the operation-confirmed models, refer to the separately available document "List of operation-confirmed devices for GOT900 series" (Technical bulletin T10-0028).

When the document is necessary, please contact your local Mitsubishi representative.

If the printer used is not given in the document, it may not operate properly.

The above document can be viewed on the Mitsubishi Electric FA Network Service On World Wide, MEL-FANSweb home page.

(MELFANSweb home page: <http://wwwf2.MitsubishiElectric.co.jp/melfansweb/english/>)

## 6.8.4 Connecting procedure

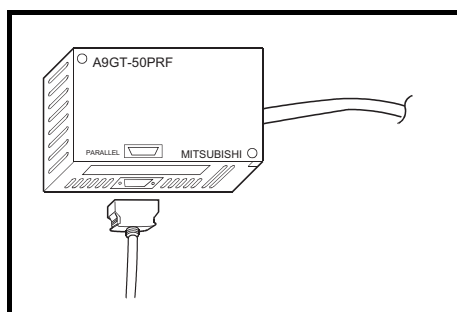

- 1) Plug the GOT side connector of the printer cable to the parallel interface of the A9GT-50PRF.
- 2) Connect the A9GT-50PRF and printer by the printer cable.

## 6.9 External I/O Module

The external I/O module is connected with the ten-key panel (A8GT-TK) or keyboard to receive up to 8/64 points of inputs or provide up to 16 points of outputs.

Refer to the following manual for details of the corresponding functions.

- When GT Designer is used : Help function of GT Designer
- When GT Designer2 is used : GT Designer2 Version  Reference Manual

### 6.9.1 External I/O module type

The following external I/O module is available.

Type	Description
A8GT-50KBF	External I/O module

### 6.9.2 Mounting procedure

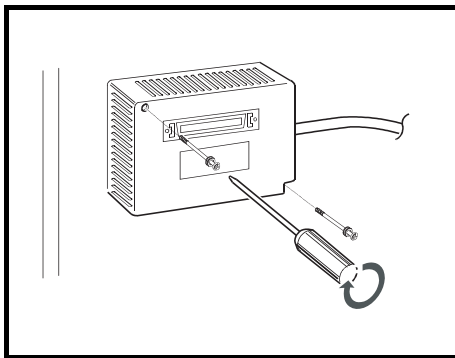

- 1) Thread A8GT-50KBF mounting screw holes in the control box or the like. (2- $\phi$  3.5 mounting holes)

The A8GT-50KBF's GOT connection cable is 50cm long. Install the A8GT-50KBF within this distance so that the GOT-end connector of the cable may be fitted into the GOT's connector.

When mounting the A8GT-50KBF on the back of control box door, exercise care to avoid screw holes passing through the control box surface.

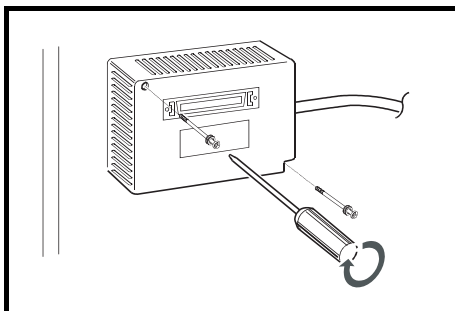

- 2) Tighten the mounting screws to the specified torque range 39 to 59N · cm.
- 3) Plug the GOT side connector of the A8GT-50KBF to the option unit of the GOT.

- When using the A8GT-50KBF, use the ROM\_BIOS of SW1D5C-GOTRE-PACK H version or later (ROM\_BIOS G version or later). (GT Works2 and GT Designer2 are compatible, starting with the initial products (Version 1.00A).)
- For details of the External I/O module specifications, refer to the A8GT-50KBF type External I/O module User's Manual.

## 6.10 Bar Code Reader

The bar code reader is used for writing data that is read with the bar code reader into the programmable controller CPU.

Refer to the following manual for details of the bar code function.

- When GT Designer is used : Help function of GT Designer
- When GT Designer2 is used : GT Designer2 Version □ Reference Manual

### 6.10.1 Bar code reader types

The bar-code reader, which has been confirmed to operate properly by Mitsubishi Electric, can be used. For the operation-confirmed models, refer to the separately available document "List of operation-confirmed devices for GOT900 series" (Technical bulletin T10-0028).

When the document is necessary, please contact your local Mitsubishi representative.

If the bar-code reader used is not given in the document, it may not operate properly.

The above document can be viewed on the Mitsubishi Electric FA Network Service On World Wide, MEL-FANSweb home page.

(MELFANSweb home page: <http://wwwf2.MitsubishiElectric.co.jp/melfansweb/english/>)

### 6.10.2 Connecting procedure

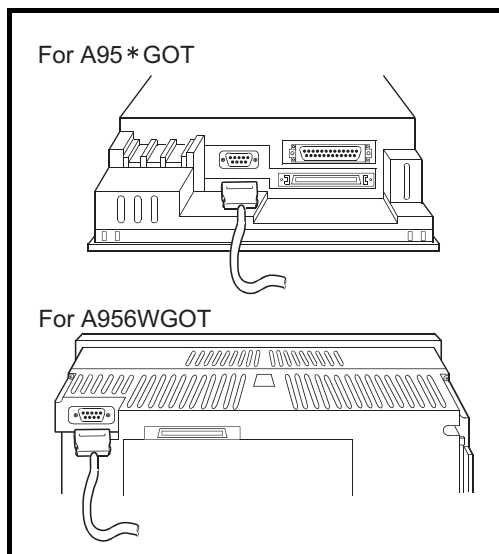

- 1) To the RS-232C interface of the GOT, choose and connect one from the following: the connector for the bar code reader; the connector for the power supply module; and the connector on the GOT for the RS-232C cable. (The connecting method differs depending on the kind of bar code reader that will be used.)

- Please note that the bar code reader cannot be used if the GOT is connected to the MELSECNET/B or MELSECNET II.
- The power supply (5V DC) needs to be supplied from an AC-DC adapter or a corresponding power module to the bar code reader.
- The RS-232C cable needs to be prepared by the user of this product.

For details of preparations of the cable, please refer to the ["List of operation-confirmed devices for GOT900 series" (Technical bulletin T10-0028)]

## 6.11 Debug Stand

---

The debug stand is used to secure the GOT in a standing position so that the monitor screen data may be debugged easily.

### 6.11.1 Debug stand type

---

The following debug stand type is available.

Type	Description
A9GT-50STAND	Debug stand for A95*GOT
A9GT-50WSTAND	Debug stand for A956WGOT

### 6.11.2 Mounting procedure

---

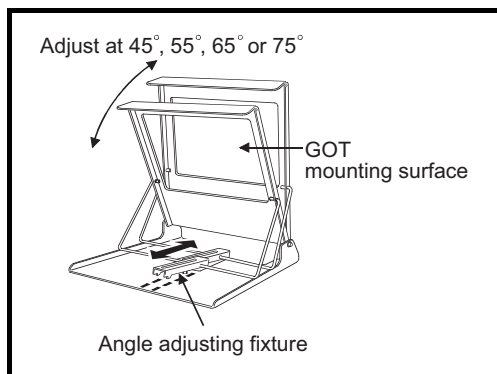

- 1) Adjust the GOT mounting angle with the angle adjusting fixture of the debug stand.
  - 2) Put the GOT into the front face of the debug stand and mount it on the debug stand with the mounting fixtures of the GOT main unit.
- Refer to [Section 6.1.2] for the installation method using the mounting fixtures of the GOT main unit.

- For details of the debug stand specifications, refer to the A9GT-50STAND User's Manual or A9GT-50WSTAND User's Manual.



## 6.12 Attachment (A95\*GOT only)

The attachment is used to replace the A85\*GOT with the A95\*GOT.  
By the use of the attachment, additional machining to the installation hole in the control panel of the A85\*GOT can be eliminated.

### 6.12.1 Attachment type

The following Attachment type is available.

Type	Model in use	Applicable model
A85GT-95ATT	A85*GOT	A95*GOT

### 6.12.2 Mounting procedure

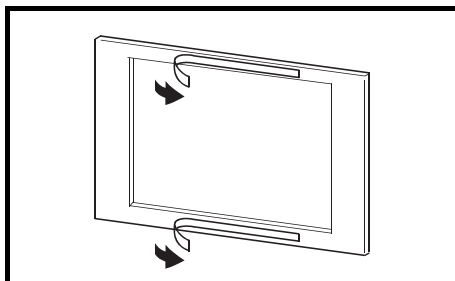

- 1) Peel off the pressure sensitive adhesive double coated tape from the rear surface of the attachment.

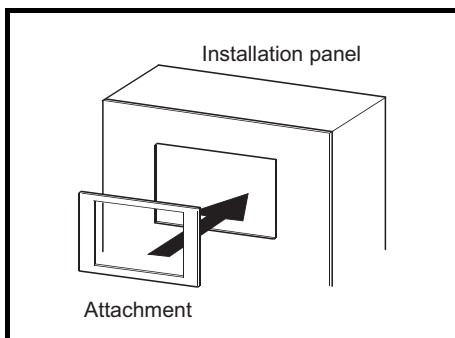

- 2) Install the attachment securely taking care so that it is positioned correctly in the installation panel mounting hole. If the installation panel is dirty, the attachment may fall, causing injury. Ensure to clean the installation panel by wiping it off before installation of the attachment.

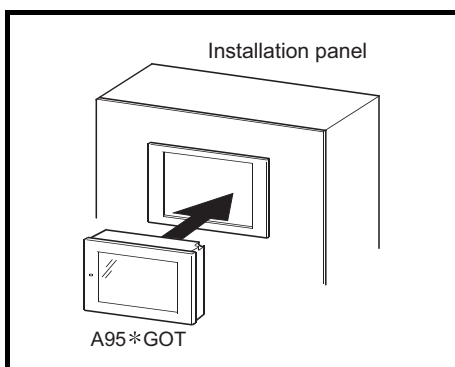

- 3) Insert the GOT main unit from the front of the attachment, and tighten it to the specified torque using the mounting screws furnished with the GOT main unit.

- The attachment can be used when the plate thickness of the installation panel is 1.2 (0.05) to 3 mm (0.12 in).  
When the plate thickness exceeds 3 mm (0.12 in), the attachment cannot be used for the replacement of the GOT.
- Once the GOT has been replaced with a new GOT by the use of the attachment, the new GOT does not meet the requirements specified in the standards for water and dust resistance IP65/IP67/NEMA4.

# 7 MAINTENANCE AND INSPECTION

---

This chapter explains the items which should be performed daily or periodically to use the GOT to its optimum.

## 7.1 Instructions for Maintenance and Inspection

---

The following instructions should be observed for maintenance and inspection.

### DANGER

- When power is on, do not touch the terminals.  
Doing so can cause an electric shock or malfunction.
- Before starting cleaning or terminal screw retightening, always switch off the power externally in all phases.  
Not switching the power off in all phases can cause a module failure or malfunction.  
Undertightening can cause a short circuit or malfunction.  
Overtightening can cause a short circuit or malfunction due to the damage of the screws or module.
- Before changing the backlight, always turn the GOT power OFF (When using a GOT bus connection, also turn OFF the PLC CPU power), and remove the GOT main unit from the panel before changing the backlight.  
Not switching the power off in all phases may cause an electric shock.  
Not removing the unit from the enclosure can cause injury due to a drop.

### CAUTION

- Do not disassemble or modify the module.  
Doing so can cause a failure, malfunction, injury or fire.
- Do not touch the conductive and electronic parts of the module directly.  
Doing so can cause a module malfunction or failure.
- The cables connected to the module must be run in ducts or clamped.  
Not doing so can cause the module or cable to be damaged due to the dangling, motion or accidental pulling of the cables or can cause a malfunction due to a cable connection fault.
- When unplugging the cable connected to the module, do not hold and pull the cable portion.  
Doing so can cause the module or cable to be damaged or can cause a malfunction due to a cable connection fault.
- When disposing of the product, handle it as industrial waste.
- While changing the backlight, do not touch the circuit boards and electronic parts of the GOT.  
Doing so can cause a failure or malfunction.
- When replacing the backlight, use the gloves.  
Otherwise, it may cause you to be injured.  
If you should directly touch the plated area of the main unit case with hand, be sure to wipe off the fingerprint and so on, and install the main unit case.  
Otherwise, it may cause a trouble or malfunction.
- Start changing the backlight more than 5 minutes after switching the GOT power off.  
Not doing so can cause a burn due to the heat of the backlight.

## 7.2 Daily Inspection

Daily inspection items are as follows.

Number	Inspection Item	Inspection Method	Criterion	Action	
1	Module mounting status	Check for loose mounting screws and disconnected cover	Securely mounted	Retighten screws	
2	Connection status	Loose terminal screws	Retighten screws with screwdriver	Not loose	Retighten terminal screws
		Proximate solderless terminals	Visual check	Proper intervals	Correct
		Loose connectors	Visual check	Not loose	Retighten connector fixing screws

## 7.3 Periodic Inspection

Inspection items to be checked once or twice in six months or one year are as follows.

The following inspection should also be performed when equipment has been moved or modified or the wiring changed.

Number	Inspection Item	Inspection Method	Criterion	Action	
1	Surrounding environment	Ambient temperature Ambient humidity Atmosphere Make measurement with thermometer or hygrometer Measure corrosive gas	Display section	0 to 40°C	For use in enclosure, temperature inside enclosure is ambient temperature
			Other portions	0 to 55°C	
			10 to 90%RH		
			No corrosive gas		
2	Power supply voltage check	24VDC Measure voltage across terminals	20.4DC to 26.4V	Change supply power	
3	Mounting status	Looseness	Move module	Should be mounted firmly	Retighten screws
		Dirt, foreign matter	Visual check	No dirt, foreign matter sticking	Remove, clean
4	Connection status	Loose terminal screws	Retighten screws with screwdriver	Not loose	Retighten terminal screws
		Proximate solderless terminals	Visual check	Proper intervals	Correct
		Loose connectors	Visual check	Not loose	Retighten connector fixing screws

## 7.4 How to Change the Backlight for Liquid Crystal



The A95\*GOT-TBD(-M3), A95\*GOT-SBD(-M3)-B and A956WGOT do not require their backlights to be replaced since they are installed with long-life backlights.

The GOT contains a backlight for the liquid crystal of the display device.

The luminance of the back light lowers as it is used.

Change the backlight if the screen of the display device has become difficult to look at due to the reduced luminance of the backlight.

Change the backlight in the following procedure.

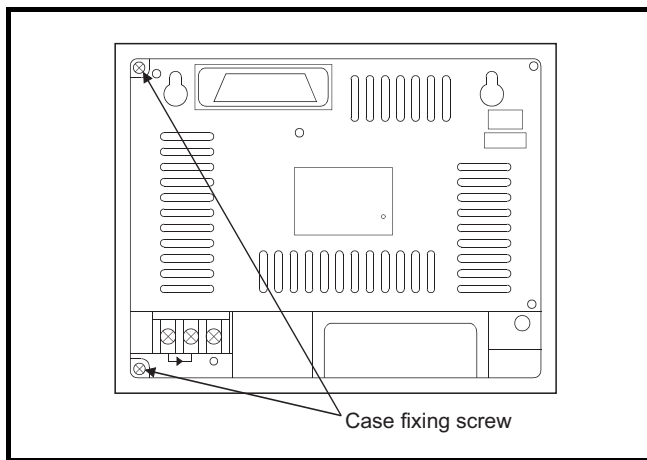

- 1) Turn the GOT's power off.  
Remove the wire from the power supply terminal and also remove the communications cable.  
When using the A956GOT, remove the network module.
- 2) After loosening the mounting fixtures of the GOT, remove the GOT from the enclosure.
- 3) Remove the fixing screws (2 pcs.) in the back of the GOT with a screwdriver.

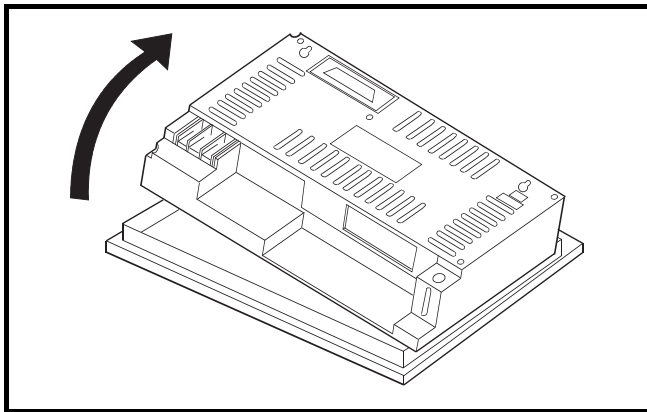

- 4) Remove the case on the back of the GOT.

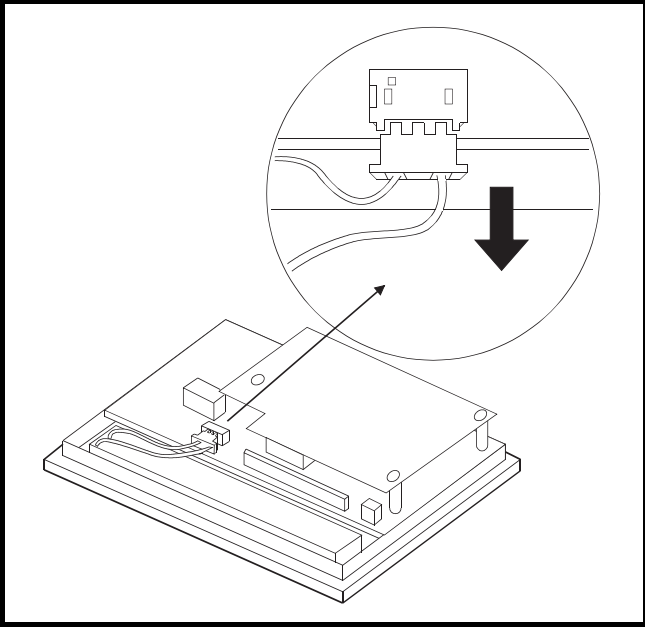

5) Unplug the cable connector of the backlight from the connector of the display device.

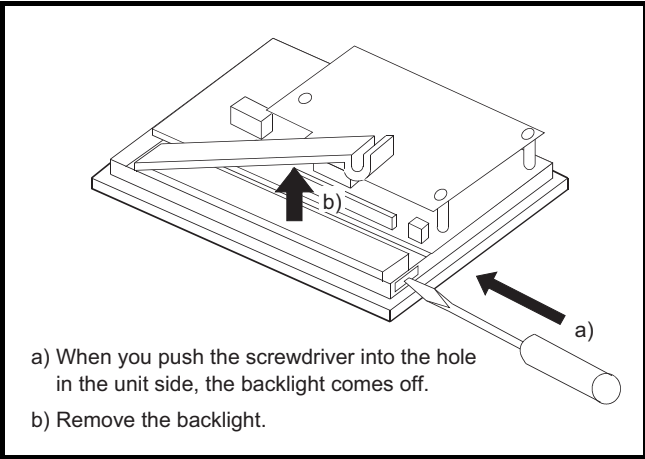

6) Remove the backlight from the display device. Using a flat-blade screwdriver makes removal easy.

7) Fit a new backlight in the reverse procedure of removal. To install the display unit, please follow the procedure reverse to that for removing. Please make sure to install the display unit securely and apply a torque within the torque range as specified to the fixing screws for the GOT.

\* When changing the backlight, use care not to touch the circuit board in the GOT.

## [Disposal Instructions]

### ⚠ CAUTION

- To dispose of, please treat the back light as an industrial waste.

# 8 EMC DIRECTIVE

---

For the products sold in European countries, the conformance to the EMC Directive, which is one of the European Directives, has been a legal obligation since 1996. Also, conformance to the Low Voltage Directive, another European Directives, has been a legal obligation since 1997.

Manufacturers who recognize their products must conform to the EMC and Low Voltage Directives required to declare that their products conform to these Directives and put a "CE mark" on their products.



Products that the EMC directive applies to are marked with the CE mark logo.

## 8.1 Requirements for conformance to EMC Directive

---

The EMC Directive specifies that products placed on the market must "be so constructed that they do not cause excessive electromagnetic interference (emissions) and are not unduly affected by electromagnetic interference (immunity)".

The applicable products are requested to meet these requirements. The sections 8.1.1 through 8.3.3 summarize the precautions on conformance to the EMC Directive of the machinery constructed using the GOT. The details of these precautions has been prepared based on the requirements and the applicable standards control. However, we will not assure that the overall machinery manufactured according to these details conforms to the above-mentioned directives. The method of conformance to the EMC directive and the judgment on whether or not the machinery conforms to the EMC Directive must be determined finally by the manufacturer of the machinery.

## 8.1.1 Standards applicable to the EMC directive

Specification	Test item	Test details	Standard value
EN61131-2 : 2003	EN55011 Radiated noise *1	Electromagnetic emissions from the product are measured.	30M-230MHz QP: 30dB $\mu$ V/m(30m measurement range) *2, *3 230M-1000MHz QP: 37dB $\mu$ V/m(30m measurement range) *2, *3
	EN55011 Conducted noise *1	Electromagnetic emissions from the product to the power line are measured.	150k-500kHz QP: 79db, Mean: 66dB *2 500k-30MHz QP: 73dB, Mean: 60dB *2
	EN61000-4-2 Electrostatic immunity *1	Immunity test in which static electricity is applied to the cabinet of the equipment.	$\pm$ 4kV Contact discharge $\pm$ 8kV Aerial discharge
	EN61000-4-3 Radiated field AM modulation *1	Immunity test in which field is irradiated to the product.	80-1000MHz: 10V/m 1.4-2GHz: 10V/m 80%AM modulation @ 1kHz
	EN61000-4-4 Fast transient burst noise *1	Immunity test in which burst noise is applied to the power line and signal lines.	Power line: 2kV Digital I/O (24V or more): 1kV (Digital I/O (24V or less)) > 250V (Analog I/O, signal lines) > 250V
	EN61000-4-5 Surge immunity *1	Immunity test in which lightning surge is applied to the product.	DC power type Power line (between line and ground): $\pm$ 0.5kV Data communication port: $\pm$ 0.5kV
	EN61000-4-6 Conducted RF immunity *1	Immunity test in which a noise induced on the power and signal lines is applied.	Power line: 3V Data communication port: 3V
	Instantaneous power failure and voltage dips immunity	Test for checking normal operations at instantaneous power failure	DC power type 10ms (interval 1s or more)
	Radiated RF immunity	Test for checking normal operations when the power supply unit input voltage is fluctuated	DC power type 20.4V, 28.8V
External power supply fluctuation immunity	Test for checking if the unit becomes faulty with a transient voltage of the internal and external input sides of the power supply unit or unit power supply	DC power type 20.4V, 26.4V	

\*1 The GOT is an open type device (device installed to another device) and must be installed in a conductive control panel. The above test items are conducted in the condition where the GOT is installed on the conductive control panel and combined with the Mitsubishi PLC.

\*2 QP: Quasi-peak value, Mean: Average value

\*3 The above test items are conducted in the following conditions.

30-230MHz QP :40dB  $\mu$  pV/m (10m in measurement range)

230-1000MHz QP:47dB  $\mu$  pV/m (10m in measurement range)

## 8.1.2 Control cabinet

---

The GOT is an open type device (device installed to another device) and must be installed in a conductive control panel or cabinet.

It not only assure the safety but also has a large effect to shut down the noise generated from GOT, on the control panel.

(1) Control cabinet

(a) Use a conductive control cabinet.

(b) When attaching the control cabinet's top plate or base plate, mask painting and weld so that good surface contact can be made between the cabinet and plate.

(c) To ensure good electrical contact with the control cabinet, mask the paint on the installation bolts of the inner plate in the control cabinet so that contact between surfaces can be ensured over the widest possible area.

(d) Earth the control cabinet with a thick wire so that a low impedance connection to ground can be ensured even at high frequencies. (22mm<sup>2</sup> wire or thicker is recommended.)

(e) Holes made in the control cabinet must be 10 cm (3.94in.) diameter or less. If the holes are 10cm (3.94in.) or larger, radio frequency noise may be emitted.

In addition, because radio waves leak through a clearance between the control panel door and the main unit, reduce the clearance as much as practicable.

The leakage of radio waves can be suppressed by the direct application of an EMI gasket on the paint surface.

Our tests have been carried out on a panel having the damping characteristics of 37 dB max. and 30 dB mean (measured by 3 m method with 30 to 300 MHz).

(2) Connection of power and ground wires

Ground and power supply wires for the GOT must be connected as described below.

(a) Provide an earthing point near the GOT. Earth the power supply's FG terminal (FG: Frame Ground) with the thickest and shortest wire possible. (The wire length must be 30cm (11.18in.) or shorter.)

The FG terminal function is to pass the noise generated in the GOT to the ground, so an impedance that is as low as possible must be ensured.

As the wires are used to relieve the noise, the wire itself carries a large noise content and thus short wiring means that the wire is prevented from acting as an antenna.

Note) A long conductor will become a more efficient antenna at high frequency.



- (3) Electrical shock prevention  
In order to such as the operators from electric shocks, the control box must have the following functions :
- (a) The control cabinet must be equipped with a lock so that only skilled or qualified personnel.
  - (b) The control cabinet must be fitted with advice which automatically stops the power supply when the cabinet is opened.
- (4) Dustproof and waterproof features  
The control box also has the dustproof and waterproof functions. Insufficient dustproof and waterproof features lower the insulation withstand voltage, resulting in insulation destruction. The insulation in our GOT is designed to cope with the pollution level 2, so use in an environment with pollution level 2 or better.
- Pollution level 1: An environment where the air is dry and conductive dust does not exist.
- Pollution level 2: An environment where conductive dust does not usually exist, but occasional temporary conductivity occurs due to the accumulated dust.  
Generally, this is the level for inside the control box equivalent a control room or on the floor of a typical factory.
- Pollution level 3: An environment where conductive dust exists and conductivity may be generated due to the accumulated dust.  
An environment for a typical factory floor.
- Pollution level 4 : Continuous conductivity may occur due to rain, snow, etc.  
An outdoor environment.

### 8.1.3 Grounding

It is necessary to use the GOT grounding terminal only when it is in the grounded condition. Be sure to ground the grounding for the safety reasons and EMC Directives.

Functional grounding  : Improves the noise resistance.

## 8.2 System Configuration when EMC Directive is Applicable

Connection conditions and models where the EMC directive is applicable are shown below.

### 8.2.1 Overall configuration

(1) For A95\*GOT

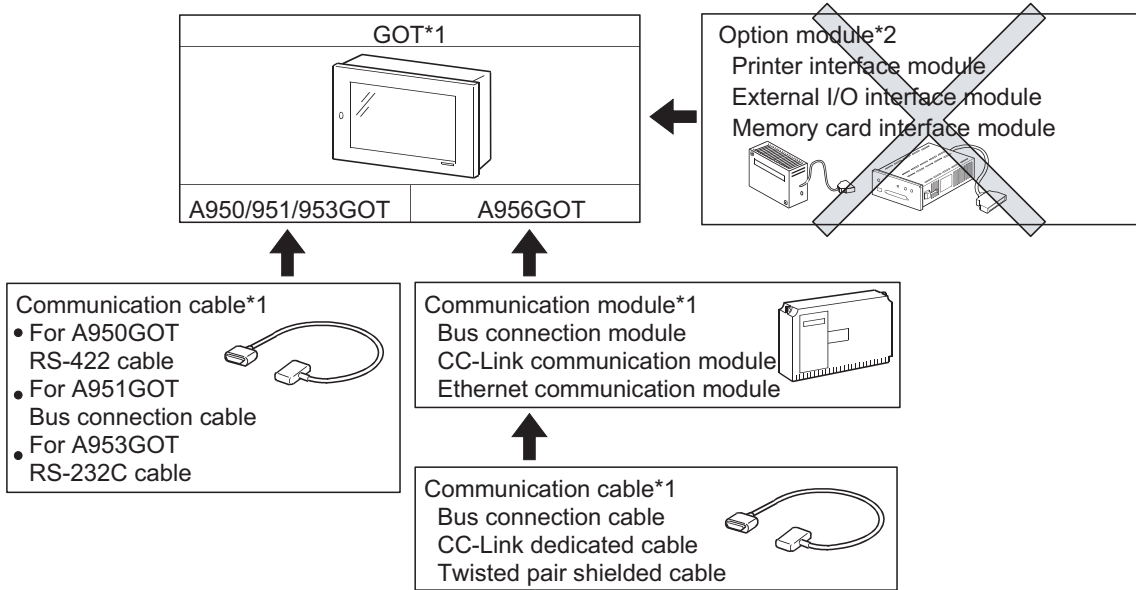

(2) For A956WGOT

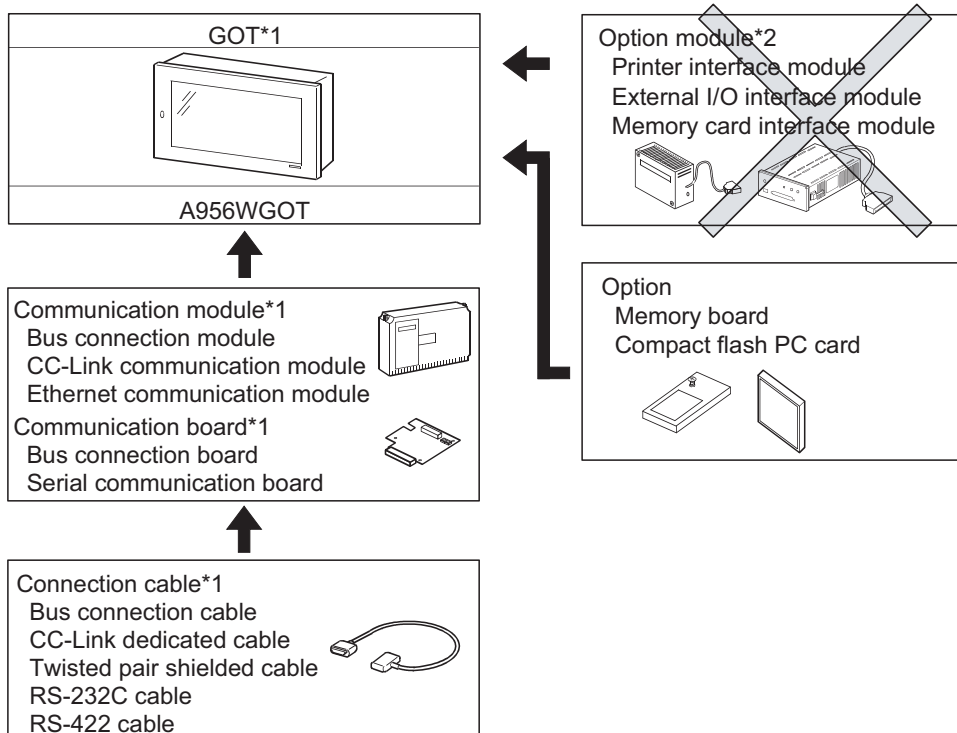

\*1 See section 8.2.3 for information about models and hardware versions that are applicable to the EMC directive.

\*2 EMC directive is not applicable when using an option module.

## 8.2.2 About modules applicable to the EMC directive

The following table lists the modules compliant with the EMC directive.

○ : Compliant with EMC directive × : Not compliant with EMC directive

Item	Type	EMC Directive
A950GOT (Built-in RS-422 communication interface)	A950GOT-TBD(-M3)	
	A950GOT-SBD(-M3)	○
	A950GOT-SBD(-M3)-B	○
	A950GOT-LBD(-M3)	○
A951GOT-Q (Built-in bus communication interface for Q CPU (Q mode))	A951GOT-QTBD(-M3)	×
	A951GOT-QSBD(-M3)	×
	A951GOT-QSBD(-M3)-B	×
	A951GOT-QLBD(-M3)	×
A951GOT (Built-in bus communication interface for A/QnA/Motion controller CPU)	A951GOT-TBD(-M3)	×
	A951GOT-SBD(-M3)	○
	A951GOT-SBD(-M3)-B	○
	A951GOT-LBD(-M3)	○
A953GOT (Built-in RS-232C communication Interface)	A953GOT-TBD(-M3)	×
	A953GOT-SBD(-M3)	○
	A953GOT-SBD(-M3)-B	○
	A953GOT-LBD(-M3)	○
A956GOT (Built-in communication module Interface)	A956GOT-TBD(-M3)	×
	A956GOT-SBD(-M3)	○
	A956GOT-SBD(-M3)-B	○
	A956GOT-LBD(-M3)	○
A956WGOT (Built-in communication module Interface)	A956WGOT-TBD	○

\*1 Be aware that if using A950GOT after removing the control panel as described in item 6.1.4, it is not applicable to the EMC directive.



If connecting to a PLC not from this company (MELSEC-Q series, MELSEC-QnA series, MELSEC-A series), refer to the manual of the connected device (PLC, microcomputer) for information about the applicability of the EMC directive

1	OVERVIEW
2	SYSTEM CONFIGURATION
3	PERFORMANCE
4	NAMES OF THE PARTS AND THEIR SETTINGS
5	ROUGH PRE-OPERATION PROCEDURE
6	HANDLING
7	MAINTENANCE AND INSPECTION
8	EMC DIRECTIVE

## 8.2.3 Connection format

Connection conditions where the A95\*GOT is applicable to the EMC directive are shown below.

× : Not compliant with EMC directive - : Connection impossible

Connection format		A950GOT	A951GOT-Q	A951GOT	A953GOT	A956GOT	A956WGOT
Bus Connection	QCPU	-	×	-	-	×	×
	QnA/ACPU	-	-	L(0105)	-	K(0105)	E(0203)
CPU direct connection	QCPU (RS-232C)	-	-	-	L(0105)	-	E(0203)
	QnA/ACPU (RS-422)	L(0105)	-	-	-	-	E(0203)
Computer link connection	RS-232C	-	-	-	L(0105)	-	E(0203)
	RS-422	L(0105)	-	-	-	-	E(0203)
MELSECNET connection		-	-	-	-	×	×
CC-Link connection	Intelligent device	-	-	-	-	K(0105)	E(0203)
	Remote device station	-	-	-	-	K(0105)	×
Ethernet connection		-	-	-	-	P(0203)	E(0203)

<How to read the table>

The table indicates the GOT-compatible hardware version for each connection pattern and the compatibility date.

Please use the GOT whose hardware version is later than that described.

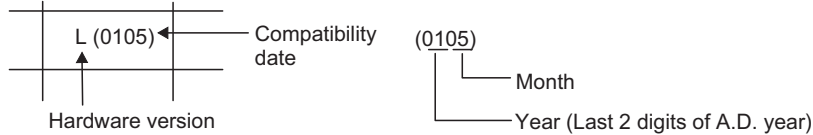

## 8.2.4 When the communication/board module is used

### (1) For A956GOT

Be sure to use the communication modules shown below with A956GOT. If communication modules other than those shown below are used, they are not applicable to the EMC directive.

Connection format	Communication module	
Bus connection (QnA/ACPU)	A9GT-BUSS (Hardware version C or later) A9GT-BUS2S (Hardware version C or later)	
CC-Link connection	Intelligent device	A8GT-J61BT13 (Hardware version E or later)
	Remote device	A8GT-J61BT15 (Hardware version C or later)
Ethernet connection	A9GT-J71E71-T (Hardware version C or later)	

(2) For A956WGOT

Be sure to use the communication boards/communication modules shown below with A956WGOT. If communication modules/communication boards other than those shown below are used, they are not applicable to the EMC directive.

Connection Format		Communication board/module
Bus connection		A9GT-50WBUSS (Hardware version B or later) A9GT-BUSSU (Hardware version B or later) A9GT-BUS2SU (Hardware version B or later)
CPU Direct connection	RS-232C	A9GT-50WRS2 (Hardware version B or later)
	RS-422	A9GT-50WRS4 (Hardware version B or later)
Computer link connection	RS-232C	A9GT-50WRS2 (Hardware version B or later)
	RS-422	A9GT-50WRS4 (Hardware version B or later)
CC-Link connection		A8GT-J61BT13 (Hardware version E or later)
Ethernet connection		A9GT-J71E71-T (Hardware version C or later)



Confirm the hardware version with the products rating plate.

(Products that the EMC directive applies to are marked with the CE mark logo.)

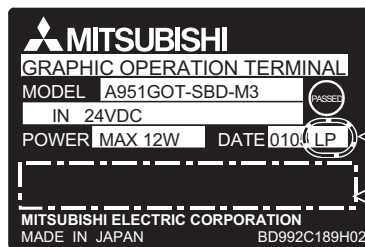

Hardware version  
Compliant standard marking is provided.

## 8.2.5 About the cable used

If making the GOT applicable to the EMC directive, be sure to use the cables shown below.

○: EMC directive applicable ×: EMC directive not applicable

Connection format		Cable	EMC Directive
Bus connection	A/QnACPU	AC06/12/30/50B, AC12/30/50B-R, A1SC07/12/30/50B, A1SC05/07/30/50NB, A8GT-C12/30/50NB, A370C12/25B, A9GT-J2C10B, A8GT-C100/200/300EXSS, A8GT-C100/200/300BS, A8GT-C100/200/300EXSS-1	○
	QCPU (Q mode)	QC06/12/30/50/100B, A9GT-QC150/200/250/300/350BS	×
CPU direct connection	RS-232C communication	QC30R2	○
	RS-422 communication	AC30/100/300R4-25P	○
Computer link connection	RS-232C communication	User created cable	○
	RS-422 communication	AC30/100/300R4-25P, User created cable	○
CC-Link connection		CC-Link dedicated cable	○
Ethernet connection		Category 5 Twisted pair shielded cable	○



To make applicable to the EMC directive, each cable (including user created cables) must be manufactured.

Refer to section 8.3.2 for the cable manufacturing method.

## 8.3 Wiring Precautions the Part which Matches the EMC Directives

Connect and wire GOT equipment as instructed below.

If the GOT equipment is configured in a way that differs from the following instructions then the system will not comply with EMC directives.

### 8.3.1 Method to connect the power wire and ground wire

- (1) With the power wire, be sure to attach the ferrite core (TDK type ZCAT3035-1330) within 90 mm of the GOT terminal module.  
Lead the power wire and ground wire as shown in Section 8.1.2 (2).  
Always ground the FG wires.

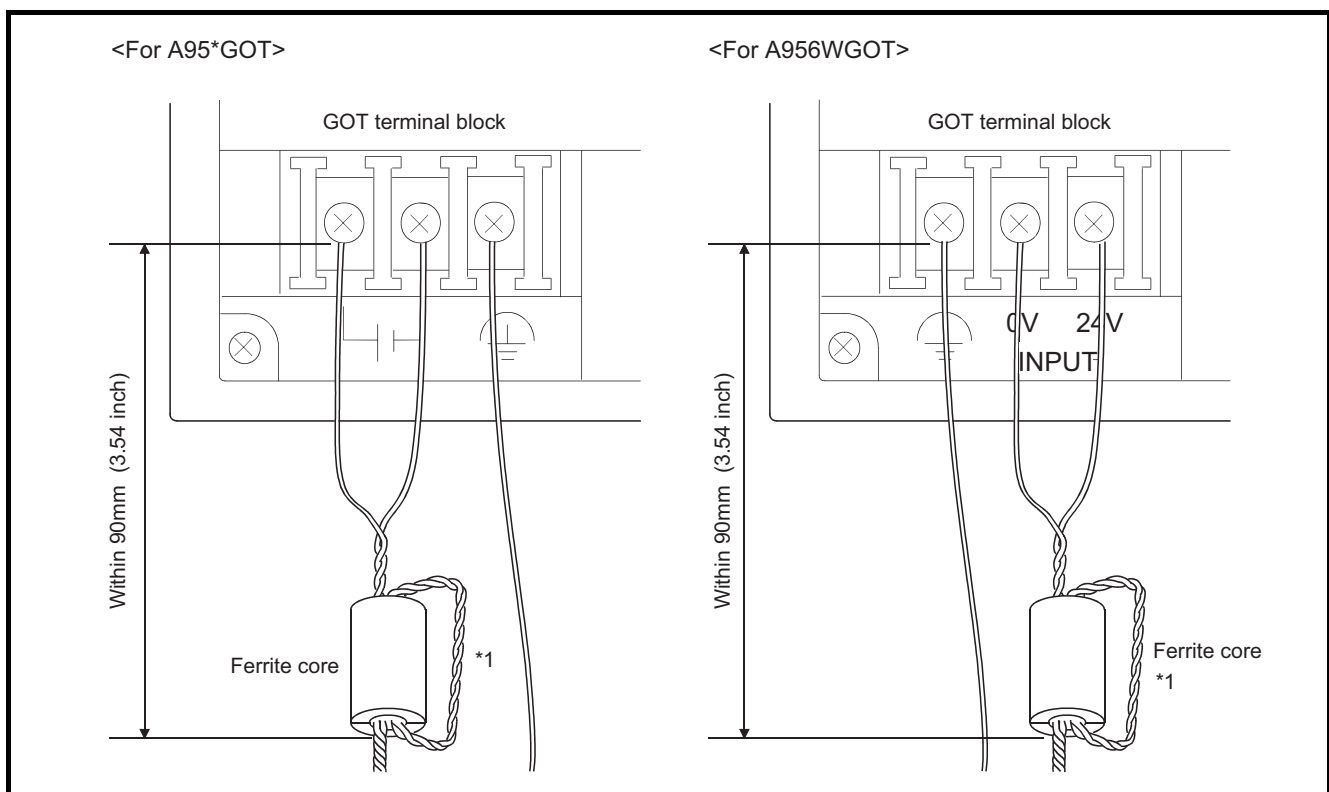

\*1 Wrap the power wire around the ferrite core.

- (a) When connecting CC-Link, use the grounding wire of the FG1 terminal on the CC-Link communication module to connect to the FG terminal of the GOT power section. Use a grounding wire of 300 mm or less.

<For A95\*GOT>

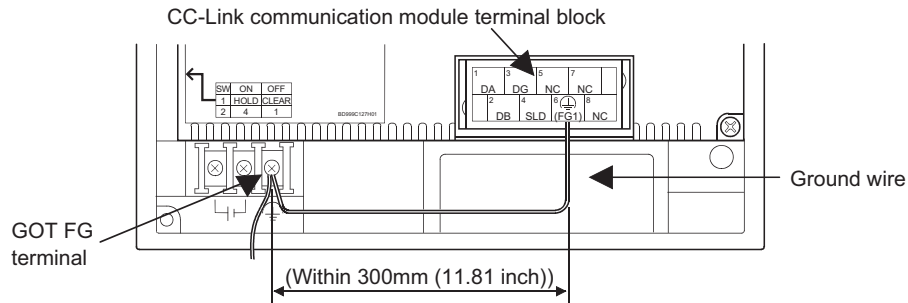

<For A956WGOT>

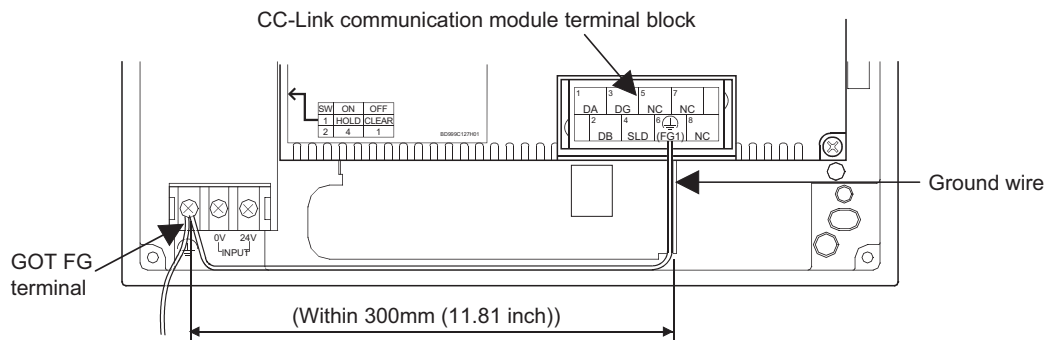

**Point**

Use a CE compatible product for 24 V DC external common power source for GOT. The EMC test run by our company was confirmed with the same panel components as the DENSEI-LAMBDA type JWS 50-24 or DLP120-24-1 installed.

### 8.3.2 Grounding the ground cable

Manufacture the cable used with the GOT with the following method.

When manufacturing the cable, a ferrite core, cable clamp and cable shielding material are required.

The cable clamp used by Mitsubishi Electric for the EMC specification compatibility test is shown below.

- TDK brand ZCAT3035-1330 Ferrite Core
- Mitsubishi Electric Model AD75CK cable clamp
- Japan Zipper Tubing Co., Ltd. Zipper tube SHNJ type

#### (1) Bus Connection

##### (a) For A8GT-C100/200/300EXSS

- Cut the ground wire from the core where it protrudes from both ends of the cable.

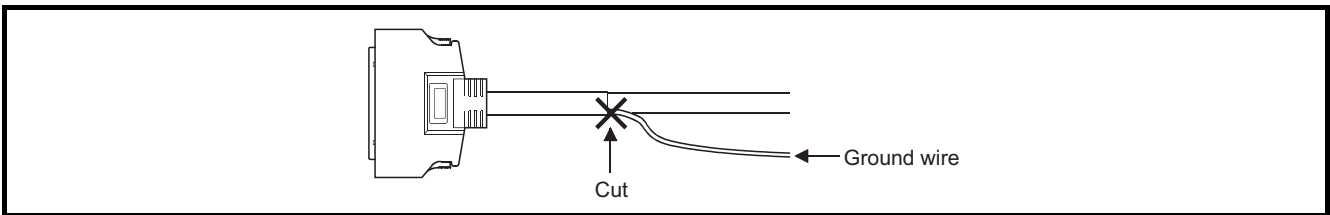

- Peel the sheath (with the length shown below) at both ends of the cable, and expose the shield braided wire for grounding.

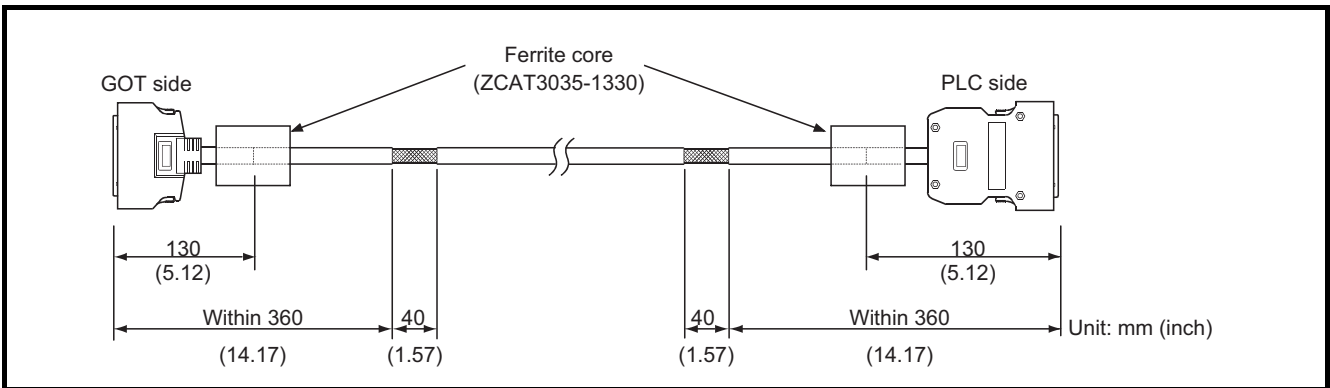

##### (b) For A8GT-C100/200/300BS

Cut the ground wire from the core where it protrudes from both ends of the cable.

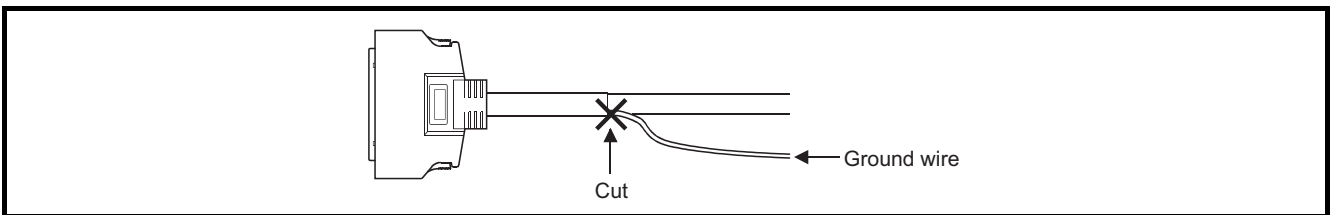



- Peel the sheath (with the length shown below) at both ends of the cable, and expose the shield braided wire for grounding..

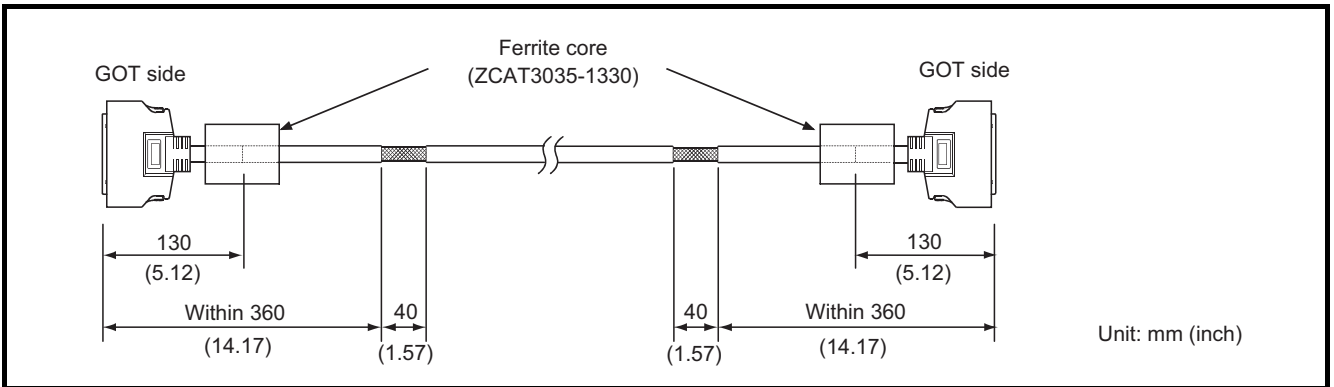

(c) For A8GT-C100/200/300EXSS-1



The A8GT-C100/200/300EXSS-1 is a combined product of the A8GT-EXCNB and A8GT-C100/200/300BS.

- Cut the ground wire from the core where it protrudes from the A8GT-EXCNB..

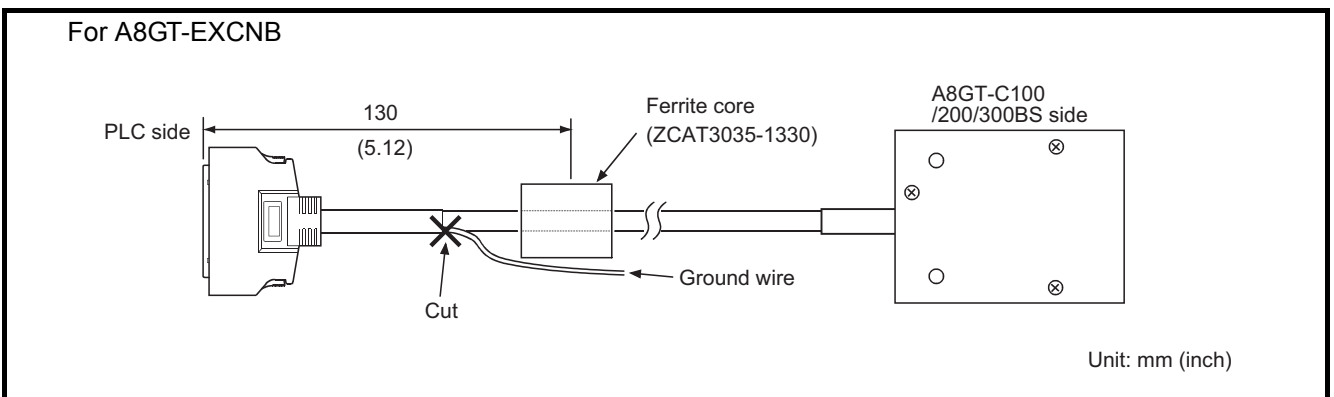

- Cut the ground wires protruding from both ends of the A8GT-C100/200/300BS with the length shown below.
- Peel the sheath (with the length shown below) at both ends, and expose the shield braided wire for grounding..

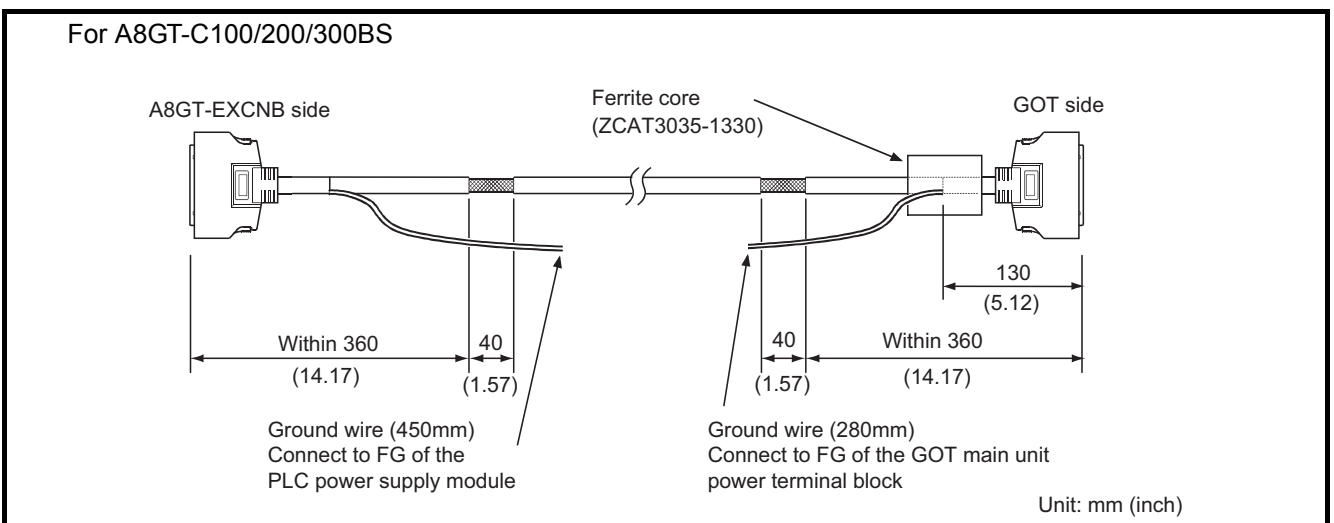

(d) For other Bus Connection cables

- Wrap the cable shield material around the cable, so that the back aluminum foil side (shield side) of the cable shield material is exposed at both ends of the cable..

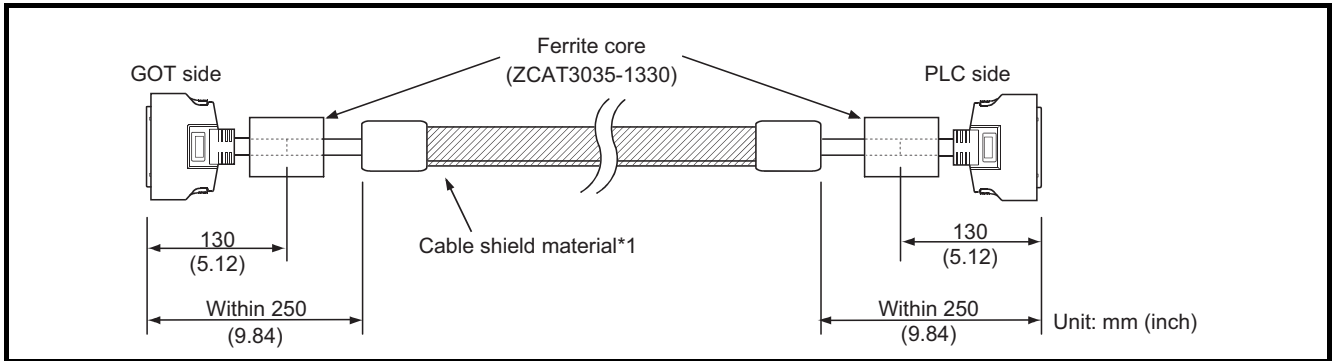

\*1 The back aluminum foil side of the cable shield material (shield side) should be exposed.

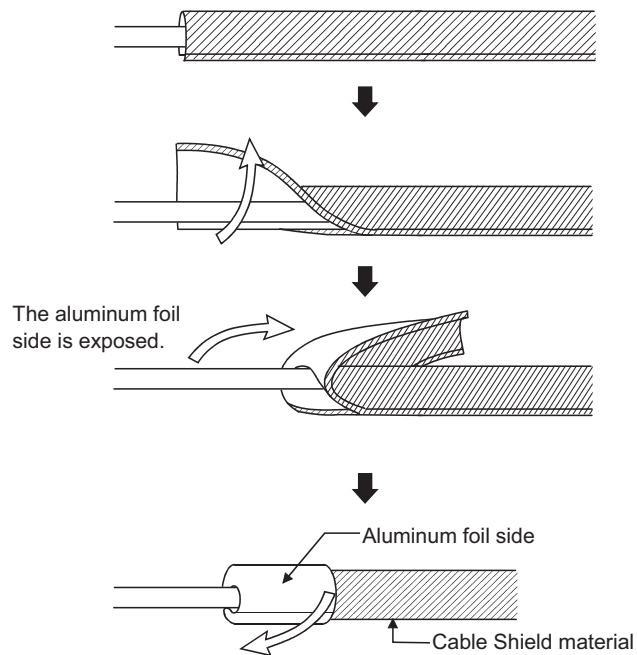

(2) CPU Direct Connection

(a) For RS-232C cable (QC30R2)

- Peel the sheath (with the length shown below) at both ends of the cable, and expose the shield braided wire for grounding..

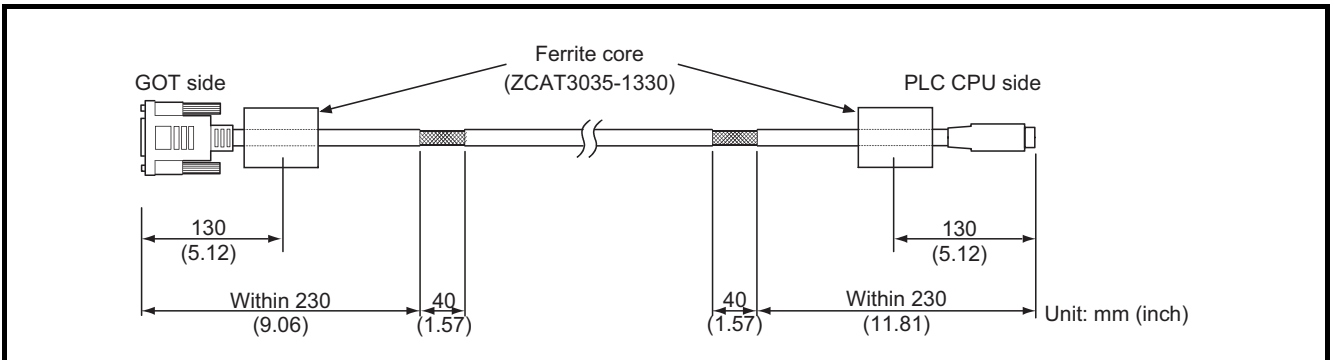

(b) For RS-422 cable (AC30/100/300R4-25P)

- Peel the sheath (with the length shown below) at both ends of the cable, and expose the shield braided wire for grounding..

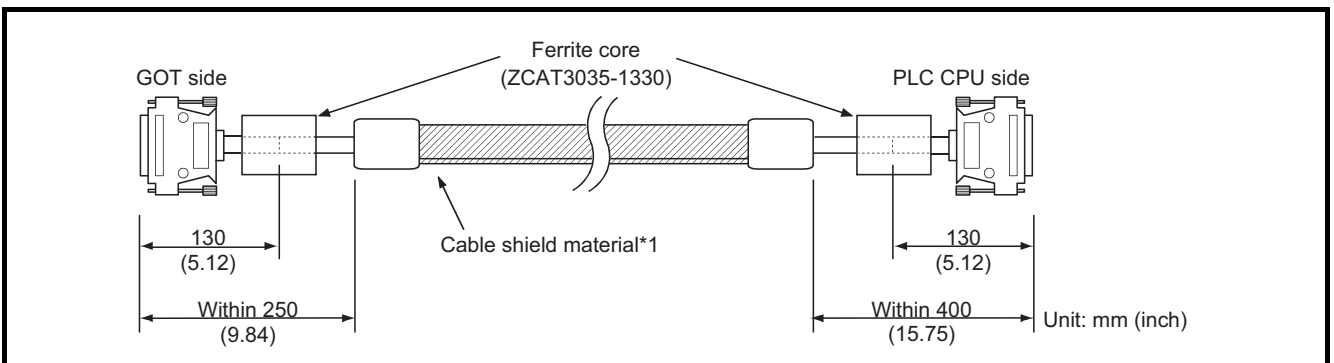

\*1 The back aluminum foil side of the cable shield material (shield side) should be exposed. (Refer to Section 8.3.2 (1) (b))

(3) Computer Link Connection

(a) For RS-232C cable

The user needs to fabricate the RS-232C cable which is used to connect the GOT and Computer link unit side (serial communication, computer link module or PLC CPU with computer link function).

The RS-232C cable connection diagram and the connector are as follows.

1) Connection diagram

- If D-sub 9-pin is used for the connector of the computer link unit.  
(A1SJ71QC24(-R2), A1SJ71UC24-R2, A1SJ71C24-R2, A1SCPUC24-R2, A2CCPUC24, QJ71C24(-R2), QJ71CMO)

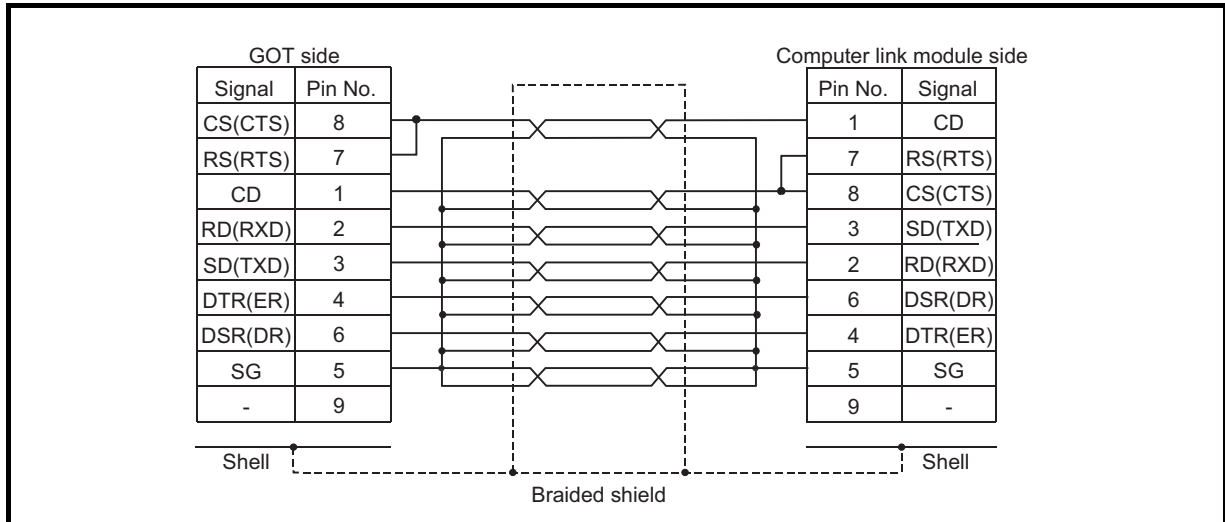

- If D-sub 25-pin is used for the connector of the computer link unit.  
(AJ71QC24(-R2), AJ71UC24)

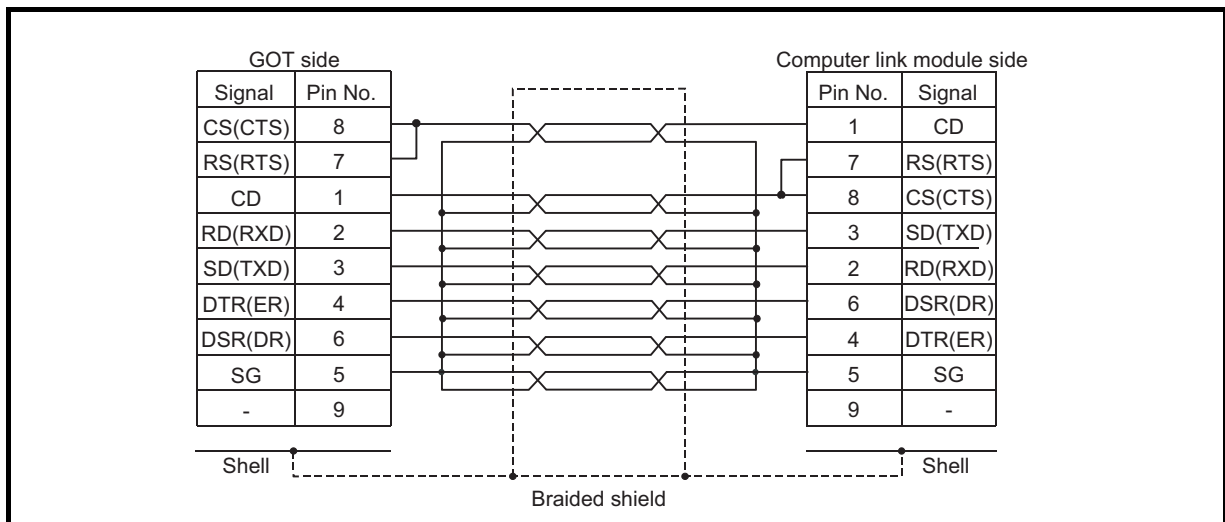

## 2) Precautions for manufacturing cable

- Make a twisted pair for each signal and SG.
- Connect the braided shield to the connector shell (both ends).
- The cable used for the Mitsubishi EMC Directive compatibility test had the following specifications.

Item	Specification
Cable type	Twisted pair shield cable
Conductor section area (mm <sup>2</sup> )	0.2

## 3) Connector (connector cover)

- GOT connector  
Use the connector matching the following model for the GOT.  
9-pin D-sub (male) inch screw type  
manufactured by DDK  
17JE-23090-27 (D3CC)
- Connector of computer link unit  
Refer to the user's manual of the serial communication, computer link module or PLC CPU with computer link function.

## 4) Cable production method

- Peel the sheath (with the length shown below) at both ends of the cable, and expose the shield braided wire for grounding.
- The cable must be 15m or shorter.

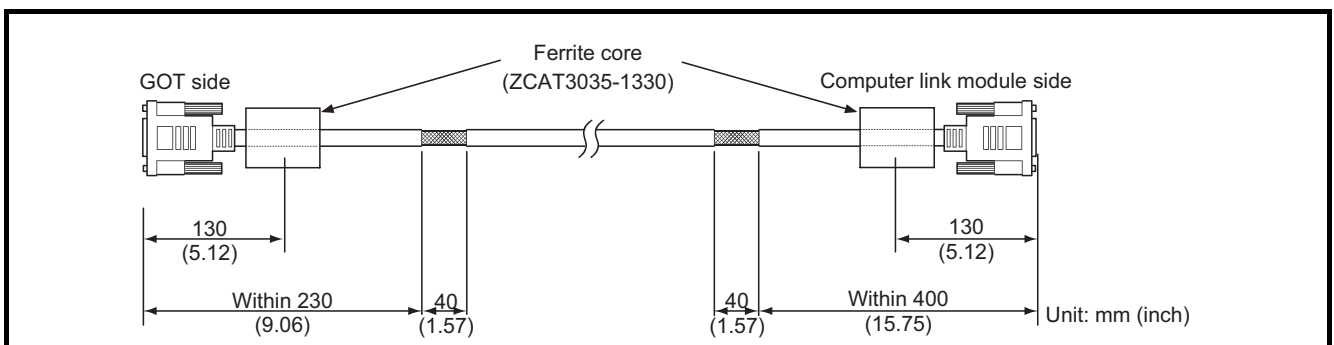

(b) For RS-422 cable (AC30/100/300R4-25P, User created cable)

Refer to the GOT-A900 series User's Manual (Connection System Manual) for information about the cable creation method.

- Wrap the cable shield material around the cable, so that the back aluminum foil side (shield side) of the cable shield material is exposed at both ends of the cable.

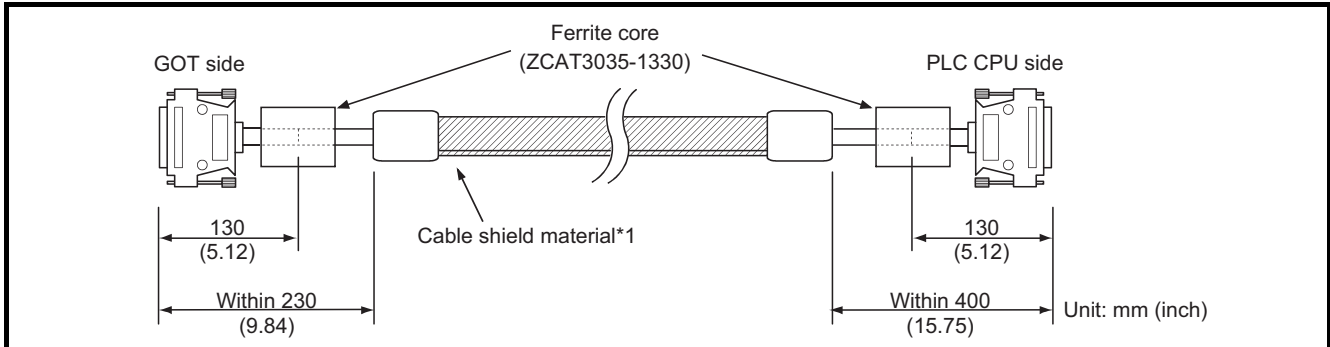

\*1 The back aluminum foil side of the cable shield material (shield side) should be exposed. (Refer to Section 8.3.2 (1) (b))

(4) CC-Link Connection (CC-Link dedicated cable)

- Peel the sheath (with the length shown below) at both ends of the cable, and expose the shield braided wire for grounding.

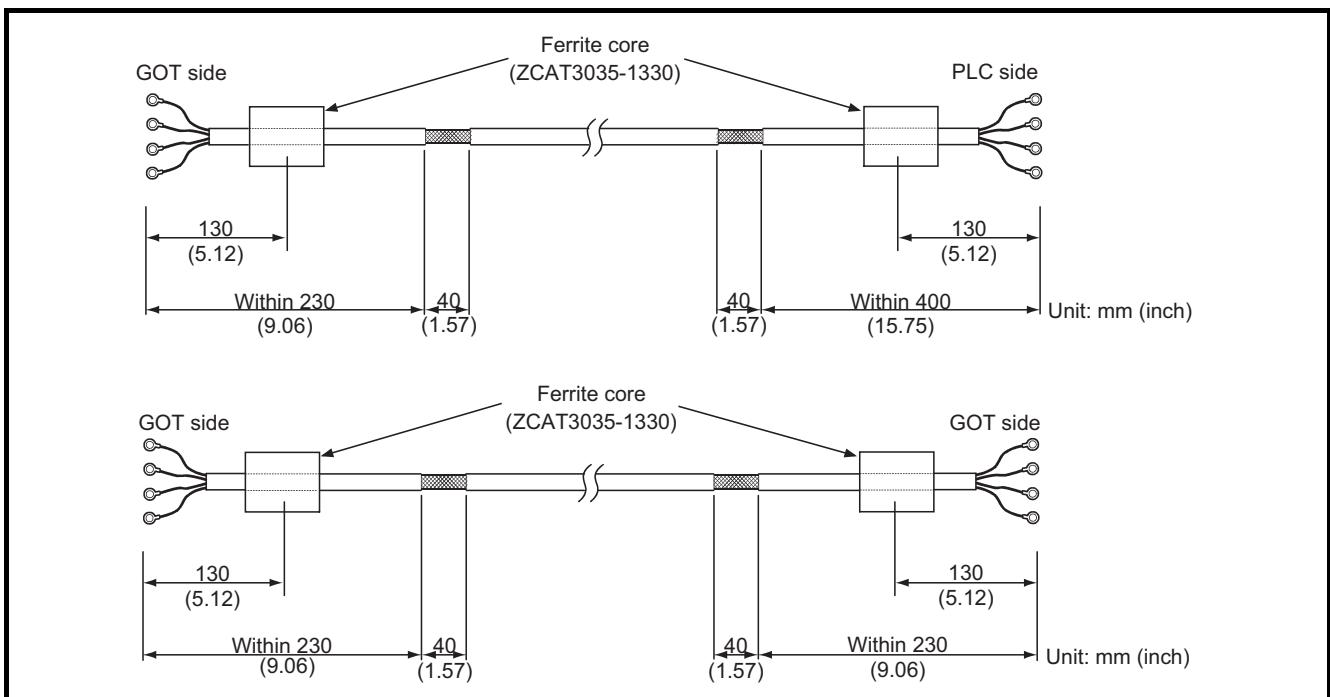

(5) Ethernet Connection (Twisted pair shield cable)

Peel the sheath (with the length shown below) at both ends of the cable, and expose the shield wire for grounding.

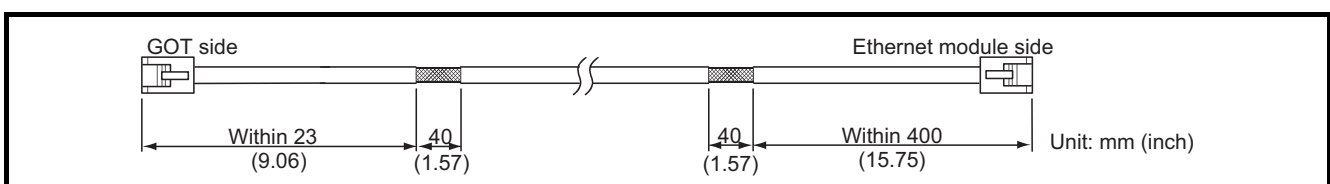

(6) Other PLC and Microcomputer connection

It is necessary for the user to create the cable used to connect GOT with a PLC or a microcomputer from another company (RS-422 cable or RS-232C cable).

Refer to the GOT-A900 series User's Manual (Connection System Manual) for information about the cable creation method.

**Point**

When connecting GOT to a PLC or microcomputer from another company, configure the system so that the EMC directive specifications from the connection destination are applicable.

The contents shown below are a collection of the contents that should be enforced when made applicable to the EMC directive; however, the final decision to make the device applicable to the EMC directive and how to make it applicable must be made by the manufacturer of the machine device.

(a) For RS-422 cable

- Each signal wire (excluding SG and FG) should be made into a two power wires and connected, then twisted.

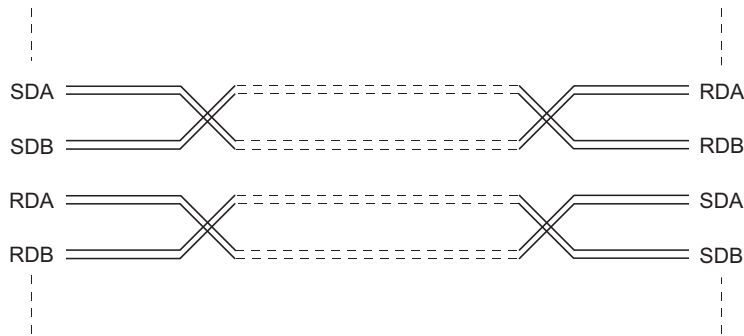

- Make the SG wire more than two wires and connect.
- Wrap the cable shield material around the cable, so that the back aluminum foil side (shield side) of the cable shield material is exposed at both ends of the cable.

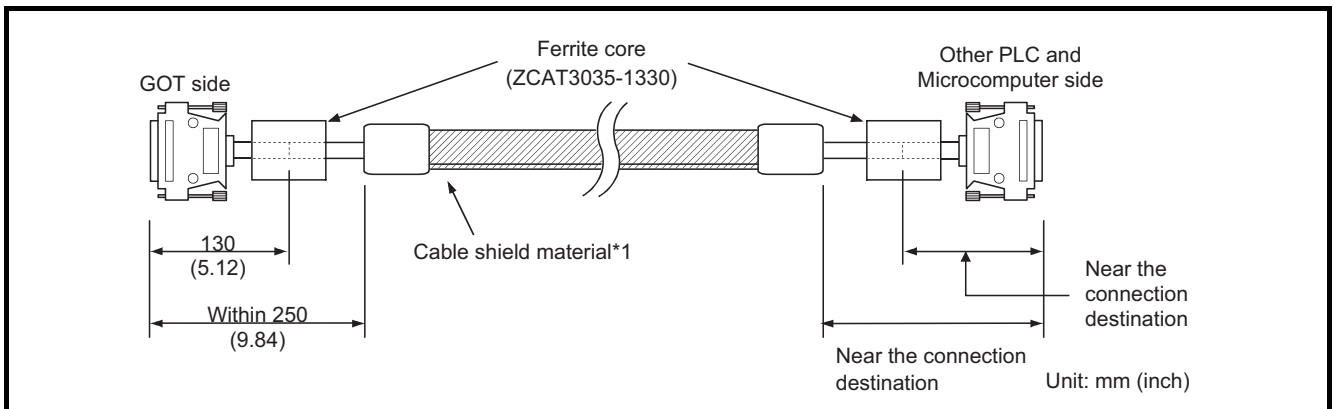

\*1 The back aluminum foil side of the cable shield material (shield side) should be exposed. (Refer to Section 8.3.2 (1) (b))

(b) For RS-232C cable

- Each signal wire (excluding SG, FG) is twisted with SG.

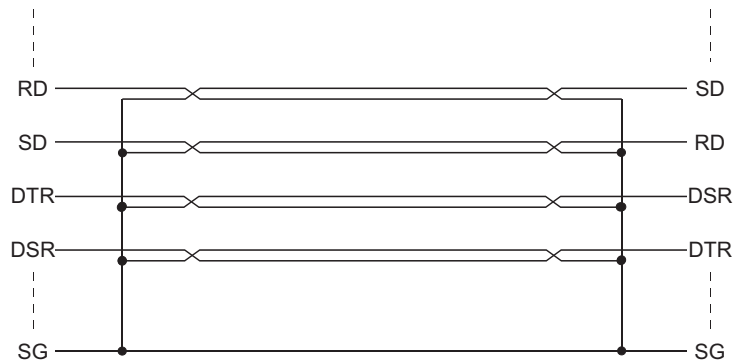

- Peel the sheath (with the length shown below) at both ends of the cable, and expose the shield braided wire for grounding.

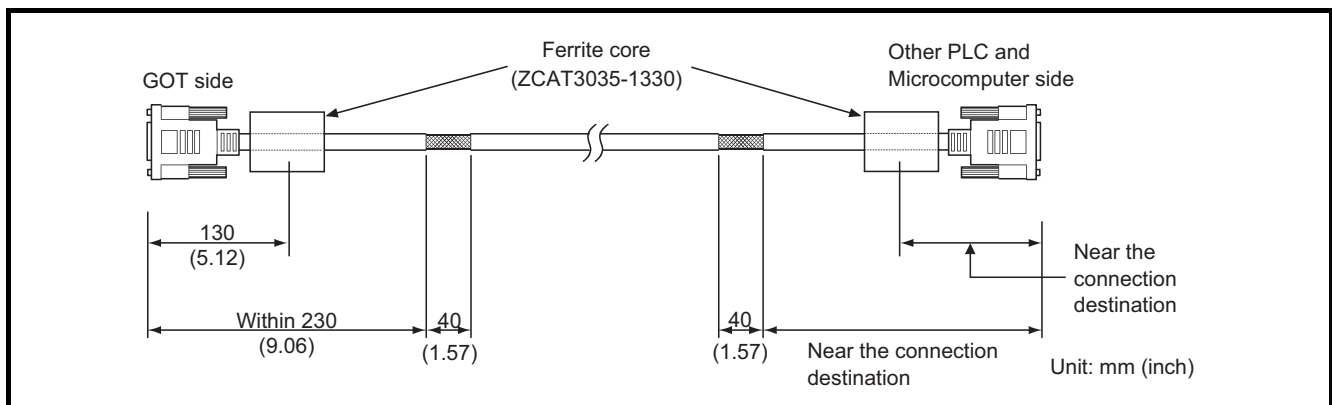

### 8.3.3 Grounding the cable

Ground the cable grounding sections and grounding wire to the control panel where the GOT and base unit are grounded.

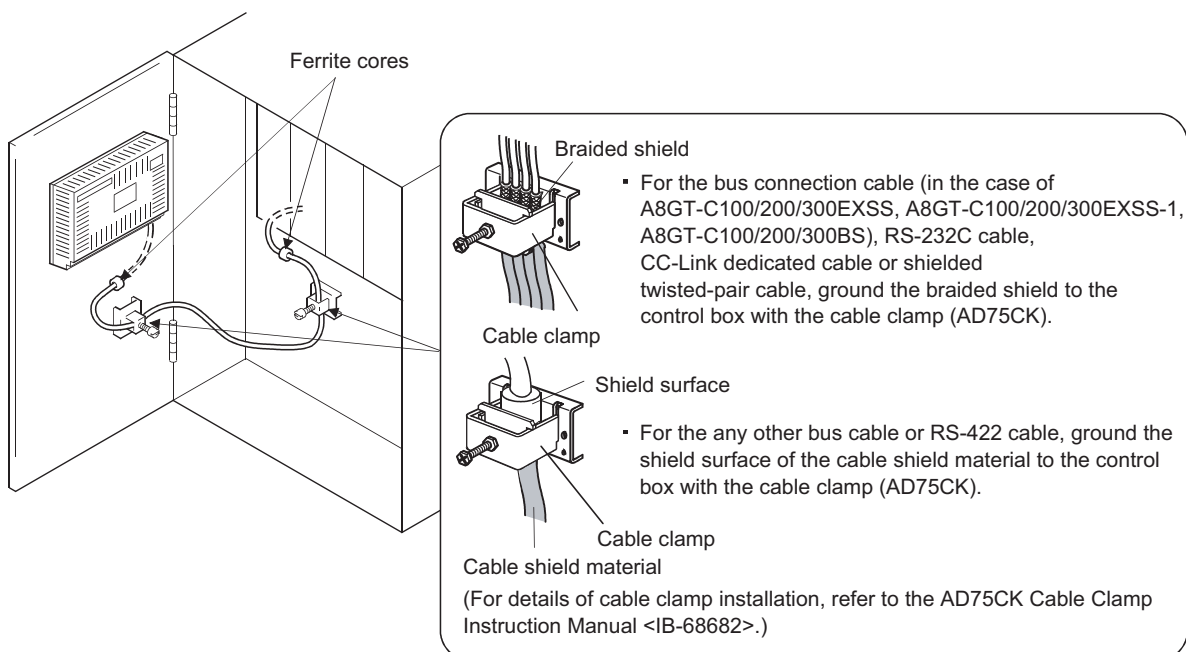



# 9 ERROR CODES AND ERROR MESSAGES

This chapter explains the error codes and error messages displayed by the alarm list (system alarm) display function of the monitoring functions.

The error codes may also be confirmed in the error code storage area of the system information function. Refer to the following manual for details of the alarm list (system alarm) function and system information function.

- When GT Designer is used : Help function of GT Designer
- When GT Designer2 is used : GT Designer2 Version □ Reference Manual

## 9.1 Definition of the Error Codes and Messages Displayed

This section describes the definition of the error codes and error messages displayed on the monitor screen by the alarm list (system alarm) display function and the manuals to refer to.

- (1) Display format on the monitor screen ----- Displayed in the user-set position



- (2) Error codes and manuals to refer to

Source of Error Occurrence	Error Code	Where to Refer To
ACPU	0 to 199 (Value of D9008)	[User's Manual of ACPU where GOT is connected]
MNET/B, MNET(II)	200 to 299	[Data Link System Reference Manual of MNET(II), MNET/B] *1
GOT	300 to 499	[Section 9.2]
MNET/10	500 to 799	[Network System Reference Manual of MNET/10] *2
CC-Link	800 to 999	[CC-Link System Master - Local Module User's Manual] *3
QnACPU	1000 to 9999 (Value of SD0)	[User's Manual of QnACPU where GOT is connected]

\*1 Take action with reference to the section explaining the link special relay of the (error code) + 9000.

For example, when the error of error code (210) has occurred,  $210 + 9000 = 9210$  and refer to the explanation of M9210 and take the corrective action.

\*2 Take action with reference to the section explaining the link special relay of the (error code) - 500.

For example, when the error of error code (510) has occurred,  $510 - 500 = 10$  and refer to the explanation of SB000A and take the corrective action.

(Since the link special relay is in hexadecimal, replace a decimal by a hexadecimal.)

\*3 Take action with reference to the section explaining the link special relay of the (error code) - 800.

For example, when the error of error code (910) has occurred,  $910 - 800 = 110$  and refer to the explanation of SB006E and take the corrective action.

(Since the link special relay is in hexadecimal, replace a decimal by a hexadecimal.)

\*4 The FXCPU has error codes 100 to 109 and displays the states of M8060 to M8069 with the error codes.

For example, when the error of error code (100) has occurred, refer to the explanation of M8060 and take the corrective action.

## 9.2 Error Code and Error Message List

### (1) Error messages displayed before execution of monitoring

Error Message	Definition	Action
Check communication line. (Cable, driver, module)	The cable, installed communication driver or communication module is faulty.	1. Check for any disconnected cable or improperly fitted communication module. 2. Check the installed communication driver.
Check memory data.	Unauthorized combination of OS program versions installed.	Confirm the versions of the OS programs installed.
F-ROM abnormal	The memory board is not mounted correctly.	Check the memory board mounting status and mounting screw tightening status.

### (2) Error codes and messages displayed during execution of monitoring

The error codes and messages detected by the GOT are indicated below.

Error Code	Error Message	Definition	Action
303	Too many monitor points specified	The number of objects set to the screen to be displayed is too many to reserve the work area of the system	Reduce the number of objects
304	Too many trigger points specified		
305	Too many print-out points specified		
306	No monitor data	Screen data has not been downloaded to the built-in memory	Download the screen data to the built-in memory
307	No monitor device setting	Object monitoring devices not determined	Determine object monitoring devices
308	Specified comment not found or outside range	The comment number set for comment display does not exist or the comment file does not exist	Create the comment file and download it to the GOT
309	Device read error	Device data read caused an error	Correct device
310	Specified monitor data not found or outside range	(1) The specified base screen/window screen does not exist in the project data. (2) The specified base screen/window screen is outside the permissible range.	(1) Specify the existing base screen/window screen. (2) Specify the existing base screen/window screen.
311	More than 1024 alarms in alarm history	The alarms in the history has exceeded the largest number of points (1024 points) which the alarm history display function can monitor	Reduce the alarms in the alarm history (Remove the history recovered)
312	The collected time has exceeded upper limit	The collected time exceeded the upper limit when the following setting had been made for the scattered chart. "Store memory" "Accumulate/Average"	1. Establish "Clear trigger" set for the scattered chart. 2. Set "Operation at frequency over time" of the scattered chart for "Initialize and continue".
315	Device write error	Data write to device caused an error	Correct device
316	Operation result value cannot be displayed/entered	The data operation result has exceeded the range which can be represented by the device type	Reconsider the data operation formula so that the operation result does not exceed the range which can be represented by the device type
320	Specified part not found or outside range	The part number set for part display does not exist.	Confirm the part number specified for the part display in the screen data

Error Code	Error Message	Definition	Action
321	Unauthorized station number specified for monitor device	The station number specified as a monitor destination does not exist or is not the station to be monitored	Confirm the monitor destination station number in the screen data
322	Specified device outside range	The device number to be monitored is outside the permissible range of the corresponding PLC CPU	Set the monitored PLC CPU and parameters to set the device in the monitorable range
323	Specified file register outside range		
324	AD51H-dedicated device used without AD51H	The AD51H-dedicated device was monitored in the system which does not use the AD51H	Incorporate the AD51H into the system or stop monitoring of the AD51H-dedicated device
325	Specified special module not loaded	The specified special module is not loaded	Check the loading status of the specified special module
330	PC card capacity short	The PC card does not have enough capacity	Check the capacity
331	PC card not loaded or memory card access switch OFF	The PC card is not loaded or the memory card access switch is OFF	1. Load the PC card 2. Turn ON the access switch
332	Format error	The PC card is not formatted	Format the PC card
333	PC card write-protected to disable write	The PC card is write-protected	Make the PC card write-enabled
334	PC card fault	PC card failure	Change the PC card
335	PC card battery voltage low	The battery voltage of the PC card is low	Change the battery of the PC card
340	Printer in error or power off	The printer is faulty or its power is not on	1. Check the printer 2. The Printer switch it on
341	Printer fault		
342	The fuse of KBF module was blown	A fault occurred in the external I/O interface module.	1. If external power (24VDC) is not supplied, supply external power. 2. If external power is supplied, change the external I/O interface module.
343	KBF module status is abnormal	The external I/O interface module is not mounted properly.	Mount the external I/O interface module properly.
345	BCD/BIN conversion error	It has been attempted to display/enter a value that cannot be BCD/BIN converted	1. Change the device data to be displayed into a BCD value 2. Enter the value of 4-digit integer
350	RS-232C communication error	The cable used to connect the GOT and personal computer is faulty	1. Check for an unplugged communication cable connector 2. check the cables used
351	Recipe file abnormal	Recipe file data are not normal	1. Check recipe file data in PC card 2. Start GOT after deleting recipe file in PC card
352	Recipe file generation error	Recipe file generation failed	Start GOT after loading PC card
353	Recipe file write disabled	Data write to recipe file failed	1. Check write protect of PC card 2. Check PC card capacity 3. Do not unload PC card during recipe operation
354	Error during recipe file write	Error occurred during recipe file write	Do not unload PC card during recipe operation
355	Error during recipe file read	Error occurred during recipe file read	1. Do not unload PC card during recipe operation 2. Check recipe file data (device values) in PC card

Error Code	Error Message	Definition	Action
356	File system error occurred in the PLC	When the file register name is designated and then the recipe function is operated, an error occurs in the designated file register.	<ol style="list-style-type: none"> <li>1. Check the file register name, and then operate the recipe function again.</li> <li>2. Apply Format PLC memory to the designated PLC drive with the GX Developer, and then operate the recipe function again.</li> </ol>
357	The specified drive of PLC is abnormal	When the file register name is designated and then the recipe function is operated, there is a fault in the PLC drive.	<ol style="list-style-type: none"> <li>1. Check the designated PLC drive, and then operate the recipe function again.</li> <li>2. Apply Format PLC memory to the designated PLC drive with the GX Developer, and then operate the recipe function again.</li> </ol>
358	File of PLC access failure	When the file register name is designated and then the recipe function is operated, the PLC file register could not be accessed.	<ol style="list-style-type: none"> <li>1. Check the designated PLC drive/ file register name, and then operate the recipe function again (If drive 0 was designated, change to a different drive, and then operate the recipe function again).</li> <li>2. Check whether the memory card is write-protected, and then operate the recipe function again.</li> </ol>
359	Processing is from another peripheral device	When the file register name is designated and then the recipe function is operated, other peripheral devices begin processing for the file register.	Wait until the peripheral devices finish operating, and then operate the recipe function again.
360	Division error due to divisor of 0	Divisor 0 occurred in the data operation formula	Reconsider the data operation formula to avoid the divisor of 0
370	Contradiction in magnitude relationship of upper and lower limit values	Upper and lower limit values have been set as [upper limit $\leq$ lower limit]	Check the upper and lower limit value setting and correct them to be [upper limit $\geq$ lower limit]
402	Communication time-out	Time-out error occurred during communication	<ol style="list-style-type: none"> <li>1. Check for any disconnected cable or improperly fitted communication board/communication module</li> <li>2. This may occur if the programmable logic controller load is increased while accessing another station. In this case, move the other station's data to the local station's programmable logic controller, and monitor with the local station.</li> <li>3. If the sequence scan is long, insert a COM command.</li> </ol>
403	SIO request status error	At the time of receive during RS-422/RS-232C communication, any of overrun error, parity bit error and framing error occurred.	Check the cable connection status, the communication board/communication module mounting status, the PLC status, and the communication link transmission speed.
406	Specified station doesn't access for out of range	<ol style="list-style-type: none"> <li>(1) The station number specified for CC-Link connection (via G4) is other than that of the master/local station.</li> <li>(2) Access was made to the CPU other than the QCPU.</li> </ol>	Check the station number of the monitor screen data.
407	Other network accessed by MNET10 module	Access was made to the other network at the time of MELSECNET connection (network system)	Check the network number in the screen data to avoid access to the other network
421	The specification of E71 cannot be written	The Ethernet module on the PLC side has been set for write disable.	Set the PLC side Ethernet module for write enable.
422	It is not communicate between the CPU and E71	The CPU is faulty or communication cannot be made between the CPU and PLC side Ethernet module.	Check the CPU for any fault using GX Developer or like. (Check the buffer memory.)

Error Code	Error Message	Definition	Action
423	Information is insufficient in network table	The station number set as the screen data does not exist in the Ethernet setting of GT Designer/ GT Designer 2.	Add the station number set as the screen data to the Ethernet setting of GT Designer/GT Designer 2. (Use the station number of the PLC side Ethernet module set in the parameter setting of GX Developer.)
424	The same bureau is set by GOT and monitor data.	The station number set on the utility screen of the GOT is the same as the station number set in the Ethernet setting of GT Designer/GT Designer 2 (station number of the PLC side Ethernet module) or the station number set as the screen data.	Check the following data and do not use the same station number. 1. Check the station number of the GOT on the utility screen of the GOT. 2. Check the station number set as the screen data. 3. Check the station number set in the Ethernet setting. (Use the station number of the PLC side Ethernet module set in the parameter setting of GX Developer.)
448	Devices outside file register and other ranges included	Devices specified are outside file register or buffer memory range of QnACPU	Set PLC file registers. Also correct monitor devices
470	Communication destination faulty	During monitoring of the other station via MELSECNET/10, a fault occurred in the corresponding communication station	Check whether the corresponding communication station has been set correctly in the management station (reconsider the parameters, switch setting, etc.)
499	CPU communication error	Other communication error	Check for any disconnected cable or improperly fitted communication module

## 9.3 Precautions for Installation of ROM\_BIOS

### (1) About ROM\_BIOS

ROM\_BIOS is available in two types: for large-sized GOTs (A985GOT(-V), A975GOT, A970GOT, A960GOT) and for medium-sized GOTs (A950GOT, A951GOT, A953GOT, A956GOT) and wide-sized GOT (A956WGOT).

Note the following when installing ROM\_BIOS in the A950GOT, A951GOT, A953GOT, A956GOT or A956WGOT.

- Do not install ROM\_BIOS designed for large-sized GOT in any of the DoA950GOT, A951GOT, A953GOT, A956GOT and A956WGOT.
- Do not install ROM\_BIOS designated for large-sized GOTs or medium-sized GOTs in the A956WGOT.
- Do not install ROM\_BIOS of a version earlier than the version of ROM\_BIOS installed in the GOT.

Refer to the following manual for the ROM\_BIOS installation method.

- When GT Designer is used: GT Works Version □ /GT Designer Version □ Reference Manual
- When GT Designer2 is used: GT Works2 Version □ /GT Designer2 Version □ Operating Manual



Check the rating plate on the back of the GOT to confirm the version of ROM\_BIOS factory-installed in the GOT.

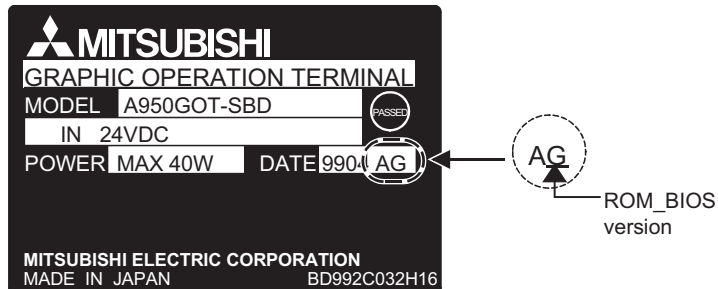

(2) About the messages displayed

- (a) The GOT will display the following messages if you attempt to install ROM\_BIOS that is not compatible with the GOT to be used.

Should the following messages appear due to wrong operation you performed, there will be no problems since installation is not executed and ROM\_BIOS is not rewritten.

```

osが不正です
Wrong operating system
    
```

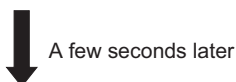

```

OSをインストールして下さい
通信ドライバをインストールして下さい

Please install operating system
Please install com. driver
    
```

If the above messages have appeared, hold the above screen in that status and install the standard monitor OS, communication driver and so on.

**Point** 

The following message will also appear when you power on your GOT for the first time.

In this case, the message does not relate to the installation of ROM\_BIOS.

Unless you install the standard monitor OS, the following message will appear whenever you start the GOT.

```

OSをインストールして下さい
通信ドライバをインストールして下さい

Please install operating system
Please install com. driver
    
```

- (b) The GOT will display the following messages if you attempt to install ROM\_BIOS of a version earlier than the version of ROM\_BIOS installed in the GOT.  
Should the following messages appear due to wrong operation you performed, there will be no problems since installation is not executed and ROM\_BIOS is not rewritten.

ROM\_BIOS setup Ver1. 1. 0 [B]  
△ 注意：電源を切らないで下さい。  
リセットボタンを押さないで下さい。  
Don't turn off the power supply  
Don't push the reset button.  
ROM\_BIOS Not Rewritable.  
GOT stopped  
Please install operating system.

If the above messages have appeared, hold the above screen in that status and install the standard monitor OS, communication driver and so on.



## 9.4 Troubleshooting in bus connection

If a cause cannot be located by the troubleshooting procedures specified in section 9.2 when the GOT is bus-connected to the PLC CPU, troubleshoot the cause as follows.

### 9.4.1 Locating error positions

(1) How to locate error positions:

(a) Use of peripheral devices

Using the peripheral devices such as GPP, check what type of the error occurs on the PLC CPU and, based on the error message on the PLC CPU and the check points (See item (2) below), check each module and cable for installation and earthing statuses.

(b) Error timing

Check the timing of errors.

1) An error occurs when the power is turned on or immediately after the PLC is reset:

The error may be detected by the initial processing of the PLC CPU.

In this case, because the faulty module may not be identified, use only an END instruction for the sequence program and remove the modules one by one until the error does not occur.

When the error is eliminated after a specific module has been removed, the module may be causing the error.

2) An error occurs after a specific operation or several seconds:

The error may occur in the sequence program. Check the error step where the error may occur and the sequence program in that step.

The sequence program can be diagnosed throughout by merely using an END instruction for the sequence program.

3) An error occurs when a specific device operates:

The mis-operation may be caused by noise.

Check that any signal line such as bus cable is not laid out too close to the operating device. If the line is too close to the device, separate the line 100 mm or more from the device.

(c) Locating the module where an error occurs:

Based on the PLC CPU error codes and special register information (See item (2)), locate a specific module where an error occurs.

By the method stated above, correct the sequence program or replace the faulty module with a new one, and check whether the error occurs.

If the error continues to occur, it may have another cause.

Referring to section 9.4.2, locate the error position further.

(2) Error messages appearing due to faulty ACPU bus connection and measure against errors

Error Code	Error Messages	Check Timing	Cause and check point		
			Error detail	Remedy	Corresponding CPU
22	WDT ERR.	When an End instruction is executed	(1) The scanning time exceeds the calculation congestion monitoring time. (2) The scanning time may be extended by waiting for a response from an SP module that is down, and errors may occur simultaneously.	(1) Use the error history to check whether simultaneous occurrence errors are present. (2) Refer to the SP module down check points.	ACPU
31	UNIT VERIFY ERR.	When an End instruction is executed	The information stored in the cards of the module installed in the base module and the communication module of the GOT is different from that read at the initial time. (If an error occurs on a module (vacant) other than that installed in the base module, the mis-operation may be caused by noise.)	Check the faulty module at special resistors D9116 to D9123. (1) Check that the module and the cables are connected correctly. (2) Check that the PLC and the GOT are earthed correctly.	
40	CONTROL_BUS ERR.	During execution of FROM/TO instruction set	When the FROM/TO instruction is executed, an imprecise response is returned from the special function module (including the GOT).	Check the faulty module from the error step. (1) Check that the module and the cables are connected correctly. (2) Replace the faulty module with a new one. (3) Check that the PLC and the GOT are earthed correctly.	
		At CPU power ON/ At reset	At the time of initial communication, an imprecise response is returned from the special function module (including the GOT).	(1) Check that the module and the cables are connected correctly. (2) Because a faulty module cannot be located, remove the modules one by one until no CONTROL_BUS ERR. message appears to indicate the module where the error occurs. (Because the modules are removed, SP. UNIT ERR. message may appear. Stop transmitting the FROM/TO instruction to the applicable module.)	
41	SP. UNIT DOWN	During execution of FROM/TO instruction set	The special function module was accessed during the execution of a FROM/TO instruction set, but there was no response.	Check the faulty module from the error step. (1) Check that the module and the cables are connected correctly. (2) Replace the faulty module with a new one. (3) Check that the PLC and the GOT are earthed correctly.	
		At CPU power ON/ At reset	At the time of initial communication, a response is not returned from the special function module (including the GOT).	(1) Check that the module and the cables are connected correctly. (2) Replace the faulty module with a new one. (3) Check that the PLC and the GOT are earthed correctly.	
43	I/O INT ERR.	During interrupt	An imprecise interrupt occurs to the PLC CPU.	(1) Check the number of installed modules. (2) Check the number of extension stages and the I/O slot numbers.	
44	SP. UNIT LAY ERR.	At CPU power ON/ At reset	Too many modules are installed (see the PLC CPU specification).	(1) Review the sequence program. (2) Check the number of extension stages and the I/O slot numbers.	
46	SP. UNIT ERR.	During execution of FROM/TO instruction set	The FROM/TO instruction is executed to any module other than the special function module.		

(3) Error messages appearing due to faulty Q/QnACPU bus connection and measure against errors

Error Code	Error Messages	Check Timing	Cause and check point		
			Error detail	Remedy	Corresponding CPU
1310	I/O INT ERROR.	During interrupt	An imprecise interrupt occurs to the PLC CPU.		QCPU QnACPU
1401	SP. UNIT DOWN	At CPU power ON/ At reset/When intelligent function module is accessed.	There was no response from the intelligent function module during initial communications stage. • The size of the buffer memory of the intelligent function module is abnormal.	(1) Check that the module and the cables are connected correctly. (2) Replace the faulty module and the cables with new ones. (3) Check that the PLC and the GOT are earthed correctly. (4) Check the number of extension stages and the I/O slot numbers.	QCPU
		At CPU power ON/ At reset	At the time of initial communication, a response is not returned from the special function module (including the GOT).		QnACPU
1402	When an intelligent function module access instruction is executed.	The intelligent function module was accessed in the program, but there was no response.	QCPU		
	During execution of FROM/TO instruction set	The special function module was accessed during the execution of a FROM/TO instruction set, but there was no response.	QnACPU		
1403	When an End instruction is executed	There was no response from the intelligent function module when the END instruction is executed. • An error is detected at the intelligent function module.	QCPU		
1411	CONTROL_BUS ERR.	At CPU power ON	At the time of initial communication, an imprecise response is returned from the special function module (including the GOT).	(1) Check that the module and the cables are connected correctly. (2) Because a faulty module cannot be located, remove the modules one by one until no CONTROL_BUS ERR. message appears to indicate the module where the error occurs. (Because the modules are removed, SP. UNIT ERR. message may appear. Stop transmitting the FROM/TO instruction to the applicable module.)	QCPU QnACPU
1412		During execution of FROM/TO instruction set	When the FROM/TO instruction is executed, an imprecise response is returned from the special function module (including the GOT).	Check the faulty module from the error step. (1) Check that the module and the cables are connected correctly. (2) Replace the faulty module with a new one. (3) Check that the PLC and the GOT are earthed correctly.	
2000	UNIT VERIFY ERR.	When an End instruction is executed	The information stored in the cards of the module installed in the base module and the communication module of the GOT is different from that read at the initial time. (If an error occurs on a module (vacant) other than that installed in the base module, the mis-operation may be caused by noise.)	Check the faulty module at special registers SD1400 to SD1431. (1) Check that the module and the cables are connected correctly. (2) Check that the PLC and the GOT are earthed correctly.	QCPU QnACPU

Error Code	Error Messages	Check Timing	Cause and check point		
			Error detail	Remedy	Corresponding CPU
2100	SP. UNIT LAY ERR.	At CPU power ON/ At reset	(1) In the parameter I/O allocation settings, an intelligent function module was allocated to a location reserved for an I/O module. Or, the opposite has happened. (2) In the parameter I/O allocation settings, a module other than CPU (or nothing) was allocated to a location reserved for a CPU module. Or, the opposite has happened. (3) A general-purpose switch was set to the module with no general-purpose switches.	(1) Reset the parameter I/O allocation according to the status of installation of the intelligent function module. (2) Reset the parameter I/O allocation according to the status of installation of the CPU module. (3) Reset the general-purpose switch settings. (4) Check the number of extension stages and the I/O slot numbers.	QCPU
			In parameter I/O allocation settings, a special function module was allocated to a location reserved for an I/O module. Or, the opposite has happened.	(1) Reset the parameter I/O allocation setting to conform with the actual status of the special function modules. (2) Check the number of extension stages and the I/O slot numbers.	QnACPU
The modules more than those specified in the PLC CPU specification are installed.			(1) Check the number of installed modules. (2) Check the number of extension stages and the I/O slot numbers.	QCPU QnACPU	
At the MELSENET/MINI auto refresh parameter settings, the module allocation that was set is different from the actual module models at the station numbers in the link system.			Reset the parameter MELSENET/MINI auto refresh unit module allocation setting so that it conforms to the station number of the module that is actually linked.	QnACPU	
There are too many special function modules that can use dedicated instructions allocated (number of modules installed).			Reduce the number of special function modules installed.		
(1) 5 or more QJ71LP21/BR11 have been installed. (2) 5 or more QJ71E71 (-B2) have been installed. (3) Identical network numbers or station numbers exist in the MELSENET/10 network system.			(1) Keep the number to 4 or fewer. (2) Keep the number to 4 or fewer. (3) Check the network numbers and station numbers.	QCPU	
Head X/Y set at the parameter I/O allocation settings is also the head X/Y for some other module.			(1) Reset the parameter I/O allocation setting to conform with the actual status of the special function modules. (2) Check the number of extension stages and the I/O slot numbers.	QCPU QnACPU	
(1) Network module A1SJ71LP21, A1SJ71BR11, A1SJ71AP21 * , A1SJ71AR21, or A1SJ71AT2 * B dedicated for the A2USCPU has been installed. (2) Network module A1SJ71QLP21 or A1SJ71QBR11 dedicated for the Q2AS has been installed. Change the network module to QJ71LP21 or QJ71BR11.			Change network module to QJ71LP21 or QJ71BR11.	QCPU	
AJ71LP21 or AJ71BR11 for use with the AnUCPU network module has been installed.			Change network module to AJ71QLP21 or AJ71QBR11.	QnACPU	
2109			The control system and standby system module configurations are different when a redundant system is in the backup mode.	Check the module configuration of the standby system.	Q4ARCPU

Error Code	Error Messages	Check Timing	Cause and check point		
			Error detail	Remedy	Corresponding CPU
2110	SP. UNIT ERROR.	When instruction executed	The FROM/TO instruction is executed to any module other than the special function module.	(1) Review the sequence program. (2) Replace the faulty module with a new one.	QCPU QnACPU
2111			The location designated by link direct device (J□/□) is not a network module.		
2112		When instruction executed/ STOP → RUN	(1) The location designated by a special function module dedicated instruction is not a special function module. (2) Alternatively, it is not the relevant special function module.	Review the sequence program.	
2113			No special function module data for simulation purposes has been set in the simulation data.	Read error individual information, then check and edit the special function module simulation data that corresponds to the numerical value there (program error location).	
2120			At CPU power ON/ At reset	The location of Q□B and QA1S□B is improper.	
2122	QA1S□B is installed to the basic base unit.	Install Q□B as the basic base unit.			
2124	(1) A module is installed at 65th or later slot. (2) A module is installed at the slot later than the number of slots specified with base allocation setting. (3) A module is installed at the I/O points later than the 4,096th point. (4) A module installed at the 4,096th point occupies later points.	(1) Remove the module installed at 65th or later slot. (2) Remove the module installed at the slot later than the number of slots specified with base allocation setting. (3) Remove the module installed at the I/O points later than the 4,096th point. (4) Change the last module to a module which does not exceed the 4,096th point.			
2125	(1) A module which the QCPU cannot recognize has been installed. (2) There was no response from the intelligent function module.	(1) Install a module which can be used with the QCPU. (2) Replace the faulty module with a new one.			
5000	WDT ERROR.	Always	Program scan time for initial execution type program goes over the initial execution WDT time set in the parameter PC RAS settings.	Read the error individual information at a peripheral device, check the numerical value (time) there, and shorten scan time if necessary.	QCPU QnACPU
5001			Program scan time goes over the WDT value set in the parameter PC RAS settings.		

## 9.4.2 Further locating error positions

If the function of the PLC cannot be recovered even when the module on which an error occurs is replaced with a new one, the error may be caused by the effect from another module.

Disconnect the extension cables and bus connection cables in order from the modules starting from the module located furthest from the operating position in the system, and check for the status of occurrence of the error each time the cables are disconnected until the error does not occur.

The module or extension cables/bus-connection cables disconnected immediately before the error does not occur are considered to cause the error.

Examples of the ways of further locating error positions are shown below.

### Example 1:

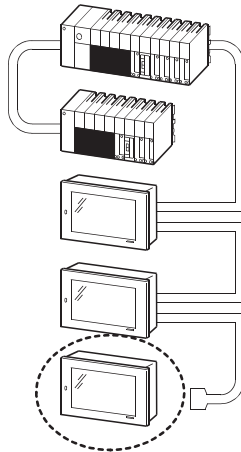
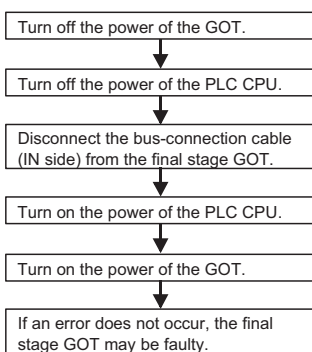

### Example 2:

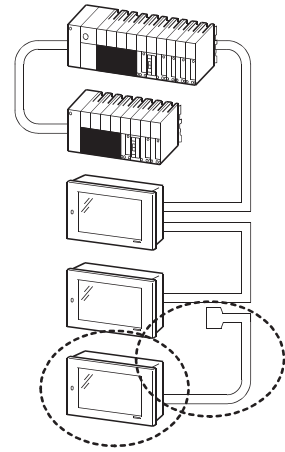
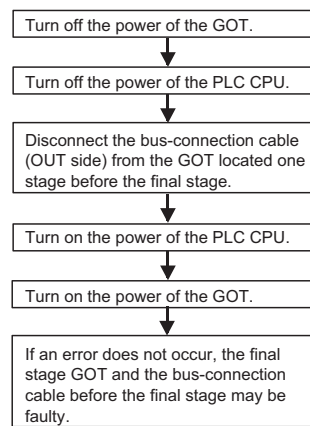

Repeat the examples 1 and 2 above to locate error positions.



- When disconnecting the extension base units in order, use only an END instruction for the sequence program, and any error resulting from the sequence program will not occur, and the status of occurrence of errors will be obtained easily.
- When the frequency of occurrence of an error is low, check the error by taking a rather long time with the modules disconnected.
- The checks stated above are effective to locate a noise invading route when the mis-operation is caused by noise.

### 9.4.3 Specific example of troubleshooting

An example of troubleshooting the system which is used when an error occurs on the PLC CPU is shown below.

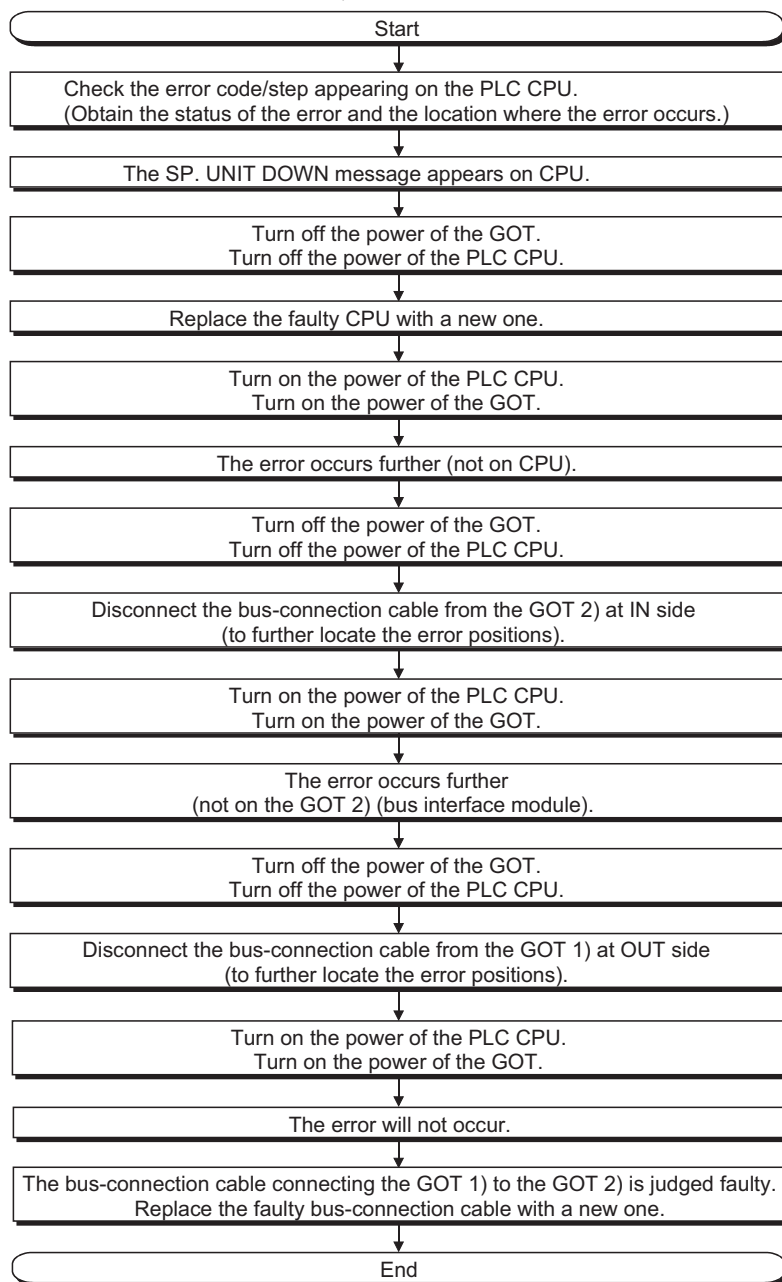
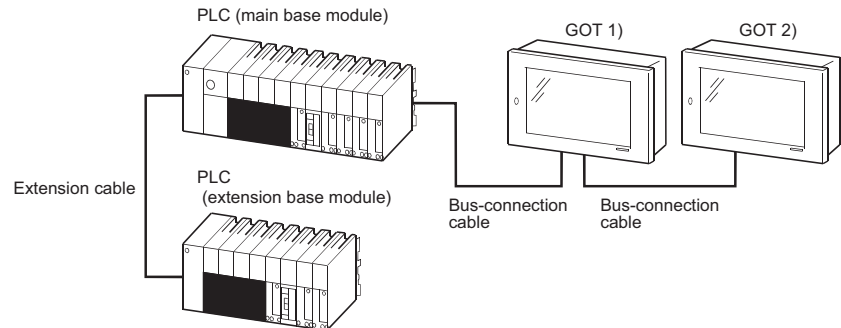

## 9.5 Troubleshooting for monitoring

The following describes the corrective action when the GOT monitoring screen is blank.

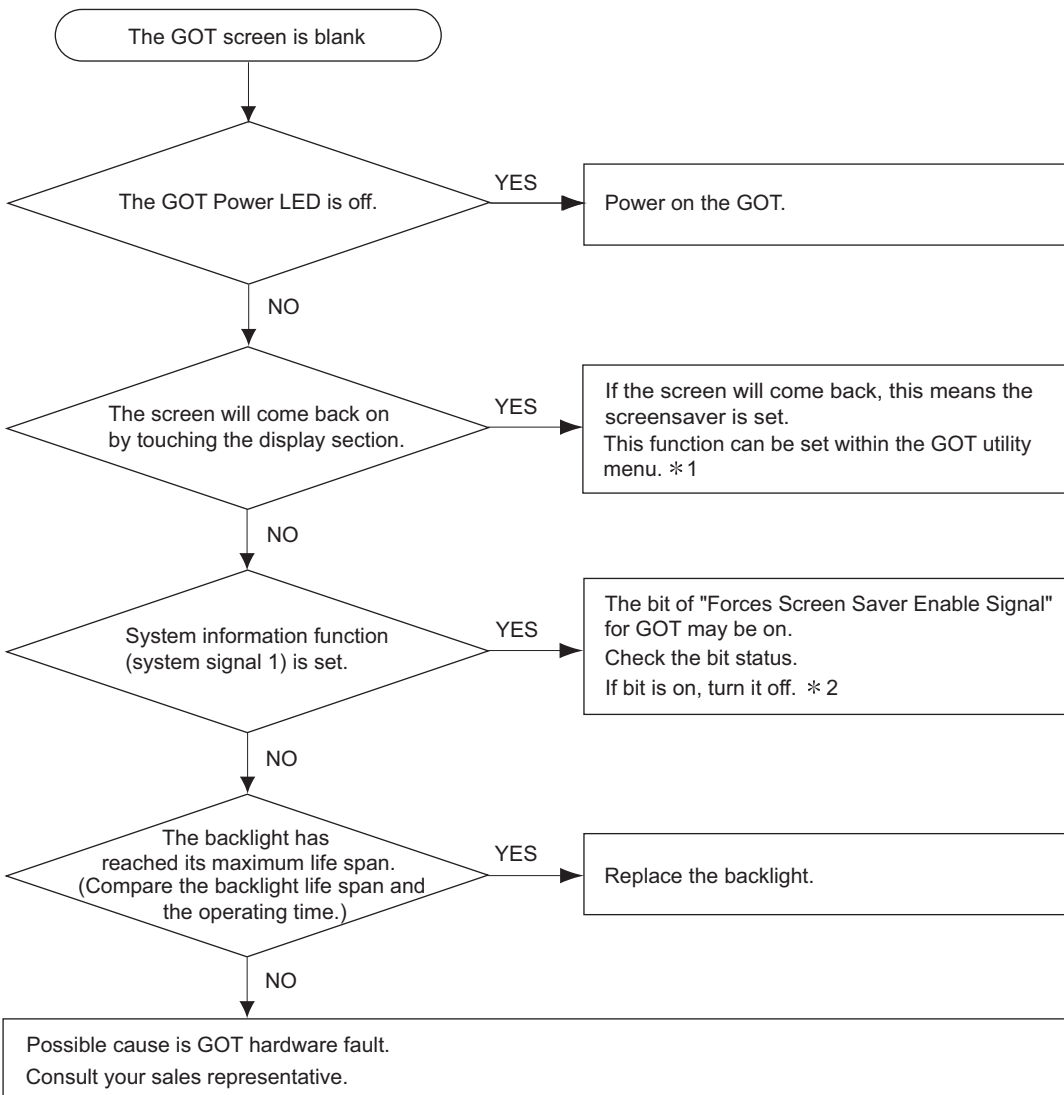

\*1 Refer to GOT-A900 Series Operating Manual (Extended \_ Option Functions Manual), for utility menu.

\*2 Refer to the following manual for details of the forced screen save signal.

- When GT Designer is used: Help function of GT Designer
- When GT Designer2 is used: GT Designer2 Version □ Reference Manual



# APPENDICES

## Appendix.1 Outline Dimension Drawings

1) Outline dimension drawing of the A95\*GOT

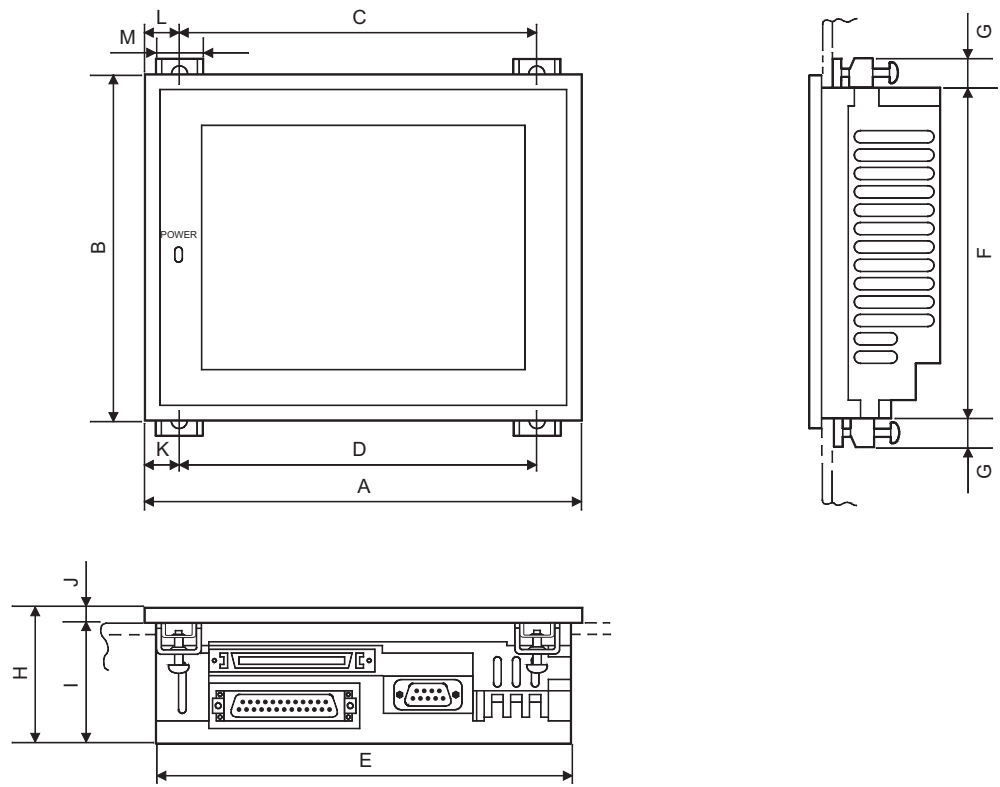

Unit (mm (inch))

Type code	A	B	C	D	E	F	G	H	I	J	K	L	M
A95*GOT-(Q)													
TBD(-M3)	164.5	136	125.5	130.1	155.5	123	10	65	59	6	14.9	19.5	15.4
A95*GOT-(Q)	(6.48)	(5.36)	(4.94)	(5.13)	(6.13)	(4.85)	(0.39)	(2.56)	(2.32)	(0.24)	(0.59)	(0.77)	(0.61)
SBD(-M3)-B													
A95*GOT-(Q)	164.5	136	125.5	130.1	155.5	123	10	57	51	6	14.9	19.5	15.4
SBD/LBD(-M3)	(6.48)	(5.36)	(4.94)	(5.13)	(6.13)	(4.85)	(0.39)	(2.25)	(2.01)	(0.24)	(0.59)	(0.77)	(0.61)

2) Outline dimension drawing of the A956WGOT

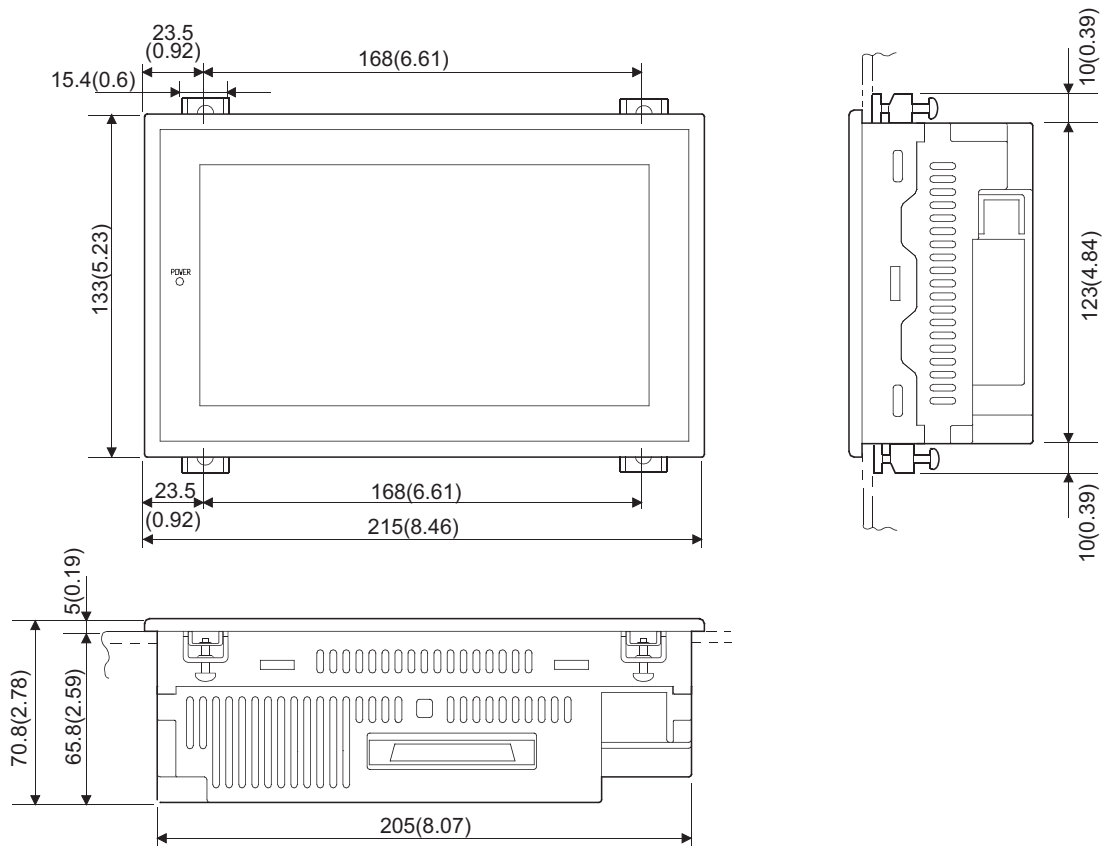

# Appendix.2 Depth at the Time of Communication Module Loading (A956GOT/A956WGOT Only)

(1) When A9GT-50WQBUISS is used

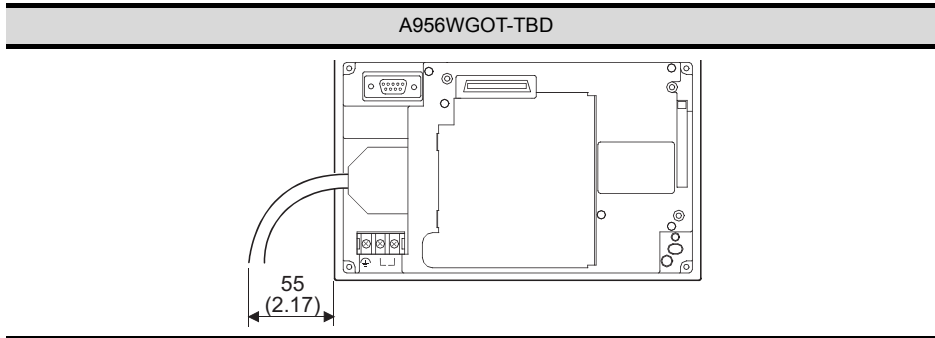

(2) When A9GT-50WBUISS is used

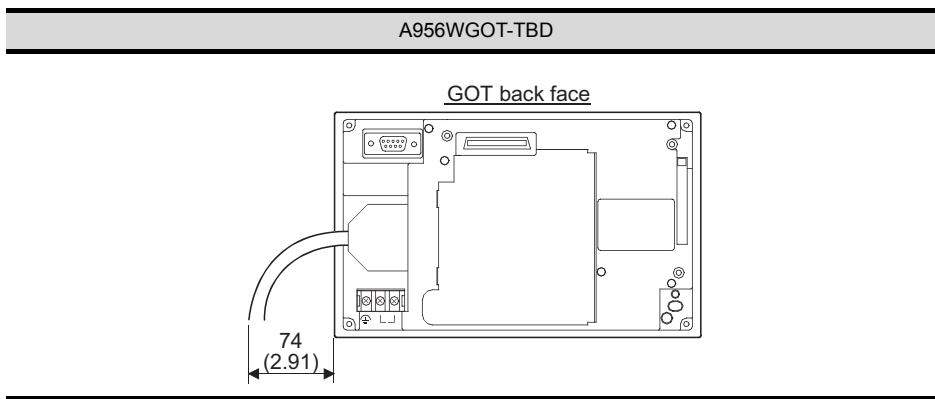

(3) When A9GT-50WRS2/A9GT-50WRS4 is used

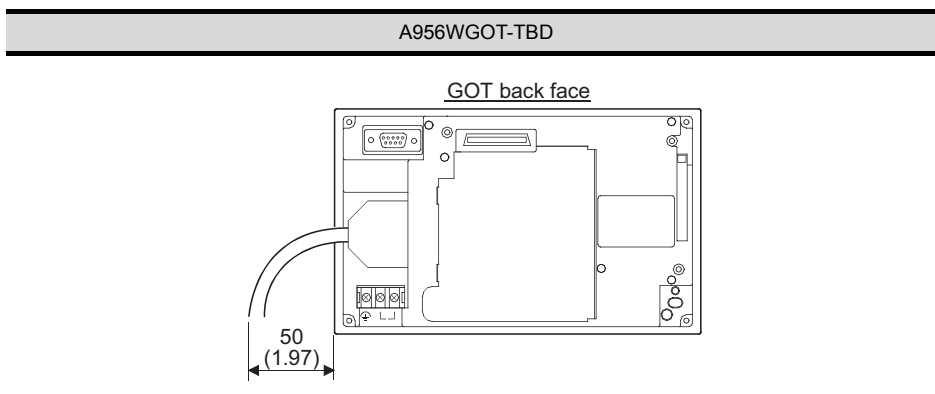

(4) When A9GT-QBUS2SU/A9GT-BUSSU/A9GT-BUS2SU is used

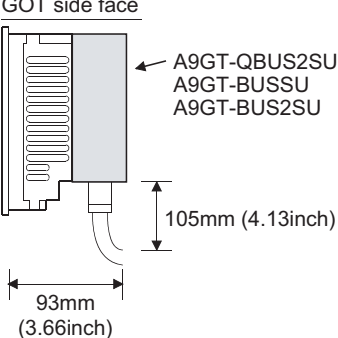
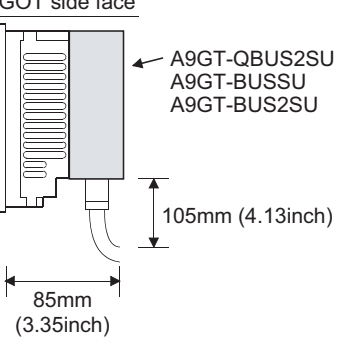
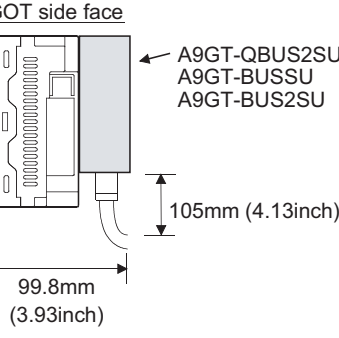
A956GOT-TBD(-M3)/ A956GOT-SBD(-M3)-B	A956GOT-SBD/LBD(-M3)	A956WGOT-TBD
<p>GOT side face</p>  <p>A9GT-QBUS2SU A9GT-BUSSU A9GT-BUS2SU</p> <p>105mm (4.13inch)</p> <p>93mm (3.66inch)</p>	<p>GOT side face</p>  <p>A9GT-QBUS2SU A9GT-BUSSU A9GT-BUS2SU</p> <p>105mm (4.13inch)</p> <p>85mm (3.35inch)</p>	<p>GOT side face</p>  <p>A9GT-QBUS2SU A9GT-BUSSU A9GT-BUS2SU</p> <p>105mm (4.13inch)</p> <p>99.8mm (3.93inch)</p>

(5) When A7GT-BUSS/A7GT-BUS2S is used

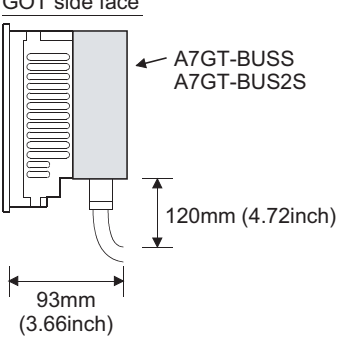
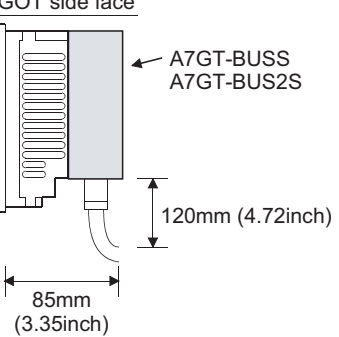
A956GOT-TBD(-M3)/ A956GOT-SBD(-M3)-B	A956GOT-SBD/LBD(-M3)
<p>GOT side face</p>  <p>A7GT-BUSS A7GT-BUS2S</p> <p>120mm (4.72inch)</p> <p>93mm (3.66inch)</p>	<p>GOT side face</p>  <p>A7GT-BUSS A7GT-BUS2S</p> <p>120mm (4.72inch)</p> <p>85mm (3.35inch)</p>

(6) When A9GT-QJ71LP23/A7GT-J71AP23/A7GT-J71LP23 is used

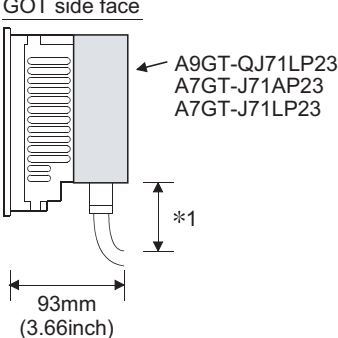
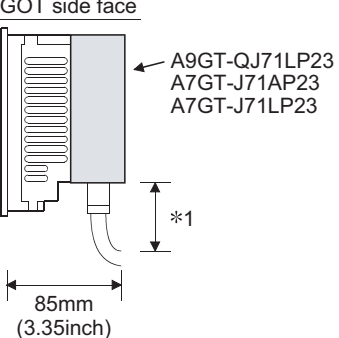
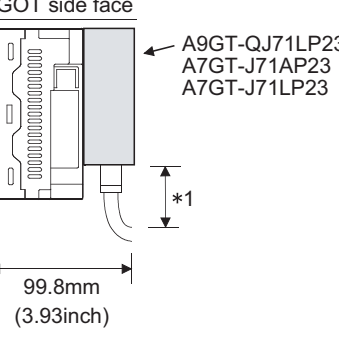
A956GOT-TBD(-M3)/ A956GOT-SBD(-M3)-B	A956GOT-SBD/LBD(-M3)	A956WGOT-TBD
<p>GOT side face</p>  <p>A9GT-QJ71LP23 A7GT-J71AP23 A7GT-J71LP23</p> <p>*1</p> <p>93mm (3.66inch)</p>	<p>GOT side face</p>  <p>A9GT-QJ71LP23 A7GT-J71AP23 A7GT-J71LP23</p> <p>*1</p> <p>85mm (3.35inch)</p>	<p>GOT side face</p>  <p>A9GT-QJ71LP23 A7GT-J71AP23 A7GT-J71LP23</p> <p>*1</p> <p>99.8mm (3.93inch)</p>

\*1 Determined by the optical fiber cable and connector used.

(7) When A9GT-QJ71BR13/A7GT-J71AR23/A7GT-J71BR13 is used

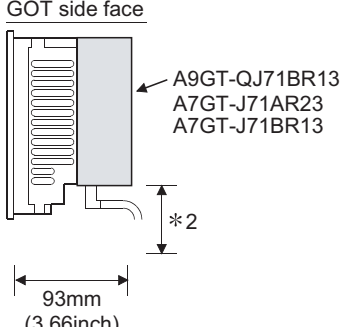
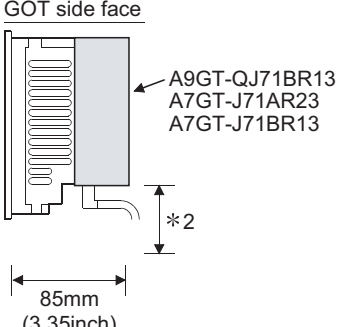
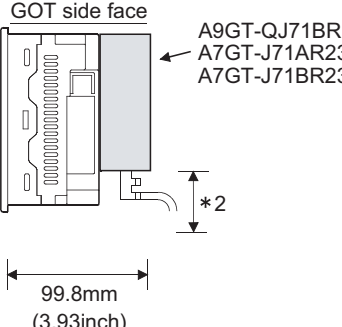
A956GOT-TBD(-M3)/ A956GOT-SBD(-M3)-B	A956GOT-SBD/LBD(-M3)	A956WGOT-TBD
<p>GOT side face</p>  <p>A9GT-QJ71BR13 A7GT-J71AR23 A7GT-J71BR13</p> <p>93mm (3.66inch)</p>	<p>GOT side face</p>  <p>A9GT-QJ71BR13 A7GT-J71AR23 A7GT-J71BR13</p> <p>85mm (3.35inch)</p>	<p>GOT side face</p>  <p>A9GT-QJ71BR13 A7GT-J71AR23 A7GT-J71BR13</p> <p>99.8mm (3.93inch)</p>

\*2 Determined by the coaxial cable and connector used.

(8) When A7GT-J71AT23B is used

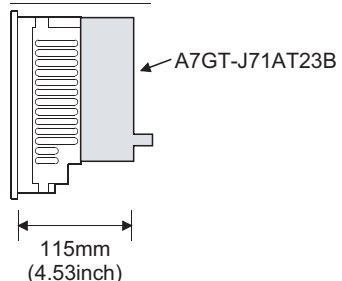
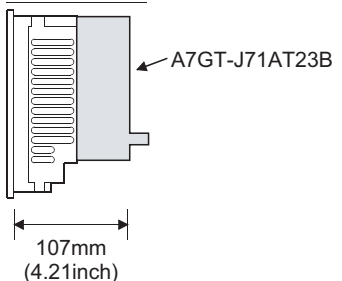
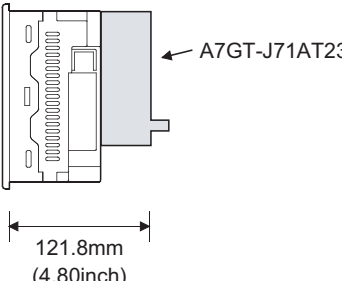
A956GOT-TBD(-M3)/ A956GOT-SBD(-M3)-B	A956GOT-SBD/LBD(-M3)	A956WGOT-TBD
<p>GOT side face</p>  <p>A7GT-J71AT23B</p> <p>115mm (4.53inch)</p>	<p>GOT side face</p>  <p>A7GT-J71AT23B</p> <p>107mm (4.21inch)</p>	<p>GOT side face</p>  <p>A7GT-J71AT23B</p> <p>121.8mm (4.80inch)</p>

(9) When A8GT-J61BT13/A8GT-J61BT15 is used

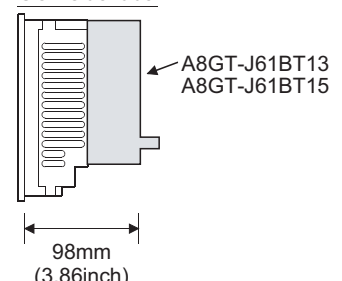
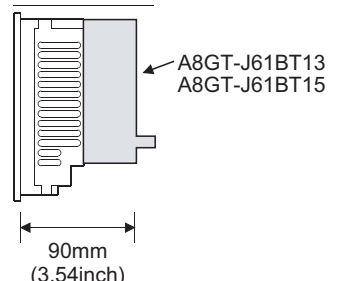
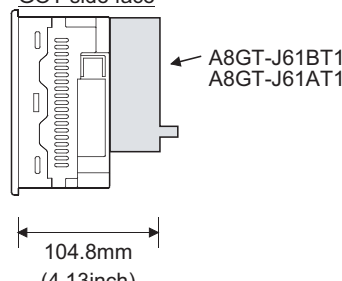
A956GOT-TBD(-M3)/ A956GOT-SBD(-M3)-B	A956GOT-SBD/LBD(-M3)	A956WGOT-TBD
<p>GOT side face</p>  <p>A8GT-J61BT13 A8GT-J61BT15</p> <p>98mm (3.86inch)</p>	<p>GOT side face</p>  <p>A8GT-J61BT13 A8GT-J61BT15</p> <p>90mm (3.54inch)</p>	<p>GOT side face</p>  <p>A8GT-J61BT13 A8GT-J61AT15</p> <p>104.8mm (4.13inch)</p>

(10) When A9GT-J71E71-T is used

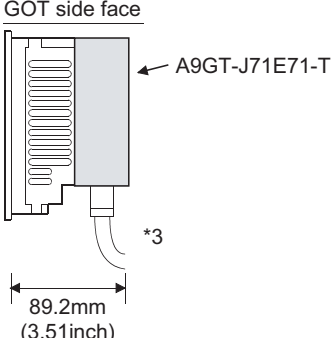
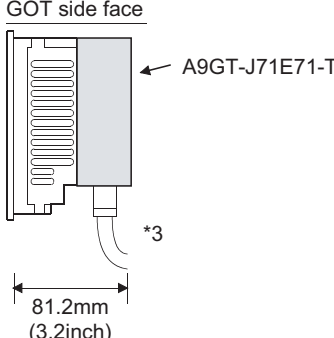
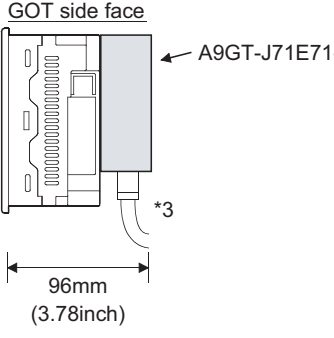
A956GOT-TBD(-M3)/ A956GOT-SBD(-M3)-B	A956GOT-SBD/LBD(-M3)	A956WGOT-TBD
<p>GOT side face</p>  <p>A9GT-J71E71-T</p> <p>89.2mm (3.51inch)</p> <p>*3</p>	<p>GOT side face</p>  <p>A9GT-J71E71-T</p> <p>81.2mm (3.2inch)</p> <p>*3</p>	<p>GOT side face</p>  <p>A9GT-J71E71-T</p> <p>96mm (3.78inch)</p> <p>*3</p>

\*3 The bending radius (R1: guideline value) near the connector should be the cable outline × 4 or more.

(11) When A9GT-50PRF is used

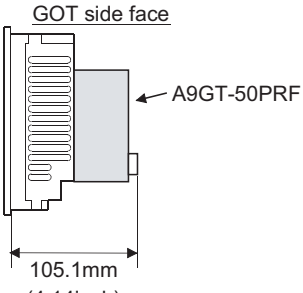
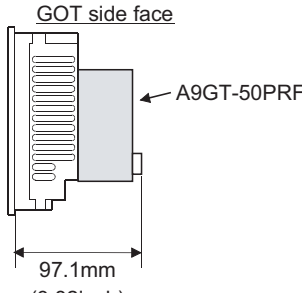
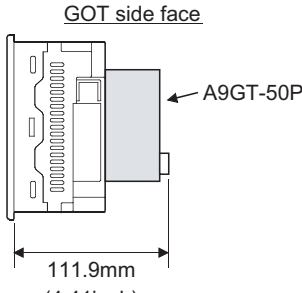
A956GOT-TBD(-M3) / A956GOT-SBD(-M3)-B	A956GOT-SBD/LBD(-M3)	A956WGOT-TBD
<p>GOT side face</p>  <p>A9GT-50PRF</p> <p>105.1mm (4.14inch)</p>	<p>GOT side face</p>  <p>A9GT-50PRF</p> <p>97.1mm (3.82inch)</p>	<p>GOT side face</p>  <p>A9GT-50PRF</p> <p>111.9mm (4.41inch)</p>

(12) When A8GT-50KBF is used

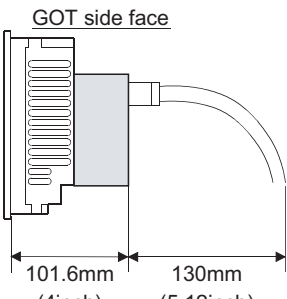
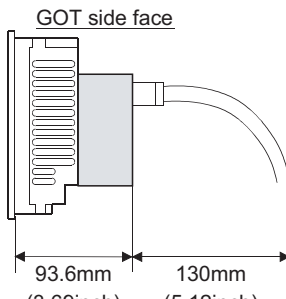
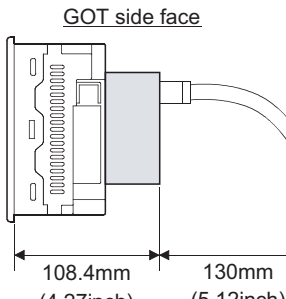
A956GOT-TBD(-M3)/ A956GOT-SBD(-M3)-B	A956GOT-SBD/LBD(-M3)	A956WGOT-TBD
<p>GOT side face</p>  <p>101.6mm (4inch)</p> <p>130mm (5.12inch)</p>	<p>GOT side face</p>  <p>93.6mm (3.69inch)</p> <p>130mm (5.12inch)</p>	<p>GOT side face</p>  <p>108.4mm (4.27inch)</p> <p>130mm (5.12inch)</p>

# Appendix.3 Outline Dimension Drawings of Bus Connection Cables

Type	Cable thickness (mm)	Connector type	
		GOT side	PLC side
A1SC□B	9	Fig. 1	Fig. 1
A8GT-C□BS*1	9	Fig. 6	Fig. 6
A8GT-C□EXSS*1	8	Fig. 1	Fig. 2
A8GT-C□EXSS-1*2	9	Fig. 6	Fig. 6
A8GT-C□NB	8	Fig. 1	Fig. 3
A9GT-QC□BS	10	Fig. 5	Fig. 5
AC□B	17	Fig. 3	Fig. 3
AC□B-R	17	Fig. 4	Fig. 4
QC□B	10	Fig. 5	Fig. 5
A8GT-EXCNB	9	Fig. 7	Fig. 6

\*1 The A8GT-C□EXSS/C□BS cable has a ground cable (1m).

Always connect this ground cable to the control panel or other places.

\*2 The A8GT-C□EXSS-1 is provided as a set of the A8GT-EXCNB and A8GT-C□BS. (Refer to Fig. 8.)

Fig. 1

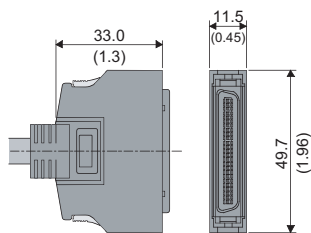

Fig. 2

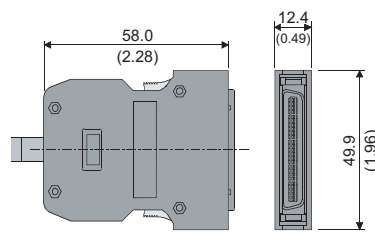

Fig. 3

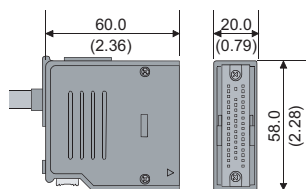

Fig. 4

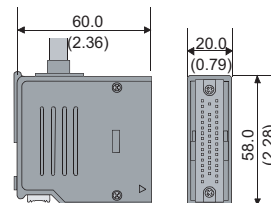

Fig. 5

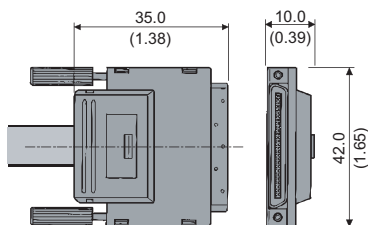

Fig. 6

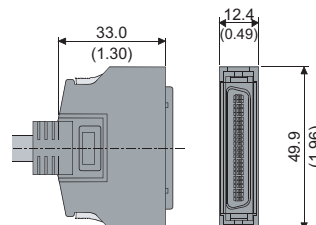

Fig. 7

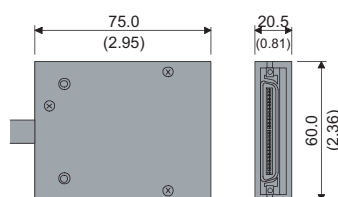
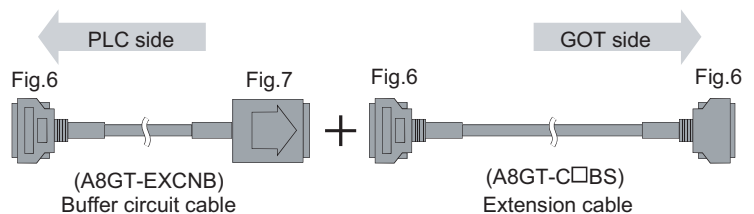

Fig. 8



Unit: mm

# INDEX

[A]	Attachment (A95*GOT only).....	6-29	Protective Sheet .....	6-13	
[B]	Bar Code Reader.....	6-27	[R]	ROUGH PRE-OPERATION PROCEDURE.....	5-1
[C]	Communication Board.....	6-20	[S]	SYSTEM CONFIGURATION	
	Communication Module (A956GOT, A956WGOT Only).....	6-21		Component List .....	2-3
	Compact flash PC card (A956WGOT only).....	6-18		Overall Configuration .....	2-1
[D]	Daily Inspection .....	7-2		System Configuration of the GOT .....	2-3
	Debug Stand.....	6-28		Unusable Conventional Products.....	2-10
	Depth at the Time of Communication Module Loading (A956GOT/A956WGOT Only).....	APP-3	[T]	Troubleshooting in bus connection .....	9-9
[E]	EMC Directive.....	8-1	[W]	Wiring method.....	6-5
	Error Code and Error Message List.....	9-2			
	ERROR CODES AND ERROR MESSAGES.....	9-1			
	External I/O Module .....	6-26			
[H]	How to Change the Backlight for Liquid Crystal ....	7-3			
[I]	Installation method .....	6-3			
[M]	Memory board (A956WGOT only).....	6-14			
	Memory Card Interface Module .....	6-15			
[N]	NAMES OF THE PARTS AND THEIR SETTINGS .....	4-1			
	Notes on Q4ARCPU Duplex System.....	2-11			
[O]	Outline Dimension Drawings .....	APP-1			
	Outline Dimension Drawings of Bus Connection Cables .....	APP-7			
[P]	PC card types .....	6-16			
	PERFORMANCE				
	General Specification .....	3-1			
	Performance Specifications .....	3-2			
	Power Supply Specifications.....	3-8			
	Periodic Inspection .....	7-2			
	Precautions for Installation of ROM_BIOS .....	9-6			
	Printer Interface Module .....	6-24			
	Printer types .....	6-25			





# Warranty

Please confirm the following product warranty details before using this product.

## 1. Gratis Warranty Term and Gratis Warranty Range

If any faults or defects (hereinafter "Failure") found to be the responsibility of Mitsubishi occurs during use of the product within the gratis warranty term, the product shall be repaired at no cost via the sales representative or Mitsubishi Service Company.

However, if repairs are required onsite at domestic or overseas location, expenses to send an engineer will be solely at the customer's discretion. Mitsubishi shall not be held responsible for any re-commissioning, maintenance, or testing on-site that involves replacement of the failed module.

[Gratis Warranty Term]

The gratis warranty term of the product shall be for one year after the date of purchase or delivery to a designated place.

Note that after manufacture and shipment from Mitsubishi, the maximum distribution period shall be six (6) months, and the longest gratis warranty term after manufacturing shall be eighteen (18) months. The gratis warranty term of repair parts shall not exceed the gratis warranty term before repairs.

[Gratis Warranty Range]

- (1) The range shall be limited to normal use within the usage state, usage methods and usage environment, etc., which follow the conditions and precautions, etc., given in the instruction manual, user's manual and caution labels on the product.
- (2) Even within the gratis warranty term, repairs shall be charged for in the following cases.
  1. Failure occurring from inappropriate storage or handling, carelessness or negligence by the user. Failure caused by the user's hardware or software design.
  2. Failure caused by unapproved modifications, etc., to the product by the user.
  3. When the Mitsubishi product is assembled into a user's device, Failure that could have been avoided if functions or structures, judged as necessary in the legal safety measures the user's device is subject to or as necessary by industry standards, had been provided.
  4. Failure that could have been avoided if consumable parts (battery, backlight, fuse, etc.) designated in the instruction manual had been correctly serviced or replaced.
  5. Failure caused by external irresistible forces such as fires or abnormal voltages, and Failure caused by force majeure such as earthquakes, lightning, wind and water damage.
  6. Failure caused by reasons unpredictable by scientific technology standards at time of shipment from Mitsubishi.
  7. Any other failure found not to be the responsibility of Mitsubishi or that admitted not to be so by the user.

## 2. Onerous repair term after discontinuation of production

(1) Mitsubishi shall accept onerous product repairs for seven (7) years after production of the product is discontinued.

Discontinuation of production shall be notified with Mitsubishi Technical Bulletins, etc.

(2) Product supply (including repair parts) is not available after production is discontinued.

## 3. Overseas service

Overseas, repairs shall be accepted by Mitsubishi's local overseas FA Center. Note that the repair conditions at each FA Center may differ.

## 4. Exclusion of loss in opportunity and secondary loss from warranty liability

Regardless of the gratis warranty term, Mitsubishi shall not be liable for compensation of damages caused by any cause found not to be the responsibility of Mitsubishi, loss in opportunity, lost profits incurred to the user by Failures of Mitsubishi products, special damages and secondary damages whether foreseeable or not, compensation for accidents, and compensation for damages to products other than Mitsubishi products, replacement by the user, maintenance of on-site equipment, start-up test run and other tasks.

## 5. Changes in product specifications

The specifications given in the catalogs, manuals or technical documents are subject to change without prior notice.

## 6. Product application

(1) In using the Mitsubishi MELSEC programmable logic controller, the usage conditions shall be that the application will not lead to a major accident even if any problem or fault should occur in the programmable logic controller device, and that backup and fail-safe functions are systematically provided outside of the device for any problem or fault.

(2) The Mitsubishi programmable logic controller has been designed and manufactured for applications in general industries, etc. Thus, applications in which the public could be affected such as in nuclear power plants and other power plants operated by respective power companies, and applications in which a special quality assurance system is required, such as for Railway companies or Public service purposes shall be excluded from the programmable logic controller applications.

In addition, applications in which human life or property that could be greatly affected, such as in aircraft, medical applications, incineration and fuel devices, manned transportation, equipment for recreation and amusement, and safety devices, shall also be excluded from the programmable logic controller range of applications.

However, in certain cases, some applications may be possible, providing the user consults their local Mitsubishi representative outlining the special requirements of the project, and providing that all parties concerned agree to the special circumstances, solely at the users discretion.



# A950GOT/A951GOT/A953GOT/A956GOT

## User's Manual

MODEL	A950GOT-U(SHO)-E
MODEL CODE	1DM103
SH(NA)-080018-J(0611)MEE	



HEAD OFFICE : TOKYO BUILDING, 2-7-3 MARUNOUCHI, CHIYODA-KU, TOKYO 100-8310, JAPAN  
NAGOYA WORKS : 1-14, YADA-MINAMI 5-CHOME, HIGASHI-KU, NAGOYA, JAPAN

When exported from Japan, this manual does not require application to the Ministry of Economy, Trade and Industry for service transaction permission.

Specifications subject to change without notice.